



ROCKET *LINX* ES8508

ES8508 | ES8508F | ES8508-XT | ES8508F-XT

QUICK INSTALLATION GUIDE

2000577 Rev B | Release Date - September, 2013

INTRODUCTION

The RocketLinx ES8508 series features advanced Layer 2 management and security for deployment in mission critical networking applications.

The RocketLinx ES8508 series includes the following models:

- ES8508 with 8 Fast Ethernet ports
- ES8508F with 6 Fast Ethernet ports and 2 fiber ports (100BASE-FX Single-Mode and Multi-Mode models)
- ES8508-XT with 8 Fast Ethernet ports with an extended temperature range
- ES8508F-XT with 6 Fast Ethernet ports and 2 fiber ports (100BASE-FX Single-Mode and Multi-Mode models) with an extended temperature range

The different ES8508 models are simply referred to as the ES8508 unless there is model specific information.

See the Control website for complete product specifications.

INSTALLATION OVERVIEW

You can use the following overview to install the ES8508. If you need more detailed installation and configuration information, you can refer to the *RocketLinx ES8508 Series User Guide*, which is available on the RocketLinx CD or you can download the latest version.

Wiring the Power Inputs

The ES8508 provides redundant power, reverse polarity protection, and accepts a positive or negative power source but PW1 and PW2 must apply to the same mode. The recommended working voltage is 24VDC with an input range of 10-60VDC and a maximum power consumption of 15W.

1. Insert the positive and negative wires into PW+ and PW- contacts (PW1 and PW2). You can connect a single power supply or two power supplies depending on your requirements.
2. If both power inputs are connected, the ES8508 will be powered from the highest connected voltage. The unit can be configured to signal an alarm for loss of power in either PW1 or PW2.
3. Tighten the wire-clamp screws to prevent the wires from being loosened.

Power should be disconnected from the power supply before connecting it to the switch. Otherwise, your screwdriver blade can inadvertently short your terminal connections to the grounded enclosure.

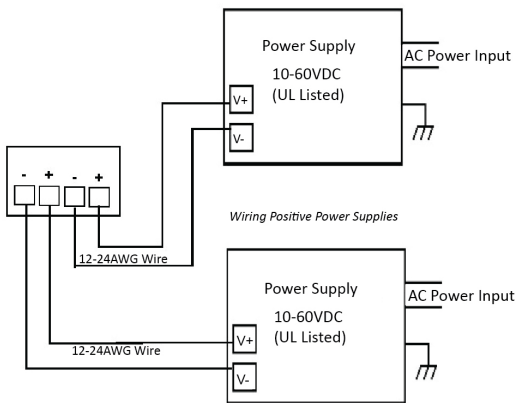

Wiring the Alarm Relay Output

The alarm relay output or digital output (DO) contacts are on the terminal block connector on the bottom of the ES8508.

The relay contact supports up to 1A at 24VDC. Do not apply voltage and current higher than the specifications.

The alarm relay output is controlled by the pre-defined operating rules. To activate the alarm relay output function, refer to the *RocketLinx ES8508 Series User Guide*.

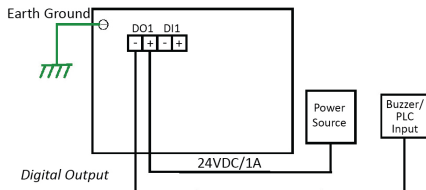

Wiring the Digital Input

The digital input (DI) contacts are on the terminal block connector on the bottom of the ES8508. The contacts accept one external DC type signal input and can be configured to send alert message through Ethernet when the signal is changed.

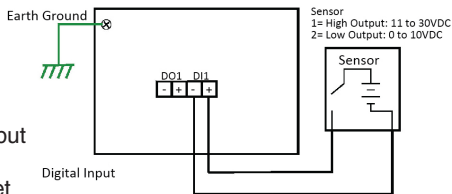

The DI supports isolated input circuit with digital high level input of 11VDC to 30VDC and digital low level input 0VDC to 10VDC. Do not apply a higher voltage than the specification; it may cause internal circuit damage or cause an incorrect DI action.

Grounding the ES8508

Wire the earth ground to ensure the system is not damaged by noise or any electrical shock, we recommend that you make a direct connection between the ES8508 and earth ground.

Using a screw driver, loosen the earth ground screw on the bottom of the ES8508 and then tighten the screw after the earth ground wire is connected.

Mounting the ES8508

The DIN rail clip is attached to the ES8508.

1. Insert the upper end of DIN rail clip into the back of DIN rail track from its upper side.
2. Lightly push the bottom of DIN rail clip into the track.
3. Verify that the DIN rail clip is tightly attached on the track.

Connecting RJ45 Ports

Connect one end of an Ethernet cable into the Ethernet port of the ES8508 and the other end to the attached networking device. The RJ45 ports support 10/100Mbps half/full-duplex. All RJ45 ports auto-detect the signal

from connected devices to negotiate the link speed and duplex mode. Auto MDI/MDIX allows users to connect another switch, hub, or workstation without changing straight through or crossover cable.

10/100BASE-TX Cabling

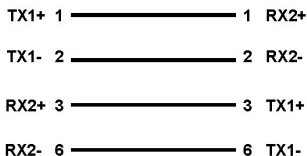

Straight-Through Cabling

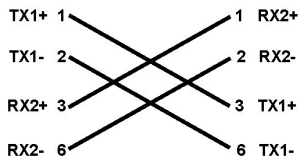

Crossover Cabling

Link/Act LEDs are lit to indicate traffic and link status, see the LEDs subsection for more information.

Always make sure that the cables between the switches and attached devices (for example, switch, hub, or workstation) are less than 100 meters (328 feet). You should use 10/100BASE-TX: Category 5 Cable or higher.

Connecting Fiber Ports (ES8508F/ES8508F-XT Models Only)

Connect the fiber port to another Fiber Ethernet device using the following diagram. An improper connection will cause the fiber port to not work properly. The fiber port is a standard or square connector (SC). Make sure that the fiber mode of the cable matches the fiber mode of the ES8508 (Single-Mode or Multi-Mode).

ATTENTION



This is a Class 1 Laser/LED product.
Do not stare into the Laser/LED Beam.

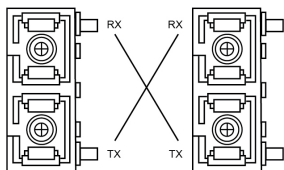

A B
Cable Wiring(SC to SC)

TX A ————— RX B
RX A ————— TX B

See the *ES8508 Series User Guide* if you need fiber cabling specifications.

PROGRAMMING THE IP ADDRESS

Configure the IP address using one of the following methods:

- PortVision DX (available on the RocketLinX CD shipped with the product)
- Web browser
- Telnet
- Command line interface (CLI) using the RS-232 console cable

The easiest way to configure a static IP address for your network in the ES8508 is to use a Windows host and PortVision DX (see below). For information about using other configuration methods, refer to the *RocketLinX ES8508 Series User Guide*.

Note: *Optionally, you can use NetVision if you are accustomed to using NetVision. PortVision DX is replacing NetVision. NetVision is not documented in the RocketLinX ES8508 Series User Guide.*

The following procedure uses PortVision DX to program network settings.

1. Install PortVision DX on a host system with a Windows operating system. If you need assistance installing PortVision DX, see the *RocketLinX ES8508 Series User Guide*.
2. Start PortVision DX. PortVision DX can be started from **Start --> All Programs --> Control --> PortVision DX**.
3. Click the **Scan** button.
4. Select the Control product families that you want to locate and click the **Scan** button.
5. Right-click the ES8508 in the Device List pane (lower) that you want to configure and click **Properties**.
6. Enter a user-friendly Device Name.
7. Optionally, enter the ES8508 serial number, which displays a friendly device name in the *Device List* pane on the main page.
8. Select **DHCP IP** or **Static IP** for the *IP Mode*.
 - If you select **DHCP IP**, go to Step 9.
 - If you select **Static IP**, enter an IP address, Subnet Mask, and Default Gateway value for your network.

9. Optionally, select the appropriate **Network Topology**, which is an informational field.
10. Click the **Apply Changes** button.
11. Click **Close** to return to the main screen.
12. You are now ready to configure the ES8508 features.

LED INDICATORS

You can also view the LEDs for the ES8508 through the web interface using the *Device Front Panel* page.

LED Name	LED On	LED Blinking	LED Off
SYS	Green: System ready	Green: Firmware loading	Power off
PWR1/2	Green: System power ready	Not applicable	System not ready
R.S. (Ring Status)	Green: Ring is normal Amber: Abnormal ring	Green: Ring with the wrong port Amber: The device's ring port failed	Switch working in slave mode
DO1	Relay is active and contacts have been shorted	Not applicable	DO not activated
DI1	High digital signal is detected	Not applicable	DI not activated
LNK/ACT	Port is linked	Port active	Port link down or port not connected

FEATURE CONFIGURATION

The ES8508 provides both in-band and out-band configuration methods:

Out-band management means that you configure the ES8508 using the RS-232 console cable and the Command Line Interface (CLI) to access the ES8508 without attaching an admin PC to the network. You can also use out-bound management, if you lost the network connection to the ES8508.

In-band management means that you connect remotely using the ES8508 IP address through the network. You can remotely connect with the ES8508 Java applet web interface or a Telnet console and the CLI.

The following procedure uses a web browser to configure ES8508 features. Refer to the *RocketLinx ES8508 Series User Guide* for other configuration methods.

1. If necessary, install the latest version of the Java Runtime Environment, which is required to run the web management interface.
2. Open a web browser and enter the IP address of the ES8508.
3. Click **Run** when Java prompts you to run the applet.
4. Enter **admin** for both the user name and the password when prompted.
5. Use the web interface to configure your device as needed for your network.

You can use the help system or the *RocketLinx ES8508 Series User Guide* for information about configuring RocketLinx ES8508 features.

CONTROL CUSTOMER SERVICE

You can use one of the following methods to contact Control.

Contact Method	Web Address or Phone Number
Support	http://www.comtrol.com/support
Downloads	ftp://ftp.comtrol.com/html/ES8508_main.htm
Website	http://www.comtrol.com
Phone	+1 763.957.6000

