



RocketLinx ES7105

Industrial Ethernet Switch

User Guide

Trademark Notices

Control is a trademark of Control Corporation.

Other product names mentioned herein may be trademarks and/or registered trademarks of their respective owners.

Third Edition, June 12, 2012

Copyright © 2010 - 2012. Control Corporation.

All Rights Reserved.

Control Corporation makes no representations or warranties with regard to the contents of this document or to the suitability of the Control product for any particular purpose.

Contact your reseller for current product information.

Table of Contents

Trademark Notices	2
Chapter 1 Introduction	5
Overview.....	5
Ethernet Switching Technology.....	5
Product Features	8
Package Checklist	8
Chapter 2 Hardware Installation	9
Introduction	9
Wiring the Earth Ground	12
Wiring the Power Inputs.....	12
Wiring the Relay Output.....	12
Wiring the Ethernet Ports	13
Connecting to PD.....	14
DIN-Rail Mounting Installation.....	15
Chapter 3 Troubleshooting	17
Power Connections.....	17
Incorrect Connections	17
LED Indicators	18
Customer Support.....	19

1

Introduction

The RocketLinx ES7105 is a power over Ethernet switch that is specially designed for industrial or commercial applications.

The following topics are covered in this section:

- **Overview**
- **Ethernet Switching Technology**
- **Power over Ethernet Technology**
- **Product Features**
- **Package Checklist**
- **Installation Guide**

Overview

The RocketLinx ES7105 Industrial Power Over Ethernet (PoE) switch provides four ports 10/100 TX PoE and one 10/100TX uplink port. The ES7105 is designed to operate under harsh environmental conditions. The switch provides Power over Ethernet functions to deliver 15.4 W power to powered device (PD), which is in compliance with IEEE802.3af standard to deliver both of Ethernet data and DC 48V power through the traditional Ethernet cable to the PD.

The IP30-design aluminum case further strengthens the RocketLinx ES7105's ability to withstand harsh industrial environments. Event warnings are notified to field engineers by relay output, which triggers field alert systems. The RocketLinx ES7105 has passed CE/ FCC/ UL safety certifications to help ensure safe and reliable data transmission for industrial applications.

Ethernet Switching Technology

To better understand the operation of an Ethernet switch, we need to first differentiate it from a hub. An Ethernet hub (or repeater) is a device that is used to simply connect Ethernet nodes. Any message at one hub port is repeated on all ports. That is, hubs forward data packets they receive from a single station to all hub ports. As a result, all port devices connected to a single hub will share the same bandwidth. Then as nodes are added to the network hub, they compete for this finite amount of bandwidth and this can cause data collisions to occur, making network determinism impossible to attain, especially on busy networks. Now determinism is a term that is used to describe the ability to guarantee that a packet is sent or received in a finite and predictable amount of time. The inherent lack of determinism is the main reason that traditional Ethernet had problems being accepted for use in critical control applications, as most control systems have a defined time requirement for packet transmission, typically less than 100ms.

RocketLinx ES7105 Industrial Ethernet Switch User Guide

Switches on the other hand, are intelligent devices used to more efficiently connect distributed Ethernet nodes than a hub. Unlike a simple hub, a switch provides *targeted* data transfer, as it will forward a data packet to a specific port or network segment, rather than to all ports, thus freeing up bandwidth. The ability to target a packet to a specific port increases network throughput and helps to eliminate the collisions that have historically made Ethernet non-deterministic.

So we see that by targeting the data transfer between ports, switches act as intelligent repeaters to increase network distances. In doing this, they actually split networks into separate collision domains at each port. Thus, switches increase determinism by reducing collisions. Switches also increase network bandwidth and throughput, as well as provide supplemental error checking on data packets to help ensure the integrity of forwarded data. Each port of this switch functions just like any other Ethernet device. It is able to receive and decode Ethernet frames, test for frame integrity, plus assemble and transmit Ethernet frames.

With Ethernet, any device can try to send a data frame out at any time. If two devices happen to send a data frame at the same time, then a collision may occur. The arbitration protocol for carrier transmission access of the Ethernet network is called Carrier Sense Multiple Access with Collision Detect (CSMA/CD). With CSMA/CD, each device will first sense whether the line is idle and available for use. If it is, the device will begin to transmit its first frame. If another device also tries to send a frame at the same time, then a collision occurs and both frames are discarded. Each device then waits a random amount of time and retries its transmission until it is successfully sent.

Unlike other Ethernet devices, such as an Ethernet host adapter or Network Interface Card (NIC), the port of a switch does not require its own MAC address. During retransmission of a received packet, the switch port will instead look like the originating device by having assumed its source address. This is why the Ethernet collision domain is said to terminate at the switch port. That is, a two-port switch will effectively break a network into two distinct data links or segments. The RocketLinx ES7105 Industrial Ethernet switch can break a network into 5 distinct data links or segments (also called *collision domains*). Since all Ethernet nodes are able to recognize the occurrence of a collision, and since the detection of a collision is principal to the way Ethernet arbitrates media access, large domains containing many nodes can become quite cumbersome. Thus, using an Ethernet switch to subdivide a large network into separate collision domains will certainly help to increase throughput.

The current tendency in critical industrial control applications is to connect one Ethernet device per switch port. This will produce the most deterministic mode of operation as the switch can then operate full-duplex, with no chance of collisions. This ensures determinism, helping critical control applications to remain predictable and on-time.

Each port of a switch forwards data to another port based on the MAC address contained in the received data packet/frame. In order to know which port to forward a data packet to, the switch will learn and store the MAC addresses of every device it is connected to, along with the associated port number. However, until the switch actually learns the port a particular address resides at (the first packet), it forwards this traffic to all ports just like a hub. The switch will use its internal look-up table to quickly determine the location (port) of a node, establish a temporary connection between itself and the node, then terminate the connection once a packet is transferred. In this way, it increases network bandwidth and provides the network determinism required for critical control applications.

RocketLinx ES7105 Industrial Power over Ethernet (PoE) switch uses a *store and forward* algorithm to process Ethernet frames. That is, it first stores the Ethernet frame and examines it for errors before forwarding it to its destination. Although this method may seem to increase the forwarding time (latency) and possibly cause fragmentation, it effectively reduces the occurrence of error frames and improves overall throughput. This is particularly useful when there is heavy network traffic and or greater potential for noise and interference.

The industry-wide shift from Ethernet hubs to Ethernet switches has dramatically boosted the bandwidth of networks and helped to eliminate congestion problems inherent with the CSMA/CD protocol (Carrier Sense Multiple Access with Collision Detection). Since a switch operates by learning the location of addresses and forwarding messages directly, unnecessary traffic is greatly reduced. It will use auto-negotiation to regulate the speed and duplex of each port based on the capabilities of connected devices. These features combine with flow control allow a 100M node to effectively communicate with a 10M node without losing data. Connecting one device per switch port also allows two-way, simultaneous transmission to occur (full duplex), essentially doubling the bandwidth. Further, by segmenting a collision domain in this way, the need for non-deterministic carrier sensing (CSMA/CD) is eliminated. The utilization of a store-and-forward switching algorithm allows each packet to be inspected, and corrupt or redundant data to be filtered, further eliminating unnecessary traffic that often slows a network down.

Power over Ethernet Technology

Power over Ethernet is a revolutionary technology that allows IP telephones, wireless LAN Access Points, Security network Cameras and other IP-based terminals to receive power and data in parallel. The Power over Ethernet can bring a lot of benefits, such as cost saving, simplicity, reliability, safety, control and security.

The IEEE802.3af (Power over Ethernet) is established on June 2003, which defined how to deliver DC 48V power and Ethernet frame through the traditional cabling system.

PoE architecture includes 2 elements, Power Sourcing Equipment (PSE) and Powered Device (PD), PSE device provides auto detection capability to recognize the characteristics of link partner to deliver exactly power to the PD, it also will not damage the link partner if it is not a PD or the link cable is short, or the device is broken, and execute a series of standard procedure when the PD is disconnected to avoid send out a huge power to damage the device or user.

The IEEE802.3af standards have specified the architecture and the type of PSE, PSE supports 2 different types, End-point and Mid-Span for the different power feeding model and wiring.

In the IEEE803.3af also specified the PD should compatible with End-point and Mid-Span PSE, and exactly, honestly claims the level of power consumption.

The RocketLinx ES7105 equips four PoE ports, with each port delivering power up to 15.4 watts maximum, and one 10/100Base TX uplink port for transferring data. The RocketLinx ES7105 conforms to IEEE 802.3af Power over Ethernet (PoE) standard. Using an external 48VDC power supply, the RocketLinx ES7105 enables power and data transmission to be pumped out over the same Ethernet cable in the four PoE ports.

The RocketLinx ES7105 is in compliance with IEEE 802.3af standard and supports Power Sourcing Equipment (PSE) function. It delivers power through the spare pairs (4, 5, 7, 8) of standard Ethernet CAT_5 cable and transmits data through the traditional pairs (1, 2, 3, 6). The RocketLinx ES7105 PoE ports provide PoE auto detection of the link partner to deliver the exact power to the PD. If the link partner is not a PD or the link cable is short, or the device is broken, it will executes a series of standard procedures to avoid sending out a huge power to damage the linked device.

Product Features

The RocketLinx ES7105 has the following features:

- 4-port 10/100TX with PoE injector plus one 100Mbps uplink port
- Delivers 15.4W power budget per PoE port
- Redundant DC Power Inputs
- Alarm Relay to signal port break and/or power failure
- Support IEEE 802.3 10Base-T, 802.3u 100Base-TX
- 512K bits embedded memory buffer with 1K entry MAC address table
- auto MDI/MDI-X RJ45 ports
- Store-and-Forward switching architecture
- IEEE 802.3x flow control
 - Flow control on full-duplex mode
 - Back pressure on half-duplex mode
- Reverse power polarity protection
- Robust Aluminum case, IP30 standard
- DIN-Rail/Wall-mounting/Desktop Installation

Package Checklist

The RocketLinx ES7105 is shipped with the following items:

- One industrial PoE switch
- One DIN-Rail kit
- Documentation CD
- *RocketLinx ES7105 Quick Installation Guide (QIG)*

If any of the above items are missing or damaged, please contact your local sales representative.

2

Hardware Installation

This chapter includes information of installation and configuration. The following topics are covered in this chapter:

- **Introduction**
 - Dimension
 - Panel Layout
 - LED Indicators
 - DIP Switch
- **Wiring the Power Inputs**
- **Wiring the Relay Output**
- **Wiring the Ethernet Ports**
- **DIN-Rail Mounting Installation**
- **Wall-Mounting Installation**

Introduction

RocketLinx ES7105 Dimensions

Following is the RocketLinx ES7105 mechanical dimension diagram, the unit is mm.

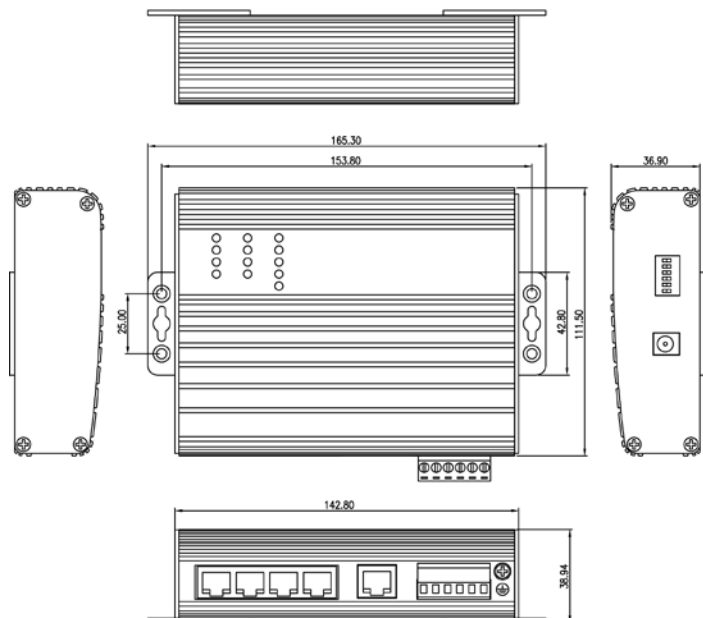

Panel Layout

The following figure includes product view of top side, right side and front side for the RocketLinx ES7105.

Top View

On the top side includes diagnostics LEDs for system Power, Fault LED, PoE power forwarding status and port link status. On the right side include DIP Switch, external DC jack for AC/DC power adapter power input.

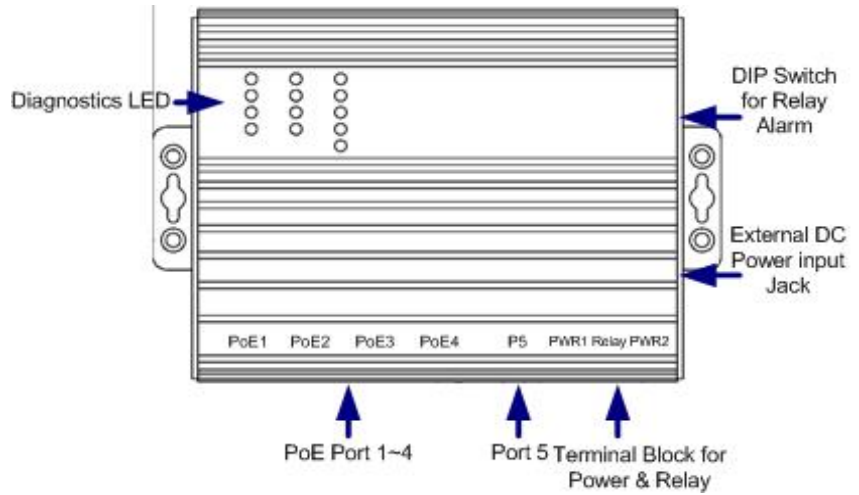

Right Side View

The DC jack accepts DC 48V without reverse polarity protection. The DIP switch is for the event relay control for port link and power event. Easy configuration, just ON/OFF, to enable or disable each event trigger.

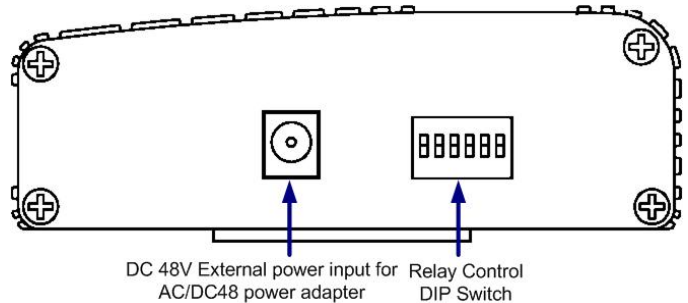

Front Side View

It includes four IEEE802.3af PoE switch ports and one RJ45 for uplink.

The 6-pin terminal block connector is for DC 48V power input and relay alarm output. It is equipped with two power inputs with reverse polarity protection and the input power range from DC 44V to DC 57V.

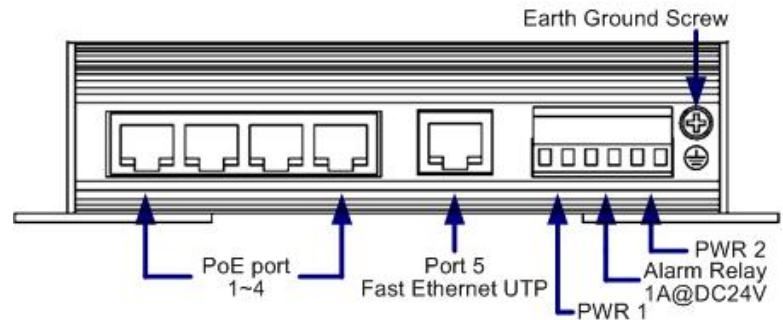

The Relay Alarm Output is triggered by the port or power event and disable/enable with the DIP switch.

If any event occurs, the relay output is formed as a close circuit. The ability of relay is DC24V/1A.

To ensure the system working in a reliable status, make sure it has been grounded with the Earth Ground Screw and System Earth Ground before powering on the RocketLinx ES7105.

LED Indicators

There are 13 diagnostic LEDs on the RocketLinx ES7105 switch. These LED indicators provide administrators with real-time system status. The following table describes the function of each LED indicator.

LED	Status	Description
PWR	Green	DC-IN Power Jack is On
	Off	No Power in DC-IN
PWR 1	Green	Terminal Block PWR1 Power is on.
	Off	No power in Terminal Block PWR1
PWR 2	Green	Terminal Block PWR2 Power is on.
	Off	No power in Terminal Block PWR2
Fault	Red	Port link down or power link down For the Power status, it only supports for the Power 1 and Power 2.
PoE LED	Status	Description
PoE 1~4	Green	The port is delivering PoE power.
	Off	No PD is attached
Port LED	Status	Description
P1~5 LNK/ACT	Yellow	A network device is detected.
	Blinks	This port is transmitting to, or receiving packets from another transmitting device.
	Off	No device is attached.

DIP Switch

The DIP switches are used to configure the power alarm and to separately enable the port alarms.

DIP SWITCH	Status	Description
DIP 1~5	ON	To enable the port alarm function. Once the port links down, the switch will trigger the relay alarm output circuit to enable the external alert system. The DIP switch 1~5 is mapping to the Port 1~5.
	Off	Disable the port alarm function.
DIP 6	ON	To enable Power fault alarm function.
	Off	To disable Power fault alarm function.

Notes (DIP Switches):

1. If the corresponding port alarm DIP switch is set ON, when that port connection fails, the Fault LED will light up and the alarm relay contacts will close.
2. After setting any DIP Switch, you will need to reboot power to activate the setting.

Wiring the Earth Ground

Connect the frame grounding of switch to the grounding surface to ensure safety and prevent noise.

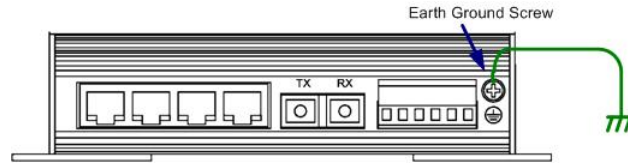

Wiring the Power Inputs

IMPORTANT: It is a good practice to turn off power input and unplug the power terminal block before making wire connections. Otherwise, your screwdriver blade can inadvertently short your terminal connections to the grounded enclosure.

1. Insert the positive and negative wires of your DC supply into the V+ and V- contacts of the terminal block connector. The acceptable wire range is 12 to 24 AWG.

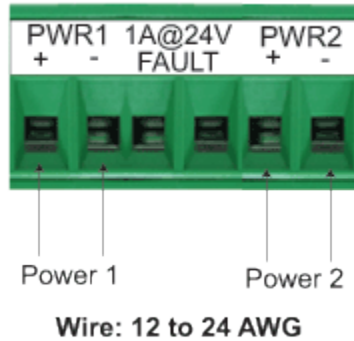

2. Tighten the terminal screws to prevent the DC wires from coming loose.



3. **OPTIONAL – DC IN:** The RocketLinx ES7105 has an additional power jack for the connection of AC-DC power converters (wall-transformer type) designed for office use. Be sure that the output voltage is at 48V DC to power the unit. Refer to switch PWR LED to verify the power via the DC-IN jack.

Note: If all three power inputs are connected (DC IN, PWR 1, PWR 2), the RocketLinx ES7105 will be powered from the highest connected voltage. The unit will not alarm for loss of DC IN power, the alarm function only applies to loss of power at PWR1 or PWR2.

Wiring the Relay Output

The alarm output relay contacts are located at the two middle terminals of the power terminal block, between PWR2 and PWR1 as shown in the figure below. These contacts are single-pole single-throw (SPST) and are energized (open-circuited) for normal operation. These contacts will close if the unit is not powered, or if either DC power 1 or power 2 fails, or if a port connection fails (if that port alarm DIP switch is ON). The figure below gives an example of how the output alarm relay operates.

Note: The relay contacts are energized (open) for normal operation and will close for fault conditions.

RocketLinx ES7105 Industrial Ethernet Switch User Guide

This contact does not supply any power and is rated up to 24V DC at 1A current.

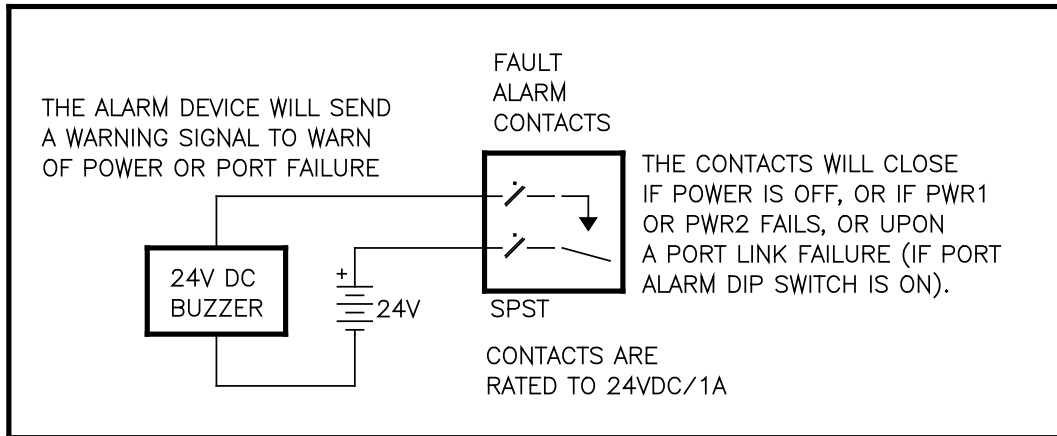

1. Connect to the SPST alarm relay terminals as per your application. Insert your load wires and tighten the alarm terminal screws to prevent the wires from coming loose. These contacts are open for normal operation and close in alarm. Do not exceed 24V and 1A current.

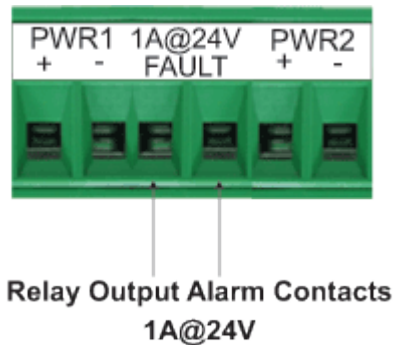

2. Verify that your load is wired to the central two terminals of this terminal block. After the relay is wired, insert this terminal block into its socket.

Wiring the Ethernet Ports

The RocketLinx ES7105 supports four RJ45 ports with automatic MDI/MDI-X crossover, PoE Injector, and automatic 10/100Mbps data rate sensing for 10Base-T or 100Base-TX connections. Automatic MDI/MDI-X crossover allows you to connect to other switches, hubs, or workstations, without regard to using straight-through or crossover cabling.

The switch also provides one RJ45 uplink. Port 1 to Port 4 also provides Power over Ethernet function that delivers DC 48V power through the spare pairs to power the PD.

The DC +48V is delivered through the RJ45 pin 4 and 5, DC-48V through the RJ45 pin 7 and 8.

The following figures depict the schematic diagram of straight-through and crossover cabling. Note that crossover cables simply cross-connect the transmit lines at each end to the receive lines at the opposite end.

RocketLinx ES7105 Industrial Ethernet Switch User Guide

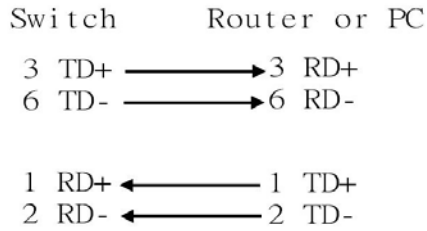

Straight-through Cabling Schematic

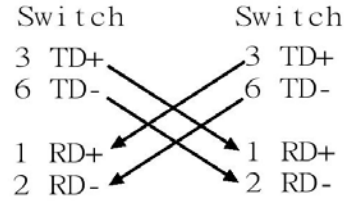

Cross-over Cabling Schematic

Note: that Ethernet cables use Pins 1, 2, 3, and 6 of an 8-pin RJ45 connector. The signals of these pins are converted by the automatic MDI-X function, as shown in the table below:

Pin MDI-X	Signals	MDI Signals
1	RD+	TD+
2	RD-	TD-
3	TD+	RD+
6	TD-	RD-

Connect one side of an Ethernet cable into any switch port and connect the other side to your attached device. The green LNK LED will light up when the cable is correctly connected. Refer to the **LED Indicators** section for descriptions of each LED indicator. Always make sure that the cables between the switches and attached devices (e.g. switch, hub, or workstation) are less than 100 meters (328 feet).

Connecting to PD

Port 1 to Port 4 provide PoE injection function with a maximum of 15.4W to power up the powered device using a straight or cross-over Ethernet cable.

The RocketLinx ES7105 follows the IEEE802.3af Alternative B mode connector assignment. The following table shows pin assignment of alternative A and B for the PSE (Power Source Equipment).

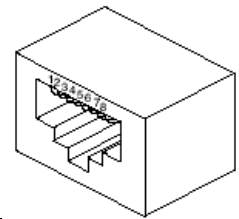

Conductor	Alternative A (MDI-X)	Alternative A (MDI)	Alternative B (All)
1	Rx & Negative Vport	Tx & Positive Vport	
2	Rx & Negative Vport	Tx & Positive Vport	
3	Tx & Positive Vport	Rx & Negative port	
4			Positive Vport
5			Positive Vport
6	Tx & Positive Vport	Rx & Negativen Vport	
7			Negative Vport
8			Negative Vport

Pin assignment of PSE

RocketLinx ES7105 Industrial Ethernet Switch User Guide

Be sure the twisted pair cable is bound with the standard RJ45 pin, especially Pins 4, 5, 7 and 8.

If the RJ45 is bound with the wrong pin number, the ES7105 will not recognize the PD and won't forward DC 48V power to PD, since the ES7105 switch follows the Alternative B mode.

In the IEEE 802.3af standard documents, it indicates the PD should support mode A and B, and only receiver power from either mode A or mode B.

The following table shows the RJ45 pin out for the PD.

PD Pinout		
Conductor	Mode A	Mode B
1	Positive Vport, Negative Vport	
2	Positive Vport, Negative Vport	
3	Negative Vport, Positive Vport	
4		Positive Vport, Negative Vport
5		Positive Vport, Negative Vport
6	Negative Vport, Positive Vport	
7		Negative Vport, Positive Vport
8		Negative Vport, Positive Vport

DIN-Rail Mounting Installation

Wall mount: Use the screws provided in the mounting kit and mount on the wall.

Din Rail Mount: Use the screws provided in the mounting kit to screw up the clip on the right and left mount ears.

Use a cross screw driver to screw up the DIN rail clip, the DIN rail clip should be screwed in the rear of the ear, and then clipped on the DIN rail.

3

Troubleshooting

This chapter includes the information for general troubleshooting. The following topics are covered in this section:

- **Power Connections**
- **Incorrect Connections**
 - Faulty or Loose Cables
 - Non-standard Cables
 - Improper Network Design
- **LED Indicators**

Power Connections

The RocketLinx ES7105 is powered by 48V DC. You should verify that the output of your DC supply voltage, or AC-DC power adapter, is at 48V DC while under load.

IMPORTANT: The power input range for the RocketLinx ES7105 is from 44v to 57v, but to avoid damage and keep the switch with good performance, we strongly suggest you choose DC 48V as the power input.

If you are using an AC-DC power adapter and the DC-IN power indicator (PWR) of the RocketLinx ES7105 does not light when the power cord is plugged in, you may have a faulty power cord. Check for loose or broken power connections. Also check for power loss or power surges at the AC power outlet. Verify that your AC-DC adapter is properly sized and outputs the correct voltage under load.

Incorrect Connections

Select Ethernet cables with specifications suitable for your application. In general, Ethernet cables are categorized into unshielded twisted-pair (UTP) and shielded twisted-pair (STP) types. Shielded cables are recommended. In general, Category 3, 4, and 5 Ethernet cables are suitable for systems with 10Mbps transmission speed. But for systems at 100Mbps, you should only use Category 5 or better Ethernet cables. In addition, always make sure that the cable length between device ports does not exceed 100 meters (328 feet).

The RJ45 ports of this switch automatically detect straight-through or crossover cables and then cross-connect the transmit and receive channels when you connect the switch to another device.

For the RJ45 connectors, use the correct UTP or STP cables as required. For 10/100M ports, use 2 pairs of twisted cables.

Faulty or Loosen Cables

Visually inspect for loose or obviously faulty connections at all connectors and cables. If that does not correct the problem, try replacing the cable.

Non-standard Cables

Non-standard and incorrectly-wired cables may generate increased network collisions and other network problems which will impair network performance. A category 5 cable tester is a recommended tool for every 100Base-TX network installation.

Improper Network Design

Verify that your network has been properly designed. Most errors simply result from poor quality cable, poor cable routing, network congestion, improper cable length, and too many repeater/hubs between end nodes. Errors may also result from inadvertent data path loops (redundant message paths). Message loops can generate broadcast storms that can bog down a network. There should be only one active message path between any two nodes on a network.

Excessive collisions may be indicative of a cable that is too long. It may also signal the presence of too many repeaters (hubs) between devices and can also be indicative of a congested network (too many nodes in one segment).

A high number of undersized and fragmented packets can result from interference induced into the network cable, by either passing it too close to noisy devices, or because of problems with the network devices themselves. In these instances, check for improper cabling, damaged cables, or cables routed too closely to noisy equipment or other wiring.

A high number of oversized packets can result from a bad transceiver, excessive cable noise, or from a speed mismatch between the switch ports and the connected devices.

LED Indicators

The RocketLinx ES7105 can also be visually monitored via its own front-panel LED indicators. This can be useful to assist in identifying common problems and to help you find possible solutions.

Check the redundant PWR1 and PWR2 LED's to verify DC power. The PWR LED will light for any connected power (PWR1, PWR2, or DC-IN).

Check PWR for power via an AC adapter connected to DC-IN. If the power LED indicator does not light when the power cord is plugged in, you might have a problem with the power outlet, or the power cord. If the switch simply powers OFF on its own after running for a period of time, check for loose power connections, power losses, or surges at the power outlet. You should also verify that your supply voltage remains within the required DC 48V while under load.

Refer to the port Link LED (LNK) to verify that a connection has been properly established (solid green). A blinking green LNK LED indicates communication activity. If the LNK LED remains off after making a connection, then no device has been detected and the cable may be bad or the connected device may be un-powered.

Refer to the PoE LED (Green) to monitor for delivering power. A green on PoE LED indicates that DC 48V is on feeding to the PD from the RocketLinx ES7105. This LED will be solid ON during on the power feeding. If the PD request power exceeds the 12.95 Watts or the cable loose, short, the LED will turn off and stop feeding power to the PD. To avoid those wrong situations, be sure the PD power consumption is below 12.95 Watts and the cable is without any failure before installing the PD.

Customer Support

Method	Contact Information
Support	http://www.comtrol.com/pub/en/Support
Downloads	ftp://ftp.comtrol.com/html/default.htm
Forum	http://forum.comtrol.com
Phone	763.957.6000