



ROCKET*LINX* ACS7106

Industrial PoE Plus Switch

QUICK INSTALLATION GUIDE

2000572 Rev A | Release Date - April, 2013

INTRODUCTION

The RocketLinx ACS7106 is an industrial UL294 listed Power over Ethernet Plus (PoE+) switch with voltage boost technology. The ACS7106 provides power and Ethernet communications to PoE devices. The ACS7106 features four Fast Ethernet PoE Plus ports and two Gigabit uplink ports to ensure a high-bandwidth connection. The ACS7106 is compliant with the IEEE 802.3af/802.3at PoE standards to deliver a maximum of 30W per port. The total PoE power budget for the ACS 7106 in UL294 installations is 90W and 100W in non-UL294 applications.

Using the alarm output relay, the ACS7106 can automatically warn the administrator if there are port or power failures on the PoE ports and port failures on the Gigabit ports. The ACS7106 is suitable in harsh environments because it meets the requirements of the stringent UL294 requirements and reliably operates in -40 to 55°C environments.

RocketLinx ACS7106 Installation Diagram

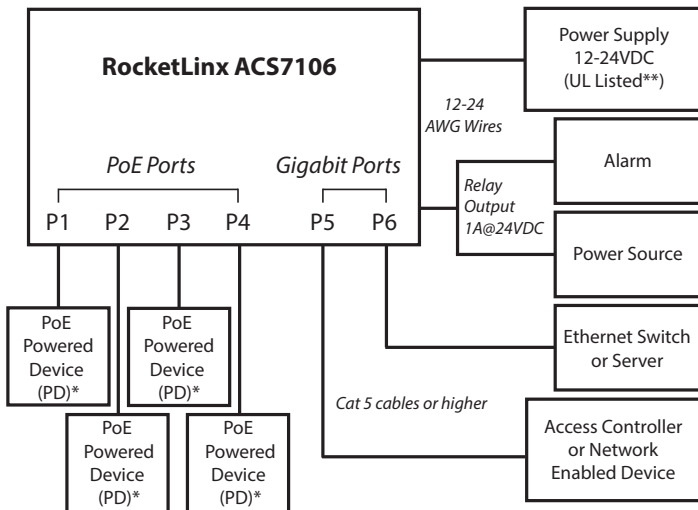

***PD** For example: PoE (IEEE 802.3af/802.3at compliant card readers, remote access panels, or cameras

****** For UL294 installations, the power supply must be regulated and UL294 compliant

802.3af Cat 5 or higher cable
802.3at Cat 5e or higher cable

See Control's website for detailed product specifications.

TECHNICAL SPECIFICATIONS

Electrical Specifications		Value
Number of Ports		<ul style="list-style-type: none">• Four 10/100BASE-TX PoE• Two 10/100/1000BASE-TX
Power Input		12-24VDC
Power Consumption (Without PD Loading)		<ul style="list-style-type: none">• 700mA @ 12VDC• 350mA @24VDC
Power Consumption (With PD Loading)		<ul style="list-style-type: none">• 6.8A @ 12VDC• 4.8A @ 24VDC• 4.5A @ 24VDC (UL294)
Max, Output/Power PoE Port		30W
Standard PoE Voltage Output	@ACS7106 output ports	52-54.3VDC
	100m* Cat5e @30W (24AWG)	47-49VDC
	100m* Cat5e @30W (26AWG)	44.5-46VDC
<i>* At the end of the specified distance</i>		

Note: Exceeding the recommended power and operating temperatures may result in failures or damage.

Electrical Specifications		Value
Total PoE Power Budget	UL294 installation (VIN = 24VDC)	90W
	UL294 installation (VIN = 12VDC)	60W
	Non-UL294 installation (VIN = 24VDC)	<ul style="list-style-type: none"> • 100W @ operating temperature -40° - 50°C • 90W @ operating temperature 50° - 55°C
	Non-UL294 installation (VIN = 12VDC)	60W @ operating temperature -40° - 55°C
Operating Temperature		<ul style="list-style-type: none"> • -40° - 55°C • 0° - 49°C (UL294)
Storage Temperature		-40° - 85°C
Operating Humidity		0 - 95%

The product is UL listed for an operating temperature range of -40° to 55°C. Comtrol has qualified and tested the product to operate at temperatures up to 60°C. At 60°C, the product can provide a maximum PoE output of 90W with an input voltage of 24VDC and 60W with an input voltage of 12VDC. For installation requiring UL60950 listing, the product should only be operated between -40° and 55°C. If the product is operated at 60°C, caution must be taken to not touch the hot surface of the product enclosure.

MOUNTING THE ACS7106

Make sure that you use appropriate screws when securing the ACS7106.

In UL294 installations, #8 self-tapping screws can be used to mount the ACS7106. Use one or two screws on each side to mount the ACS7106.

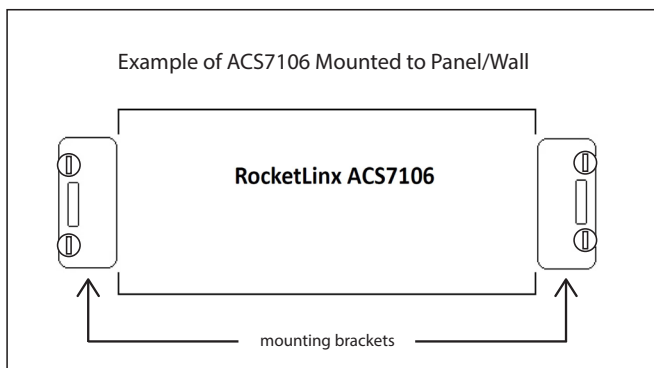

GROUNDING THE ACS7106

The ACS7106 must be tied to earth ground to ensure the system meets EMC/EMI requirements.

Using a screw driver, loosen the earth ground screw on the side of the ACS7106 and then tighten the screw after the earth ground wire (12-14AWG) is connected.

SETTING THE DIP SWITCHES

The ACS7106 has a 6-pin DIP switch located on the side panel to configure the alarm relay output. This table shows the DIP switch mapping to the corresponding PoE and Gigabit ports.

DIP Switch	Setting	Description
PoE Ports 1-4 (DIPs 1-4)	On	Enables the alarm for the corresponding PoE port
	Off (Default)	Disables the alarm for the corresponding PoE port
Gigabit Ports 5-6 (DIPs 5-6)	On	Enables the alarm for the corresponding Gigabit port
	Off (Default)	Disables the alarm for the corresponding Gigabit port

NOTE: If a port is not connected, make sure that the corresponding DIP switch remains in the OFF position so that the alarm is not activated.

WIRING THE POWER INPUTS

The power supply input range is 12-24VDC with a maximum power consumption of 8W without PoE PD loading.

Wiring methods shall be compliant with National Electrical Code/NFPA 70/ANSI.

NOTE: Power should be disconnected from the power supply before connecting it to the switch. Otherwise, your screwdriver blade can inadvertently short your terminal connections to the grounded enclosure.

1. Disconnect the power terminal block from the ACS7106.
2. Insert the positive and negative wires into PWR+ and PWR- contacts.
3. Tighten the wire-clamp screws to prevent the wires from being loosened.

NOTES:

- For UL installations, the ACS7106 is intended to be used with a regulated UL Listed Class 2 or LPS (Limited Power Supply).
- For the highest specified PoE output load, the ACS 7106 is intended to be used with a regulated UL Listed Class 2 or LPS rated at:
 - 24VDC @ 4.8A or 12VDC @ 6.8A, minimum. (UL60950 Installation)
 - 24VDC @ 4.5A or 12VDC @ 6.8A, minimum. (UL294 Installation)

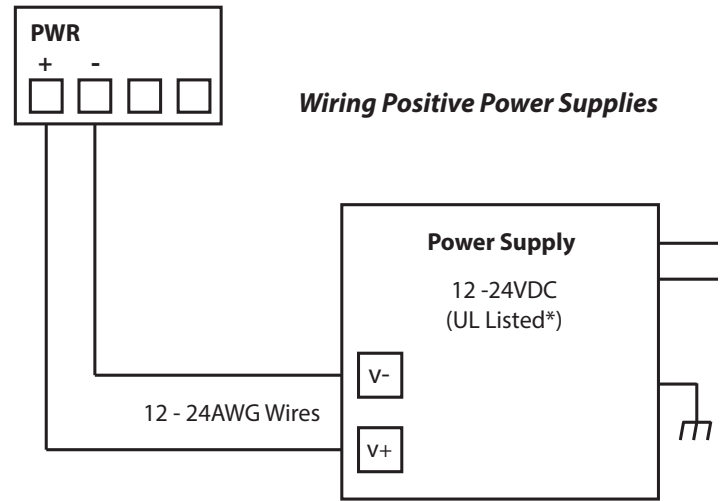

***UL 294:** A regulated UL294 approved power supply is required to meet UL294 installation requirements.

WIRING THE ALARM RELAY OUTPUT

The alarm relay output or digital output (DO) contacts are on the terminal block connector. The alarm relay output contacts are normally open. The alarm relay output contacts close when the alarm is enabled with the DIP switches and there is a port link failure or PoE failure on a port.

NOTE: The alarm relay is not intended to be an indication of a burglary alarm condition.

The alarm relay output contacts support up to 1A at 24VDC. Do not apply voltage and current higher than the specifications.

The alarm relay output is controlled by the pre-defined operating rules. To activate the alarm relay output function, refer to the *Setting the DIP Switches* discussion.

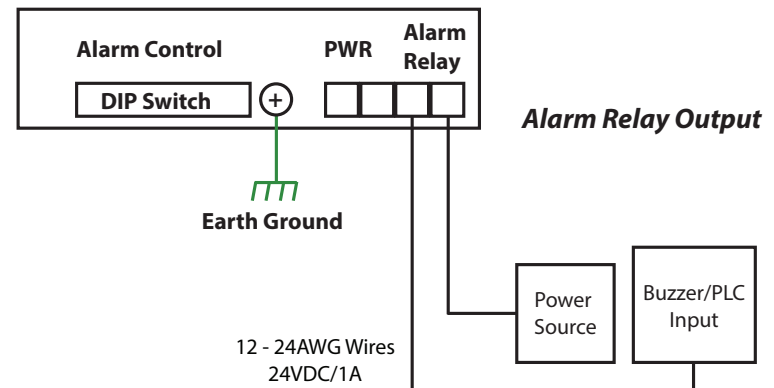

CONNECTING ETHERNET PORTS

Connect one end of an Ethernet cable into the Ethernet port of the ACS7106 and the other end to the attached networking device:

- Ports 1-4 are Fast Ethernet (10/100BASE-TX) PoE that support IEEE 802.3af/802.3at (PoE+)
- Ports 5-6 are Gigabit (10/100/100BASE-TX)

Half and full-duplex connections are supported with auto-negotiated link speed and duplex mode. Auto MDI/MDIX enables direct connection of another hub or switch without the need for crossover cabling. Link/Act LEDs are lit to indicate traffic and link status. See the LEDs subsection on back for more information.

NOTE: The ACS7106 is to be connected to PoE networks without routing to outside the plant.

Always make sure that the cables between the switches and attached devices (for example, switch, hub or workstation) are less than 100 meters (328 feet). Use the following cabling guidelines:

- IEEE 802.3af: 4-pair UTP/STP Category 5 or higher cable, EIA/TIA-568 100-ohm
- IEEE 802.3at: 4-pair UTP/STP Category 5e/6 or higher cable, EIA/TIA-568 100-ohm
- Uplink ports
 - 10BASE-T: 2-pair UTP/STP Category 3, 4, 5, or higher cable, EIA/TIA-568 100 ohm
 - 100BASE-TX: 2-pair UTP/STP Category 5 or higher cable, EIA/TIA-568 100 ohm
 - 1000BASE-TX: 4-pair UTP/STP Category 5 or higher cable, EIA/TIA-568 100 ohm

Pin	10/100BASE-TX PoE (Alternative B)	1000BASE-TX
1	RX +	BI_DA+
2	RX -	BI_DA+
3	TX +	BI_DB+
4	Vport+	BI_DC+
5	Vport+	BI_DC-
6	TX -	BI_DB-
7	Vport-	BI_DD+
8	Vport-	BI_DD-

LEDs

This table provides information about the LEDs on the ACS7106.

LED Name	LED On	LED Blinking	LED Off
PWR - Green	System power ready	Not applicable	System not ready
PoE (P1 - P4) - Green	Valid PoE output and PoE PD is powered	Active PoE	Not applicable
Link/Act (P1 - P6) - Green	Port connected	Port active	Port link down or port not connected
ALM (Alarm) - Red	Relay is active and contacts have been shorted	Not applicable	Relay not activated or no fault condition has occurred

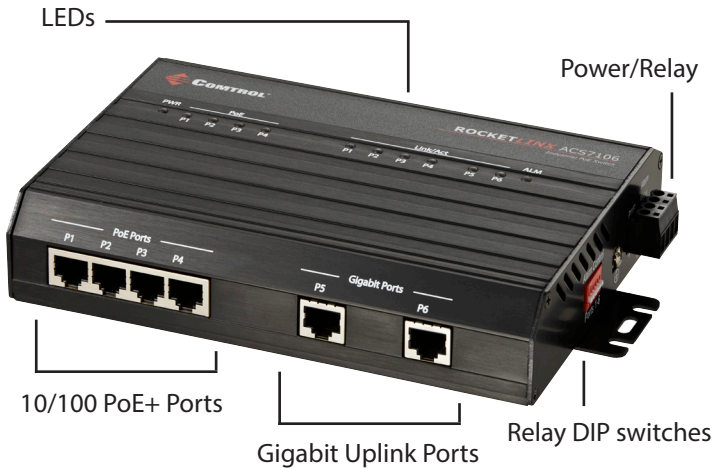

ABOUT CONTROL

For more than 30 years, Control Corporation has been a manufacturer and provider of quality networking and industrial data communication products, specializing in industrial Ethernet and device connectivity. With representation across North America, EMEA, Asia and Latin America, Control sells RocketLinx™ industrial grade Ethernet and Power over Ethernet switches, DeviceMaster® Ethernet device servers and gateways and RocketPort® multiport serial cards through distributors, resellers and integrators worldwide. Providing exceptional product and technical support, Control establishes solutions for a wide range of security, energy, industrial automation and traffic and transportation applications.

CONTACT US

Support	www.control.com/pub/en/support
Downloads	ftp://ftp.control.com/html/ACS7106_main.htm
Website	www.control.com
Phone	(800)926.6876 or (763)957.6000

connect. communicate. control.