

Supporting Customized Failure Models for Distributed Software

Matti A. Hiltunen Vijaykumar Immanuel Richard D. Schlichting

TR 99-04

Supporting Customized Failure Models for Distributed Software¹

Matti A. Hiltunen

Vijaykumar Immanuel

Richard D. Schlichting

TR 99-04

Abstract

The cost of employing software fault-tolerance techniques in distributed systems is strongly related to the type of failures to be tolerated. For example, in terms of the amount of redundancy required and execution time, tolerating a processor crash is much cheaper than tolerating arbitrary (or Byzantine) failures. The tradeoff, of course, is that making stronger assumptions about failures lessens the degree of fault coverage provided by the system. This paper describes an approach to constructing configurable services for distributed systems that allows easy customization of the type of failures to tolerate. For example, using our approach, it is possible to configure custom services across a spectrum of possibilities, from a very efficient but unreliable server group that does not tolerate any failures, to a less efficient but reliable group that tolerates crash, omission, timing, or arbitrary failures. The approach is based on building configurable services as collections of software modules called micro-protocols. Each micro-protocol implements a different semantic property or property variant, and interacts with other micro-protocols using an event-driven model provided by a runtime system. The net result is an enhanced ability to explicitly manage the tradeoff between the level of reliability and cost. In addition to facilitating the choice of failure model, our approach allows service properties such as message ordering and delivery atomicity to be customized for each application.

Feb. 11, 1999

Department of Computer Science
The University of Arizona
Tucson, AZ 85721

¹This work supported in part by the Defense Advanced Research Projects Agency under grant N66001-97-C-8518 and the Office of Naval Research under grant N00014-96-0207.

1 Introduction

Distributed architectures are increasingly used to construct systems that must continue to operate despite failures such as processor crashes. Unfortunately, providing *fault-tolerance* of this type can be expensive. For example, one strategy is to replicate the application on multiple independent machines and then operate them in logical synchrony using the state machine approach [Sch90]. This requires not only redundant hardware, but also sophisticated underlying software such as group atomic multicast [CM84, CASD85] to keep the states of the replicas synchronized.

One factor determining the cost of providing fault tolerance in distributed systems is the type and number of failures to be tolerated. Typically, the type of faults to be tolerated is expressed in terms of *failure models* that range from relatively benign crash or omission failures to arbitrary (or Byzantine [LSM82]) failures. In terms of the amount of redundancy required and execution time, tolerating a processor crash is much cheaper than tolerating Byzantine failures. Furthermore, the cost is determined not only by the failure model, but in many cases also by the number or frequency of the failures expected to occur. For example, a simple replication scheme intended to tolerate n crash failures requires $n + 1$ replicas.

Any realistic system can in principle exhibit failures in any of the failure models, but typically, failures in the more benign classes are more frequent than severe failures. Thus, the choice of failure model for a particular task should be based on the frequency of different types of failures in the given execution environment, as well as the criticality of the task. The tradeoff, of course, is that making stronger assumptions about failures improves the performance of the system, but lessens the degree of fault coverage provided by the system and thus the reliability of the task [Pow92].

This paper describes an approach to constructing configurable services for distributed systems that allows easy customization of the type of failures to be tolerated. For example, using our approach, it is possible to configure custom services such as communication services across a spectrum of possibilities, from a very efficient but unreliable service that does not tolerate any failures, to a less efficient but reliable service that tolerates crash, omission, timing, or arbitrary failures. The approach is based on building configurable services using software modules called *micro-protocols*. Each micro-protocol implements a different semantic property or property variant, and interacts with other micro-protocols using an event-driven model provided by a runtime system. The net result is an enhanced ability to explicitly manage the tradeoff between the level of reliability and cost. As an example, we apply the approach to a group remote procedure call (GRPC) service that can be used by a client to transmit a request to a group of replicated servers. In addition to facilitating the choice of failure model, our approach allows GRPC service properties such as message ordering and delivery atomicity to be customized for each application.

2 Customizing Fault-Tolerance

2.1 Assumptions

We consider a distributed system model in which multiple hosts with no shared memory are connected by a network that provides an unreliable unordered communication mechanism with no upper bound on worst case message transmission time. Hosts can only interact by sending and receiving messages through this communication network. Hosts may fail in arbitrary ways consistent with the assumed failure model, but we assume that the communication network does not experience permanent failures. Among other things, this implies that partitions are not considered.

Given this model, a faulty host can only affect other hosts by not sending a message when it should, by sending a message when it should not, or by sending an incorrect message. A faulty host may exhibit

the incorrect behavior only to a subset of the other hosts.

These kinds of incorrect behaviors can easily be mapped to traditional failure model definitions, including crash, omission, timing, value, and Byzantine.

- *Crash*: A host may permanently halt and hence, fail to send messages. If a host is in the process of sending a message when it crashes, some of the intended receivers may not receive the message.
- *Omission*: A host may repeatedly and irregularly fail to send a message to all or some of the intended receivers, or fail to receive messages.
- *Timing*: A host may send a message earlier or later than expected. The network delaying a message longer than expected may result in a host appearing to have a late timing failure.
- *Value*: A host may send a message with incorrect contents. We assume, however, that if a value faulty host sends a multicast message, all receivers will receive the same message contents, i.e., we assume value failures are symmetric [TP88].
- *Byzantine*: A host may do anything. This means that in addition to value and timing type failures, a faulty host may deliberately attempt to confuse other hosts by sending different versions of a message to different receivers or by impersonating another host.

2.2 Implementation approach

Our approach to providing configurable fault-tolerance is based on implementing distributed services using Cactus [BHSC98, HSH⁺98]. In Cactus, services are implemented as *composite protocols* constructed from fine-grain software modules called micro-protocols that interact using an event-driven execution model. The goal of this paper is to demonstrate that the Cactus model can easily be used to construct micro-protocol suites from which various composite protocols tolerating different classes of failures can be configured.

A micro-protocol is structured as a collection of *event handlers* that are bound to events signaling state changes of interest, e.g. “message arrival from the network”. When an event occurs, all event handlers bound to that event are executed. Events can be raised either explicitly by micro-protocols or implicitly by the Cactus runtime system, as would be the case for the message arrival event above. Execution of handlers is atomic with respect to concurrency, i.e., each handler is executed to completion without interruption.

Event handler binding, event detection, and invocation are implemented by the Cactus runtime system, which is linked with selected micro-protocols to form a composite protocol implementing the custom service. The runtime also supports shared data (e.g., messages) that can be accessed by all micro-protocols configured into the composite protocol. Once created, a composite protocol can be composed in a traditional hierarchical manner with other protocols to form the application’s networking subsystem.

The two primary event-handling operations are `bind()`, which specifies a handler to be executed when a specified event occurs, and `raise()`, which raises a specified event with either blocking or non-blocking invocation semantics. Certain events are also raised implicitly by the Cactus runtime system, such as the message arrival event above. Other operations are available for creating and deleting events, stopping event execution, canceling a delayed event, and unbinding event handlers from events.

Cactus has been implemented on the OSF/RI MK 7.3 Mach operating system and CORDS [TMR96], a variant of the *x*-kernel system for building network software [HP91]. On this platform, each composite protocol exports the same external interface as CORDS protocols and thus, can be combined transparently with such protocols. Communication between CORDS protocols is based on a push/pop paradigm, where a

higher level protocol pushes a message to a lower level protocol and a lower level protocol pops a message to a higher level protocol.

2.3 Providing fault-tolerance

The focus of this paper is on constructing configurable distributed services that can exploit existing algorithms for tolerating different classes of failures. The ideal would be to encapsulate such algorithms as “fault-tolerance modules” that could be combined with any distributed service *S* to automatically create a version of *S* that could tolerate a selected failure type. While feasible in certain cases [AS94, FP98], our goal is instead to provide fault-tolerance modules—implemented as Cactus micro-protocols—that are specific to a given service such as atomic multicast [CM84, CASD85], group RPC [Nel81, Che86], group membership [Bir85, KGR91], or distributed transactions [BHG87].

The semantic differences between distributed services are the main motivation for constructing service-specific micro-protocols. For example, in group RPC, a non-faulty server is expected to send a reply message, but no such requirement exists for asynchronous primitives such as atomic multicast. This means that the definition of correct behavior—and thus, the definition of faulty behavior—is service specific. As the result, a micro-protocol whose role is to add fault-tolerance to a given service must be constructed with the semantics of that service in mind.

Semantic variations between versions of the same service also affect what fault-tolerance modules must do. For example, if a multicast service provides atomic delivery of messages to all members of a group, a fault-tolerance module must handle the case when a message only reaches a subset of intended destinations because the sending host fails while transmitting the message. However, if the multicast does not provide atomic delivery, a fault-tolerance module does not need to address such an incomplete transmission. Finally, depending on the specifics of the service, it may be possible to reduce the cost of fault tolerance by piggybacking fault-tolerance information on application messages.

In our approach, a distributed service is implemented as a composite protocol configured from both *service micro-protocols* and *fault-tolerance micro-protocols*. Service micro-protocols provide the basic functionality of the service and can be written independently of the failure model. Fault-tolerance micro-protocols add tolerance to failures and are specific to a given failure model. Fault-tolerance micro-protocols are implemented as collections of event handlers bound to particular events used by the service micro-protocols. These events would typically include those indicating the arrival of a message from lower level protocols, as well as the imminent departure of a message from the composite protocol to the next lower level. The `bind()` operation has an ordering argument that is used to ensure that handlers in the fault-tolerance micro-protocols are executed before or after handlers in the service micro-protocols when necessary. This allows, for example, messages from hosts declared faulty to be filtered out. Thus, the event mechanism allows execution of fault-tolerance micro-protocols to be transparently interleaved with service micro-protocols as required.

2.4 Fault-tolerance micro-protocols

In general, fault-tolerance micro-protocols must prevent a faulty host from interfering with the operation of non-faulty hosts. The different failure models allow faulty hosts to interfere in different ways. For the crash failure model, a faulty host fails to send a message when it should, which may cause a non-faulty host to wait forever for a message. Thus, a fault-tolerance module designed for this type of failure must ensure that any such wait is eventually terminated. For example, in a group-oriented service such as atomic multicast, this can be done by removing the faulty host from the membership. A crash failure can be

detected by monitoring if *any* message is received from a host within a given time period. No agreement between hosts is necessary since we assume a crash failure is eventually detected by all the other hosts.

Omission failures can be divided into send and receive omission failures. Send omission failures are different from crash failures, since a faulty host may continue to send messages after it becomes faulty. Detecting that messages are missing from a sequence is naturally service specific, but for many services, it can be based on the use of consecutive message sequence numbers. Agreement between hosts is required to distribute local omission detections, since a faulty host may fail to send a message only to some hosts, and thus, all hosts may not locally detect the failure.

Omission to receive failures are more difficult to handle, since a faulty host may mistake the symptoms for send omission failures of other hosts. Thus, distribution of the detection information is not enough and a majority vote is required. In this case, a host can locally only *suspect* the failure of another host until the agreement is completed. A host may suspect its own receive omission failure if it does not receive messages from any other host or if other hosts repeatedly disagree with its local detection.

Timing failures can be similarly divided to early and late timing failures. The concept of a message being early or late is even more service specific than omissions; that is, no standard mechanism such as sequence numbers can be used to detect timing failures. Late timing failures can often be detected by setting a local timer event to fire at the time when a message should arrive. If the message arrives by this time, the timer event is canceled; otherwise, the event handler declares the expected sender of the message to be faulty. Agreement on late timing failures is similar to agreement on send omission failures, i.e., it is sufficient to distribute the local detection information. However, a host with an early timing failure may suspect the failure of other hosts, so an agreement phase similar to that for receive omission failures is required.

Note that the potentially unbounded worst case transmission time of the network may cause failure detection mechanisms to falsely detect host failures of any of the above types. The probability of such false detections can be reduced by allowing a longer transmission time before a failure is suspected, by using retransmissions, and by using agreement algorithms. Nevertheless, a false detection may still occur and must be dealt with by forcing the given host to simulate failure and recovery to rejoin the group. Note that although maintaining such group membership in an asynchronous system is theoretically impossible [FLP85], practical systems have demonstrated that such heuristics result in operational systems.

All of the above fault-tolerance micro-protocols deal with failures in the time domain, meaning that only one is configured into any given service. However, failures in the value domain are orthogonal, so value failure micro-protocols could be used together with any of the above. Detecting value failures is completely service specific. For example, it may be based on inspecting the format of a message or the range of the values if there is some known range of reasonable values. Or, if the service involves replication such as group RPC, the responses from different hosts can be compared to detect value failures. These types of checks can be implemented easily by a micro-protocol that intercepts and checks messages before they get to the service micro-protocols.

There is no clear cut boundary between value and arbitrary failures, so typically a value failure micro-protocol would handle a fixed set of value failures, with more extensive failures handled by a micro-protocol dealing with arbitrary failures if desired. An additional possibility raised with arbitrary failures is that a faulty host may try to impersonate another host. Thus, the arbitrary failure micro-protocols add message authentication, i.e., all messages are signed using RSA encryption and the signature is checked at the receiver before the message is forwarded to the service micro-protocols. Byzantine agreement rather than simple voting algorithms are required to agree on host failures. Message atomicity guarantees must also be implemented using Byzantine algorithms.

3 Customizable Group RPC Service

As an example of how to apply the above principles to a specific distributed service, we present a customizable group RPC (GRPC) service that clients use to access a group of servers. We assume servers maintain data that can be queried and updated, with the consistency requirements for the data depending on the application. Host recovery is not considered.

The basic assumptions about the execution environment are the same as in section 2. We assume a server group of N servers and an arbitrary number of clients, where all servers are assumed to agree on the server group membership, but the clients are not required to have complete server group information.

3.1 GRPC properties

The GRPC service may be customized to guarantee the following properties.

- *Synchronous.* The client is blocked until a response is received or the call is terminated as unsuccessful.
- *Asynchronous.* The client is not blocked and the result of the call is returned to the client application using an upcall to a designated client procedure.
- *Unique.* Each call is executed at each server no more than one time.
- *FIFO.* The calls send by a given client are processed in the same order by all servers.
- *Atomicity.* All correct servers will execute the same set of calls. This property is guaranteed even if a client does not send a request to all servers in the group.
- *Total order.* All correct servers execute the same calls in the same order.

Total order guarantees that all the correct servers have a consistent state provided that their initial states are consistent. Note, however, that atomicity is sufficient to guarantee consistency if all calls are commutative.

No guarantees are made concerning faulty clients or servers, except that if a correct server processes a call from a faulty client, all correct servers will process this call if atomicity is guaranteed.

3.2 GRPC failure models

The definitions of faulty behavior for each failure model in section 2 can be refined since hosts now have specific roles as servers or clients, and the communication patterns are more restricted. For failures in time domain, we are only concerned about server failures; the effects of a client failing to send a request to all servers is covered by the assumption that a faulty client might not send requests to all servers. A host is omission faulty if it does not provide a reply to a client or if it fails to send any of the periodic messages exchanged between servers. The definition of a value faulty host depends on the semantics of the GRPC. For example, if the state of the servers is supposed to be identical, a server is value faulty if its reply to a call differs from the other replies. All other incorrect behavior is considered to be an arbitrary fault.

The goal of the GRPC service is to guarantee that correct clients receive a correct result to their calls given at most M faulty servers.

3.3 Algorithms

This section outlines the algorithms employed to implement the different options and properties of GRPC.

3.3.1 Communication algorithms

Multicast is implemented as multiple point-to-point transmissions. A host establishes and maintains the state of *links* with the hosts with which it wishes to communicate. For example, a client creates a link for each server it sends a request to, and a server creates a link with a client on receiving a request from it. Links between servers are established for ensuring atomicity, total order and similar properties. Reliability of the communication is ensured by a modified version of the sliding window protocol on each link that provides reliable but un-ordered delivery of messages. Hosts timeout and retransmit messages a fixed number of times; when this value is exceeded, the host raises a host-failure event, notifying other micro-protocols of the suspected failure. Each link is bi-directional and acknowledgments are piggy-backed on data messages whenever possible.

3.3.2 Fault-tolerance algorithms

The following algorithms are used to handle failures within the different failure classes. Both servers and clients maintain server group membership information. As per our assumptions, the servers must agree on the membership, while each client maintains its own approximation. A client detects that a server is faulty when it fails to receive a response, which may be either a reply or an acknowledgment. The server is declared faulty locally in this case and subsequent requests will not be sent to that server.

Crash, omission, and timing failures are detected by observing the communication from other hosts. In particular, a host is considered failed if it does not acknowledge a message after a fixed number of retransmissions or if a server fails to send a response or forward a request within a certain time period. Note that the same detection mechanism works for omission and timing failures because it is message specific, i.e., if there is any message that is not acknowledged on time or sent on time, the responsible host is considered faulty.

Although local detection of these failures is similar, the agreement phase varies depending on the failure model. Crash failures do not require any agreement phase, since each host will eventually detect the failure independently. Send omission and late timing failures require the local detection information to be shared between servers. This is done by piggybacking the information on regular messages, which ensures that all non-faulty servers eventually agree on the failure.

Receive omissions and early timing failures require agreement, since a faulty host may suspect correct hosts due to a missing message or a fast local clock. Thus, when a failure is detected, the host is declared suspect. Information about the failure is included in the messages exchanged by servers and when a sufficient number of servers suspect the host, it is declared faulty. The sufficient number in this case is $M+1$, where M is the maximum number of faulty hosts. Thus, even if the M faulty hosts have a receive omission or early timing failure and suspect some non-faulty host, the non-faulty host will not be removed from the membership. Naturally, since the M faulty hosts may also be crash faulty, M must be small enough to ensure there will be $M+1$ votes from correct hosts. Thus, M must be less than $N/2$.

Our design does not provide a predefined algorithm for detecting value failures. This is because the intended uses of the group RPC may vary, from accessing completely identical replicated servers to parallel access of non-identical servers. Also, the data types of the requests and responses are naturally application specific. However, our design allows the client application to specify a voting function that is used to combine the responses. The voting function may employ techniques such as majority voting, range

checks, and other application-specific sanity checks. The voting function may also raise events to notify the composite protocol about server failures.

Byzantine failures require a voting protocol based on Byzantine agreement. Since we use authenticated messages, no additional redundancy is required compared with receive omission and timing failures. That is, $M+1$ votes are required, where M is less than $N/2$.

3.3.3 Service property algorithms

The implementation of the basic GRPC properties are all based on well-known algorithms. Synchronous calls are implemented by blocking the client thread on a private semaphore until the call is completed. Note, however, that the decision on when a call is completed depends on the failure model. Asynchronous calls return immediately, and the eventual result is delivered to the client using an upcall. Unique execution is based on identifying each request based on a (client-id, sequence number) pair, except in the Byzantine case, where a client-id, sequence number, and the actual data bytes are used to uniquely identify a client request. The latter is necessary to guard against a faulty client sending different byte sequences with the same client-id and sequence number to different servers. Finally, FIFO message ordering is implemented by each server queuing client requests until all calls with lower sequence numbers from the same client are received. If an expected call is not received within a specified period of time, the client is declared faulty. In this case, all calls from that client are removed from the queue.

The atomicity algorithm in the non-Byzantine case is flexible and offers the tradeoff between the cost of atomicity and how quickly each server is guaranteed to receive each request. The cost, in particular, can range from $O(1)$ to $O(N^2)$. The basic idea of the algorithm is that each server maintains a list of identifiers (client-id, sequence number) of the requests that it has received and a circular list of the other servers. When a new request is received, its identifier is added to the list and the list is sent to the k next servers on the circular list. If $k = 1$, each server will send one extra message and thus, the cost of atomicity is $O(N)$. On receiving the list, a server checks if it has received all requests in the list; if not, it asks the sender of the list to forward the missing requests. A server removes a request from its list after it knows that a list containing the request has been sent to all the servers at least once. Naturally, the cost of atomicity can be reduced further by sending the list to the next k servers only after some number j of new requests have been received.

The algorithm for total order in the non-Byzantine case builds on the atomicity algorithm. One of the servers is elected as a coordinator to order all requests. The order is propagated to all the servers on the request id lists, i.e., for each request, the list now has client-id, sequence number, and order number. Since a request cannot be processed before the order is received, the standard slowly propagating atomicity algorithm would cause too much delay. Thus, the coordinator always sends the summary message to all the servers. A coordinator failure is handled by a multiphase algorithm in which the process with the next highest IP number becomes the new coordinator. It collects information from all other servers to determine the last request ordered by the previous coordinator, and then resumes normal processing.

The above total ordering algorithm does not guarantee FIFO ordering. Thus, if FIFO and total order are both required, an additional FIFO algorithm is used. The only difference with the regular FIFO algorithm is that the FIFO queue now contains totally ordered requests.

The algorithms used for Byzantine failures are based on Byzantine agreement with signed messages [LSM82], in which multiple rounds of message exchange are used. In each round, each server sends a message to all the other servers containing a set of requests. The specific algorithm involves grouping consecutive rounds together into a *block*, which is defined as $M+1$ rounds. In each round, each server signs and forwards the requests it receives to all other servers. Any request received from a client during a block is queued and handled in the next block. When a server receives a forwarded request from another

server, it signs and forwards it to all servers that have not signed the request. After $M+1$ rounds, at least one non-faulty server has seen the message and hence, forwarded it to all servers. Then, the processing of the next block is started. If included, a total order micro-protocol orders the requests in each block after it is completed. Since all requests in a block are seen by all servers by the end of the block, a local deterministic ordering is sufficient.

For every request, there is an exchange of messages between every pair of servers, meaning that the algorithm uses $O(N^2)$ messages. The latency may be high, however, since every request has to wait for an entire block to be processed before being serviced by any server. Also, RSA signing and verification take considerable time, adding to the latency.

4 Implementation

The implementation of the configurable GRPC uses Cactus, where micro-protocols are used to implement each of the different logical algorithms described in section 3.3.

4.1 Client micro-protocols

Some micro-protocols are used on both clients and servers, but the set on the client is smaller and thus, simpler as a starting point. Figure 1 represents these micro-protocols and how they interact using Cactus events. Compulsory micro-protocols are represented by solid boxes and optional with dashed boxes. The numbered arrows represent events, with single-headed arrows representing non-blocking events and double-headed arrows representing blocking events. In either case, the micro-protocol(s) pointed to by the solid head service the event, i.e., they have an event handler bound for the event. Finally, A, B, and C denote interactions between CORDS protocols, with A being a message pop, B being a message push, and C being a synchronous call. Note that the custom interfaces at the top and bottom of the composite protocol translate the interaction with other CORDS protocols into events.

As indicated by the figure, the client has only two compulsory and two optional micro-protocols. The R_NET micro-protocol implements the reliable communication using a sliding window protocol. It unpacks the message headers and removes piggybacked acknowledgments before forwarding the message to other micro-protocols using appropriate events. If it suspects a failure of a server based on a delayed or missing response, it raises a failure event. If a server failure is declared, the micro-protocol stops accepting its messages. The ACCEPT micro-protocol implements the synchronous and asynchronous call variations. It sends the client request to all servers and collects responses until a required number is received. At this point, the response is returned to the client. The micro-protocol keeps track of functioning servers, so that it knows when every non-faulty server has responded and thus, the call is completed.

The optional CRASH micro-protocol waits for `suspect_failure` events raised by other micro-protocols, and raises either a `server_failed` event or `client_failed` event depending on the role of the failed site. The optional RSA micro-protocol signs messages and verifies message signatures using the RSA algorithm.

4.2 Server micro-protocols

The server micro-protocols and their interactions are presented in figure 2. Some of the micro-protocols—R_NET, RSA, and CRASH—and events are identical to those on the client, but a number of new micro-protocols and events are introduced.

The figure indicates that each configuration of the service must have either BASIC or FIFO micro-protocols. The BASIC micro-protocol simply forwards requests to the application level server, matches

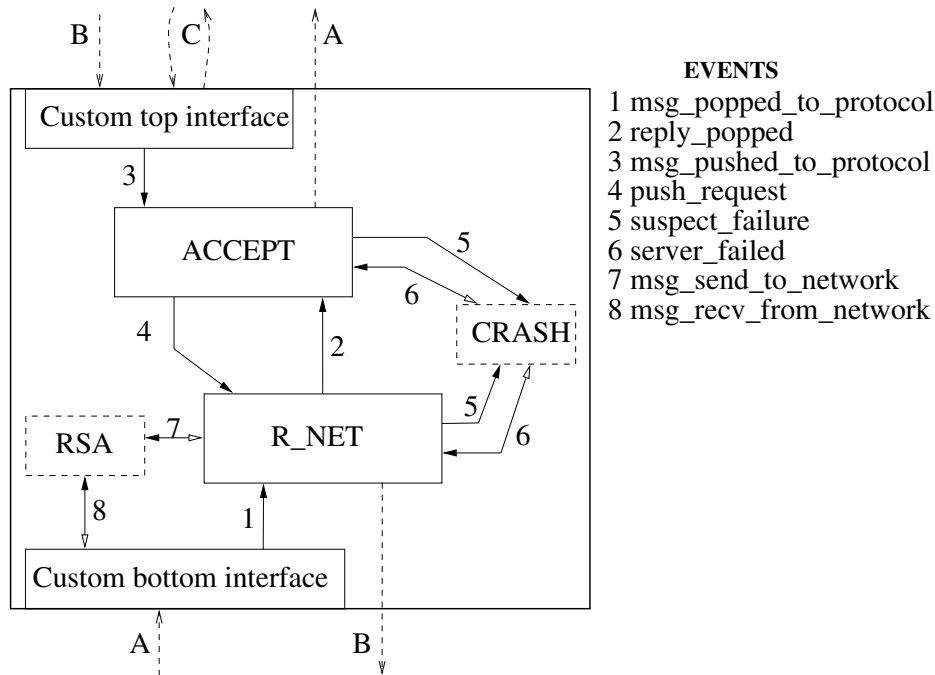

Figure 1: Client micro-protocols.

responses to requests, and returns responses to the client using the R_NET micro-protocol. The FIFO micro-protocol implements FIFO ordering on top of totally ordered or non-ordered messages, maintaining the necessary queues and other data structures as described in section 3.3. It also raises the `suspect_failure` event if a missing message is not received within a specified period of time, and has handlers for the client and server failure events so that it can clear any data structures for the failed hosts.

The optional `ATOMIC`, `TOTAL`, and `BYZ_ATOMIC` micro-protocols implement atomicity and total ordering for non-Byzantine and Byzantine failures using the algorithms described in section 3.3. In particular, the `ATOMIC` micro-protocol maintains the list of request identifiers and sends it out at the desired frequency. It also requests retransmissions if it detects that a missing message based on a request list it received, and handles retransmission requests from other servers. The `TOTAL` micro-protocol implements coordinator-based total ordering, including dealing with coordinator failures. The details are omitted here for brevity.

The `BYZ_ATOMIC` micro-protocol implements the basic Byzantine agreement algorithm using authentication, collecting requests in a queue to wait for the beginning of the block in which this set of requests are processed. Note that all requests forwarded by other servers must be checked for authenticity — each forwarded request is signed by all the servers that have forwarded the request. In every round, a server forwards each of the messages it received in the previous round to all servers that have not yet signed the message.

Interactions between micro-protocols are implemented using events. If any of `ATOMIC`, `TOTAL`, or `BYZ_ATOMIC` are included in a configuration, they have their event-handlers bound to the event `request_popped` before the handlers of `BASIC` or `FIFO`, so that they can stop the event and prevent `BASIC` or `FIFO` from seeing these messages. Later, when all the required properties are satisfied for the messages,

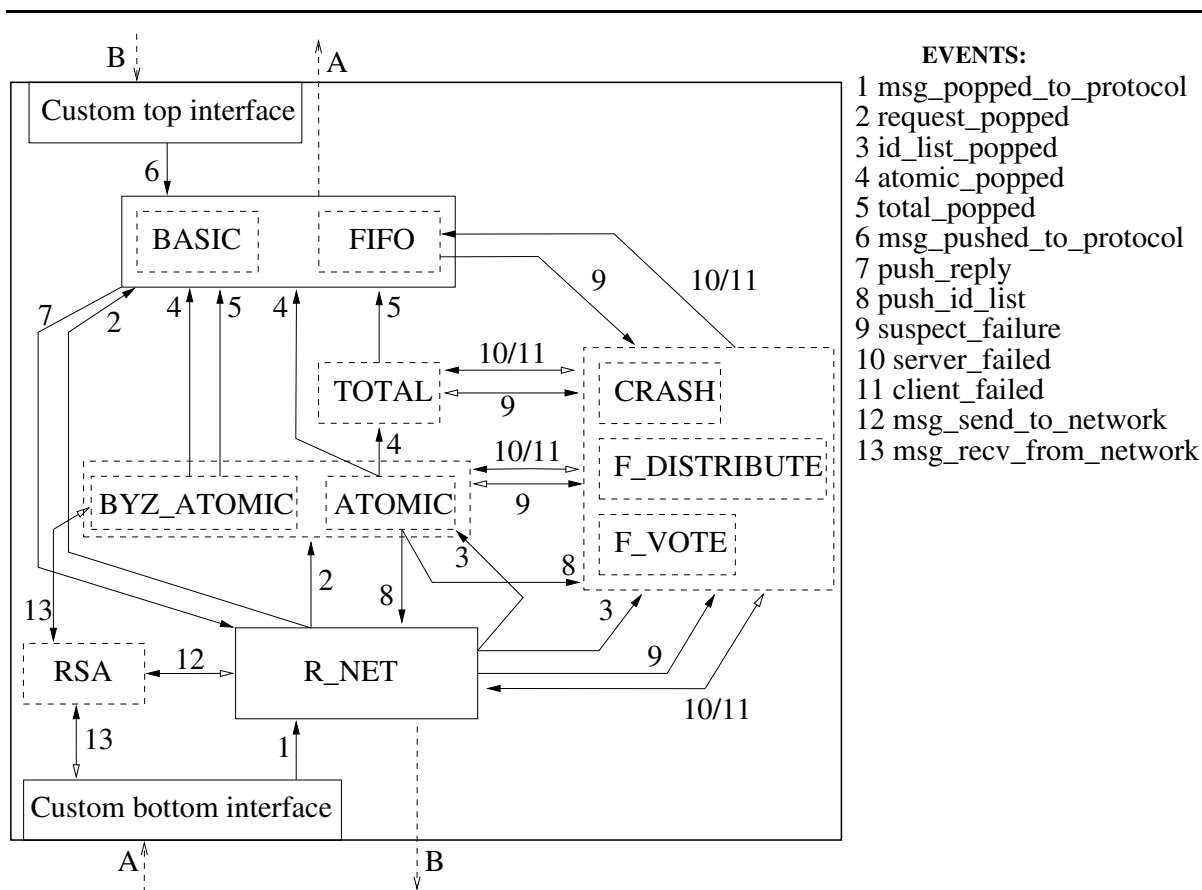

Figure 2: Server micro-protocols

these micro-protocols notify BASIC or FIFO using different events. However, if none of these three are in a configuration, the request_popped event will notify BASIC or FIFO, which will then deliver the request to the application-level server.

The server micro-protocol suite includes two more optional failure-handling micro-protocols, F_VOTE and F_DISTRIBUTE. F_DISTRIBUTE handles send omission and late timing failures. It converts local failure detections—i.e., the suspect_failure event—into an agreed membership change event server_failed or client_failed. It also distributes the local failure detection information by piggybacking it on the request identifier messages. The piggybacking is done when push_id_list is raised. It also extracts any failure information from the request identifier messages at the receiver and raises the appropriate failure events.

F_VOTE implements the voting required for receive omission, early timing, and Byzantine failures by also piggybacking the local suspicion information and raising the appropriate events when at least $M+1$ hosts suspect a failure. Note that in the Byzantine case, the suspicion information is piggybacked with the client request messages in the agreement protocol. As a result, no host can send conflicting detection information to other hosts undetected.

4.3 Performance

The configurable GRPC service allows a tradeoff between the number of failures that can be tolerated and the service response time. While crash failures are relatively inexpensive to tolerate, the cost of fault-tolerance increases as the more inclusive failure models are used. To measure this relative cost, as well as the cost of the various service properties, we tested the service on a cluster of Pentium PCs running the MK 7.3 operating system, and connected by a 10Mb Ethernet. As a reference point, the UDP and IP roundtrip times on this platform are around 1.15 ms and 1.12 ms, respectively.

The following execution times are average response times in milliseconds from tests with clients executing synchronous RPC calls on a server group consisting of one to three servers depending on the failure model. The number of servers was chosen so that one failure of the given type could be tolerated. The average response time for one group RPC call is calculated by dividing the total time required to make 1000 consecutive synchronous RPC calls by 1000, except in the Byzantine case where the average was calculated for 10 requests.

Failure Model/Properties	Clients	Servers	None	FIFO	Atomic	Total
None	1	1	3.3	3.3	3.5	3.6
	2	1	5.1	5.1	5.6	5.9
Crash	1	2	4.2	4.2	5.7	6.2
	2	2	5.1	5.1	10.9	13.4
Send omission and late timing	1	2	4.2	4.1	5.8	6.6
	2	2	5.1	5.0	10.7	13.8
Receive omission and early timing	1	3	5.2	5.3	7.16	10.5
Byzantine	1	3	1993.0	2181.0	18923.0	18924.0

Table 1: Average response time (in msec.)

The most important aspect of this table are the relative costs. A number of observations, most of which are not surprising considering the algorithms used, can be made from these numbers. As far as properties are concerned, the cost of adding FIFO is insignificant. On the other hand, atomicity and total ordering, which builds on atomicity, increase the response time considerably. This is to be expected because FIFO does not introduce extra messages, while atomicity and total order require a message exchange between servers. Also, note that response time increases with the number of clients because of the extra load on the servers.

As far as the failure models are concerned, the tests indicate a definite increase in response time as the complexity of the failure model increases. In the case of crash, omission, and timing failures, this is mostly due to the increased number of server replicas required to tolerate the failures. Considering the actual fault-tolerance algorithms used in these cases, the cost of the failure detection mechanism is the same regardless of the failure model. However, if a failure were to occur during the execution of an RPC call, the complexity, and thus the cost, of the agreement or voting algorithm would depend on the failure model. The cost difference increases more when considering complex properties such as atomicity and total order. This follows because these properties require communication between servers and thus, are more sensitive to the number of servers required.

The cost of tolerating Byzantine failures is large compared to any of the other failure models. The

cost is partially due to the overhead of signing messages using RSA and partially due to the cost incurred by multiple rounds of message passing. We used an existing software implementation of RSA based on 512-bit keys. The None and FIFO columns only include the cost of authentication, since if atomicity is not required, the Byzantine agreement protocol is not executed. The Atomic and Total columns include the rounds algorithms and since the goal is to tolerate a single failure, the algorithm requires two rounds. The rounds algorithm is synchronous, that is, the second round only starts after the first round is completed. A timeout is used to terminate a round to ensure progress if all servers do not reply. In this test, the timeout was set to 8000 ms. This number is determined by estimating how long it takes for a host to complete a round, including encrypting and sending its set of messages and decrypting all the sets of messages it receives. If the round timeout is set too small, hosts may be unnecessarily suspected of failures.

We also measured the corresponding times for asynchronous calls. They were consistently lower—up to 30% less—than the corresponding synchronous call times. This is because asynchronous calls allow a client to issue a number of concurrent RPC calls and thus, increase the overlap between computation and communication. When the number of clients increases, however, the servers become saturated and the benefit of asynchronous calls is considerably reduced.

5 Related work

Related work on fault-tolerant distributed services is extensive. Most implementations of distributed services such as atomic multicast, membership, group RPC, synchronized clocks, and transactions, tolerate at least crash failures, and some tolerate more complex failures. Typically, however, each service can only tolerate a single class of failures and is not configurable. Moreover, each implementation typically provides a different API, and relies on a specific hardware and software configuration.

Closer to the idea of customizing failure models is the family of group multicast protocols in [CASD85], which has one protocol each for crash, omission, timing, and arbitrary failures. Another example of a family of protocols is a set of group multicast protocols that adapt to crash, omission, and arbitrary failures, respectively [CHS98]. These protocols are not configurable in the same sense as our approach, however. In particular, rather than customizing one protocol, the user must select from a related collection of protocols.

Other work dealing with multiple failure models is that on hybrid fault models [TP88, LR93, WHS95]. The basic idea is to detect a range of different types of failures at the same time by using multiple failure detection techniques. This approach allows the system to tolerate a larger number of failures than traditional Byzantine algorithms, since simpler failures that require less redundancy can be distinguished from true Byzantine failures. Some algorithms designed for hybrid fault models, in particular [WHS95], allow specification of the maximum number of faults to be tolerated for each different fault model. Although such an algorithm could exhibit comparable flexibility to our approach with respect to choice of failure model, our approach allows greater optimization of the algorithm used in each situation, since each failure model has a micro-protocol of its own.

A number of object-oriented systems support customization of fault-tolerance by allowing fault-tolerance techniques such as replication, checkpointing, and checksum error detection to be configured into an object using reflection [AS94, SA94, FNP⁺95, FP98]. Although these systems support customization of fault tolerance in terms of techniques, they do not directly address the issues of customizing the failure model to be tolerated. Indeed, most existing work in this area appears to focus only on tolerating crash failures.

Finally, other work on group RPC services has focused on customizing service properties other than fault tolerance. The event-driven model described in this paper has been used to construct group RPC services with customizable service properties such as ordering, uniqueness, orphan handling, and bounded

termination [HS95, BS95], but no support for customization of failure model. An approach for RPC customization based on specification languages is presented in [HR94]. Finally, the *x*-kernel has been used to construct highly-modular, but not configurable, RPC services [HPOA89].

6 Conclusions

The choice of a failure model is a key factor in determining the performance of a system, as well as its fault coverage. The approach presented in this paper makes it easy to construct customized services that can tolerate a given class of failures. It is based on separating the implementation of service properties and fault tolerance guarantees to the greatest extent possible using fine-grain micro-protocols and the event-based programming style in the Cactus system. We demonstrated the viability of the approach by presenting the design and implementation of a group RPC service that supports multiple classes of failures. Performance results verify the cost incurred by using a more inclusive failure model, even when failures do not occur.

Future work will concentrate in a number of areas. One is applying this approach to other distributed services, such as a security service and a distributed file system. Another is investigating techniques to reduce the cost of fault tolerance by using runtime adaptation to dynamically change the class of failures being tolerated [CHS98]. Finally, we also intend to analyze other quality of service (QoS) tradeoffs that arise in distributed computing systems designed to provide fault-tolerance, real-time, and security guarantees.

References

- [AS94] G. Agha and D. Sturman. A methodology for adapting to patterns of faults. In G. Koob and C. Lau, editors, *Foundations of Dependable Computing: Models and Frameworks for Dependable Systems*, pages 23–60. Kluwer Academic Publishers, 1994.
- [BHG87] P. Bernstein, V. Hadzilacos, and N. Goodman. *Concurrency Control and Recovery in Database Systems*. Addison-Wesley Publishing Company, 1987.
- [BHSC98] N. Bhatti, M. Hiltunen, R. Schlichting, and W. Chiu. Coyote: A system for constructing fine-grain configurable communication services. *ACM Transactions on Computer Systems*, 16(4):321–366, Nov 1998.
- [Bir85] K. Birman. Replication and fault-tolerance in the Isis system. In *Proceedings of the 10th ACM Symposium on Operating System Principles*, pages 79–86, Orcas Island, WA, Dec 1985.
- [BS95] N. Bhatti and R. Schlichting. A system for constructing configurable high-level protocols. In *Proceedings of SIGCOMM '95*, pages 138–150, Cambridge, MA, Aug 1995.
- [CASD85] F. Cristian, H. Aghili, R. Strong, and D. Dolev. Atomic broadcast: From simple message diffusion to Byzantine agreement. In *Proceedings of the 15th Symposium on Fault-Tolerant Computing*, pages 200–206, Ann Arbor, MI, Jun 1985.
- [Che86] D. Cheriton. VMTP: A transport protocol for the next generation of communication systems. In *Proceedings of SIGCOMM '86 Symposium on Communication Architectures and Protocols*, pages 406–415, Aug 1986.

- [CHS98] I. Chang, M. Hiltunen, and R. Schlichting. Affordable fault tolerance through adaptation. In J. Rolin, editor, *Parallel and Distributed Processing, Lecture Notes in Computer Science 1388*, pages 585–603. Springer, Apr 1998.
- [CM84] J. Chang and N. Maxemchuk. Reliable broadcast protocols. *ACM Transactions on Computer Systems*, 2(3):251–273, Aug 1984.
- [FLP85] M. Fischer, N. Lynch, and M. Paterson. Impossibility of distributed consensus with one faulty process. *Journal of the ACM*, 32(2):374–382, Apr 1985.
- [FNP⁺95] J.-C. Fabre, V. Nicomette, T. Perennou, R. Stroud, and Z. Wu. Implementing fault tolerant applications using reflective object-oriented programming. In *Proceedings of the 25th International Symposium on Fault-Tolerant Computing*, pages 489–498, Pasadena, CA, Jun 1995.
- [FP98] J.-C. Fabre and T. Perennou. A metaobject architecture for fault tolerant distributed systems: The FRIENDS approach. *IEEE Transactions on Computers, Special Issue on Dependability of Computing Systems*, 47(1):78–95, Jan 1998.
- [HP91] N. Hutchinson and L. Peterson. The *x*-kernel: An architecture for implementing network protocols. *IEEE Transactions on Software Engineering*, 17(1):64–76, Jan 1991.
- [HPOA89] N. Hutchinson, L. Peterson, S. O’Malley, and M. Abbott. RPC in the *x*-kernel: Evaluating new design techniques. In *Proceedings of the 12th ACM Symposium on Operating Systems Principles*, pages 91–101, Litchfield Park, AZ, Dec 1989.
- [HR94] Y.-M. Huang and C. Ravishankar. Designing an agent synthesis system for cross-RPC communication. *IEEE Transactions on Software Engineering*, 19(3):188–198, Mar 1994.
- [HS95] M. Hiltunen and R. Schlichting. Constructing a configurable group RPC service. In *Proceedings of the 15th International Conference on Distributed Computing Systems*, pages 288–295, Vancouver, BC, Canada, May 1995.
- [HSH⁺98] M. Hiltunen, R. Schlichting, X. Han, M. Cardozo, and R. Das. Real-time dependable channels: Customizing QoS attributes for distributed systems. Technical Report 98-06, Department of Computer Science, University of Arizona, Tucson, AZ, Jul 1998. To appear in *IEEE Transactions on Parallel and Distributed Systems*.
- [KGR91] H. Kopetz, G. Grunsteidl, and J. Reisinger. Fault-tolerant membership service in a synchronous distributed real-time system. In A. Avizienis and J.C. Laprie, editors, *Dependable Computing for Critical Applications*, pages 411–429. Springer-Verlag, Wien, 1991.
- [LR93] P. Lincoln and J. Rushby. A formally verified algorithm for interactive consistency under a hybrid fault model. In *Proceedings of the 23rd International Symposium on Fault-Tolerant Computing*, pages 402–411, 1993.
- [LSM82] L. Lamport, R. Shostak, and Pease M. The Byzantine generals problem. *ACM Transactions on Programming Languages and Systems*, 4(3):382–401, Jul 1982.
- [Nel81] B.J. Nelson. *Remote Procedure Call*. PhD thesis, Dept of Computer Science, Carnegie-Mellon University, Pittsburgh, PA, 1981.

- [Pow92] D. Powell. Failure mode assumptions and assumption coverage. In *Proceedings of the 22nd IEEE Symposium on Fault-Tolerant Computing*, pages 386–395, 1992.
- [SA94] D. Sturman and G. Agha. A protocol description language for customizing failure semantics. In *Proceedings of the 13th Symposium on Reliable Distributed Systems*, pages 148–157, Oct 1994.
- [Sch90] F. Schneider. Implementing fault-tolerant services using the state machine approach: A tutorial. *ACM Computing Surveys*, 22(4):299–319, Dec 1990.
- [TMR96] F. Travostino, E. Menze, and F. Reynolds. Paths: Programming with system resources in support of real-time distributed applications. In *Proceedings of the IEEE Workshop on Object-Oriented Real-Time Dependable Systems*, Feb 1996.
- [TP88] P. Thambidurai and Y.-K. Park. Interactive consistency with multiple failure modes. In *Proceedings of the 7th Symposium on Reliable Distributed Systems*, pages 93–100, Oct 1988.
- [WHS95] C. Walter, M. Hugue, and N. Suri. Continual on-line diagnosis of hybrid faults. In F. Cristian, G. Le Lann, and T. Lunt, editors, *Dependable Computing for Critical Applications 4*, pages 233–249. Springer-Verlag, Wien, 1995.