



.....
HAWK 2LP Family:
.....

ST32430N/ND
.....

ST31230N/ND
.....

.....
Installation Guide
.....

Contents

Introduction	1
Electromagnetic interference	1
Before you begin	3
Installation overview	8
Product Repair.....	10
Shipping	11
Product Repair and return information	11
Technical support services	12
Hawk 2LP family product information	15
Initial set-up information	17
Drive configuration	22
Drive installation	30

© 1994 Seagate Technology, Inc. All rights reserved
Publication Number: 77767473, Revision B
October 1994

Seagate®, Seagate Technology® and the Seagate logo are registered trademarks of Seagate Technology, Inc. Hawk™, SeaFAX™, SeaFONE™, SeaTDD™, and SeaBOARD™, are trademarks of Seagate Technology, Inc. Other product names are registered trademarks or trademarks of their own.

Seagate reserves the right to change, without notice, product offerings or specifications. No part of this publication may be reproduced in any form without written permission of Seagate Technology, Inc.

Introduction

This manual is organized to assist you in the installation and operation of your Seagate Hawk 2LP Family disc drive. Family models are listed in Hawk 2LP Family Product Information section. It also provides information to aid in obtaining service for the drive.

Before attempting any installation, please read through all applicable sections of this document, including all warnings and cautions.

Warning.

This equipment generates, uses, and can radiate radio frequency energy and if not installed and used in accordance with these instructions, may cause interference to radio communications.

Electromagnetic interference (EMI) considerations

The drive(s) described herein, as delivered, are designed for system integration and installation into a suitable enclosure prior to use. As such, the drive(s) described herein are supplied as a sub-assembly and are not subject to Subpart J of Part 15 of the FCC Rules

and Regulations nor the Radio Interference Regulations of the Canadian Department of Communications. However, the unit has been tested using proper shielding and grounding and found to be compliant with the Class A limits of the FCC Rules and the Regulations of the Canadian Department of Communications.

The physical design characteristics of the drive(s) described herein, serve to minimize EMI radiation when installed in an enclosure that provides reasonable shielding. As such, the drive(s) are capable of meeting the Class B limits of the FCC Rules and the Regulations of the Canadian Department of Communications.

Note. It is the end users' responsibility to assure that the drive(s) described herein meet the appropriate EMI requirements of their system. Shielded I/O cables may be required if the enclosure does not provide adequate shielding. If I/O cables are external to the enclosure, shielded cables should be used, with the shields grounded to the enclosure and to the host controller.

Before you begin

Verify that the system is switched off and disconnected from main power before any installation is attempted.

Protect yourself, the drive, and your valuable programs and data by reading the following cautions and warnings.

- Do not tamper with sealed top cover. Doing so voids your warranty. The drive contains no user serviceable components. See Product Repair section for more information.
- Visually inspect the shipping container for any obvious damage.
- Verify all parts listed on shipping bill are received with the equipment. Discrepancies or damage should be reported to the shipping company.
- Inspect drive for possible shipping damage. All claims of this type should be filed promptly with the transporter involved. Save original packing materials to be used when reshipping.

- When transporting or shipping a drive or system, please ensure that they are correctly packed in original Seagate approved (or equivalent) container and shipped via an air-ride carrier experienced in handling computer equipment.
- Do not unpack drive from its static shielded bag until you are ready to install it in the system.
- Always handle the drive by the frame or casting.
- Do not touch Printed Circuit Board (PCB) or the I/O connector pins.
- Never apply pressure to the PCB or to the drive top cover

Caution. The circuit assemblies and components contained in this equipment can be degraded or destroyed by Electrostatic Overstress (EOS) or by Electrostatic Discharge (ESD).

Static electrical charges can accumulate quickly on personnel, clothing and synthetic materials. The electrostatic fields due to these charges when brought in close proximity to susceptible circuit assemblies and components, can result in degraded reliability or immediate failure of the affected component or assembly.

To insure optimum reliable equipment operation, it is required that technical support personnel discharge themselves by wearing a grounding strap around the wrist and be connected to a grounding terminal while working in the vicinity of, and while handling EOS/ESD susceptible assemblies/parts. If unavailable, ground yourself frequently by touching the metal chassis of the system before handling any components (this helps only if the system is connected to a ground). *Avoid static-inducing carpeted areas.* This procedure is especially important when handling printed circuit boards (PCB's).

Safety instructions

1. The disc drive(s) are to be installed in a customer supplied enclosure where the surrounding air does not exceed 50°C.
2. Four (4) 6-32 UNC-2A screws are required for installation. Maximum screw length into side of drive is 0.15 inches (3.81 mm). Maximum screw length into bottom is 0.20 in. (5.08 mm). Screw tightening torques is 6.0 lb-in (.675 NM) max with minimum thread engagement of 0.12 in (3.00 mm).
3. The power requirements are shown in the Product Information section.
4. The power supply must satisfy the safety requirements for SELV (Safety Extra Low Voltage) circuits.
5. Service is to be provided by trained Seagate service personnel.
6. The incorporation of the disc drives listed in this guide into a customer enclosure must meet the appropriate safety requirements of the country in which it is used (e.g. UL 1950, CAN/CSA-C22.2 No. 950-M89, DIN VDE 0805:1993 and EN60950:1992 (IEC 950).

Note

Power must be off when connecting or disconnecting.

Sicherheitsanleitung

1. Das Gerät ist ein Einbaugerät, vorgesehen für eine maximale Umgebungstemperatur von 50°C.
2. Zur Befestigung der Drive werden 4 Schrauben benötigt (6-32 UNC-2A). Die maximale Länge der Schrauben in der unteren Seite des Chassis darf nicht mehr als 0.20 in (5.08 mm) betragen, die in der Seiten 0.15 in (3.81 mm). Maximale Schraubenanziehung von 6.0 in-lb (.675 NM) mit minimalem Gewindeanspruch .12 in (3.00 mm).
3. Die Versorgungsspannungen werden in der Sektion Produkt Information gezeigt.
4. Die Versorgungsspannung muss SELV entsprechen.
5. Alle Arbeiten dürfen nur von ausgebildetem Seagate Service-Personal durchgeführt werden.
6. Der Einbau des Drives muss den Anforderungen gemäss DIN VDE 0805:1993 oder EN60950:1992 (IEC 950).

Vorsicht

Änschluss oder Entfernung oler Geräteverbindung nur bei abgeschalteter Versorgungsspannung vornehmen.

Installation Overview

Installation of the drive can be divided into distinct phases. Some of these may not be applicable to all system installation requirements. Refer to the individual drive installation sections for specific information on your drive model.

- **Drive configuration:** Select those drive features that are appropriate to install the drive in the system. This is done by installing or removing user configuration jumpers found on the drive PCB.
- **Mechanical installation:** After setting up the drive configuration the drive must be mechanically installed into the host system and the power and I/O cables attached. Previously mentioned precautions should be observed.
- **CMOS configuration:** SCSI drives should not be defined in the CMOS. The SCSI host adapter uses its own BIOS to handle the Input/Output procedures. The CMOS setting for SCSI drive is either drive type zero, or the no drive installed option.

- **Low-Level formatting:** All Hawk 2LP family drive models are low-level formatted at the factory and do not require this step during installation. If an installed drive is low-level formatted, all user data will be lost.

Note: Seagate Technology assumes no liability for lost user data.

- **Partitioning and high level formatting:** A drive can be sub-divided into "partitions" which behave as individual drives within the system. Consult the system documentation for instructions on partitioning and high level formatting. Information is also available in bookstores and libraries.

Product repair information

Service requirements

The special facilities required for the manufacture of these drives generally prohibit repair in the field. If problems occur during installation, please contact your supplier for assistance. Do not attempt to disassemble or repair. Drives should be sent to the repair depot through the purchase source, if possible. Please observe the following cautions.

Caution.

- Handle drive with care. Do not drop, or bump hard.
- **Never** remove the cover of these disc drives. Servicing items in the sealed HDA (heads, media, actuator, etc.) require special facilities. The drive contains no user purchasable parts or PCBs.
- Opening the sealed HDA voids the drive warranty.
- Applying a soldering device to the components on the PCB voids the drive warranty.
- Do not connect or disconnect cables without first removing power from the drive.

- Place drive on a flat, static dissipative surface and handle with extreme care. Always follow all EOS/ESD precautions to avoid damage to the electrical assemblies.

Shipping: When transporting or shipping a drive, a Seagate approved container must be used. Keep your original box. They are easily identified by the Seagate Approved Package label. Shipping a drive in a non-approved container voids the drive warranty.

Seagate repair centers may refuse receipt of components improperly packaged or obviously damaged in transit. Contact your Authorized Seagate Distributor to purchase additional boxes. Seagate recommends shipping by an air-ride carrier experienced in handling computer equipment.

Product repair and return information

Seagate customer service centers are the only facilities authorized to service Seagate drives. Seagate does not sanction any third-party repair facilities. Any unauthorized repair or tampering with the factory-seal voids the warranty.

Warranty: Contact your Seagate Authorized Distributor, Dealer or other purchase source for warranty information.

If the drive is no longer under warranty contact purchase source for repair information or refer to numbers listed in section Technical Support Services.

Technical support services

Seagate Technology provides technical support literature and diagnostic utilities to Authorized Distributors. Please contact your dealer for technical support and installation troubleshooting. Product Technical Support is available for all Seagate products by calling the SeaFAX, SeaFONE, SeaTDD or SeaBOARD services. These are toll calls.

SeaFAX number : 408/438-2620

You can use a Touch-Tone telephone to access Seagate's automated FAX delivery system and select technical support information by return FAX. This service is available 24 hours a day, 7 days a week.

SeaFONE telephone number: 408/438-8222

The enhanced phone system provides recorded technical information on selected Seagate products while you are on hold. Technical support specialists are available to answer questions from 8:00 AM to 5:00PM PST, Monday through Friday. Recordings are accessible 24 hours a day, 7 days a week.

SeaTDD telephone number: 408/438-5382

TDD is a Telecommunication Device for the Deaf where two people can communicate using a keyboard that is connected to the phone line. A TDD device is required to access this service. This service is available from 8:00 AM to 5:00 PM PST, Monday through Friday.

SeaBOARD service:

The Seagate Technical Support Bulletin Board System (BBS) is available 24 hours a day, 7 days a week. A modem is required to access this service. The communications software must be set for eight data bits, no parity and one stop bit (8N1).

With this service you can access:

- Specifications and jumper configurations for all Seagate products.
- Reprints of Seagate documentation.
- A directory of information and helpful utilities that you can download to your own computer.

BBS Location	Modem Number	Maximum Baud Rate
United States	408-438-8771	9600
England	44-62-847-8011	9600
Germany	49-89-140-9331	2400
Singapore	65-227-2217	9600
Australia	61-2-756-2359	9600

Note: These are toll calls

Hawk 2LP Family product information

Characteristics of the various drives covered by this manual are listed in the following table.

Legend for table column meanings:

- A = capacity, unformatted Gigabytes
- B = capacity, formatted megabytes [1]
- C = number of cylinders, user accessible
- D = number of heads
- E = + 5 V typical current [2], Amps
- F = +12 V typical current [2], Amps

Model	A	B	C	D	E	F
ST32430N	2.59	2.14	3992	9	0.80	0.40
ST32430ND	2.59	2.14	3992	9	0.90	0.40
ST31230N	1.28	1.06	3992	5	0.80	0.40
ST31230ND	1.28	1.06	3992	5	0.90	0.40

Notes.

- [1] Standard units are factory formatted with 512 data bytes per sector with one spare sector per track and 2 cylinders at inner tracks reserved for spares in addition to capacity listed. All spare sectors are on one track.

- [2] Measured with an average reading DC ammeter. Instantaneous +12 V current peaks will exceed these values.

Initial set-up information

For the initial setup connect the cables or plug into a mounted connector (if applicable), set the drive ID on the bus and enable or disable the I/O line terminator IC ("N" models). These procedures are described in paragraphs following. Note whether drive model number ends in N or ND.

SCSI interface cable connection

Models Hawk 2LP family are SCSI interface drives. System connection is via a 50 pin SCSI connector. Pin 1 is noted in Figure 2. Some cables have a contrasting color stripe on one edge to indicate pin 1. Strain relief is recommended at the cable in drives using cables. Do not block system cooling air flow in routing of cables.

DC Power connection

The drives receive DC power through a 4 pin connector mounted on the PCB next to the SCSI I/O connector. See figure below.

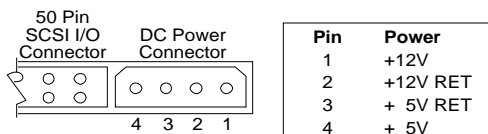

Figure 1. DC power connection, 50 pin SCSI I/O connector

SCSI address selection

Make sure that the SCSI bus address jumper(s) are properly set for the bus address assigned to the drive. See figures 3a and 3b showing the bus address select header and the jumper configurations that select addresses 0 through 7. Typically the primary boot device is set to ID 0, and the subsequent SCSI drives are jumpered in ascending order. Bus addresses 0 through 6 should be used (the host adapter usually uses address 7). If the drive LED shows no on/off activity when the host is trying to communicate with it, an incorrect bus address selection at the drive should be suspected.

Bus termination

Model "N" drives have an active terminator IC that is permanently installed, but can be enabled or disabled by a jumper plug. See jumper in Figure 3a. If you are installing a single drive, the terminator IC must remain enabled. If you are installing multiple hard disc drives, disable the termination IC on all the drives but the one connected to the end of the SCSI I/O cable.

Model numbers that end in "ND" have differential I/O circuits. These drives have no provisions for terminators on the drive PCB. The system manufacturer must provide some external means of I/O line termination. The "ND" model drives can provide power for external terminators if the **TP** jumper is installed on the last position on the right end of J2. See Figure 3a.

Read/Write head auto-park

Seagate disc drives described herein mentioned in this drive park the heads automatically at power off. This feature requires no operator intervention.

Optional parity bit enable

Some systems require parity bit checking. Consult the system documentation for the specific requirements. See Figure 3a for location of Parity Bit enable jumper. Jumper-installed enables parity reporting by the SCSI bus.

Write precompensation and reduced write current

Not required on Seagate SCSI Interface drives covered by this manual.

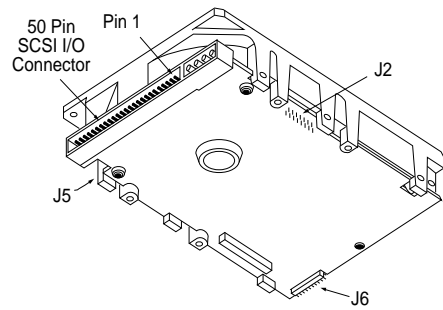

Figure 2. Hawk 2LP family N/ND model drives I/O connection (50 pin SCSI I/O connector). "N" model drive terminators (not visible) are not removable.

Drive configuration

Each disc drive has one or more option select header connectors on the back, side or front where jumper plugs are installed to select the way that the drive is to be configured or to select its ID on the I/O bus. See notes following Figure 3b.

Hawk 2LP family N/ND models (50 pin SCSI I/O)

On Model N/ND drives either J6 (on the front of the drive) or J5 (on the side behind the DC Power connector) may be used to set the drive ID. To avoid possible incorrect ID setting, do not use both J5 and J6 for ID selection. The following figures show where these headers are located on the different drives covered by this manual. See notes following Figures 3a and 3b where explanations are given about the purpose of each jumper and specify the standard factory (called "default") settings of these jumpers (i.e., settings used for most common single drive application). Changes to these settings should be made only if it is known that the system requires a different configuration.

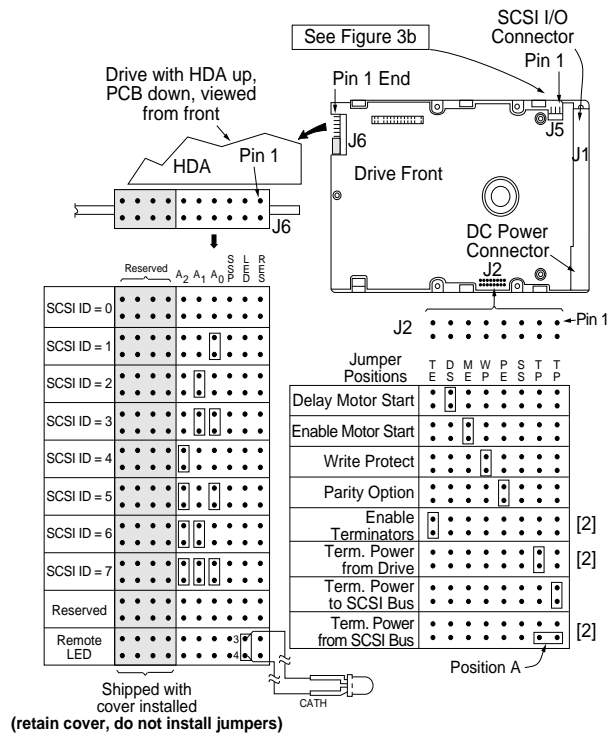

Figure 3a. Drive configurator, Hawk 2LP family N/ND models

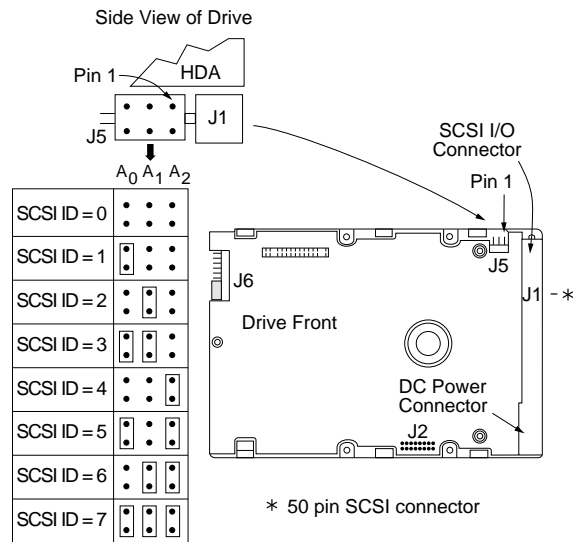

Figure 3b. Drive configurator, Hawk 2LP family N/ND models

Notes for Figure 3a and 3b:

[1] Notes explaining the functions of the various jumpers on jumper header connectors J2, J5 and J6 are given below in left to right order of jumper position. The term "**default**" means as standard OEM units are configured when shipped from factory. "Off" means no jumper is installed; "On" means a jumper is installed. Off or On underlined is factory **default** condition.

Suggested part number for the unusual J2 jumper is Molex 52747-0211 (Seagate P/N 77679052).

[2] "ND" models do not have terminators on the drive PCB, so these jumpers are not applicable.

J2 Jumper**Position Jumper Function Description****TE (Applies to "N" models only)**

<u>On</u>	With the jumper installed, the On-board (non-removable) terminator circuits are enabled (connected to the I/O lines). Default is jumper installed.
Off	Terminator circuits are disabled.

DS ME

<u>Off</u> <u>Off</u>	Spindle starts immediately after power up - Default setting.
Off On	Drive spindle does not start until Start Unit command received from host.
On Off	Spindle Startup is delayed by SCSI ID times 12 seconds after power is applied, i.e., drive 0 spindle starts immediately when DC power connected, drive 1 starts after 12 second delay, drive 2 starts after 24 second delay, etc.
On On	Drive spindle starts when Start Unit command received from host. Delayed start feature is overridden and does not apply when ME jumper is installed.

WP

On	Entire drive is write protected.
<u>Off</u>	Drive is not write protected. Default is no WP jumper installed.

J2 continued from previous page

PE

- On Parity checking and parity error reporting by the drive is enabled.
- Off Drive does not report result of parity checking to host. **Default** is a **PE** jumper installed.

SS

- Off/On Reserved. **Default** is no jumper installed.

TP TP

- Off Off No terminator power is connected to drive terminators or SCSI bus I/O pin 26.
- On Off Drive supplies its own terminator power only. Jumper on this position is factory **default** for "N" models only.
- Off On Drive supplies power to I/O pin 26 of SCSI bus; none to internal terminators. When drives have differential I/O circuits, a jumper on the right **TP** position may be needed to power external terminators (see system documentation). The "ND" model drives have differential I/O circuits which have no terminator circuits on the drive.
- On On Drive supplies terminator power to itself (internal connection) and to I/O pin 26 of SCSI bus. This is a legal jumper setting.

continued from previous page

TP Position A ("N" family models only)

- On This horizontally positioned jumper across the two **TP** positions nearest PCB edge, connects terminator power from SCSI bus I/O pin 26 to the drive's internal terminators.
- Off See above explanations for **TP** jumpers.

**J5 Jumper Jumper Function Description
Installation ("N" and "ND" models only)**

- A_0, A_1, A_2 Drive ID on SCSI Bus (J6 may be used instead). The drive ID is binary coded positionwise i.e., jumper in position A_2 is drive ID 4, in position A_1 is ID 2, position A_0 is ID 1 and no jumpers is ID 0. **Default** is ID = 0.

**J6 Jumper Jumper Function Description
Installation**

- A_2, A_1, A_0 Drive ID on SCSI bus. On "N" and "ND" models, either J5 or J6 (optional) may be used to select drive ID. Both should not be used at the same time, because at some future time when the ID is changed the user could fail to configure both J5 and J6 the same. **Default** is ID = 0.

J6 continued from previous page

LED These pins used to connect a cable for a remote LED indicator. Pin 3 (top, nearest HDA), the anode connection, connects in the drive to the +5V supply through a pull-up resistor. Pin 4 (bottom), the cathode connection connects in the drive to signal common through the emitter-collector junction of a transistor switch that controls the LED on/off condition.

Drive installation

This section describes the physical mounting of the drive in the host cabinet and the logical installation as a system member, which is called drive setup.

Disc drive mounting

Do not touch the connector pins or any PCB components without observing static-discharge precautions. Always handle the drive by the frame only.

The drive may be mounted in any orientation.

- Mount to host system chassis using four 6-32 UNC screws. Three mounting holes are in each side and four in the bottom of the drive. See Figure 6. The maximum length that the screws should extend into the side chassis mounting holes is 0.15 inch (3.81 mm), and 0.20 inch (5.1 mm) into bottom holes, measured from the outer surface of the chassis. The minimum thread engagement for all mounting screws is .12 inch (3.0 mm). Tighten the screws evenly to a maximum torque of 6 in-lb (.675 NM). Do not over tighten or force when screw does not seem to screw in easily (threads not correctly engaged).

- Verify that all connections between the drive and the host system are correctly installed. Most cables have a contrasting color stripe indicating pin 1. Pin 1 on the drive I/O connector and the DC power connector are indicated in the figures in the Initial Set-up Information section.
- Verify option select and drive ID select jumpers and installation of terminator enable jumper where applicable. See Drive Configuration section.

Do not power up the host system until the drive is mounted and the system cover is replaced.

- Connect DC power connector to the drive.
- Replace the Host System cover.
- Turn on DC power.
- Boot the system from the floppy drive or from a previously installed hard-drive if there is one.
- Proceed with drive setup of the new hard drive.

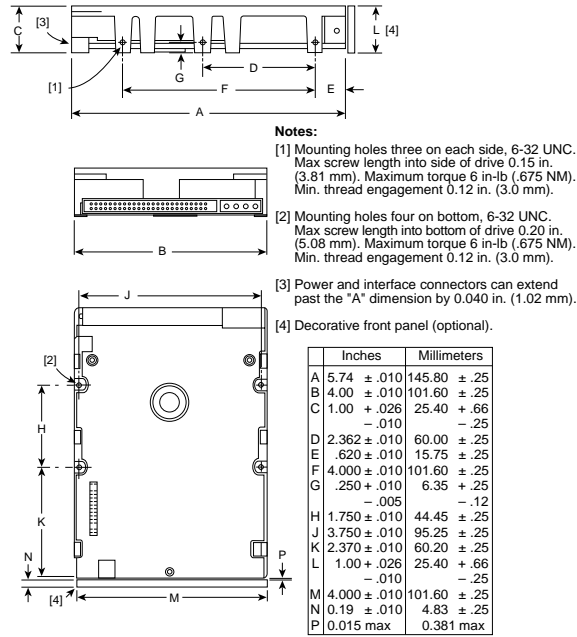

Figure 4. Hawk 2LP family N/ND model mounting dimensions (50 pin SCSI I/O connector)

Grounding

Signal ground (PCB) and HDA ground are connected together in the Hawk 2LP family drives and cannot be separated by the user. The equipment in which the drive is mounted is connected directly to the HDA and PCB with no electrically isolating shock mounts. If it is desired for the system chassis to not be connected to the HDA/PCB ground, the systems integrator or user must provide a nonconductive (electrically isolating) method of mounting the drive in the host equipment.

SCSI interface drives

The SCSI interface handles both drive geometry and defect management internally. The "no drive installed" option is selected for systems with SCSI drives.

All SCSI interface drives are low-level formatted at the factory. You may wish to low-level format the drive to optimize its performance for your system. Consult the controller documentation for information on low-level formatting. Partitioning and high-level formatting can be done through DOS by way of the FDISK utility for partitioning, and FORMAT for high-level formatting. Consult your DOS manual for FORMAT and FDISK command options.



Seagate Technology, Inc.

920 Disc Drive

Scotts Valley, CA. 95066-4544, USA

Publication Number: 77767473, Rev. B

Printed in USA