

# **TEAM<sup>®</sup> V.34/Dual**

**for HP OpenView/UNIX, Version 3.0.0  
Operation Manual**

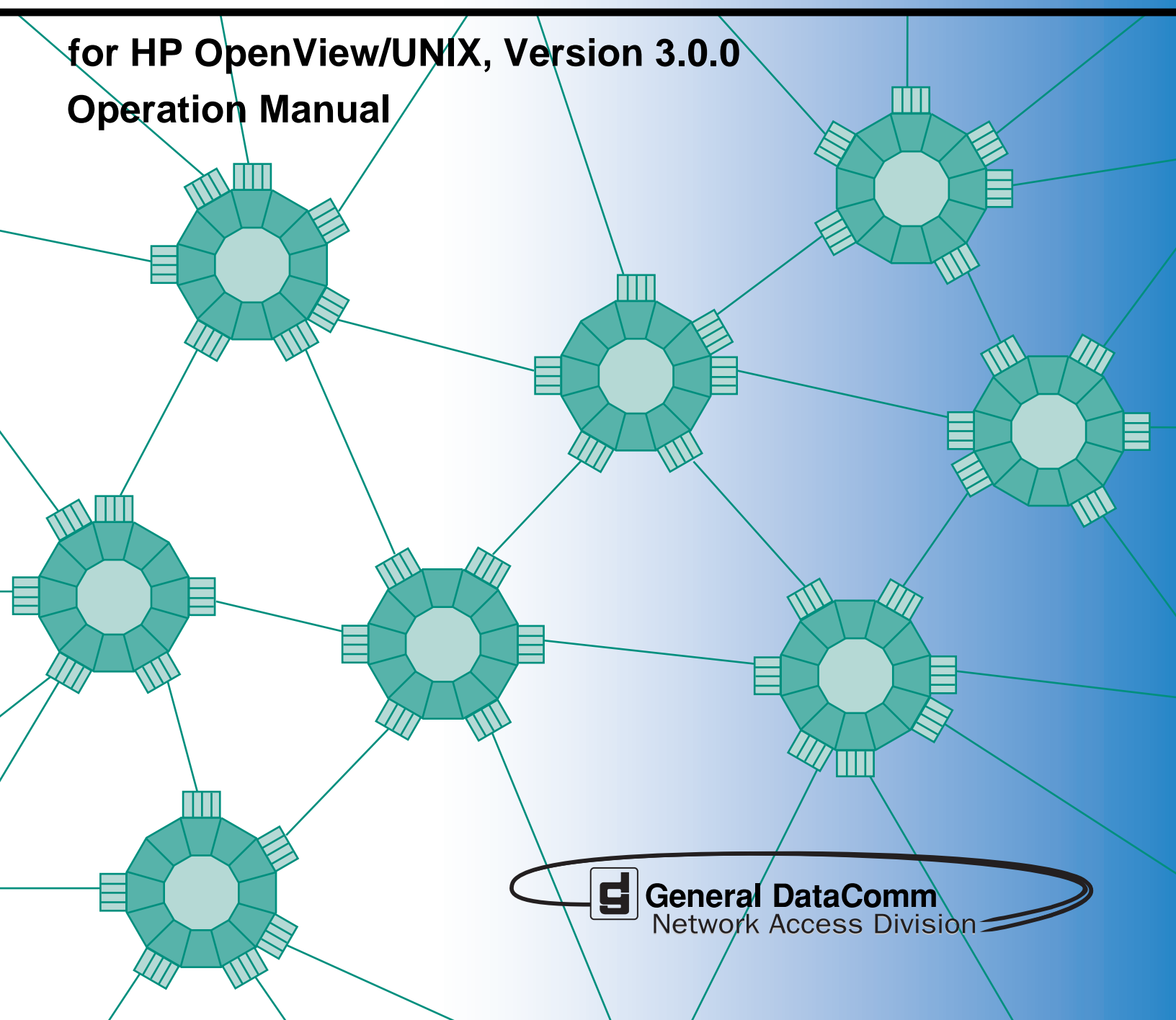



058R716-V300  
Issue 1  
September 1999

# ***TEAM<sup>®</sup> V.34/Dual***

**for HP OpenView/UNIX, Version 3.0.0  
Operation Manual**

## Copyright

©1999 General DataComm, Inc. ALL RIGHTS RESERVED.

This publication and the software it describes contain proprietary and confidential information. No part of this document may be copied, photocopied, reproduced, translated or reduced to any electronic or machine-readable format without prior written permission of General DataComm, Inc. The information in this document is subject to change without notice. General DataComm assumes no responsibility for any damages arising from the use of this document, including but not limited to, lost revenue, lost data, claims by third parties, or other damages.

If you have comments or suggestions concerning this manual, please contact:

General DataComm, Inc.  
Network Access Division  
Technical Publications Department  
Park Road Extension  
Middlebury, Connecticut USA 06762-1299

Telephone: 1 203 758 1811

## Trademarks

All brand or product names are trademarks or registered trademarks of their respective companies or organizations.

## Documentation

### Revision History

Issue Number	Date	Description of Change
1	September 1999	Initial Issue

### Related Publications

A listing of related user manuals is provided below. In addition to the hardware and software manuals, always read the software System Release Notes supplied with your product.

Publication Name	Publication Number*

\* For publications numbers, **REV** is the hardware manual revision (for example, -000, -001, etc.) **VREF** (if listed) is the software revision (for example, -V120 would read, Version 1.2) and corresponds to the most current revision.

# Table of Contents

## **Preface**

<a href="#">Scope</a> .....	v
<a href="#">Manual Organization</a> .....	v
<a href="#">Service Support and Training</a> .....	vi

## **Chapter 1: Introduction to TEAM V.34/Dual**

<a href="#">Dual V.34 Modem</a> .....	1-1
<a href="#">TEAM V.34/Dual Applications</a> .....	1-2
<a href="#">Theory of Operation</a> .....	1-3
<a href="#">Map Window Menu Bar Access</a> .....	1-3
<a href="#">Modem Front Panel</a> .....	1-4
<a href="#">Common Window Features</a> .....	1-8

## **Chapter 2: Operation**

<a href="#">Performance Functions</a> .....	2-1
<a href="#">Alarm Application</a> .....	2-1
<a href="#">Call Statistics Application</a> .....	2-3
<a href="#">Modem State Application</a> .....	2-5
<a href="#">Reports Application</a> .....	2-6
<a href="#">Report Filters Window</a> .....	2-8
<a href="#">Call Statistics Data Storage</a> .....	2-9
<a href="#">Configuration Functions</a> .....	2-10
<a href="#">Configuration</a> .....	2-10
<a href="#">Maintenance Application</a> .....	2-11
<a href="#">Diagnostics/Dial Application</a> .....	2-11
<a href="#">Miscellaneous Functions</a> .....	2-11
<a href="#">Information</a> .....	2-11
<a href="#">Front Panel Poll Rate</a> .....	2-12
<a href="#">Note Pad</a> .....	2-12

## **Chapter 3: Configuration**

<a href="#">Starting the Configuration Application</a> .....	3-1
<a href="#">User Profiles and Templates</a> .....	3-1
<a href="#">Main Configuration Functions</a> .....	3-3
<a href="#">Main Configuration Window Read-Only Display</a> .....	3-3
<a href="#">Main Configuration Window Menus</a> .....	3-4

## Table of Contents

<a href="#">Configuring a Local Dual V.34 Modem</a> .....	3-5
<a href="#">Configuring a Remote V.34 Modem</a> .....	3-6
<a href="#">General Configuration Options</a> .....	3-8
<a href="#">Terminal Options</a> .....	3-12
<a href="#">Protocol Options</a> .....	3-17
<a href="#">Dialer Options</a> .....	3-21
<a href="#">Telephone Numbers</a> .....	3-23
<a href="#">Alarms Reported</a> .....	3-24
<a href="#">Buttons and Option Selection</a> .....	3-25
<a href="#">Alarm Thresholds</a> .....	3-25
<a href="#">Network Options</a> .....	3-25
<a href="#">Private Line Options</a> .....	3-27
<a href="#">Password Options</a> .....	3-28

## **Chapter 4: Maintenance/Diagnostics**

<a href="#">Stating the Maintenance Application</a> .....	4-1
<a href="#">Maintenance Window Edit Menu Items</a> .....	4-2
<a href="#">Diagnostics/Dial Window</a> .....	4-3
<a href="#">Menus</a> .....	4-4
<a href="#">Dial/Terminate Call</a> .....	4-4
<a href="#">Dial/Terminate Procedure</a> .....	4-4
<a href="#">Diagnostic Test</a> .....	4-5
<a href="#">Diagnostic Test Procedure</a> .....	4-5
<a href="#">Diagnostics Table</a> .....	4-6
<a href="#">Analoop</a> .....	4-6
<a href="#">Analoop with Self Test</a> .....	4-7
<a href="#">Remote Digital Loop</a> .....	4-7
<a href="#">Remote Digital Loop with Self-Test</a> .....	4-8
<a href="#">Digital Loop</a> .....	4-9
<a href="#">Self-Test</a> .....	4-9
<a href="#">Diagnostics History</a> .....	4-10

# Preface

---

## Scope

This manual describes the operation of the TEAM V.34/Dual software application. The information contained in this manual has been carefully checked and is believed to be entirely reliable. However, as General DataComm improves the reliability, function, and design of their products, it is possible that information may not be current. Contact General DataComm if you require updated information for this or other General DataComm products.

General DataComm, Inc.  
Network Access Division  
Technical Publications Department  
Park Road Extension  
Middlebury, Connecticut, USA 06762-1299  
Tel: 1 203 758 1811      Toll Free: 1 800 794 8246

## Manual Organization

This manual is divided into the following chapters:

[Chapter 1, Introduction to TEAM V.34/Dual](#)

[Chapter 2, Operation](#)

[Chapter 3, Configuration](#)

[Chapter 4, Maintenance/Diagnostics](#)

This manual should be read in its entirety and all procedures completely understood before installing or operating the unit. The notes that appear throughout this manual must be read prior to any installation or operating procedure. Examples of notes used in this manual are shown below.

---

**Note**      *Indicates a note. It is something you should be particularly aware of; something not readily apparent. A note is typically used as a suggestion.*

---

---

**Important**      *Indicates an emphasized note. It is something you should be particularly aware of; something not readily apparent. Important is typically used to prevent equipment damage.*

---

## Service Support and Training

**VITAL Network Services**, a General DataComm company, is committed to providing the service support and training needed to install, manage, and maintain your GDC equipment. VITAL Network Services provides hands-on training courses through **VITAL Network Services Global Technology Training Services**. Courses range from basic data communications, modems and multiplexers, to complex network and ATM systems. Training courses are available at our centers in the US, UK, France, Singapore and Mexico, as well as at a customer's site.

For more information VITAL Network Services or for technical support assistance, contact VITAL Network Services at:

**VITAL Network Services World Headquarters**

6 Rubber Avenue  
 Naugatuck, Connecticut 06770 USA

Telephones:	Faxes:
1 800 243 1030	1 203 723 5012
1 888 248 4825	1 203 729 7611
1 203 729 2461	

<http://www.vitalnetsvc.com>

<b>VITAL Network Services Regional Sales and Service Offices:</b>	
<p><b>North American Region Office</b>                      6 Rubber Avenue                      Naugatuck, Connecticut 06770 USA                      Telephones:   1 800 243 1030                                        1 888 248 4825                                        1 203 729 2461                                        1 800 361 2552 (French Canadian)                      Training:       1 203 729 2461                      Faxes:           1 203 723 5012                                        1 203 729 7611</p>	<p><b>Central America, Latin America</b>                      VITAL Network Services                      Periferico Sur 4225, Desp. 306                      C.P. 14210, Mexico D.F., Mexico                        Telephone:       52 5 645 2238                      Training:         52 5 645 2238                      Fax:               52 5 645 5976</p>
<p><b>Europe, Middle East, Africa</b>                      VITAL Network Services                      Molly Millars Close                      Molly Millars Lane                      Wokingham, Berkshire RG41 2QF UK                        Telephone:       44 1189 657200                      Training:         44 1189 657240                      Fax:               44 1189 657279</p>	<p><b>Asia Pacific</b>                      VITAL Network Services                      501 Orchard Road 05-05                      Wheelock Place, Singapore 238880                        Telephone:       65 735 2123                      Training:         65 735 2123                      Fax:               65 735 6889</p>



# Chapter 1: Introduction to TEAM V.34/Dual

---

## System Overview

This manual covers the General DataComm TEAM V.34/Dual Unix Application for HP OpenView. You should be familiar with HP OpenView and with the operation of modems in order to use this manual effectively.

The TEAM V.34/Dual Unix Application, which runs on either a Sun workstation or an HP platform, is actually a collection of integrated applications for the HP OpenView Network Management Platform. The applications use the Simple Network Management Protocol (SNMP) to manage GDC Dual V.34 modems installed in a SpectraComm shelf.

TEAM V.34/Dual applications enable you to

- **Configure** Dual V.34 modems and perform remote configuration on GDC V.34 modems that are connected to them as remote modems.
- **Monitor** the operation of the modems through displays of Alarms, Call Statistics and Modem State, and through a Front Panel display that shows LED indicators as they appear on the front panel of the physical unit.
- **Diagnose** suspected problems using local and remote loops (with or without Self Test) and end-to-end Self Test. The dialing function is incorporated in the diagnostic application to facilitate connections for remote loops and end-to-end tests.

## Dual V.34 Modem

The General DataComm Dual V.34 modem is in fact a pair of modems built onto one pc card for installation in a SpectraComm Shelf. The two are designated Modem A and Modem B, and they function completely independent of each other. Each modem complies with the ITU-T V.34 standard, and can support connection rates to a remote modem ranging from 300 bps to 28.8 kbps. Operation at 300 bps is asynchronous; from 1200 bps to 33.6 kbps operation can be either asynchronous or synchronous. Through the use of compression, it can support DTE data rates up to 128 kbps.

The TEAM V.34/Dual manager application communicates with the Dual V.34 modem by means of a SpectraComm Manager (SCM) card installed in the shelf with the modem.

## TEAM V.34/Dual Applications

TEAM V.34/Dual application menus are available in three ways:

- From the menu bar of the Shelf Map window when a Dual V.34 modem is selected in the window, select Front Panel
- Double-click on the shelf icon.
- From the Select button on the Dual V.34 Front Panel display, click to open an application menu.

The Front Panel application displays current status information on the Dual V.34 modem by displaying the state of the LED indicators on the front panel of the unit. A Select button menu allows you to invoke all other functions of the TEAM V.34/Dual manager. The applications that make up the TEAM V.34/Dual manager are grouped on menus under the headings Performance, Configuration, Fault, and Misc (Miscellaneous):

### Performance Menu provides

- Alarms – furnishes detailed information about alarm state changes.
- Modem State – displays information on the current status of modem operations.
- Call Statistics – displays statistics concerning the current or (if there is not an active connection) most recently completed call.
- Reports – displays accumulated call statistics.

### Configuration Menu provides

- Configure – configures Dual V.34 modems and to perform remote configuration on V.34 modems connected to them.
- Maintenance – sets device-specific attributes that are not set as configuration options.

### Fault Menu allows you to:

- run diagnostic tests on Dual V.34 modems
- perform dial functions for the modem.

### Misc Menu provides:

- Information – displays revision level of the operating firmware of the Dual V.34 modem.

### Misc Menu in the Map window menu bar:

- Front Panel Poll Rate – enables you to set a default polling interval to be in effect each time the Front Panel display is opened.
- Note Pad – opens a shell tool on the workstation running the TEAM software. You can use the shell tool to run a text editor, mail tool, or any other software that resides on the workstation. The Note Pad application provides this access for keeping records on the system.

### Application Access options

From the map window, Performance, Configuration, and Fault menus contain A and B selections for each function. In the Select button menus on the Front Panel display, the selection between Modem A and Modem B is at the top of the menu structure followed by separate Performance, Configuration, and Fault menus for each modem.

## Theory of Operation

The TEAM V.34/Dual controller application consists of a group of smaller applications, each devoted to a specific aspect of controlling or monitoring the Dual V.34 modem. There are two means of access to the TEAM V.34/Dual applications: the Map window menu bar, and the Front Panel window Select button menus. This chapter describes both.

The menu group four applications in the Performance category: Alarm Detail, Reports, Call Statistics, and Modem State each display information in read-only windows to let you keep track of modem activities and operating conditions. The Reports application also enables you to save or delete selected records. This chapter fully describes those four applications.

There are two applications in the Configuration category: Configure and Maintenance each support read/write windows by which you can review and alter modem operating parameters. This chapter describes how to access the Configure and Maintenance applications. Instructions for using the two applications appear in *Chapters 3 and 4*.

The Diagnostics/Dialing application supports a read/write window by which you can command the test functions of the modem and view test results. The Dialing function is incorporated in the window to facilitate tests that require connection to a remote modem. This chapter describes how to access the Diagnostics/Dialing application. Instructions for using the application appear in *Chapter 5*.

Three items appear on the Shelf Map menu bar as Misc (miscellaneous): Information, which displays version and copyright information on the application software; Front Panel Poll Rate, which affects the Front Panel display; and Note Pad. This chapter describes all three. Of these three items, only Information appears in the Front Panel Select button menu. It can also be accessed from the Front Panel by clicking the mouse on the GDC logo in that display.

## Map Window Menu Bar Access

The table on the following page illustrates how TEAM V.34/Dual application functions are arranged on the menu bar at the top of the Shelf Map window. The table shows menu selections for both the TEAM Dual V.34 and the TEAM V.34 applications. Map window menus include selections in addition to those that apply to the TEAM products because the window also provides access to other applications.

You must select the modem you intend to work with before you open the menu you intend to use. Select a Dual V.34 modem or a V.F 28.8 modem by clicking the mouse on its icon in the shelf map.

Menu Bar - TEAM Dual V.34	Menu Selections
Performance	Front Panel... Alarms A... Alarms B... Reports... Modem State A... Modem State B... Call Statistics A... Call Statistics B...
Configuration	Configure Modem A... Configure Modem B... Maintenance A... Maintenance B...
Fault	Diagnose A... Diagnose B...
Misc	Information... Front Panel Poll Rate... Note Pad

Menu Bar - TEAM V.34	Menu Selections
Performance	Front Panel... Alarm Detail... Reports... Modem State... Call Statistics...
Configuration	Configure... Maintenance...
Fault	Diagnose...
Misc	Information... Front Panel Poll Rate... Note Pad

The Performance menu Front Panel selection opens the Front Panel display window. It is not included in the Front Panel display Select button menus. Those menus also omit the Front Panel Poll Rate and Note Pad selections from the Misc menu. All other selections in the menus that appear above do correspond to selections in the Front Panel window Select button menus.

## Modem Front Panel

The Front Panel display window (*See Figures 2-1 and 2-2*) provides a graphical interface to a selected modem. You can launch a Front Panel in either of two ways:

- select the unit you intend to work with in the shelf map window, then select Front Panel from the Performance menu for that window
- display the shelf sub-map that includes the unit you intend to work with, then double click the mouse on the slot icon for the unit.

The application responds by displaying a window that depicts the modem front panel, with LEDs that reflect the states of the indicators on the physical unit. Unless otherwise noted in the lists that follow, an LED appears bright green to indicate On or dark green to indicate Off. A two-headed arrow superimposed on a bright green LED indicates transitions.

The Dual V.34 Front Panel display shows the following indicators:

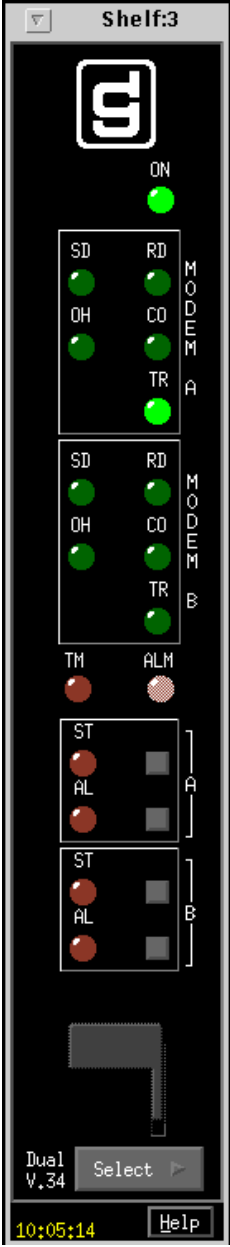
	ON	Power On
	SD	Send Data, one each for Modem A and Modem B, indicates transitions while the modem is receiving data from its DTE to transmit.
	RD	Receive Data, one each for Modem A and Modem B, indicates transitions while the modem is receiving data from the remote modem and outputting that data to its DTE.
	OH	Off Hook, one each for Modem A and Modem B
	CO	Carrier On, one each for Modem A and Modem B
	TR	Terminal Ready, one each for Modem A and Modem B, displays On, Off, or transitions
	TM	Test Mode, bright red when either modem is in a test mode, otherwise dark red
	ALM	Alarm, dark red while there are no alarm conditions in the dual modem; indicates the presence of alarm conditions by changing color and displaying A, B, or AB to indicate the modem that is currently experiencing the highest priority alarm condition (AB indicates both modems have alarms with equal priority). The LED indicates by its color the category of the current highest priority alarm: orange for major, yellow for minor, green for informational.
	ST	Self Test, one each for Modems A and B, bright red while Self Test is active on the modem, otherwise dark red
	AL	Analog Loopback, one each for Modems A and B, bright red while the modem is in the Local Loopback test condition, otherwise dark red

The V.F 28.8 Front Panel display shows the following indicators:

	TXD	Transmit Data, indicates transitions while the modem is receiving data from its DTE to transmit.
	RXD	Receive Data, indicates transitions while the modem is receiving data from the remote modem and outputting that data to its DTE.
	RTS	Request To Send
	CTS	Clear To Send
	DCD	Data Carrier Detect
	GD	Good Data
	DTR	Data Terminal Ready
	OH	Off Hook
	TM	Test Mode, bright red when the modem is in a test mode, otherwise dark red
	ALM	Alarm reflects the OpenView status of the unit, rather than the alarm status that is displayed in the Alarm Detail window. Green indicates the modem is in normal operating mode; Red indicates a critical condition (unit failure); orange indicates a major alarm condition; yellow indicates a minor alarm condition; blue indicates an informational alarm (warning) condition. The color of this indicator matches the color of the shelf submap icon for the unit.

The application polls the modem to keep the states of the LEDs in the Front Panel display current.

The bottom of a Front Panel display contains a Select button, a status field, and a Help button. The status field displays information on communications between the application and the unit. The Help button displays help information concerning the Front Panel display.

The Select button provides access to menus for the rest of the TEAM V.34/Dual application functions. The following table shows the arrangement of the Select button menus. It differs somewhat from the arrangement on the Map window menu bar.

TEAM Dual V.34 Select Button Menu	Second Level Selections	Third Level Selections
Modem A	Performance	Reports...
		Alarms...
		Modem State...
		Call Statistics...
	Configuration	Configure...
		Maintain...
	Fault...	
Modem B	<i>same as Modem A</i>	
Misc	Information...	
Demand Poll		
Auto Poll	15 seconds	
	30 seconds	
	60 seconds	
	Disable	
Exit		

TEAM V.34 Select Button Menu	Second Level Selections
Performance	Alarm Detail...
	Call Statistics...
	Modem State...
	Reports...
Configuration	Configure...
	Maintenance...
Fault	Diagnose...
Misc	Information...
Demand Poll	
Auto Poll	15 seconds
	30 seconds
	60 seconds
	Disable
Exit	

The two Poll selections in the Select button menu determine when the application collects new information from the modem to update the Front Panel window:

- Selecting Demand Poll causes an immediate update of the display.
- Auto Poll enables you to select updates at 15, 30, or 60 second intervals, or to disable automatic polling. If you select Disable the Front Panel window displays a static snapshot of the LED states as they were at the last poll, either when the window was launched or a subsequent Demand Poll.

The menu selection Exit dismisses the Front Panel window when you click on it.

## Common Window Features

Each TEAM V.34/Dual application you select opens an on-screen window in which to operate. A number of features are common to many of the windows:

Triangle button –	in the title bar; reduces the window to an icon when you click on it. Double clicking on icon restores the window. This button appears on the top level window for each application when the application is run on a Sun workstation.
Title bar –	identifies the specific TEAM V.34/Dual application running in the window; for example TEAM Dual V.34 Main Configuration, TEAM V.34 Main Configuration, TEAM Dual V.34 Diagnostics, or TEAM V.34 Diagnostics
Menu bar –	always contains the selections File, on the far left, and Help, on the far right. File menu always contains the selection Exit, by which you can dismiss the window; some window File menus contain selections special to the window. Help menu provide access to information concerning the window. Some windows have additional Menu bar selections.
	The Menu bar appears on the top level window for each application. A Menu bar appears in the Main Configuration window, for example, but not in the windows you access from Main Configuration.
Name field –	identifies the unit the application is currently connected to by displaying the user-configured shelf name, followed by the slot number, the selected modem (A or B) when working with TEAM Dual V.34, and the user-configured device name.

Descriptions in this manual of the individual TEAM V.34/Dual applications identify window features that are specific to the applications, such as selections in the Menu bar and menus, and buttons.



# Chapter 2: Operation

## Performance Functions

This section describes the performance functions which include the Alarm application, Call Statistics application, Modem State application, and the Reports application.

### Alarm Application

You can launch the Alarm application from the shelf map Performance Menu or from the front panel menu. The application displays the read-only Alarms Detail window (shown below) for the selected modem. The TEAM application gets alarm indications from the modem by receiving traps that the SCM sends in response to alarm conditions at the modem, or by polling the SCM for changes in alarm conditions at the modem. Alarm states are defined by color: Alarm Not Active - dark green; Major Alarm - orange; Minor Alarm - yellow; Informational - bright blue.



### Major Alarms

**Poor Signal Quality** – results from excessive signal-to-noise ratio on the VF Line

**Modem Cfg Checksum Error** – occurs when the checksum calculated for the modem configuration does not match the checksum value stored earlier

**DCD Loss** – occurs when there is no carrier signal being received on the line

**Call Failed** – can occur for a variety of reasons; check the Call Statistics window or the Reports window for detailed information when a Call Failed alarm occurs

**DTR Loss** – occurs when there is no Data Terminal Ready signal from the DTE

**Max Call Length Exceeded** – occurs when the duration of a call exceeds the configured call length threshold

**Retrain Count Exceeded** – occurs when the number of retrains exceeds the configured retrain count threshold

### Minor Alarms

**Ring, No Answer** – occurs when an incoming call rings but the modem does not answer.

**Fallback** – indicates that the modem has gone into fallback operation as the result of degraded line conditions.

**No TXD Transitions** – occurs when no Transmit Data transitions between polls are detected at the DTE interface; indicates possible error condition at the DTE.

**No RXD Transitions** – occurs when no Receive Data transitions between polls are detected at the DTE interface; indicates possible error condition at the remote end.

**On Dial Backup** – occurs when a modem that normally operates on a dedicated line connection has initiated a switched network connection due to problems with the dedicated line (does not appear on the TEAM Dual V.34 Alarm Detail screen).

**Remote Cfg Session Active** – occurs when the modem is in a remote configuration session, sending configuration commands to a remote modem.

**Test Timed Out** – occurs when a diagnostic test is ended automatically by the Test Time limit configured for the modem in its General configuration.

### Informational Alarm

**Power Up** – is recorded each time the Dual V.34 modem is turned On or reset

### Alarm Detail Window Menus

The Alarm Detail window menu bar has a File menu and a View menu.

- File menu contains `Exit` selection, used to dismiss the window.
- View menu provides the `Major` selection, `Minor` selection, and `Informational` selection. Click on a check to remove the associated alarm category from the display window. Click on an empty box to restore that alarm category to the display.

## Call Statistics Application

You can launch the Call Statistics application from the shelf map Performance Menu or from the front panel menu. The application displays the read-only Call Statistics window for the selected modem, as shown below.

The Call Statistics window displays statistics on the current call if the modem is connected to a remote modem when you launch the window. If there is not a current connection, the window displays the statistics of the last call that took place. A heading above the statistics display fields identifies the information as either Current or Previous. The Last Update display in the lower left corner of the window shows when the displayed statistics were collected.

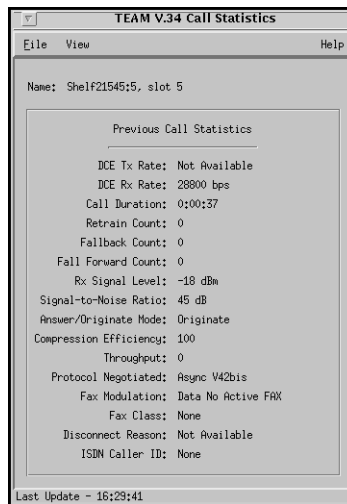

**Note** For a historical record of more than one call, use the Reports application, which is also accessed through the Performance menu.

**Table 2-1** Call Statistics Window

Selection	Descriptions
DCE Tx Rate	Displays the speed (bps) the modem transmitter connected to the remote modem.
DCE Rx Rate	Displays the speed (bps) the modem receiver connected to the remote modem.
Call Duration	Displays call duration at the time of the last poll. Up to 18 hours, 12 minutes, 15 seconds.
Retrain Count	Displays the count (0 - 127) the modem channel performed a retrain sequence during the call.
Fallback Count	Displays the count(0 - 127) the modem channel fell back to a lower connection speed during the call.
Fall Forward Count	Displays the count (0 - 127) the modem channel fell forward to a higher connection speed during the call.
RX Signal Level	0 to -48 dBm
Signal-to-Noise Ratio	0 to 40 dB
Answer/Originate Mode	Originate for call initiated by the SC 5034 DSE. Answer for call initiated by the remote modem.

**Table 2-1** Call Statistics Window (Continued)

Compression Efficiency	Percentage of data compression performed, thereby increasing transmission rate efficiency. Displays 100 when data compression is not in use.
Throughput	Number of bytes per second going to the DTE
Protocol Negotiated	Protocol used to manage the connection, determined by the DSE modem channel and the remote modem during handshake
Fax Modulation	Displays the modulation scheme used for FAX operations on the connection. Data No Active FAX, V.17, V.27, or V.29
Fax Class	Displays the class of FAX operations used during the connection (None, Class 1, or Class 2).
Disconnect Reason	Displays the reason the current call disconnected
ISDN Caller ID	This selection is not applicable for the TEAM V.34/Dual application.

### Disconnect Reason Options

- Not Applicable - Window displaying current call statistics
- User Time Out - Password not entered within required time limit
- Unknown Normal - An intentional, orderly disconnect
- Loss of Carrier
- Loss of Loop Current
- Remote Abort - Disconnect without orderly shutdown initiated by remote
- Inactivity Time Out - No transmit or receive data detected for configured DTE Inactivity interval
- Protocol Failure
- Handshake Failure - All failed during handshake process
- Password Failure - Handshake password did not verify
- Busy - Busy signal at answering modem
- No Dialtone - Originating modem did not get dialtone
- Call Establishment - Modem unable to carry out command to initiate call

### Call Statistics Window Menus

The Call Statistics window menu bar has a File menu and a View menu.

- File menu contains `Exit` selection, used to dismiss the window.
- View menu contains the `Update` selection. Select `Update` frequently to refresh the display with the latest information while viewing statistics on a current call.

## Modem State Application

You can launch the Modem State application from the shelf map Performance Menu or from the front panel menu. The application displays the read-only Modem State window for the selected modem. [Table 2-2](#) describes the states of functions performed by the selected modem.

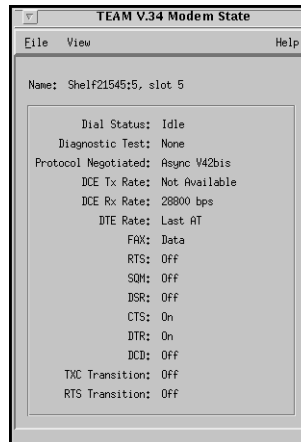

**Table 2-2** Modem State Window

Selection	Description
Dial Status	Displays dialer (not line) status: disconnect, idle, dial, training, retrain, and data.
Diagnostic Test	Displays the diagnostic test in progress.
Protocol Negotiated	Displays the on-line protocol in use by the Dual V.34 modem and the remote modem.
DCE Tx Rate	Displays the speed (bps) the modem transmitter is linked to the remote modem.
DCE Rx Rate	Displays the speed (bps) the modem receiver is linked to the remote modem.
DTE Rate	Displays the speed (bps) the modem is exchanging data with its DTE.
FAX	Displays the type of transmission currently taking place (Data or FAX).
RTS	Displays the state of the Request To Send signal at the DTE interface (On or Off).
SQM	Displays the state of the Signal Quality Monitor (On: good signal, or Off: poor/no signal. This determines the retraining or fallback/fall forward action by the modem.
DSR	Displays the state of the Data Set Ready signal at the DTE interface (On or Off).
CTS	Displays the state of the Clear To Send signal at the DTE interface (On or Off).
DTR	Displays the state of the Data Terminal Ready signal at the DTE interface (On or Off).
DCD	Displays the state of the Data carrier Detect signal at the DTE interface (On or Off).
TXC Transitions	Indicates a transition occurred in the Transmit Clock signal at the DTE interface between the most recent poll and the poll that preceded it. On indicates transitions occurring.
RTS Transitions	Indicates a transition occurred in the Request To Send signal at the DTE interface between the most recent poll and the poll that preceded it. On indicates transitions occurring.

**Note** When there is not an active connection:

- the DCE Tx Rate field displays the transmission rate of the last connection
- the DCE Rx Rate field displays the reception rate of the last connection.
- the DTE rate displays Last AT, which signifies the rate to be used at next connection.

## Modem State Window Menus

The Modem State window menu bar has a File menu and a View menu.

- File menu contains `Exit` selection, used to dismiss the window.
- View menu contains the `Update` selection. Select `Update` frequently to refresh the display with the latest information while viewing statistics on a current call.

*Note* Some of the information displayed in the Modem State window is also available from the Front Panel display. Additional modem state parameters are displayed here which are not easily represented by LEDs.

## Reports Application

You can launch the Reports application from the shelf map Performance Menu or from the front panel menu. The application displays the read-only Call Statistics Report window, shown below. This window displays the call statistics information described earlier for the Call Statistics application, together with additional information on each call. Reports stores and displays a historical record of statistics on multiple previous calls, unlike Call Statistics which displays the statistics for just one call: either the call currently taking place or the call most recently completed.

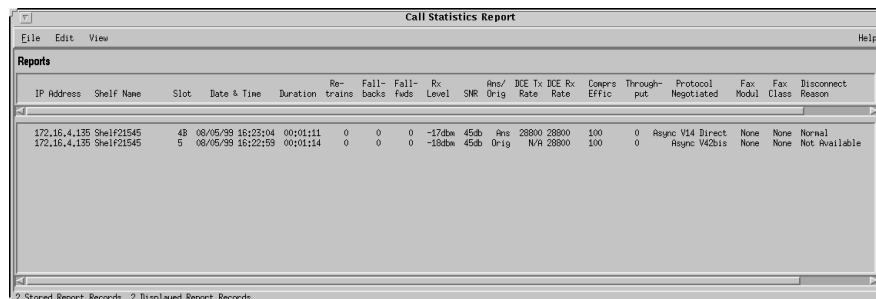

IP Address	Shelf Name	Slot	Date & Time	Duration	Re- trains	Fall- backs	Fall- fwd	Rx Level	Ans/ SHR	DCE Tx Drig	DCE Rx Rate	DCE Rx Rate	Compre Effic	Through- put	Protocol Negotiated	Fax Modul	Fax Class	Disconnect Reason
172.16.4.135	Shelf21545	4B	08/05/99 16:23:04	00:01:11	0	0	0	-17db	45db	Ans	28800	28800	100	0	Async V14 Direct	None	None	Normal
172.16.4.135	Shelf21545	5	08/05/99 16:22:59	00:01:14	0	0	0	-18db	45db	Drig	N/A	28800	100	0	Async V42bis	None	None	Not Available

2 Stored Report Records, 2 Displayed Report Records

**Figure 2-1** Call Statistics Report Window

The Call Statistics Report window displays the following items for each call:

- IP Address – of the SCM card through which the modem communicates with the TEAM V.34/Dual application
- Shelf Name – of the shelf occupied by the Dual V.34 modem
- Slot – number identifying the position of the modem in the shelf; in a statistics report for a Dual V.34 modem A and B are appended to the Slot number to identify the two individual modems
- Date & Time – at which the call was terminated.

The Call Statistics Report window appears blank until you access the View menu and specify what subset of reports you wish to view. The application can store the statistics of up to 100,000 calls, and can display up to 32,000 call statistics at a time. The Stored Report Records field in the bottom left corner of the window displays the number of records currently stored and the number of records in the current display grouping. When the 100,000 record limit is reached the application begins overwriting the earliest records.

### Call Statistics Report Window Menus

The file menu provides:

- `Save to File` selection saves call statistics records on the workstation that runs the TEAM V.34/Dual application for the purpose of record keeping or later review.
- `Exit` selection dismisses the window.

The Edit menu provides:

- `Delete All Entries` deletes entries from the Call Statistics Report to keep it current and at a manageable size.
- `Delete Displayed Entries` selection operates in conjunction with the `Set Filters` selection of the View menu.

---

**Note** *Deleted call statistics entries cannot be recovered. Perform a `Save to File` for records you will need again.*

---

The View menu controls display of information in the report window. Nothing is displayed until a selection is made from this menu. The View menu provides the following selections:

- `Today's Reports` displays all Call Statistics accumulated since midnight of the current day.
- `Yesterday's Reports` displays all Call Statistics accumulated during the previous day.
- `Report Filters` accesses the Report Filters window for specifying selection parameters to view a subset of all accumulated Call Statistics records. Refer to the following paragraphs for Report Filters window options.

## Report Filters Window

The Reports Filters window, shown below, allows you to divide accumulated records into manageable groupings for display. The options you select here determine the criteria by which stored call statistics are grouped and displayed in the Call Statistics Report window. When you click the **All Reports** selection at the top of the window, the rest of the window is grayed out and no filtering is performed. When you click the **Selected Types** selection, the filtering options described below become available. You can then click the check boxes for each individual option to set its filtering parameters as needed.

### Report Filter Options

**Received After Time/Date** specifies the earliest day, hour, and minute from which reports will be displayed. This is the start limit.

**Received Before Time/Date** specifies the day, hour, and minute beyond which reports will not be displayed. This is the end limit.

**Duration Longer than Interval** will display only statistics for calls that lasted longer than the specified duration. Use the up/down arrows to specify minimum call length in days, hours, minutes, and seconds.

**Duration Shorter than Interval** will display only statistics for calls that lasted less than the specified duration. Use the up/down arrows next to the appropriate selection fields to specify maximum call length in days, hours, minutes, and seconds.

**Call Type** will display statistics for Incoming Only or Outgoing Only. Click either check box to limit the display to statistics on incoming calls or statistics on outgoing calls.

**Shelf** will display call statistics records from a specified shelf. Click in the field and type in the name of the shelf from which you want to display statistics.

**Slot** displays call statistics records from a specified slot in a specified shelf. Use the associated up/down arrows next to the Slot Number field to select the desired slot.

**Modem** displays call statistics records for a single modem in a Dual V.34 modem. This is not a valid parameter when working with a V.F 28.8 modem. Click on the check box beside the option to select Modem A or Modem B. The default condition displays call statistics records for both modems.

**Disconnect Reason** displays call statistics records of calls that were terminated for a selected reason. Click on the check box and select the desired disconnect reason.

**Caller ID** is not applicable for the TEAM V.34/Dual application.

### Report Filters Procedure

You can activate filter options in any combination. Once selections are made, click OK to enable filter options and dismiss the Report Filters window. Otherwise, click Cancel to dismiss the Report Filters window without applying your selections.

---

**Note** The display in the Call Statistics Report window is updated based on the new filter option settings.

---



## Call Statistics Data Storage

There are three methods of recording Call Statistics information by which save statistics on demand or automatically. Once this information is saved, you can access individual files which can be copied, exported, and utilized as needed.

### Basic Record Storage

This method provides a 100,000 record storage capacity for the Call Statistics Report application and functions like a very large buffer. Once 100,000 records are stored, the application begins writing over the oldest record each time a new one needs to be created.

### Save to File Storage

This selection in the Call Statistics Report window File menu opens a pop up window in which you can specify the file name and directory path for storing the group of records currently selected for display.

### Daily File Storage

This is an automatic recording of each day's Call Statistics into a file. The data is recorded as tab-delimited ASCII text, for use in whatever database, spreadsheet, or word processing application you choose to employ. You initialize automatic Daily File storage via a configuration text file named `callstat_log.conf` stored on the workstation that runs the TEAM application.

The file contains two configurable items:

```
GenerateDailyLogFiles = YES/NO enables or disables the feature, its default condition is NO
```

```
DailyLogFileDirectory = /usr/tmp/callstats specifies the directory in which the data is stored; /usr/tmp/callstats is the default, but you can enter the path to any directory
```

Within the Log File Directory the application assigns each file it creates a six-digit name in the format `YYMMDD.log`. The first two digits are the year the file is created, the next two are the month, and the final two digits are the day.

Use the following procedure to control the Daily File feature:

1. Open a shell tool on the workstation that runs the TEAM application and sign on as the super user.
2. Launch a text editor and access the configuration file. Its full directory path and name is

```
/opt/OV/app-defaults/C/teamvf_common/callstat_log.conf
```

3. Edit the configurable items as needed. Make sure that you do not leave a space after the = sign in the input.
4. Save the editing changes and close the `callstat_log.conf` file.
5. Enter the following three commands to put the new configuration into effect

```
cd /opt/OV/bin  
./ovstop vfast_callstat_collector  
./ovstart vfast_callstat_collector
```

6. Exit from the text editor and close the shell tool.

## Configuration Functions

This section describes the configuration functions which include the Configuration application, Maintenance application, and the Diagnostics/Dial application.

### Configuration

You can launch the Configuration application from the shelf map Configuration Menu or from the front panel menu. When you launch the application, it initially displays the read-only Configuration window. The Configuration application is fully described in *Chapter 3, Configuration*.

### Configuration Window Menus

The file menu provides the following selections:

- `Refresh` discards all unsaved changes and restores all options in the displayed configuration windows to the values they are assigned by the current operating configuration
- `Save to Unit` puts the new configuration into use by the modem.
- `Load Template` recalls a stored configuration template that can be modified and saved to the modem or saved to the modem without modifications.
- `Save to Template` stores the current configuration on the workstation for future use as a template.
- `Compare to Template` identifies differences between the configuration displayed on-screen and a selected template.
- `End Remote Config Update` terminates a remote configuration session and puts any changes made into effect at the remote modem.
- `End Remote Config No Update` erminates a remote configuration session and discards any changes made rather than putting them in effect at the remote modem
- `Exit` dismisses the window.

The Navigate menu provides access to the following read/write windows where modem channel operation can be configured.

- General Options
- Terminal Options
- Protocol Options
- Dialer Options
- Telephone Numbers
- Alarms Reported
- Alarm Thresholds
- Network Options
- Password Options
- Remote Configuration

## Maintenance Application

You can launch the Maintenance application from the shelf map Configuration Menu or from the front panel menu. The application displays one read/write window by which you can control some aspects of modem operation that fall outside the scope of Configuration. The Maintenance application is fully described in *Chapter 4, Maintenance*.

## Diagnostics/Dial Application

You can launch the Diagnostics/Dial application from the shelf map Fault Menu or from the front panel menu. The application displays one read/write window by which you can control a variety of test functions on the modem. The dialing function incorporated in the window enables you to establish the switched network connection that some test procedures require. This manual fully describes the Diagnostics/Dial application in *Chapter 5, Diagnostics*.

## Miscellaneous Functions

Miscellaneous functions include the Information window, the front panel Poll rate window, and the Note Pad application.

### Information

You can launch the Information window from the shelf map Misc Menu or from the front panel menu. Information displays one read-only window that displays the name of the application, software revision level information, and copyright information.

## Front Panel Poll Rate

You can open the Front Panel Poll Rate window, shown below, from the Shelf Map Misc Menu. The setting you select in this window globally sets the initial polling rate for all Front Panel displays each time they are opened.

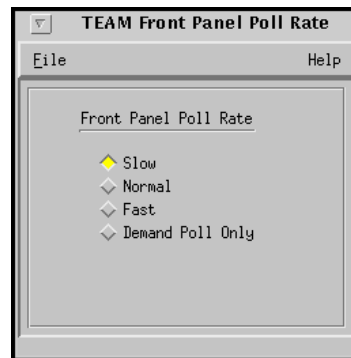

Figure 2-2 Front Panel Poll Rate Window

### Poll Rate Procedures

To set the Front Panel Poll Rate, perform the following steps:

1. Click on one of the poll rate options (Slow, Normal, Fast, or Demand Poll Only).
2. Select `Save to File` from the File menu.
3. Select `Exit` to dismiss the window. Your selection will be retained for all subsequent sessions when the Front Panel display is closed.

If you want to change the polling rate for an individual front panel display for the current session only, use the `Auto Poll` selection in the `Select` button menu. Changes you make with that menu selection are not retained when the display is closed.

---

**Note** *The precise polling frequency that results from a setting of Slow, Normal, or Fast depends on a number of factors. Generally, the higher the poll rate, the more communication and processor capacity is devoted to maintaining the display.*

---

### Front Panel Poll Rate Window Menu

The file menu provides:

- `Save to File` selection saves the poll rate on the workstation that runs the TEAM V.34/Dual application.
- `Exit` selection dismisses the window.

## Note Pad

You can launch the Note Pad application from the Shelf Map Misc Menu. The application opens a shell tool on the workstation running the TEAM software. You can use the shell tool to run a text editor, mail tool, or any other software that resides on the workstation. The Note Pad application provides this access for keeping records on the system.

# Chapter 3: Configuration

## Overview

The TEAM V.34/Dual Configuration applications enable you to set modem options through a convenient group of configuration windows. They also support remote configuration by which you can set the options in a GDC V.34 modem that is connected as a remote to the V.F 28.8 modem or Dual V.34 modem that you are controlling.

## Starting the Configuration Application

You can start the Configuration application by either of two methods:

- Select a modem symbol on the shelf submap in OpenView, then select Configure (Configure Modem A or Configure Modem B for a Dual V.34) from the Configuration menu.
- Click on the Select button of the Front Panel display, click on Configuration and select Configure from the resulting menu (for a Dual V.34, select Modem A or Modem B after clicking on Select).

## User Profiles and Templates

You do not change configuration options individually from the TEAM application. Rather, the application always loads configurations to the selected modem as a complete set, called a Profile. Each modem has four preset Factory Profiles.

You can use a Factory Profile as an operating configuration, or as a starting point for creating up to four additional User Profiles for each modem. Any change you make to a configuration option requires you to specify which User Profile (0, 1, 2, or 3) is to store the resulting configuration set. When you save a profile to a modem, it becomes the current operating configuration.

You can also use the Maintenance application to instruct the modem to use any of the eight profiles (four Factory, four User) when it is powered up and as its current operating configuration. If you want a modem to load a Factory Profile at power up, you need to save the selected Factory Profile as one of the four User Profiles.

Profiles are stored in the modem itself. You can also store configuration settings as templates on the workstation that runs the TEAM application. The filename extension “.tpl” identifies template files. You can store as many templates as you need.

## Template Procedures

To load configuration settings from a template into the modem, perform the following steps:

1. Select `Load Template` from the File menu. The Select Template window opens.
2. Select a template. The application retrieves the configuration settings of the selected template.

## Configuration

3. Select **Save to Unit** from the File menu and save the configuration as Profile 0, 1, 2, or 3. The application stores the configuration settings from the template as the designated profile and makes them the current operating configuration for the modem.

To save configuration settings as a template, perform the following steps:

1. Completing all your modifications to the configuration.
2. Select **Save to Template** from the File menu. A Select Template window appears, containing a list of existing templates and a field for entering a new template name.
3. Select an existing template to be overwritten with the new configuration, or enter a name to create a new template. A stored template is available to be loaded by the application and then saved as a profile, with or without further modification, to any DSE modem channel.

---

**Note** *Do not type the .tpl extension when entering a filename. The application appends the extension automatically.*

---

To compare the current operating configuration settings to settings stored in a template, perform the following steps:

1. Select **Compare to Template** from the File menu. The Select Template window appears.
2. Select a template from the list in the window. The application compares the configuration displayed on-screen to the settings of the selected template.
3. The application displays the differences between the two configurations, identifying each option that is set differently, the window in which it occurs, its on-screen setting, and its template setting.

## Main Configuration Functions

You can access Configuration application, either from the submap or from the Front Panel display. When accessed, the application reads the current configuration from the modem and displays a main Configuration window, shown below. Pull down menus allow you to completely configure the selected modem.

### Main Configuration Window Read-Only Display

The main Configuration window title bar displays the application name, TEAM Dual V.34 Configuration or TEAM V.34 Configuration. The read-only content area of the main window displays information which identifies the modem and provides a brief operational status, as described below.

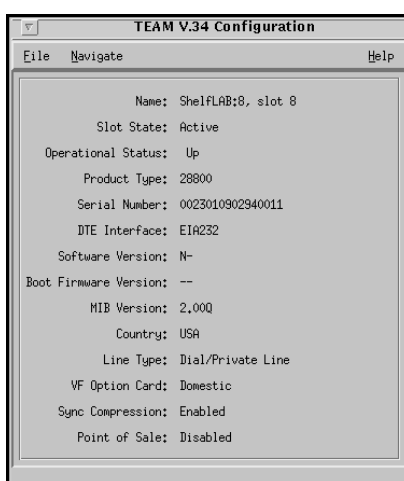

**Table 3-1** Main Configuration Window Information

Name	Displays the user-configured shelf name and the slot number of the Dual V.34 modem (A or B) selected for configuration.
Slot State	Displays Active or Inactive.
Operational Status	Displays Up (in service) or Down (out of service)
Product Type	Displays highest data rate available to the modem: 33.6, 28.8, 19.2, or 14.4 kbps
Serial Number	Displays the serial number of the modem.
DTE Interface	Displays EIA 232, EIA 530, or V.35 (TEAM V.34 only).
Software Version	Displays the revision level of the modem operating code.
Boot Firmware Version	Displays the revision level of the modem boot code.
MIB Version	Displays the revision level of the MIB file that enables SNMP control.
Country	Displays the country for which modem operation is configured. Some countries restrict certain configuration functions and values.
Line Type	Displays Dial/Private Line, Dial Only, or Dial 2-wire Private Line
VF Option Card	Displays No Card, Domestic, or Identifier for the type of VF interface daughter card installed (TEAM V.34 only)
Sync Compression:	Displays Enabled or Disabled.
Point of Sale:	Displays Enabled or Disabled.

## Main Configuration Window Menus

In the main Configuration window, the Navigate pull down menu provides the individual configuration windows where you make configuration changes. The File menu allows you to store and retrieve configuration settings in a number of ways. The contents of the two menus appear below. Note that the TEAM application uses the SCM and the modem to indicate when a configuration problem has caused an SNMP set error.

Menus	Selections	Description
File	Refresh	Reads the current configuration from the modem. Configuration changes not saved to a template or profile will be lost.
	Save to Unit	Select Profile 0, Profile 1, Profile 2, Profile 3, or Temporary Profile
	Load Template	Displays a list of available templates.
	Save to Template	Opens a dialog box for data entry.
	Compare to Template	Opens a dialog box for template selection
	End Remote Config Update	Instructs the remote modem to operate with the new configuration.
	End Remote Config No Update	With a User Profile - saves the configuration changes without updating the remote modem configuration.  With a Temporary Profile - discards all configuration and does not affect the remote modem configuration.
	Exit	Dismisses the Configuration Main menu.
Navigate	General Options Terminal Options Protocol Options Dialer Options Telephone Numbers Alarms Reported Alarm Thresholds Network Options Private Line Options Password Options	Opens associated Configuration Option windows.
	Remote Configuration	Select: Start Remote Config or Terminate Remote Config



## Configuring a Local Dual V.34 Modem

You can always make configuration changes to the current configuration or to stored configuration template without disrupting modem operation. The modem continues to operate using its unchanged current configuration.

1. To edit the current configuration of the modem, click on the **Navigate button** to display a menu of the configuration option windows, and select the one in which you intend to make changes.

To edit a template, select **Load Template** from the File menu and select a template from the resulting list.

2. Click on the input field for an option you wish to change. A window opens to display all the available parameters for that field.
3. Click on the new parameter. The option name and the new value will change from black to white type.
4. If you do not want to save the changes, restore the last stored parameters as follows:
  - Click **Refresh** to discard changes while keeping the window open
  - Click **Cancel** to discard changes and close the window.

---

**Note** You can close a configuration window without losing changes by clicking the **OK button** or the pushpin icon, located in the upper left corner of the window.

You can keep multiple configuration windows open on-screen and move between them by clicking the mouse on the one in which you intend to operate. The main Configuration window remains on-screen throughout the configuration process.

---

5. In the same manner, continue to access additional configuration option windows and make the all of the changes as needed.
6. From the main Configuration window, use the File menu to save the configuration option changes as follows:
  - Click **Save to Unit** to store the new configuration in one of four User Profiles (0, 1, 2, or 3) in the modem. The changed configuration for the modem becomes the current configuration.
  - Click **Save to Template** to save the changes in the workstation as a new template or as a change to an existing template.

---

**Note** A User Profile is only available to the modem to which it has been saved. However, you can always load a template and save it as a profile to any Dual V.34 modem, with or without further modifications.

---

## Selecting Option Values

To select from a list of values, click on the entry field for a configuration item. A window opens containing all the values that are permitted for that configuration item. Hold down the mouse button until the highlight is on the desired value, then release the button. The newly selected value appears in the entry field for the configuration item.

## Configuring a Remote V.34 Modem

The Configuration application enables you to configure a remote GDC V.34 modem that is connected to a managed (local) modem which is set up for either switched line operation or a private line connection to its remote.

### Starting a Remote Configuration Session

1. Access the main Configuration window for the local modem. You can access the window either from the submap menu or from the Front Panel display.
2. Select `Remote Configuration` from the `Navigate` menu, then select `Start Remote Config`.
  - For switched line operation, a selection window appears. Enter the desired phone number in the field, or select a number from the list of ten phone number cells stored in the modem. Then, click `Dial` to establish a Remote Configuration session. When the remote modem answers, proceed to Step 3.
  - For private line connection to the remote, the local modem will briefly break the connection and then re-establish the remote modem into a Remote Configuration session. Proceed to Step 3.
3. The application displays a submap that shows icons for the local unit and the connected remote modem. When you are working with a Dual V.34, the map shows two modems in the local unit. Click on the remote modem icon to highlight it.
4. Select `Configure` from the `Administer` menu of the submap. The application displays the main Configuration window for the remote modem.
5. Perform configuration on the remote modem just as you would on a local modem.
6. When all configuration changes for the remote modem have been made, use the remote window `File` menu and click `Save to Unit` to store the new configuration in one of four User Profiles (0, 1, 2, 3, or Temporary) in the remote modem.
  - If you select User Profile 0, 1, 2 or 3, the new configuration is stored to that profile in non-volatile memory before the remote configuration session is ended.
  - If you select the Temporary Profile, the new configuration changes are stored temporarily. The Update options described below determine whether the changes saved to the Temporary profile are saved at the remote modem or discarded.

---

**Note** *Unlike local modem configuration, the application does not update the remote modem with the new configuration at this point.*

---

7. From the File menu for the remote modem, end the session by selecting End Remote Config Update or End Remote Config No Update.
  - Select End Remote Config Update to put the new configuration into effect as the operating configuration at the remote modem.
  - Select End Remote Config No Update allow the remote modem to continue operation with the configuration it had prior to and during the Remote Configuration session.

---

**Note** *If you stored configuration changes in a User Profile, the profile remains saved. If you used a Temporary Profile, the configuration changes are discarded by the No Update option.*

---

### Terminating the Remote Configuration Session

At the end of a Remote Configuration session, the local modem and the remote modem return to the connection state they were in before the session:

- Private line operation: local and remote modem re-connect in data mode
- Switched line operation: local modem and remote modem disconnect

Note that the remote modem main Configuration window will remain open until you exit from it, as follows:

1. In the local modem Main Configuration window, select Remote Configuration from the Navigate menu.
2. Select Terminate Remote Config. The submap remains open until you dismiss it, but the remote modem icon disappears from it.

## General Configuration Options

You can access General Options from the Navigate menu. The General Options window displays, as shown below. From this window, you can control Dual V.34 modem operation criteria for Connect/Disconnect, Data Flow, Diagnostics and Power Up.

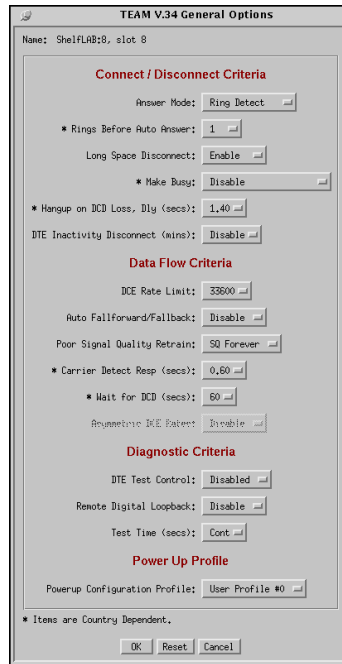

**Table 3-2** General Configuration Options

Menu	Field	Option	description
Connect/Disconnect Criteria	Answer Mode	Ring Detect	the modem handshakes in answer mode when it detects an incoming ring signal (Ring Indicator is On).
		Force Answer	the modem handshakes in answer mode regardless of whether it is answering or originating the connection.
		Originate	the modem handshakes in originate mode when it detects an incoming ring signal (Ring Indicator is On).

Table 3-2 General Configuration Options (Continued)

Connect/Disconnect Criteria (continued)	Rings Before Auto Answer	0 to 255 rings	
	Long Space Disconnect	Enable	
		Disable	
	Make Busy	Disable	the modem does not present a busy signal while on hook
		In Analoop [AL]	the modem presents a busy signal during Analoop tests
		On RTS Loss	the modem presents a busy signal when there is no RTS from its DTE
		On DTR Loss	the modem presents a busy signal when there is no DTR from its DTE
	Hangup on DCD Loss, Dly (secs)	[AL] or RTS/DTR Loss	the modem presents a busy signal during Analoop tests and when there is either no DTR or no RTS from its DTE
		0 to 25.4 seconds	
	DTE Inactivity Disconnect (mins)	None	no hangup on DCD loss
1 to 255 minutes			
Data Flow Criteria	DCE Rate Limit	Disable	no automatic disconnect for DTE inactivity
		1 to 255 minutes	
	Auto Fallforward/Fallback	Options	4800; 7200; 9600; 12000; 14400; 16800; 19200; 21600; 24000; 26400; 28800; 31200; or 33600
		Disable	modem does not perform rate negotiation during retrain
		Enable	modem performs rate negotiation during retrain
	Poor Signal Quality Retrain	Disable	the modem does not perform signal quality retrains
		SQ Three	the modem can retrain up to 3 times when attempting to achieve acceptable signal quality
		SQ Forever	the modem can retrain as many times as required to achieve acceptable signal quality
	Carrier Detect Resp (secs)	0 to 25.4 seconds	
		None	
Wait for DCD (secs)	1 to 60 seconds		
Asymmetric DCE Rates	Disable	modem transmitter and receiver always operate at the same speed	
	Enable	modem transmitter and receiver can operate at different speeds	

**Table 3-2** General Configuration Options (Continued)

Diagnostic Criteria	DTE Test Control	Disabled	modem does not perform loop tests in response to DTE interface signals
		Enabled	modem performs loop tests in response to DTE interface signals
	Remote Digital Loopback	Disable	modem ignores inband remote digital loopback commands
		Enable	modem initiates remote digital loopback in response to inband commands
	Test Time (secs)	Cont	continuous, tests run until commanded to stop
		10 to 2550 seconds	
Power Up Profile	Powerup Configuration Profile	User Profile #0	
		User Profile #1	
		User Profile #2	
		User Profile #3	

### Restrictions

Some options are marked with an asterisk (\*) to indicate that their settings may be determined or restricted by the Country Code, which is factory-configured in the modem. Depending on the country and the option, a country code restriction may specify a fixed value or it may limit the permitted range of values for an option. The modem does not accept option value changes that violate Country Code restrictions.

### General Configuration Option Definitions

**Answer Mode** - sets the mode the modem uses for handshaking in a connection that employs separate originate and answer mode frequency bands.

**Rings Before Auto Answer** - selects the number of rings the modem must receive before it performs Auto Answer. This field is Country Code dependent; the range of values shown below may be restricted by local regulations

**Long Space Disconnect** - determines whether or not the modem supports the long space disconnect function. When the function is enabled the modem reacts to a disconnect request from its DTE by transmitting 4 seconds of continuous space (BREAK) as a signal for the far end modem to disconnect. When the function is enabled the modem also accepts incoming long space disconnect signals and disconnects if it receives more than 1.5 seconds of continuous space while it is on-line.

**Make Busy** - switched-network Make Busy function options. The function specifies conditions under which the modem presents a busy signal to the telephone line despite being on hook. This field is Country Code dependent; the range of values shown below may be restricted by local regulations

**Hangup on DCD Loss, Dly (secs)** - determines how long a detected loss of carrier must persist before the modem performs a disconnect. This field is Country Code dependent; the range of values shown below may be restricted by local regulations.

**DTE Inactivity Disconnect (mins)** – determines how long a period of DTE inactivity must persist to cause the modem to perform a disconnect.

**DCE Rate Limit** – sets the maximum on-line data rate at which the modem can connect to a remote modem for the V.32, V.32 *bis*, and V.34 modulation schemes.

**Auto Fallforward/Fallback** – determines whether the modem performs rate negotiation when it does a retrain sequence because of poor signal quality. Rate negotiation can result in either an increased rate of operation (fallforward) or a decreased rate of operation (fallback).

**Poor Signal Quality Retrain** – determines whether the modem performs a retrain sequence because of poor signal quality, and how many times the process is repeated.

**Carrier Detect Resp (secs)** – determines how long the modem must detect carrier before it turns on DCD to its DTE. This field is Country Code dependent; the range of values shown below may be restricted by local regulations.

**Wait for DCD (secs)** – determines the number of seconds the modem waits for carrier detect after it completes dialing. The value displayed here is also used for the dial command modifiers W (wait for dial tone before dialing) and @ (wait for quiet answer before dialing). It also sets the time the modem waits for ringback when it originates a call. This field is Country Code dependent; the range of values shown below may be restricted by local regulations.

**Asymmetric DCE Rates** – determines whether or not the modem transmitter and receiver can connect to the remote modem at different operating speeds while operating in V.34 mode.

**DTE Test Control** – determines whether or not the DTE can command the modem to perform local and remote loop tests by asserting signals at the DTE interface (TEAM V.34 only).

**Remote Digital Loopback** – determines whether or not the modem can be commanded into a remote digital loopback test by an inband command from the far end modem.

**Test Time (secs)** – sets time limit for duration of any diagnostic test. The modem automatically terminates the test when the limit is reached.

**Powerup Configuration Profile** – selects the User Profile the modem is to use as its operating configuration upon power up or reset. When you perform Save to Unit from the Main Configuration window File menu, the setting of this option acts as a command to the modem rather than becoming part of the User Profile you specify for the save operation. Regardless of what profile it is running when power is interrupted, the modem uses the last User Profile specified either here or in the Maintenance window as its powerup profile.

## Terminal Options

The Terminal Options configuration window contains three groups of options grouped under the headings Data Mode Criteria, EIA Control Criteria, and Control Sequence Criteria. Some options are marked with an asterisk (\*) to indicate that their settings may be determined or restricted by the Country Code, which is factory-configured in the modem. Depending on the country and the option, a country code restriction may specify a fixed value or it may limit the permitted range of values for an option. The modem does not accept option value changes that violate Country Code restrictions.

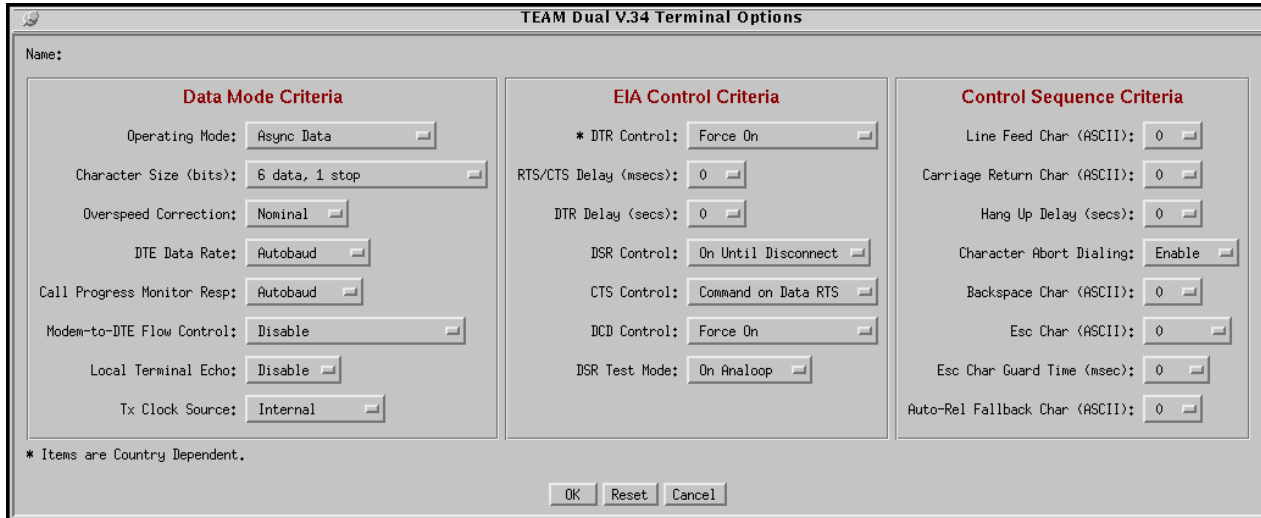

**Table 3-3** Terminal Configuration Options

Data Mode Criteria	Operating Mode	Async Data	Modem operates in asynchronous mode during both command and data modes
		Sync Data, Async Cmd	Modem operates in asynchronous mode when in command mode, and in synchronous mode when in data mode
	Character Size (bits)	Combinations of Data bits	(6, 7, or 8), Stop bits (1 or 2), and Parity type (none, even parity, space parity, odd parity, mark parity, or auto parity)
	Overspeed Correction	Extended	2.5%
		Nominal	1.25%
	DTE Data Rate	Autobaud	
		Last AT	
		300 bps to 128000 bls	Async rates
		32000 sync to 112000	Sync data rates



**Table 3-3** Terminal Configuration Options (Continued)

Data Mode Criteria (cont)	Call Progress Monitor Resp	Autobaud	
		Last AT	
		300 bps to 128000 bps	
	Call Progress Monitor Resp	Autobaud	
		Last AT	
		300 bps to 128000 bps	
	Modem-to-DTE Flow Control	Disable	No flow control
		XON/XOFF Bi- Directional Signal	Enables XON/XOFF signaling between the modem and the DTE
		CTS	Enables the modem to flow control the DTE via CTS
		RTS/CTS	Operates the same as CTS, and also allows the modem to flow control the DTE via RTS as a ready to receive signal
		XON/XOFF Uni- Directional	Enables the modem to control the DTE with XON/XOFF but ignore those signals when they are sent by the DTE
		Clock Stopping	Enables the modem to perform flow control for synchronous data compression by stopping and starting transmit clock signals
		Clock Throttling	Enables the modem to perform flow control for synchronous data compression by varying the rate of transmit clock signals
	Local Terminal Echo	Enable	
		Disable	
Tx Clock Source	Internal	Modem uses its own internally-generated clock	
	External	Modem uses the DTE clock	
	Receiver Wrap	Modem uses receiver-derived timing	
EIA Control Criteria	DTR Control	Force On	Modem ignores DTR transitions
		Off In Cmd Mode	Modem enters command mode upon detecting transition
		Off Disc	Modem disconnects upon detecting transition
		Off Disc Recall User	Modem disconnects and recalls the selected user configuration upon detecting transition
	RTS/CTS Delay	0 to 255 milliseconds	
	DTR Delay	0 to 255 seconds of delay	

**Table 3-3** Terminal Configuration Options (Continued)

EIA Control Criteria (cont)	DSR Control	On Until Disconnect	DSR On at all times, goes Off briefly to indicate disconnect
		Normal	Real DSR as specified by ITU-T
		Follow DCD	DSR On while Data Carrier Detect is On
		Force On	DSR On at all times
	CTS Control	Command on Data RTS	CTS On during command mode, CTS follows Request To Send in data mode
		Command on Data Real	CTS On during command mode, CTS operates according to ITU-T specifications in data mode
		Real ITU-T	CTS operates according to ITU-T specifications at all times
		Force On	CTS On constantly
	DCD Control	Force On	DCD On constantly
		Real	DCD operates according to ITU-T specifications
		Force on Toggle Disc	DCD On constantly, but turns Off briefly on disconnect as a signal to the front end
		On after Link	DCD forced On after connection is established
	DSR Test Mode	On Analoop	DSR On during the test
		Off Analoop	DSR Off during the test
Control Sequence Criteria	Line Feed Char (ASCII)	0 to 127	
	Carriage Return Char (ASCII)	0 to 127	
	Hang Up Delay (secs)	0 to 255 seconds	
	Character Abort Dialing	Enabled	
		Disabled	
	Backspace Char (ASCII)	0 to 127	
	Escape Char (ASCII)	0 to 127	
		Disable	
Escape Char Guard Time (msec)	0 to 5100 milliseconds		
Auto-Reliable Fallback Character	0 to 127		

**Terminal Configuration Option Definitions**

**Operating Mode** – Sets the type of data transfer in the data mode.

**Character Size (bits)**– identifies character length, format, and parity type of DTE asynchronous data.

**Overspeed Correction** – sets the tolerance of the modem for overspeed data from its DTE when operating in V.14 asynchronous data modes.

**DTE Data Rate**– selects DTE bit rate. The modem interprets this configuration item in conjunction with the handshake mode selected for the modem. The *Dual V.34 Modem Operation and Installation* manual contains more detailed information on this topic in its description of the AT command \T.

**Call Progress Monitor Resp** – selects the rate at which the modem sends Call Progress Monitor responses to the DTE when the DTE Data Rate is configured for Auto speed.

**Modem-to-DTE Flow Control**– selects the type of data mode flow control the modem employs at its DTE port.

**Local Terminal Echo** – when enabled, the modem echoes characters back to the terminal as they are transmitted.

**Tx Clock Source** – selects the source of the transmit clock for the modem.

**DTR Control** – selects how the modem responds to loss of DTR. This field is Country Code dependent; the range of values shown below may be restricted by local regulations.

**RTS/CTS Delay** – Selects the delay between RTS and CTS going on.

**DTR Delay** – Selects the delay (in seconds) between making data mode and raising DTR. It is mode-of-operation dependent. When configured for &M0, this option is used to debounce DTR. The default is .05 seconds. When configured for &M1 and in the data mode, this option sets the time available to the operator to switch the EIA cable from asynchronous to synchronous equipment. When the timer expires this option is used to debounce DTR. The default is 5 seconds.

**DSR Control** – selects how the modem controls the Data Set Ready circuit of its DTE interface.

**CTS Control** – selects how the modem controls the Clear To Send circuit of its DTE interface.

**DCD Control** – selects how the modem controls the Data Carrier Detect circuit of its DTE interface.

**DSR Test Mode** – selects how the modem controls the Data Set Ready circuit of its DTE interface during an Analoop test.

**Line Feed Char (ASCII)** – selects an ASCII character to indicate a Line Feed. This information is saved in a template but not in a User Profile. The field returns to a default of 10 when you power up or reset the modem.

**Carriage Return Char (ASCII)** – selects an ASCII character to indicate a carriage return. This information is saved in a template but not in a User Profile. The field returns to a default of 13 when you power up or reset the modem.

**Hang Up Delay (secs)** – selects how long the modem waits after detecting a command to hang up the line before it performs the disconnect operation. The default is 20.

**Character Abort Dialing** – enables character abort feature, in which any character typed at the DTE within two seconds of the modem going off-hook causes it to abort the dialing process. This feature functions only when the modem is configured to accept AT commands and is operating in asynchronous mode.

**Backspace Char (ASCII)** – selects the ASCII character to indicate a backspace. This information is saved in a template but not in a User Profile. The field returns to a default of 8 when you power up or reset the modem.

**Escape Char (ASCII)** – selects an ASCII character to indicate the ‘escape to command mode’. This information is saved in a template but not in a User Profile. The field returns to a default of 43 when you power up or reset the modem.

**Escape Char Guard Time (msec)** – selects the delay the modem uses in determining a valid escape sequence. Upon detection, it transfers from data mode to command mode. This information is saved in a template but not in a User Profile. The field returns to a default of 0.50 second when you power up or reset the modem.

**Auto-Reliable Fallback Character** – selects an ASCII character for use as the fallback character that can be employed to bypass the negotiation of an error correcting protocol. This information is saved in a template but not in a User Profile. The field returns to a default of 13 when you power up or reset the modem.

## Protocol Options

This window permits access to options that are primarily for the set up of Protocol-related issues within the modem, e.g., character handling, data compression, etc.

**Table 3-4** Protocol Configuration Options

General Protocol Options	Asynchronous Protocol	Wire	The modem runs in wire mode, performing speed buffering by copying characters from the VF to DTE port and vice versa.
		Non-speed buffered V.14	The modem runs in V.14 asynchronous Direct mode. In this mode there is no speed buffering and DTE and VF speeds must match.
		Reliable MNP	The modem runs in MNP reliable mode. If the modem cannot establish an error correcting MNP link it hangs up.
		Auto-reliable MNP	The modem runs in Autoreliable mode. The modem negotiates V.42 or alternate links. With no link, the modem enters the wire (speed buffering) mode.
		Reliable LAPM (V.42)	The modem runs in V42 reliable mode. If the modem cannot establish an error correcting V.42 (LAPM) link it hangs up.

**Table 3-4** Protocol Configuration Options (Continued)

General Protocol Options (cont)	Asynchronous Protocol (cont)	Reliable LAPM or MNP	The modem runs in reliable LAPM or MNP mode. It attempts a V.42 (LAPM) or an MNP link; if either fails, it hangs up.
		Simulated Control Carrier V.13	The modem runs in V.13 mode with simulated controlled carrier.
	Data Compression	Disabled	No compression available
		Enabled	Compression available in both directions
		TX path only	Compression available only in the transmitter path in V.42 <i>bis</i> ; compression available in both directions in MNP 5
		RX path only	Compression available only in the receiver path in V.42 <i>bis</i> ; compression available in both directions in MNP 5
	Break Character Handling	Expedite Dest	Modem immediately transmits a break character for 300 msec and erases any currently buffered data
		Expedite Non-Dest	Modem immediately transmits a break character for 300 msec, but saves all currently buffered data
		Non-Expedite Non-Dest	Modem transmits a break character for 300 msec in sequence with the rest of data.
		Ignore	Modem ignores break characters it receives from its DTE
		Timed Non-Expedite Non-Dest	Modem continues to transmit break characters in sequence with the rest of data for as long as its DTE transmits the character
		Timed Non-Expedite Non-Dest 2	Modem continues to transmit break characters in sequence with the rest of data for as long as its DTE transmits the character
	Flow Control (Wire Mode)	Inhibit	Disables flow control between the modem and its remote modem
		Enabled	Enables bidirectional flow control between the modem and its remote modem based on XON/XOFF signaling. Signals are detected, acted on, and deleted from the data stream
		Unidirectional	Provides unidirectional flow control between the modem and its remote modem. The modem can send XON/XOFF signals to the remote modem, but it ignores and passes to its DTE any flow control signals it receives from the far end
		Bidirectional	Acts the same as Enabled except that after XON/XOFF signals from the far end are acted upon, they are passed to the DTE instead of being deleted.

**Table 3-4** Protocol Configuration Options (Continued)

General Protocol Options (cont)	Synchronous Protocol	Sync Mode	Normal synchronous mode
		Sync V.13	V.13 synchronous mode
		Enable Sync Compression	Synchronous compression mode
		Sync Mode	Normal synchronous mode
	Connect Message Type	Separate Messages	The modem sends the standard GDC connect message upon reaching data mode, and sends the V.42 message after link negotiation. The connect message displays VF line speed.
		Both After Link	The modem waits until after link negotiation to send both the standard GDC connect message and the V.42 message
		Microcom Compatible	Same as Both After Link except that the modem adds /RELIABLE to the end of the message when it establishes a V.42 error-corrected link
		Connect After Link	The modem sends only the connect message after link negotiation. The message indicates the VF rate for V.13 and V.14 connections. It indicates the DTE rate for all other connections
		Connect RX & TX Asymmetric	The modem sends a connect message specifying separate receive and transmit speeds.
		Fallback & Prelink Data Buffer	No Buffer
	Buffer RX Data		The modem buffers received data (up to 200 characters) until it has sent the PROTOCOL: NONE message, then passes the buffered data to the DTE. If more than 200 characters are received before an error correction link is established, the modem falls back to wire mode
	Fallback with Fallback Char		The modem discards all incoming data until it detects two consecutive fallback characters, at which point it falls back to wire mode. the modem passes one fallback character to its DTE as data
	Fallback V14 Buffer		Same as Buffer RX Data except that when there is no link the modem falls back to V.14 (direct) mode
	Fallback V14 with Fallback Char		Same as Fallback With Fallback Char except that the modem falls back to V.14 (direct) mode

**Table 3-4** Protocol Configuration Options (Continued)

General Protocol Options (cont)	Retransmit Frame Limit	0 to 255	
	Simulated Controlled Carrier (V.13 Mode)	Bi-directional	Enables V.13 simulated controlled carrier on both the T X and the RX sides
		TX Enable	Enables V.13 simulated controlled carrier on the TX side only
		RX Enable	Enables V.13 simulated controlled carrier on the RX side only
MNP10 Protocol Options	MNP10 Mode	Disable	Modem does not operate in MNP10 Mode
		Answer	When negotiating link for an incoming call, MNP10 Mode available if requested by the remote modem
		Answer and Originate	MNP10 Mode available for incoming call; modem requests MNP10 from the remote when originating a call
	Cellular Power Level Setting	-10 dBm to -31 dBm	
	Cellular Power Level Adjustment	Disable	Unit cannot adjust transmit power level during the MNP10 link negotiation; unit can adjust power level once link is established if requested to do so by the remote
		Enable	Unit cannot adjust transmit power level during the MNP10 link negotiation; unit adjusts for optimal power level once link is established. This selection should not be used with 4800 selected as the Link Negotiation Speed.
		Fixed	Unit adjusts transmit power level during the MNP10 link negotiation, starting at the selected Cellular Power Level Setting; power level remains fixed once link is established
	Link Negotiation Speed	Highest Supported Speed	
		1200	
		4800	

### Protocol Configuration Options Definitions

**Asynchronous Protocol** – Controls protocols available at handshake.

**Data Compression** – controls how the modem performs data compression while operating in asynchronous mode

**Break Character Handling** – determines what action the modem takes when it receives a break character from its DTE

**Flow Control (Wire Mode)** – controls what type of modem-to-modem flow control the modem uses for non-error corrected links in wire mode when a constant speed DTE interface is required.

**Synchronous Protocol** – selects the type of synchronous data protocol the modem uses

**Connect Message Type** – determines when the modem is to send protocol messages to its DTE



**Fallback & Prelink Data Buffer** – determines fallback selection and how, when running an error correcting protocol, the modem handles data while it waits for establishment of the error correcting link

**Retransmit Frame Limit** – selects the maximum number of times the modem can retransmit any one frame during an error correcting connection

**Simulated Controlled Carrier (V.13 Mode)** – controls operation of the V.13 simulated controlled carrier mode

**MNP10 Mode** – determines whether or not the unit is to employ the MNP10 protocol. The following three options are grayed out when this is set to Disable

**Cellular Power Level Setting** – selects the initial level the unit is to employ for cellular transmission

**Cellular Power Level Adjustment** – determines how the unit can adjust power level during cellular transmission

**Link Negotiation Speed** – selects the speed at which the unit operates while negotiating an MNP10 connection

## Dialer Options

This window (*Figure 3-5*) sets the options for dialer operations performed by the modem.

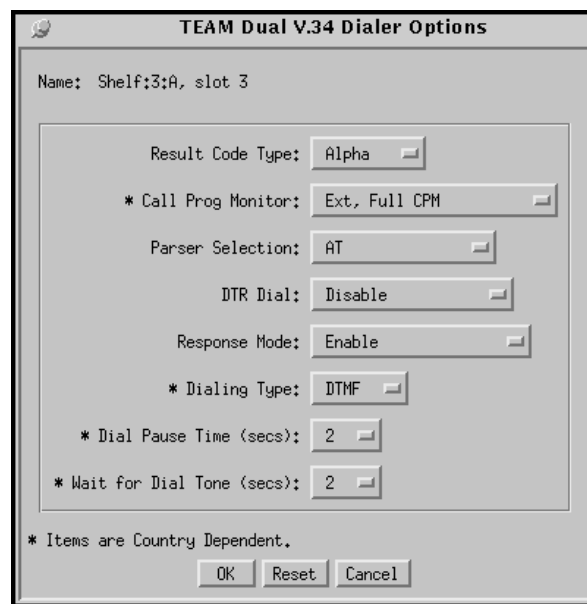

**Table 3-5** Dialer Configuration Options

Fields and Options	Result Code Type	Numeric	Modem responses are in numeric format.
		Alpha	Modem responses are in alphabetic format.
	Call Progress Monitor	Basic	Modem blind dials, and sends a CONNECT message for all established links. All CPM is disabled
		Extended No CPM	Same as Basic except that the modem also sends the connected speed following the CONNECT message
Extended Dial Tone		Same as Extended No CPM, but without blind dialing. Modem sends the NO DIALTONE message if dial tone is not detected	

**Table 3-5** Dialer Configuration Options (Continued)

Fields and Options (cont)	Call Progress Monitor (cont)	Extended Busy	Forces the modem to blind dial. All CPM responses are enabled except the NO DIALTONE message.
		Extended Full CPM	All CPM response codes and monitoring enabled except ringback detection
		Extended Full CPM Ringback	All CPM response codes and monitoring enabled, including ringback detection
	Parser Selection	AT	
		V.25 <i>bis</i> async	
		V.25 <i>bis</i> HDLC	
		V.25 <i>bis</i> Bisync	
		No parser	
	DTR Dial	Disable	Modem ignores DTR transitions
		Cell Number <i>n</i>	Modem dials number stored in cell <i>n</i> ( <i>n</i> = 0 – 9). The application prompts for the cell number
		Talk Data	Modem starts a handshake on DTR Off-to-On transition
		Continuous Call Cell Number <i>n</i>	Modem dials number stored in cell <i>n</i> ( <i>n</i> = 0 – 9) whenever DTR is high and there is not an active connection. The application prompts for the cell number
	Response Mode	Enabled	Non-quiet mode: result codes are sent to the DTE as appropriate
		Disabled	Quiet mode: no result codes are sent to the DTE
		Enable In Originate	CPM response codes enabled while modem operates in originate mode, disabled when it detects ring signal and enters answer mode
	Dialing Type	Pulse	Pulse Dial
		DTMF	Dual Tone Multi-Frequency
	Dial Pause Time	0 to 255 seconds of pause	
	Wait for Dial Tone	0 to 255 seconds	

### Dialer Configuration Option Definitions

**Result Code Type** –controls the type of responses the modem provides to its DTE when commanded to dial.

**Call Progress Monitor** – controls Call Progress Monitor operation. This field is Country Code dependent; the range of values shown below may be restricted by local regulations.

**Parser Selection** – selects the parser by which the modem recognizes dialing commands from its DTE.

**DTR Dial** – selects what the modem does when it detects an Off-to-On transition on DTR

**Response Mode** – controls when to send responses.

**Dialing Type** – Selects the type of dialing. This field is Country Code dependent; the range of values shown below may be restricted by local regulations.

**Dial Pause Time** – Selects the time (in seconds) for pause characters in the dial string. This field is Country Code dependent; the range of values shown below may be restricted by local regulations.

**Wait for Dial Tone** – Selects the time (in seconds) that the modem waits for dial tone before disconnecting. This field is Country Code dependent; the range of values shown below may be restricted by local regulations.

## Telephone Numbers

The Telephone Numbers window lets you view and modify the contents of the ten telephone number cells stored in the modem. The window displays all ten cells, each of which can hold up to 36 characters.

To modify the contents of a cell:

- Click the mouse anywhere in the input field to create an insertion point and type new input,
- or
- Click and drag to highlight and replace existing characters in the field.

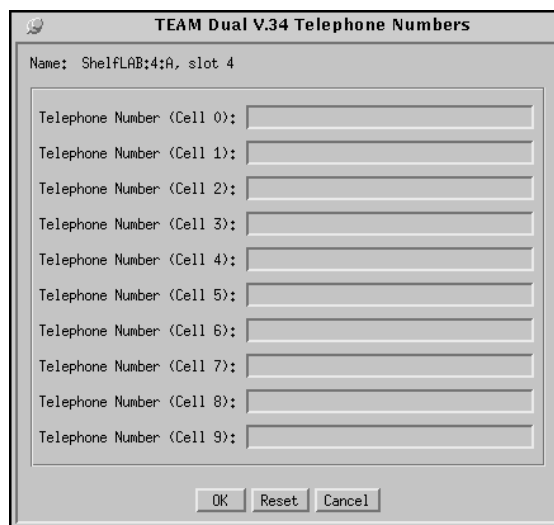

**Figure 3-1** Telephone Numbers Configuration Window

## Alarms Reported

The Alarms Reported configuration window lets you configure which alarm conditions are to be reported for the modem and which are not.

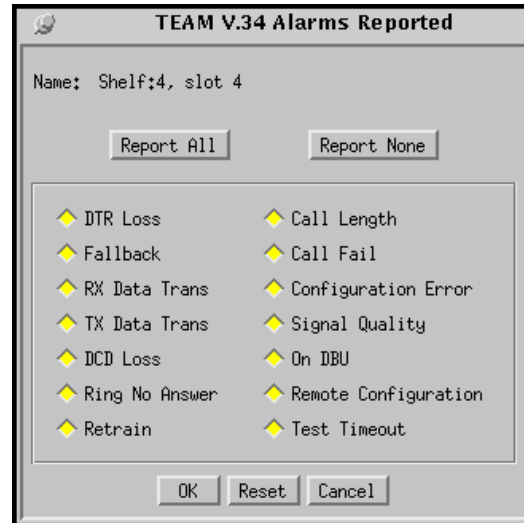

**Table 3-6** Alarms Reported Configuration Options

Report All	To highlight <u>all</u> the alarm option selection fields
Report None	To remove the highlight from <u>all</u> the alarm option selection fields
DTR Loss	Loss of DTR alarm
Fallback	Fallback alarm
Receive Data Transitions	Receive Data Transitions alarm
Transmit Data Transitions	Transmit Data Transitions alarm
DCD Loss	Loss of DCD alarm
Ring No Answer	Ring No Answer alarm
Retrain	Retrain alarm (subject to threshold)
Call Length	Call Length alarm (subject to threshold)
<i>Call Fail</i>	Call Failed alarm
<i>Configuration Error</i>	Configuration Checksum error alarm
Signal Quality	Poor Signal Quality alarm
On DBU	On Dial Backup alarm (TEAM V.34 only)
<i>Remote Configuration</i>	Remote Configuration alarm
Test Timeout	Test Timeout alarm

**Note** *The Alarms Reported configuration is stored separately from User Profile information and not saved as part of a User Profile. All four User Profiles share the same Alarms Reported configuration.*

*The Alarms Reported configuration settings in the most recently downloaded configuration determine the alarm mask for all User Profiles.*

## Buttons and Option Selection

Each of the alarm options in the Alarms Reported configuration window has a small selection field located to its left. You can select or de-select individual alarm options by simply clicking the mouse button on the appropriate selection fields. When an option is selected for its alarm to be reported, its selection field is highlighted. The selection fields next to alarm options that are not to be reported are not highlighted.

## Alarm Thresholds

The Alarm Thresholds configuration window lets you configure thresholds for the generation of Call Length and Retrain alarms.

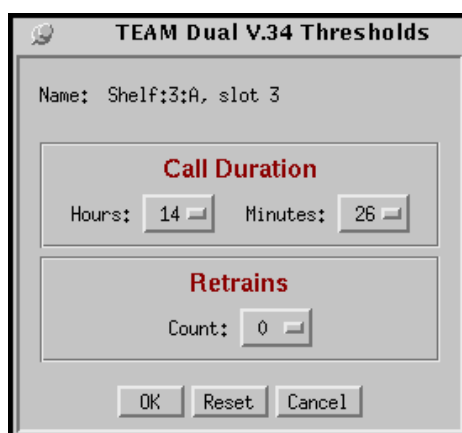

**Table 3-7** Alarm Thresholds Configuration Options

Call Duration	0 hours, 1 minute to 18 hours, 12 minutes
Retrains	1 to 25

### Alarm Thresholds Configuration Option Definitions

**Call Duration** – determines how long the modem must be continuously on-line before it generates a Call Length alarm. Two input fields are provided, one for hours and one for minutes.

**Retrains** – determines how many times the modem can go through a retraining sequence before it generates a Retrain alarm.

## Network Options

The Network Options configuration window provides access to options that are primarily for the Switched-Network/Private line selections. *Note that you can select the Switched-Network Transmit Level option only when the Switched-Network Level Type option is set for Adjustable.*

Figure 3-9 illustrates the Network Options screen for TEAM Dual V.34, which contains three options that do not appear on the TEAM V.34 version of the screen. In TEAM V.34 those three options, and others, appear on the Private Line Options screen, which is not present in TEAM Dual V.34.

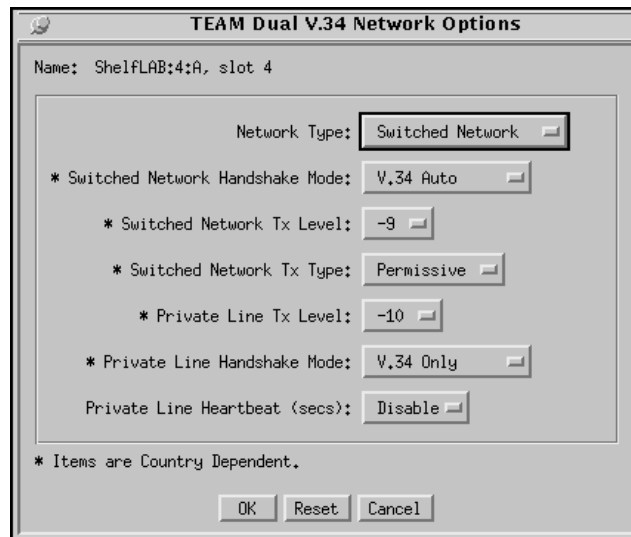

**Table 3-8** Network Configuration Window Options

Network Type	Switched-Network Private Line 2 Wire
Switched-Network Handshake Mode	V.34 Auto; V.34 Only; V.32 <i>bis</i> Auto; V.32 <i>bis</i> Only; V.32 Auto; V.32 Only; V.22 <i>bis</i> ; V.22 Only; Bell 212; Bell 103; or V.21
Switched Network Tx Level	0 to -15
Switched Network Tx Type	Permissive
Private Line Tx Level	0 to -15
Private Line Handshake Mode	V.34 Only; V.32 <i>bis</i> Only; or V.32 Only
Private Line Heartbeat	Disable 30 to 7650 seconds (assigned in 30-second increments)

**Network Configuration Window Definitions**

**Network Type** – Selects the VF line type and mode of operation.

**Switched-Network Handshake Mode** – available handshake modes. This field is Country Code dependent; the range of values shown below may be restricted by local regulations.

**Switched Network Tx Level** – shows the output signal level for switched network connections. This field is Country Code dependent; the values shown may be restricted by local regulations.

**Switched Network Tx Type** – selects the modem for compatibility with the network interface to which it is connected. This field is fixed to the Permissive setting.

**Private Line Tx Level** – selects the output signal level for a private line connection. This field is Country Code dependent; the range of values shown may be restricted by local regulations. (TEAM Dual V.34 only).

**Private Line Handshake Mode** – available handshake modes. This field is Country Code dependent; the range of values shown below may be restricted by local regulations. (TEAM Dual V.34 only).

**Private Line Heartbeat** – selects how frequently the unit is to send a “heartbeat” signal on the private line when there is no user data being transmitted or received. (TEAM Dual V.34 only).

## Private Line Options

The Private Line Options configuration window in TEAM V.34 contains options for configuring network operation when Network Type is selected as Private Line 2 Wire or Private Line 4 Wire in the Network Options window. TEAM Dual V.34 does not include this screen, but does incorporate three of its options in the Network Options screen.

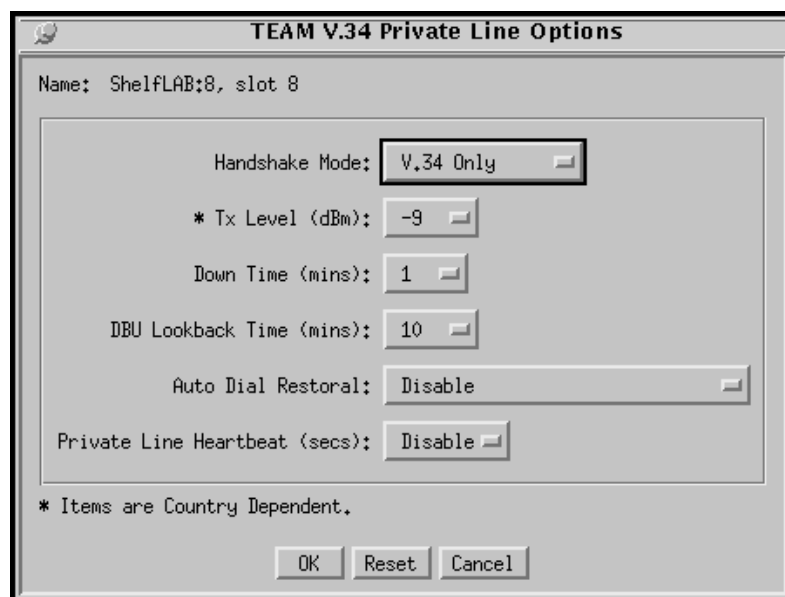

**Table 3-9** Private Line Configuration Options

Handshake Mode	V.34 Only; V.32 bis Only; or V.32 Only
Tx Level (dBm)	0 to -15
Down Time (mins)	0 to 255 minutes
DBU Lookback Time (mins)	Disable
	10 to 2550 minutes
Auto Dial Restoral	Disable
	Enable with End of Session
	Enable without End of Session
Private Line Heartbeat	Disable
	30 to 7650 seconds, assigned in 30-second increments

### Private Line Configuration Option Definitions

**Handshake Mode** – selects the handshake mode to be used on the private (dedicated) line.

**Tx Level (dBm)** – selects the output signal level for the dedicated line connection.

**Down Time (mins)** – selects how long the dedicated line must be out of service in order to cause initiation of automatic dial backup (DBU).

**DBU Lookback Time (mins)** – selects the time interval at which the modem, when operating in DBU, automatically attempts to return to dedicated line operation. The option is set in ten minute increments. When it is set to zero there is no automatic return from DBU to dedicated line operation.

**Auto Dial Restoral** – selects whether or not the modem is to perform automatic dial backup in the event of dedicated line failure. When you enable this option you must make sure that the telephone number to be used for DBU is stored in Telephone Number Cell 0 of the modem.

**Private Line Heartbeat** – selects how frequently the unit is to send a “heartbeat” signal on the private line when there is no user data being transmitted or received.

## Password Options

The Password configuration window permits you to enable or disable password protection for the modem and to specify the password to be used when protection is enabled.



**Table 3-10** Password Configuration Options

Password Operation	Enable Handshake	Enables password security in which an inband password is exchanged between the answering modem and the originating modem at the time of handshake.
	Disabled	No password security
Password	1 - 10 characters	

### Password Configuration Option Definitions

**Password Operation** – Enables or disables the Password option.

**Password** – input field for specifying the password to be used. Click the mouse on the field and type the selected password of up to ten alphanumeric characters. The characters you type in this field are not displayed on the screen.



# Chapter 4: Maintenance/Diagnostics

## Maintenance Overview

The Maintenance application provides functions for controlling the operation of a V.F 28.8 or Dual V.34 modem.

## Starting the Maintenance Application

Start the Maintenance application by either of two methods:

- Select a modem symbol on the shelf submap in OpenView, then select Maintenance (Maintenance A or Maintenance B for a Dual V.34) from the Configuration menu
- Click on the Select button of the Front Panel display, click on Configuration and select Maintenance from the resulting menu (for a Dual V.34, select Modem A or Modem B after clicking on Select)

The window title bar displays the application name, TEAM Dual V.34 Maintenance or TEAM V.34 Maintenance. The Name field displays the shelf name, the slot number of the unit, for a Dual V.34 the modem (A or B) that is selected, and the symbol label. The main body of the window contains read-only items that display current settings of the maintenance options for the modem. The two pull down menus, File and Edit, allow you to set the maintenance options for the selected modem. Note that only one option can be set at a time.

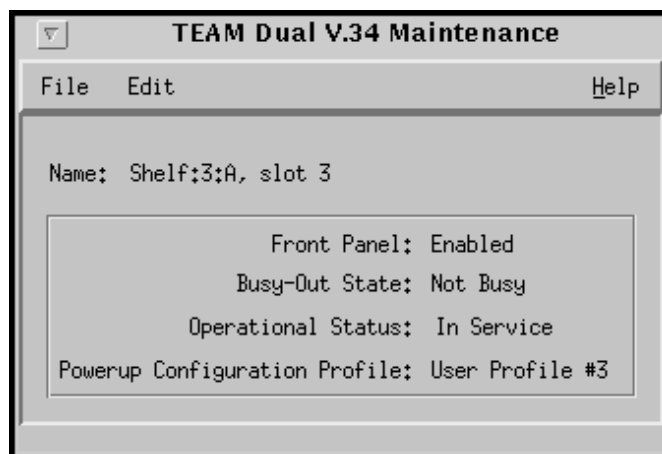

**Table 4-1** Maintenance Window Options

Front Panel	Enabled or Inhibited
Busy-Out State	Busy or Not Busy
Operational Status	In Service or Out of Service
Powerup Configuration Profile	Indicates which of its four User Profiles the modem is to use

### Maintenance Window Definitions

**Front Panel** displays Enabled or Inhibited, indicating whether or not the switches on the front panel of the modem can be used. A selection in the Maintenance window Edit menu controls the Front Panel enable/inhibit function.

**Busy-Out State** displays Busy or Not Busy, indicating whether or not the modem has been set to block incoming calls by presenting a busy signal while off-hook. A selection in the Maintenance window Edit menu controls the Busy-Out function.

**Operational Status** displays In Service or Out of Service.

**Powerup Configuration Profile** displays which of its four User Profiles the modem is to use as its configuration when it is powered On. A selection in the Maintenance window Edit menu controls Powerup Configuration Profile selection.

### Maintenance Window Edit Menu Items

1. Access the Maintenance window, either from the submap menu or from the Front Panel display. The application reads the current maintenance settings from the selected modem when the window is opened.
2. To change any of the maintenance settings, click the mouse on Edit in the menu bar. The application responds with the following menu of options. Each of the menu items, when clicked, displays a selection window to set the options for that item. The settings for each menu item are described below.

Front Panel	Select Enable or Inhibit to determine whether or not the switches on the front panel of the modem can be used.
Busy-Out State	Select Busy or Not Busy to determine whether or not the modem presents a busy signal to block incoming calls while off-hook.
Load Configuration	Select, from Factory Profiles 0 – 3 and User Profiles 0 – 3, the profile the modem is to use as its current operating configuration.
Power Up Configuration Profile	Select the User Profile (Zero, One, Two, or Three) the modem is to use as its operating configuration upon power up or reset.
Private Line Talk/Data	Selects between data mode for normal service and talk mode, in which the modem can activate configuration commands.
In / Out of Service	Selects between In Service, which is the normal operating condition, and Out of Service. The Out of Service state makes the modem appear off-hook to incoming calls, and disables both front panel control and AT control from the DTE. The modem is still accessible to the TEAM controller, which can command it to place outgoing calls.
Soft Reset	Causes the modem (both modems in a Dual V.34) to perform a reset and resume operation using the Power Up User Profile.

Note that the configuration for Alarm Reporting and Alarm Thresholds is not stored as part of the User Profiles, so it is not loaded when you select a profile. Alarm Reporting and Threshold configuration is stored separately and is loaded when you download information from the Configuration window.

## Diagnostics Overview

The Diagnostics/Dial application enables you to perform a variety of tests on the selected modem. Tests can involve just the local unit, or the local unit and the remote modem along with the telephone lines that connect them. The dialing function is incorporated in this window so that you can conveniently make connections for use in testing.

## Diagnostics/Dial Window

The Dial/Diagnostics window is divided into four areas:

- Title bar, menu bar, and Name field.
- Dial/Terminate Call – contains the buttons and field to establish or end connections to remote modems. It also displays Dialer Status and Call Progress Monitor information.
- Diagnostic Test – contains buttons and check boxes for selecting, starting, and stopping the test functions. It also displays Test Status, Errored Bits (results), and Test Time (duration).
- Graphic panel – depicts the path followed by test data during the current test.

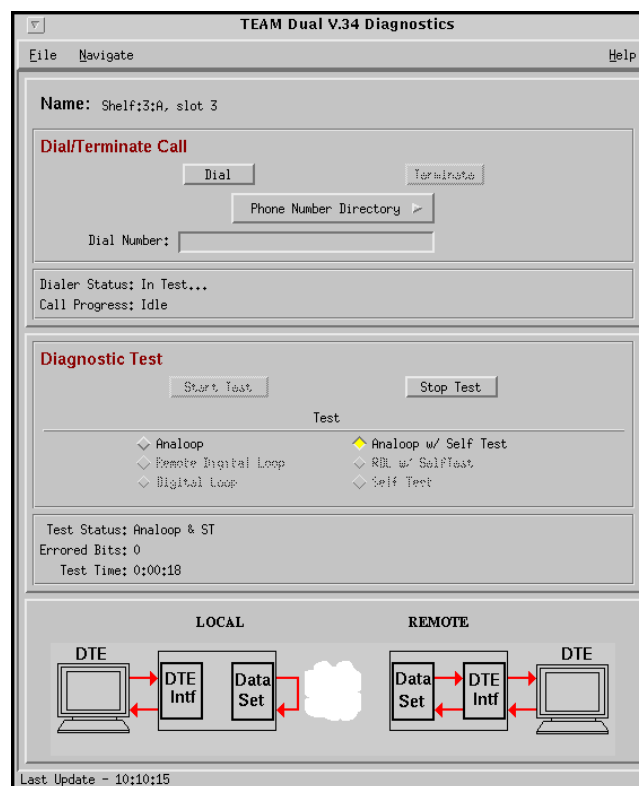

**Table 4-2** Diagnostics/Dial Window Options

Menu Bar	File	Exit
	Navigate	History
	Help	Information on the Diagnostics/Dial functions
Dial/Terminate Call	Dial	Dials the telephone number displayed in the Dial Number field The Dial button is grayed out while the modem is connected to a remote modem.

**Table 4-2** Diagnostics/Dial Window Options (Continued)

Terminate	Terminates the current call. The Terminate button is grayed out when the modem is not connected to a remote modem.
Phone Number Directory	Displays, when you click on it, a list of stored telephone numbers that you can select to appear in the Dial Number field. The list consists of numbers stored in the modem by means of the Telephone Numbers window in the Configuration application. The Dial/Diagnostic application reads the list from the unit while it initializes the Diagnostics window.
<i>Dial Number</i>	Entry field for telephone number selected from the Phone Number Directory or typed in. Edits can be made from the Phone Number Directory, but the changes will not be stored.
<i>Dialer Status</i>	Dynamically updated to indicate the stages of dialing, e.g., Idle, Dialing, Training, etc.
Call Progress	Indicates the state of the transmission line: idle, on-hook, off-hook, busy, dial-tone, connected, and (once the link is established) the current data rates for DCE transmit and receive. This field is dynamically updated.

## Menus

The menu bar contains the selections File, Navigate, and Help. The File menu provides one selection, Exit. The Navigate menu provides a single selection, History, that gives access to a record of test results in the Diagnostic Log window. This chapter describes the Diagnostic Log following the descriptions of tests that can be run from the Diagnostics/Dial window. The Help menu provides access to.

## Dial/Terminate Call

The dialing and call termination functions permit you to make connection to a remote modem in order to perform Remote Digital Loop (RDL), RDL w/ Self Test, Digital Loop, and end-to-end Self Test procedures. Remember when performing any of these tests that you must make the connection to the remote modem before you initiate the test function.

The Digital Loop function also requires an active connection. The purpose of Digital Loop, though, is to direct data from the remote modem back onto the connection for error checking at the far end. Since Digital Loop is used to support testing being performed at the remote modem, the connection for use with this test is most often initiated from the remote modem.

## Dial/Terminate Procedure

Perform the following steps to connect the selected modem to a remote modem.

1. Specify the telephone number to be dialed, by either
  - clicking on the Phone Number Directory button and selecting from the resulting list of stored numbers (the number you select appears in the Dial Number field)
  - or, if the number you need to dial is not stored, click the mouse in the Dial Number entry field and type in the number.
2. Click on the Dial button. The Dialer Status and Call Progress fields display the progress of the process through dialing and the establishment of the connection.
3. To end the connection click on the Terminate button.

## Diagnostic Test

The Diagnostic Test functions select, begin, and end test procedures on the selected modem. Some procedures test the remote modem and the telephone connection as well as the modem.

Under the heading Diagnostic Test there are two buttons, Start Test and Stop Test, and six tests from which you may select:

- Analoop
- Analoop w/ Self Test
- Remote Digital Loop
- RDL w/ Self Test
- Digital Loop
- Self Test

Each test is accompanied by a check box on which you can click to select it as the test to be performed.

---

**Note** *Remote Digital Loop, RDL w/ Self Test, Digital Loop, and Self Test can only be initiated while the modem and its remote modem are on a call passing data, and operating in either synchronous mode or direct (\NI) asynchronous mode. (See the Protocol Options configuration window).*

---

There are three display fields in the Diagnostic Test portion of the window:

*Test Status* – indicates the state of the selected test, e.g., Idle, Initializing, test name while the test is running, Terminating.

*Errored Bits* – indicates the number of bit errors detected during the current (or most recent) diagnostic test. This field is valid for Analoop w/ Self Test, RDL w/ Self Test, and end-to-end Self Test.

*Test Time* – indicates the duration of the current (or most recent) diagnostic test.

## Diagnostic Test Procedure

Perform the following steps to select and carry out a test procedure on the selected modem.

1. If the test is to be Remote Digital Loop (with or without Self Test), Digital Loop, or an End-to-End Self Test, first make sure that the required connection to the remote modem is present.
2. Click on the check box next to the selected test.
3. Click on the Start Test button. The Test Status field changes from Idle to an indication that the test is initializing. It then displays the test name while the test runs. Also while the test runs, the graphic panel at the bottom of the window illustrates the data path employed by the test.

The Errored Bits field is grayed out during any test that does not involve Self Test. During a test that does involve Self Test it displays the number of errors detected. The Test Time field updates at regular intervals (not continuously) while the test runs.

Tests end automatically at the end of the specified period if the Test Time option in the General Options configuration window is set to a numeric value. If that option is set to Continuous, tests run until ended by the Stop Test button. The Stop Test button can also stop a test prior to the Test Time limit that would end it automatically.

- If necessary, click on the Stop Test button to end the test. The Test Status field displays Terminating and then returns to displaying Idle. The Errored Bits and Test Time fields continue to display their values from the most recent past test until another test is performed.

## Diagnostics Table

The table below briefly describes the available tests. Each test is described more fully and illustrated by a diagram under the headings that follow.

Test	Description
Analoop	Modem initiates a local analog loopback, through which the DTE or external test equipment connected to the DTE interface can direct a test pattern.
Analoop w/ Self Test	Modem initiates a local analog loopback and activates its own test pattern generator/checker.
Remote Digital Loop	Modem commands the remote modem to initiate a digital loopback. A test pattern from the DTE or from external test equipment connected to the modem DTE interface can then be directed through the resulting test path.
RDL w/ Self Test	Modem commands the remote modem into digital loopback and activates its own test pattern generator/checker.
Digital Loop	Modem loops data it receives from the remote modem back to the remote modem.
Self Test	Modem activates its test pattern generator/checker.

## Analoop

The Analoop test (See Figure 5-2) lets you isolate problems in the operation of the modem and the DTE interface. Specifically, Analoop checks modulator/demodulator operation in the modem, DTE receive/transmit operation, and DTE interface operation.

---

**Note** When the modem is configured for \N0, \N2, \N3, \N4, or \N5 mode with a fixed DTE speed, it will not issue a CONNECT message. When the modem is used in \N1 mode, since the Analoop handshake speed may not match the DTE speed selected, it issues a CONNECT \_ \_ \_ \_ message at the last known DTE rate. If the DTE rate and handshake rate differ, you can change the DTE speed to match the rate reported by the CONNECT message.

---

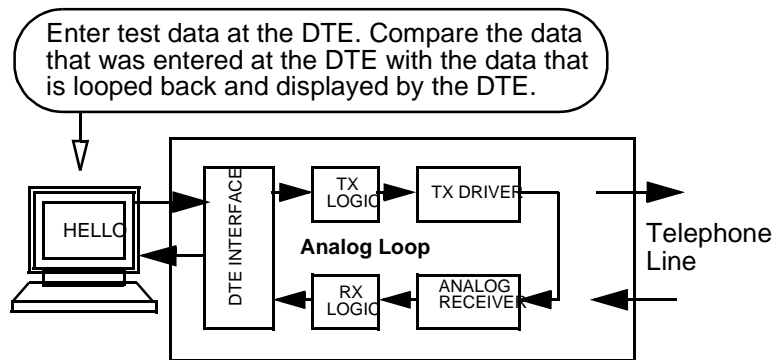

Figure 4-1 Analoop Test

## Analoop with Self Test

Analoop with Self Test employs the same path through the modem as Analoop, but it uses a test pattern generated and checked by the DSE. Because the pattern generator and checker are internal to the DSE, the DTE interface is not part of the Analoop test path for this test.

The self test pattern is composed of alternate ones and zeros for speeds of 1200 and 2400 bps. For all other speeds self test generates a 511 pattern.

The use of Self Test enables the display of test results in the Diagnostic/Dial window. The Errored Bits field displays the number of detected errors.

**Note** This test is not operational when modems are passing data at 300 bps.

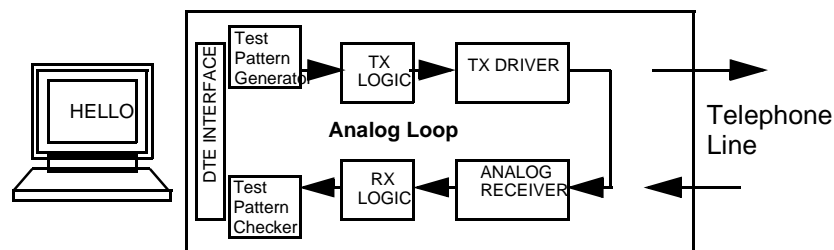

Figure 4-2 Analoop with Self Test

## Remote Digital Loop

In this test the modem sends a Remote Digital Loop command to the remote modem. In response the remote modem couples the unscrambled receive-data from its demodulator to its transmitter input for transmission back to the modem at the local end (See Figure 5-4).

If the Remote Digital Loopback command is sent to a remote unit that is configured to ignore incoming Remote Loopback commands, the local modem will drop the line for V.22 bis speeds only.

**Note** You cannot perform this test if the remote modem is commanded or configured to ignore a remote digital loopback command.

This test is not operational when modems are passing data at 300 bps.

You can only initiate RDL while the modem is on a call passing data, with wire or direct mode selected for the async protocol option (See the Protocol Options window).

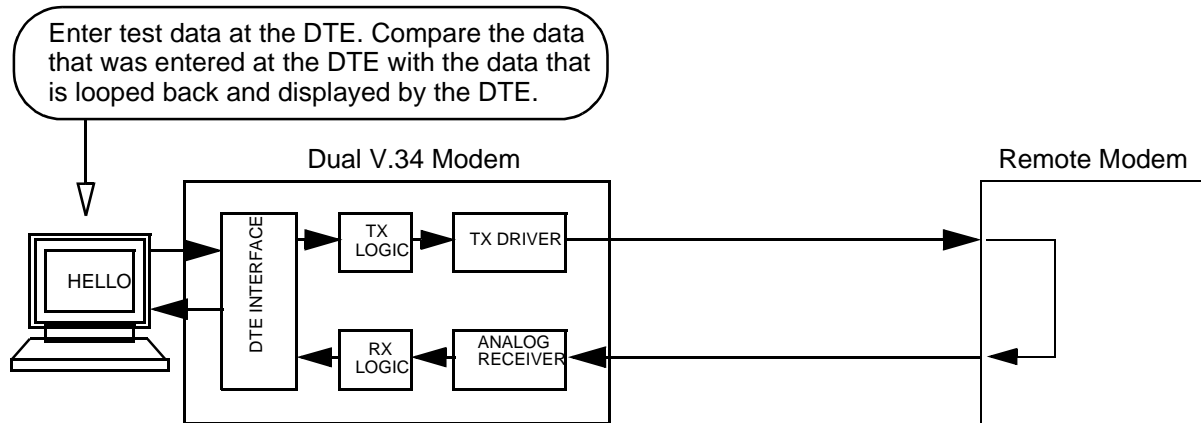

Figure 4-3 Remote Digital Loop

## Remote Digital Loop with Self-Test

In this test the local modem sends a Remote Digital Loop command to the remote modem, then generates a test pattern that it transmits over the telephone line to the remote modem. The remote modem loops the received pattern to its transmitter and sends it back over the telephone line to the modem for analysis (See Figure 5-5). This test checks the modem, the remote modem, and the telephone line.

The self test pattern is composed of alternate ones and zeros for speeds of 1200 and 2400 bps. Self test generates a 511 pattern for all other speeds.

The use of Self Test enables the display of test results in the Diagnostic/Dial window. The Errored Bits field displays the number of detected errors.

**Note** You cannot perform this test if the remote modem is commanded or configured to ignore a remote digital loopback command.

This test is not operational when modems are passing data at 300 bps.

You can only initiate RDL with Self Test while the modem is on a call passing data, with wire or direct mode selected for the async protocol option (See the Protocol Options window).



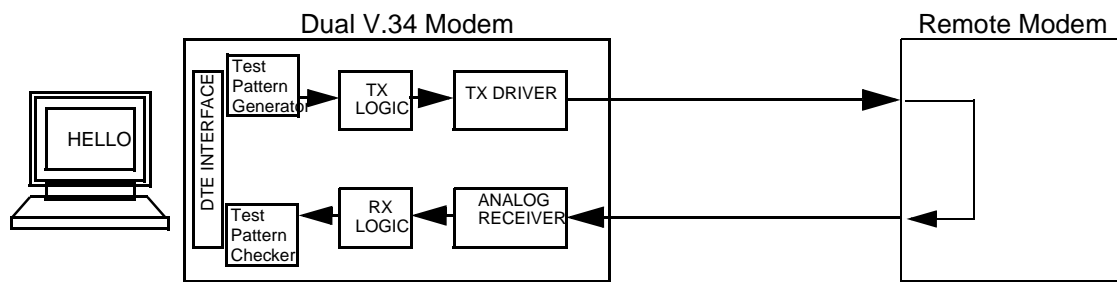

Figure 4-4 Remote Digital Loop with Self Test

## Digital Loop

In Digital Loopback (See Figure 5-6) local receive-data is coupled to the transmitter input so that the remote unit can perform a Loopback test without commanding Remote Loopback. In the asynchronous mode the clocks are clamped at the EIA interface. The remote modem site is responsible for test pattern generation and checking in this test.

**Note** You can only initiate Digital Loop while the modem is on a call passing data, with wire or direct mode selected for the async protocol option (See the Protocol Options window).

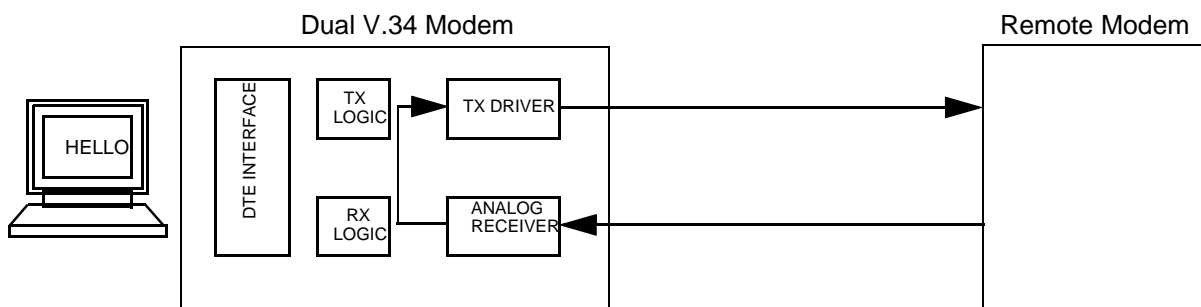

Figure 4-5 Digital Loop

## Self-Test

The Self Test function enables you to perform an end-to-end self test (See Figure 5-7), which is the most complete test of the modem, the remote modem, and the connection between them. In this test the modem and the remote modem each generate and transmit a pattern which is then checked for errors by the unit receiving it.

The self test pattern is composed of alternate ones and zeros for speeds of 1200 and 2400 bps. Self test generates a 511 pattern for all other speeds.

This test requires the cooperation of an operator at the remote modem site to activate the self test function in the remote modem.

The use of Self Test enables the display of test results in the Diagnostics/Dial window. The Errored Bits field displays the number of detected errors received by the modem from the remote modem. Results from the pattern the modem transmits to the remote modem are available at the remote modem site.

**Note** This test is not operational when the modem and the remote modem are passing data at 300 bps. You can only initiate Self Test while the modem is on a call passing data, with wire or direct mode selected for the async protocol option (See the Protocol Options window).

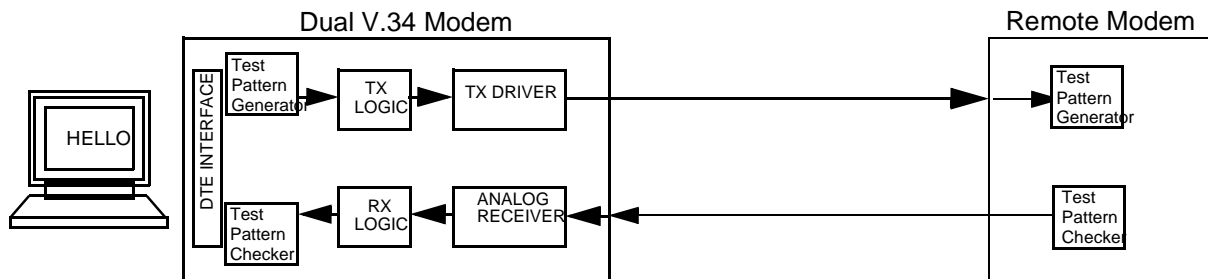

Figure 4-6 End-to-End Self Test

## Diagnostics History

You can view a record of tests performed during the current diagnostic session by selecting History from the Navigate menu in the Diagnostics/Dial window. The record appears as a listing in the Diagnostics History window (see below).

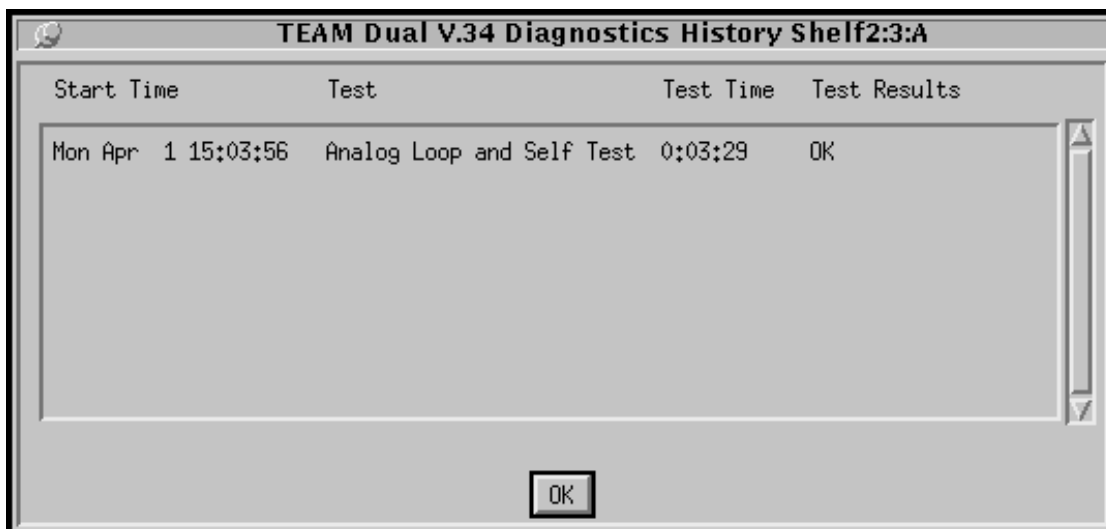

Table 4-3 Diagnostics History Window Options

Start Time	Date and time test began
Test	Name of the test
Test Time	Duration of the test in hours:minutes:seconds format

---

**Table 4-3** Diagnostics History Window Options (Continued)

Test Results	“OK” for a test that does not involve Self Test or for a test with Self Test in which no errors occurred; “Bit Errors:” followed by a bit error number for a test with Self Test in which errors were found
--------------	---

For a test that does not employ Self Test, such as Analoop or Remote Digital Loop, OK in the Test Results column indicates only that the test mode was initiated successfully. Since these test modes provide the data path for a test signal without generating or checking the signal, the application has no error rate data to display for them.

To close the Diagnostics History window, click on the pushpin icon in the upper left corner of the window. During an on-going diagnostic session you can close and re-open the Diagnostics History window without loss of display data.

The application clears the Diagnostics History when you exit from the Diagnostics/Dial window.





