



**Digital Video Broadcasting (DVB);  
Interfaces for DVB Integrated Receiver Decoder (DVB-IRD)**

**DVB Document A016 Rev. 2  
June 1999**

*Reproduction of the document in whole or in part without prior permission of the  
DVB Project Office is forbidden.*

# Contents

Intellectual Property Rights .....	3
1 Scope.....	4
2 References.....	4
2.1 ETSI Baseline documents .....	4
2.2 IEC Publications.....	4
2.3 CENELEC Publications.....	5
2.4 Publications by ETSI .....	5
2.5 Industrial publications .....	5
3 Definitions and abbreviations.....	6
3.1 Definitions.....	6
3.2 Abbreviations .....	6
4 Interface requirements for DVB-IRDs.....	7
4.1 RF input in the satellite IF range .....	7
4.1.1 Polarization switch, LNB's band and first IF input selection.....	7
4.1.2 Azimuth control of a polar mount dish antenna.....	7
4.2 RF input/output in the VHF/UHF range.....	7
4.2.1 RF input.....	7
4.2.2 RF output.....	7
4.3 Modem interface.....	7
4.3.1 PSTN modem.....	7
4.3.1.1 External modem .....	7
4.3.1.1.1 DTE/DCE interface .....	7
4.3.1.1.2 PSTN link interface.....	8
4.3.1.2 Integrated modem.....	8
4.3.2 CATV and SMATV modem.....	8
4.3.2.1 DTE/DCE interface .....	9
4.3.2.2 RF interface to CATV/SMATV network.....	9
4.4 Video signals.....	9
4.4.1 Baseband signals.....	9
4.4.2 RF modulated signals.....	10
4.5 Audio signals.....	10
4.5.1 Analogue audio signals .....	10
4.5.2 Digital audio signals .....	10
4.5.2.1 Linear PCM coded audio signals.....	10
4.5.2.2 Compressed and multi-channel audio signals.....	10
4.5.3 RF modulated signals.....	10
4.6 Data signals output.....	11
4.6.1 Low bitrate serial data port.....	11
4.6.2 High bitrate parallel data port.....	11
4.6.2.1 Connector type.....	11
4.6.2.2 Electrical requirements .....	11
4.6.2.3 IEEE1284 modes .....	11
4.6.2.4 IEEE1284 Peripheral – modes (mandatory) .....	12
4.6.2.5 IEEE1284 Host mode (optional).....	13
4.6.3 High speed serial interface .....	13
4.7 Physical interfaces for control signals .....	14
4.8 Interface for detachable Conditional Access (CA) module.....	14
4.9 Connectors .....	15

**Annex A (informative): Configuration examples.....16**  
**Annex B (informative): National differences on channel assignments in CATV installations .....24**  
Bibliography .....26

## Intellectual Property Rights

IPRs essential or potentially essential to the present document may have been declared to ETSI. The information pertaining to these essential IPRs, if any, is publicly available for **ETSI members and non-members**, and can be found in SR 000 314: *"Intellectual Property Rights (IPRs); Essential, or potentially Essential, IPRs notified to ETSI in respect of ETSI standards"*, which is available **free of charge** from the ETSI Secretariat. Latest updates are available on the ETSI Web server (<http://www.etsi.org/ipr>).

Pursuant to the ETSI IPR Policy, no investigation, including IPR searches, has been carried out by ETSI. No guarantee can be given as to the existence of other IPRs not referenced in SR 000 314 (or the updates on the ETSI Web server) which are, or may be, or may become, essential to the present document.

# 1 Scope

The present document is an application standard, identifying recommended interfaces for connections of Digital Video Broadcast Integrated Receiver Decoder (DVB-IRD) equipment. If a recommended interface is supported, then the full specification of that interface, which may include options, applies. Interfaces not mentioned in the present document are not excluded, and especially interfaces which are under development at the time of drafting the present document may be added at a later stage.

For mechanical and electrical details of the interfaces, reference is made to existing standards of IEC or CENELEC wherever possible, or standards which are known to be in an advanced state of development.

# 2 References

The following documents contain provisions which, through reference in this text, constitute provisions of the present document.

- References are either specific (identified by date of publication, edition number, version number, etc.) or non-specific.
- For a specific reference, subsequent revisions do not apply.
- For a non-specific reference, the latest version applies.
- A non-specific reference to an ETS shall also be taken to refer to later versions published as an EN with the same number.

## 2.1 ETSI Baseline documents

- [1] ETR 289: Digital Video Broadcasting (DVB); Support for use of scrambling and Conditional Access (CA) within digital broadcasting systems

## 2.2 IEC Publications

- [2] IEC 169-2: "Radio frequency connectors, Part 2: coaxial unmatched connector".
- [3] IEC 169-24: "Radio Frequency connectors, Part 24: Radio frequency coaxial connectors with screw coupling, typically for use in 75 Ohm cable distribution systems (type F)".
- [4] IEC 807-9: "Rectangular connectors for frequencies below 3 MHz, Part 9: Detail specification for a range of peritelelevision connectors".
- [5] IEC 933-0: "Preferred matching values for analogue signals".

NOTE: This standard is being developed within the Program of Work of WG7 of IEC/SC100C. At the time of drafting the present document the latest version is 84/421/CDV, whereas the FDIS will circulate for international approval shortly.

- [6] IEC 933-1: "Audio, video and audiovisual systems, interconnections and matching values, Part 1: 21 contact connector for video systems, application No 1".
- [7] IEC 933-5: "Audio, video and audiovisual systems, interconnections and matching values, Part 5: Y/C connector for video systems".
- [8] IEC 958: "Digital audio interface".
- [9] IEC 1030: "Audio, video and audiovisual systems, Domestic digital bus (D2B)".

[10] IEC 1319-1: "Interfaces for satellite receiving equipment, Part 1: Europe".

NOTE: This Technical Report is being developed within the Program of Work of WG7 of IEC/SC100C. At the time of drafting the present document the latest version is 84/418/CDV.

[11] IEC 1883: "Digital interface for consumer electronic audio/video equipment".

NOTE: This specification is currently being developed within the Program of Work of WG11 of IEC/SC100C.

[12] IEC 1937: "Interface for multi-channel non-PCM encoded audio bitstreams".

NOTE: This standard is being developed within the Program of Work of WG11 of IEC/SC100C. At the time of drafting the present document the latest version is the first draft attached to 100C/3/NP.

## 2.3 CENELEC Publications

[13] EN50049-1: "Domestic and similar electronic equipment interconnection requirements: Peritelevision connector".

[14] prEN50157-1: "AVLink, Part 1: Signal quality matching and automatic deselection of source devices".

NOTE: This standard used to be under development within CENELEC TC205. Implementation 3: ESPRIT Home Systems, is referenced to as relevant to DVB-IRD.

## 2.4 Publications by ETSI

[15] ETS 300 158: "Satellite Earth Stations and Systems (SES); Television Receive Only (TVRO-FSS) Satellite Earth Stations operating in the 11/12 GHz FSS bands".

[16] ETS 300 249: "Satellite Earth Stations and Systems (SES); Television Receive-Only (TVRO) equipment used in the Broadcasting Satellite Service (BSS)".

[17] ETS 300 784: "Satellite Earth Stations and Systems (SES); Television Receive-Only (TVRO) satellite earth stations operating in the 11/12 GHz frequency bands".

[18] EN 300 473: "Digital Video Broadcasting (DVB); Satellite Master Antenna Television (SMATV) distribution systems".

## 2.5 Industrial publications

[19] PCMCIA: "PC Card Standard, release 3, Personal Computer Memory Card International Association, Sunnyvale, Cal".

[20] IEEE 1394: "Standard for a high performance serial bus".

[21] IEEE 1284 (1994): "Signalling method for a bi-directional parallel peripheral interface for personal computers".

[22] ANSI/EIA RS232: "Interface between data terminal equipment and data-circuit terminating equipment employing serial binary data interchange".

NOTE: The latest version of this standard is published as RS232E (1991).

## 3 Definitions and abbreviations

### 3.1 Definitions

For the purposes of the present document, the following terms and definitions apply:

**CATV (Community Antenna Television system):** a system designed primarily to provide sound and television signals to communities

**SMATV (Satellite Master Antenna Television system):** a system designed to provide sound and television signals to the households of a building or group of buildings. Two system configurations are defined in EN 300 473 [18] as follows:

- SMATV system A, based on transparent transmodulation of QPSK satellite signals into QAM signals to be distributed to the user;
- SMATV system B, based on direct distribution of QPSK signals to the user, with two options:
  - SMATV-IF distribution on the satellite IF band (above 950 MHz);
  - SMATV-S distribution on the VHF/UHF band, for example the extended S-band (230 MHz to 470 MHz).

### 3.2 Abbreviations

For the purposes of the present document, the following abbreviations apply:

ADSL	Asymmetric Digital Subscriber Loop
BSS	Broadcast Satellite Service
CA	Conditional Access
CENELEC	Comité Européen de Normalisation ELECTrotechnique
CVBS	Composite Video, Blanking and Sync
DTE/DCE	Data Terminal Equipment / Data Communication Equipment
DVB	Digital Video Broadcasting
DVC	Digital Video Cassette
FSS	Fixed Satellite Service
IEC	International Electrotechnical Commission
IRD	Integrated Receiver Decoder
LNB	Low Noise Block converter
PSTN	Public Switched Telephone Network
RLE	Run Length Encoding
VPS	Video Programming System

## 4 Interface requirements for DVB-IRDs

### 4.1 RF input in the satellite IF range

This clause specifies the interface in case of individual dish antenna or SMATV-IF (analogue and digital) installations.

#### 4.1.1 Polarization switch, LNB's band and first IF input selection

The control signal to switch the polarization, the control signal to select the upper or lower band of the LNB, and the first IF input from the LNB to the DVB-IRD shall be as specified in IEC 1319-1 [10], clause 5. The connector is specified in IEC 169-24 [3] (also known as the F-connector), the impedance is 75 Ohm, and output return losses are specified in ETS 300 158 [15], ETS 300 249 [16] and ETS 300 784 [17].

#### 4.1.2 Azimuth control of a polar mount dish antenna

The control signal for the azimuth control of a polar mount dish antenna shall be as specified in IEC 1319-1 [10], clause 6.

### 4.2 RF input/output in the VHF/UHF range

#### 4.2.1 RF input

The RF input in the case of CATV installations, SMATV System A or SMATV-S installations, or in the case of terrestrial reception shall be as follows:

- covers the VHF/UHF frequency bands (47 MHz to 862 MHz);
- 75 Ohm coaxial;
- connector IEC 169-2 [2], female connector on the DVB-IRD.

#### 4.2.2 RF output

The interface for RF output signals shall be as specified in subclause 4.2.1 except for the connector which is IEC 169-2 [2] male version. RF output shall support either loop through only, or RF modulated output from the DVB-IRD, or both. In case of loop through the modulator should output the VHF/UHF frequency bands as specified in subclause 4.2.1. The channel to be used for RF modulated output depends on local circumstances, i.e. occupation of available channels by either terrestrial or cable programmes (see informative Annex B). It is recommended to support the channel range 21 to 69 in UHF.

### 4.3 Modem interface

#### 4.3.1 PSTN modem

A PSTN modem interface provides a low bitrate data channel.

##### 4.3.1.1 External modem

###### 4.3.1.1.1 DTE/DCE interface

The modem shall support:



- a) An interface lead with a 9-pin D-type connector with male shell and female contacts, using RS232C interface levels. The DVB-IRD is seen as the Data Termination Equipment (DTE) and shall be equipped with the mating connector. The pin arrangement shall be as follows:

Pin Number	Name	Function	Source
1	DCD	Carrier Detection	modem
2	RXD	Receive Data	modem
3	TXD	Transmit Data	IRD
4	DTR	Data Terminal Ready	IRD
5	GND	Signal Ground	
6	DSR	Data Set Ready	modem
7	RTS	Request To Send	IRD
8	CTS	Clear To Send	modem
9	RI	Ring Indicator	modem

- b) Auto-mode selection CCITT V.21, V.23 (1200/75), V.22 or V.22 bis transmission protocols (one of these as a minimum). Asynchronous working with one or two stop bits and with or without parity shall be possible. It is recommended that V.32, V.32 bis and V.34 support is included and that the design does not preclude the addition of future enhancements.
- c) Hardware flow control (RTS/CTS) in addition to XON/XOFF flow control.
- d) Control by the Hayes AT command set.
- e) Auto-calling, CCITT V.25 auto-answering and an auto-logon feature.
- f) CCITT V.42 error correction and V.42 bis data compression.

NOTE: V.25 and V.42 are optional extras for a modem interface.

#### 4.3.1.1.2 PSTN link interface

The modem shall be equipped with RJ11 (6 contact) female connector with pin arrangement as follows:

Pin number	Name	Function
1		
2		
3	PSTN	electrical connection
4	PSTN	electrical connection
5		
6		

NOTE 1: PSTN (GSTN) working implies using a PSTN interface cable terminating in a plug which meets national connection requirements given in ETS 300 001 (NET4). The compliance to this interface implies the need for the product to be subjected to type approval by the national regulatory body.

NOTE 2: Approval under the Terminal Equipment Directive 91/263/EEC.

#### 4.3.1.2 Integrated modem

The internal modem shall meet the same requirements as the external modem as specified in 4.3.1.1 with the exception of providing the 9 pin interface connector as specified in 4.3.1.1.1 a).

### 4.3.2 CATV and SMATV modem

A CATV/SMATV modem interface provides a bi-directional data channel. The suitable data rate and the kind of operation depends on the performance of the service.

### 4.3.2.1 DTE/DCE interface

An external modem shall be equipped with an interface lead with a 9 pin D-type connector with male shell and female contacts, using RS232 interface levels. The DVB-IRD is the Data Termination Equipment (DTE) and shall be equipped with the mating connector. The pin arrangement shall be as follows:

Pin number	Name	Function	Source
1			
2	RXD	Receive Data	modem
3	TXD	Transmit Data	IRD
4			
5	GND	Signal Ground	
6			
7			
8			
9			

### 4.3.2.2 RF interface to CATV/SMATV network

The RF interface for both an internal and an external modem shall be as follows:

- impedance 75 Ohm;
- connector IEC 169-2 [2], female on the modem.

It is recommended to use for the carrier in the forward direction:

- a) for CATV, SMATV System A and SMATV-S modem the range of 47 MHz to 862 MHz;
- b) for SMATV-IF modem the range above 850 MHz.

It is recommended to use for the carrier in the return direction the range of 5 MHz to 65 MHz (to be confirmed).

The choice of carrier frequencies depends on the design of the CATV/SMATV network.

## 4.4 Video signals

Analogue video signal output can be either baseband in RGB, Y/C (S-VHS) or CVBS format, or modulated on an RF carrier. The MPEG2 Transport Stream is used to transmit the digital video signals on a high performance serial interface, see subclause 4.6.3.

### 4.4.1 Baseband signals

Matching values for analogue baseband signals  $1 V_{pp}$ . For detailed specifications see any one of the following standards:

- IEC Interface: Preferred matching values for analogue signals.
- IEC 933-1 [6]: 21 contact connector.
- EN 50049-1 [13]: Peritelevision connector.
- prEN50157-1 [14]: AVLink.

NOTE 1: All CVBS related features from PAL services (like VPS, Teletext) which are available on the Peritelevision connector should be made available as usual.

For Teletext there are two possibilities:

- the set top box contains a Teletext decoder, and provides Teletext output as OSD in RGB output signals;

- the set top box does not contain a Teletext decoder, in which case Teletext information is provided in the VBI of the CVBS output signal.

NOTE 2: The DVB standard also provides 2.21:1 (20:9) aspect ratio as an option for the receiver. While displays will only support 4:3 or 16:9, the aspect ratio 2.21:1 will result in a letterbox format. The Peritelevision connector provides following options to deal with aspect ratio 2.21:1 (20:9):

- 6 V signal level on function switch contact 8 is specified to correspond to 16:9 aspect ratio (see EN50049-1 [13]). For optional 20:9 signals the IRD should apply suitable processing as detailed in ETR 154 for display on 4:3 and 16:9 display units.
- the protocol on contact 10 (see prEN50157-1 [14]) includes the option to signal ">16:9". This, when used by the DVB-IRD, will result in proper handling by a 16:9 display unit.

Connectors:

- Peritelevision connector, see IEC 807-9 [4].
- Phono connector.
- 4 contact connector, see IEC 933-5 [7].

#### 4.4.2 RF modulated signals

Video output is also implied in the RF modulated output as described in subclause 4.2.2.

### 4.5 Audio signals

Audio signal output can be in either analogue or digital format, or modulated on RF carrier.

#### 4.5.1 Analogue audio signals

Matching values: 0,5 to 2 V, see IEC 933-0 [5]: Preferred matching values for analogue signals.

Connector:

- Peritelevision, see IEC 807-9 [4].
- Phono connector.

#### 4.5.2 Digital audio signals

##### 4.5.2.1 Linear PCM coded audio signals

This shall be compliant to IEC 958 [8].

NOTE: In case the DVB-IRD includes a surround sound decoder, the multiple analogue outputs thereof would require a number of Phono outputs as identified in subclause 4.5.1.

##### 4.5.2.2 Compressed and multi-channel audio signals

If compressed and multi-channel audio signals are transmitted on IEC 958 [8] then the application specification is based on future IEC 1937 [12].

For other MPEG based audio signal transport see subclause 4.6.3.

#### 4.5.3 RF modulated signals

Audio output (mono only) is also implied in the RF modulated output as described in subclause 4.2.2.

## 4.6 Data signals output

Three interface options are envisaged, each accommodating a range of bitrates and services, i.e. RS232 for low bitrates, IEEE 1284 [21] for bitrates up till about 10 Mbit/s, and IEEE 1394 [20] for bitrates of 100 Mbit/s or more such as MPEG-2 compressed streams or other multimedia data streams.

### 4.6.1 Low bitrate serial data port

This interface can be used to interface to a PC or to other terminals for data including still video images and software.

The DVB-IRD shall be equipped with an interface with a 9 pin D-type socket with female contacts, using ANSI/EIA RS232 [22] interface levels. The pin arrangement shall be as follows:

Pin number	Name	Function	Source
1			
2	RXD	Receive Data	IRD
3	TXD	Transmit Data	PC
4			
5	GND	Signal Ground	
6			
7	RTS	Request To Send	PC
8	CTS	Clear To Send	IRD
9			

The IRD is seen as a Data Communication Equipment (DCE) and the PC (or other terminal) is seen as the Data Terminal Equipment (DTE).

The interface shall support full duplex data transfer, and hardware flow control (RTS/CTS) as well as XON/XOFF flow control.

This interface supports standard data rates up till 19,2 kbit/s, whereas, dependent on length and quality of cable, data rates up till in the order of 100 kbit/s are also possible.

### 4.6.2 High bitrate parallel data port

This interface shall comply with IEEE 1284 [21] standard, with some restrictions as presented in the following subclauses.

#### 4.6.2.1 Connector type

Mandatory: Equipment connector: one D-type connector, **female** 25 pins.

Optional: An additional D-type connector, **female** 25 pins (see 4.6.2.5 for more details).

#### 4.6.2.2 Electrical requirements

The electrical characteristics of the parallel interface shall be compliant with the level 2 electrical interface defined in IEEE 1284 [21].

#### 4.6.2.3 IEEE1284 modes

The IEEE 1284 [21] standard specifies 2 non-exclusive possibilities for a device: it may either be "Host" or "Peripheral". When a device is host, it is the initiator and master of a data exchange sequence. On the contrary, a "Peripheral" device requires a peer "Host" to set up and manage a data transfer sequence.

In case of the DVB-IRD, most applications require the IRD to behave only as a "Peripheral". That is the case for all applications where the IRD is connected to a computer. Therefore, it is mandatory for the IRD to act at least as a peripheral. The set of specific "peripheral – modes" to be supported is detailed furthermore in the next clause.

For some special applications, however, the IRD would have to behave like a "Host". This is for instance the case if the IRD should directly control a printer. This requirement will remain optional, since it is always possible to implement these with the IRD being only "Peripheral", by using a computer as an intervening host. The optional "Host – mode" to be supported is detailed furthermore in subclause 4.6.2.5.

#### 4.6.2.4 IEEE1284 Peripheral – modes (mandatory)

The IRD shall handle as a **Peripheral** the following modes defined in IEEE 1284 [21]: "compatibility mode", "Nibble mode", "Byte mode" and "ECP mode". The handling of the "EPP mode" is not required.

The identification of the external function (device ID string) is not required.

For the "ECP mode" the handling of the RLE (Run Length Encoding) compression is not required.

During "negotiation – phase", the IRD shall adapt the interface to the mode requested by the peer host, within its own possibility range ( i.e.: EPP not supported). . The data transfer path and direction to be set up, depends on the negotiated mode, and may change dynamically between "forward" (Host to Peripheral) and "reverse" (Peripheral to Host), as specified in more detail in the IEEE 1284 [21].

Data rates up to 10 Mbit/s shall be supported.

The pin arrangement (on the DVB-IRD 25 pin D female connector) shall be as follows:

Pin no	Name	Function	Signal direction (seen from IRD side; see note)
1	strobe	indicates new data	i
2	D0	Data bit 0	i/o
3	D1	Data bit 1	i/o
4	D2	Data bit 2	i/o
5	D3	Data bit 3	i/o
6	D4	Data bit 4	i/o
7	D5	Data bit 5	i/o
8	D6	Data bit 6	i/o
9	D7	Data bit 7	i/o
10	/ACK	/Acknowledge	o
11	BUSY	Busy	o
12	PError	Paper Empty	o
13	SELECT	Select	o
14	AUTOFD	Auto Feed	i
15	/FAULT	/Fault	o
16	/INIT	/Initialize	i
17	/SELECTIN	/Select In	i
18	GND	Ground	
19	GND	Ground	
20	GND	Ground	
21	GND	Ground	
22	GND	Ground	
23	GND	Ground	
24	GND	Ground	
25	GND	Ground	

NOTE: "i" = input only; "o" = output only; "i/o" = bi-directional: the direction at a given moment depends on the mode-context.

#### 4.6.2.5 IEEE1284 Host mode (optional)

Only the Host Compatible mode is required, to allow a one way data transfer path towards a printer device. The implication on the signal directions (of the 25 pin D female connector) is as following:

Pin no	Name	Function	Signal direction (seen from IRD side)
1	strobe	indicates new data	o (see note 1)
2	D0	Data bit 0	o
3	D1	Data bit 1	o
4	D2	Data bit 2	o
5	D3	Data bit 3	o
6	D4	Data bit 4	o
7	D5	Data bit 5	o
8	D6	Data bit 6	o
9	D7	Data bit 7	o
10	/ACK	/Acknowledge	i
11	BUSY	Busy	i
12	PError	Paper Empty	i
13	SELECT	Select	i
14	AUTOFD	Auto Feed	o
15	/FAULT	/Fault	i
16	/INIT	/Initialize	o
17	/SELECTIN	/Select In	o
18	GND	Ground	
19	GND	Ground	
20	GND	Ground	
21	GND	Ground	
22	GND	Ground	
23	GND	Ground	
24	GND	Ground	
25	GND	Ground	

NOTE 1: "i" = input only; "o" = output only.

Recommendations: In case the DVB-IRD implements the optional Host-compatible mode it is recommended to use one of the 2 following possibilities:

- 1) Use a dedicated 2<sup>nd</sup> D-type **female** connector, (25 pins). In that case thus, the IRD will have 2 D-type 25 pin connectors: one used for all the applications requiring the "Peripheral" behaviour; and another one used for the application(s) requiring the "Host" behaviour with a one-way data path (e.g.: data flows only from IRD to printer): it is up to the manufacturer to provide clear markings on the rear panel so as to identify the use of each D-type connector.
- 2) The interface uses the same (single) D-type connector, whether the IRD is Peripheral or Host: the switching between Host or Peripheral (with respect to pin signal directions) is application dependent, and care shall be taken to foresee timeouts and appropriate buffering, in case an accidental Host (IRD in host-mode) to Host (PC) connection would be established. By default, the IRD shall be in Peripheral-mode (after power-up), and only goes to Host-mode when the user selects the corresponding application.

NOTE 2: Applications requiring other IRD Host-modes than "Compatible" (e.g.: an IRD connected to a 2<sup>nd</sup> IRD via IEEE 1284) are outside the scope of the present specification, but not in contradiction with it.

#### 4.6.3 High speed serial interface

This interface provides high bitrate of 100 Mbit/s or more for MPEG-2 compressed streams or other multimedia data streams.

The physical, link and transport layers shall be compliant to the cable environment as specified in IEEE 1394 [20]. The following options apply to the DVB-IRD application:

- bitrates of 100 Mbit/s shall be supported. Extension to 200 Mbit/s or 400 Mbit/s is optional;
- the power lines may be deleted, reducing the interface to a 4 wire version for CE A/V purposes, see IEC 1883 [11];
- preferably an IRD should show at least two IEEE 1394 ports;
- the IRD shall be capable of acting as root and performing the isochronous resource management functions.

The packet layer and data format for MPEG2 transport capability shall be compliant to IEC 1883 [11].

## 4.7 Physical interfaces for control signals

Control signals may be embedded in interfaces for data signals, in which case the physical interface for those data signals also apply to the control signals.

Other interfaces, dedicated to the transmission of control signals, may also be used. These interfaces, if used, shall be compliant to one of the following standards:

- IEC 1030 [9] (D2B).
- prEN50157-1 [14], control protocol through contact 10.
- relevant transmission media of Home Systems (coax and twisted pair).

## 4.8 Interface for detachable Conditional Access (CA) module

A Conditional Access (CA) system may be needed to provide access to a broadcast service. One solution for a CA system is a detachable module based on a standardized interface between a module and a host equipment as fully specified in ETR 289 [1]. The physical characteristics of this interface, which uses the PCMCIA specification, are described in Annex A of ETR 289 [1].

Other interfaces are known to be under consideration.

## 4.9 Connectors

The following table provides a list of connectors, pin assignments and signals which are relevant to this standard.

**Table 1: Survey of connectors and pin assignments, used in this standard**

Connector type and Standard	Pin assignment		Connector application / Interface standard
	Pin no.	Signal	
F-type IEC 169-24	--	1st IF from roof top unit	none
RF type IEC 169-2	--	VHF/UHF from Yagi or CATV	IEC 574-3
4 pin Y/C IEC 1076-4-105	3(1) 4(2)	Y signal C signal	IEC 933-5
Peritelevision IEC 807-9	1,2,3,6 (4)	audio	IEC 933-1 EN 50049-1 and Amendments prEN 50157-1
	15(13), 11(9), 7(5)	R/C,G,B/C in/out	
	16 (..)	fast blanking	
	19(17)	CVBS/Y out	
	20(18)	CVBS/Y in	
	8	function switch	
	10(21)	control signal line (prEN50157-1 only)	
12	reserved		
phono (see note 2)	--	digital audio	IEC 958
phono	--	analogue audio	IEC 268-11 IEC 574-3
D2B (see note 3)		D2B	IEC 1030
9 pin D-type (see note 4)	1 2 3 4 5 6 7 8 9	DCD Carrier Detect RXD Receive Data TXD Transmit Data DTR Data Terminal Ready GND Signal Ground DSR Data Set Ready RTS Request To Send CTS Clear To Send RI Ring Indicator	
PCMCIA	see PCMCIA documentation		
IEEE 1394	2 TP (data and timing) power (optional)		IEEE 1394
25 pin D-type			IEEE 1284
NOTE 1: Pin numbers between brackets indicate signal return connections.			
NOTE 2: A detailed component specification of the "Phono" connector does not exist.			
NOTE 3: A detailed component specification of the D2B connector does not exist.			
NOTE 4: This standard specifies three applications of this connector, each with its own subset of the signals.			



## Annex A (informative): Configuration examples

The following diagrams provide examples of DVB-IRD products, featuring the interfaces as specified in this standard. Each version, featuring a certain sub set of the interfaces specified in this standard, can be seen as being specific for a certain market segment. It is left to individual manufacturers to select a certain combination of interfaces in order to reach a certain market segment.

Figure A.1 is a generic diagram showing all interface options. Figures A.2, A.3 and A.4 illustrate the configuration of first generation DVB-IRD devices employing analog interfaces, whereas figure A.5, A.6 and A.7 illustrate configurations based on digital interfaces.

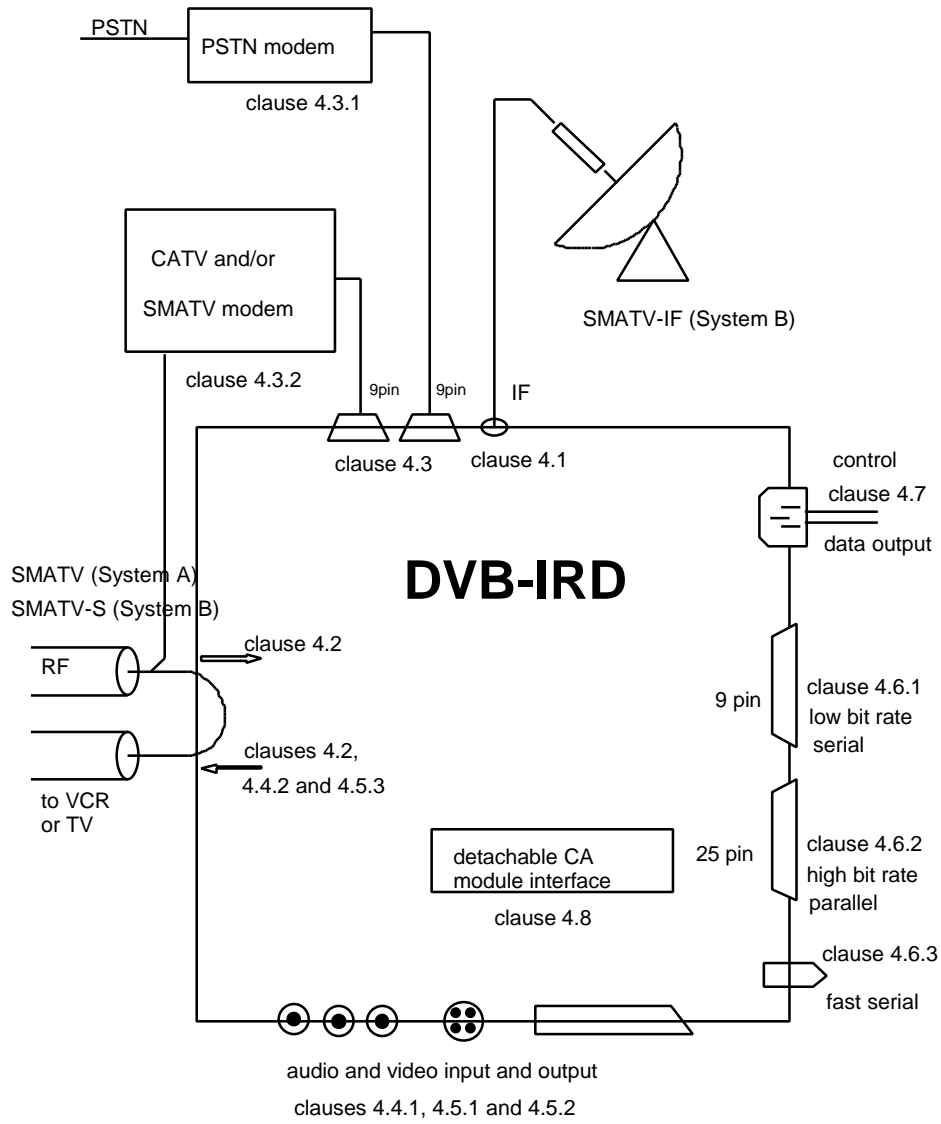

**Figure A.1: Generic diagram, showing all optional interfaces**

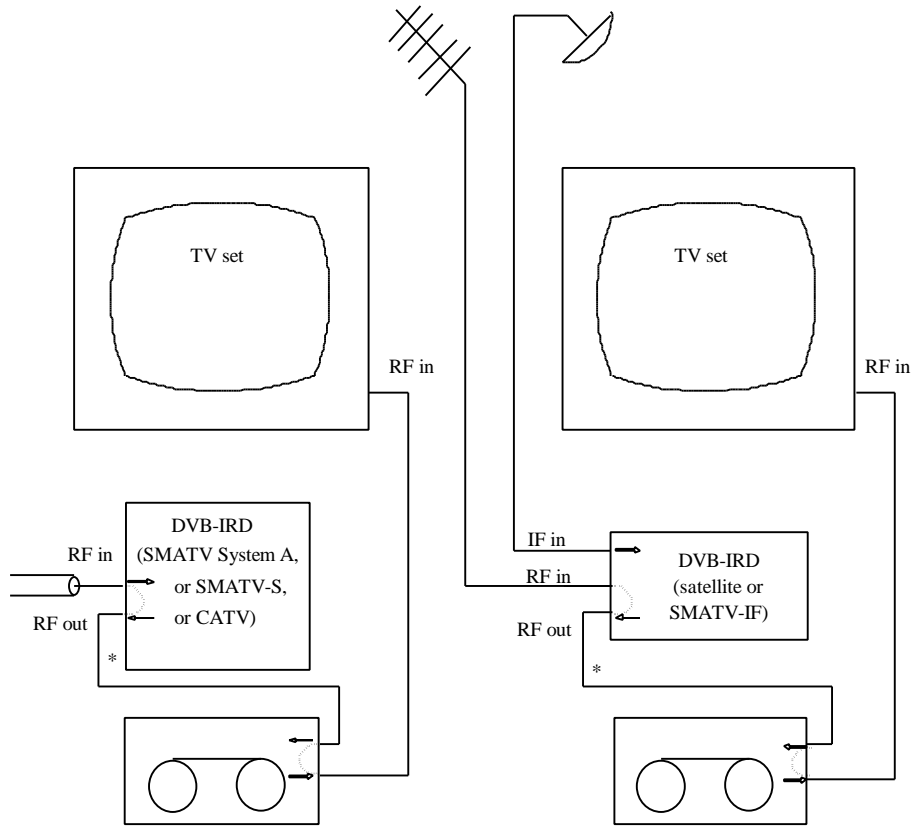

Fig A2a: DVB-IRD for CATV or SMATV System A / SMATV-S reception

Fig A2b: DVB-IRD for satellite or SMATV-IF reception

\* DVB-IRD output towards TV-set is on a RF modulated channel

\* satellite receiver must also support RF loop through

**Figure A.2: Typical low end configuration**

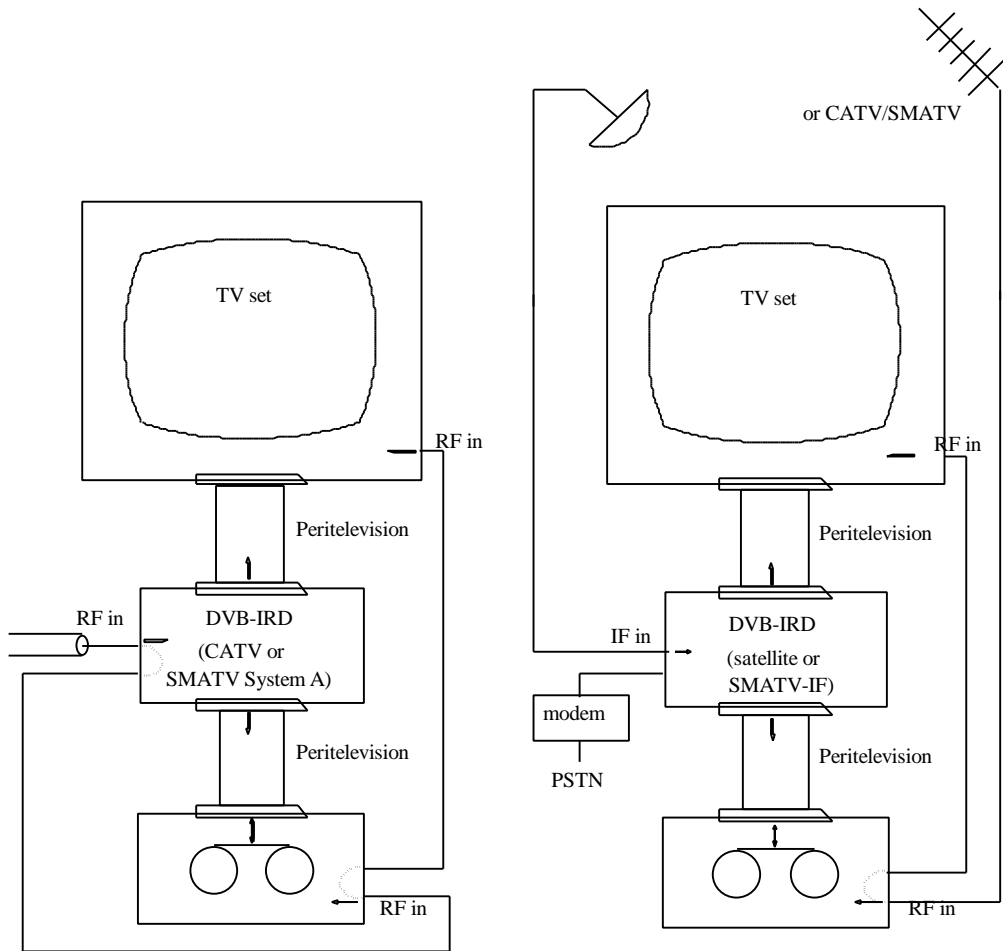
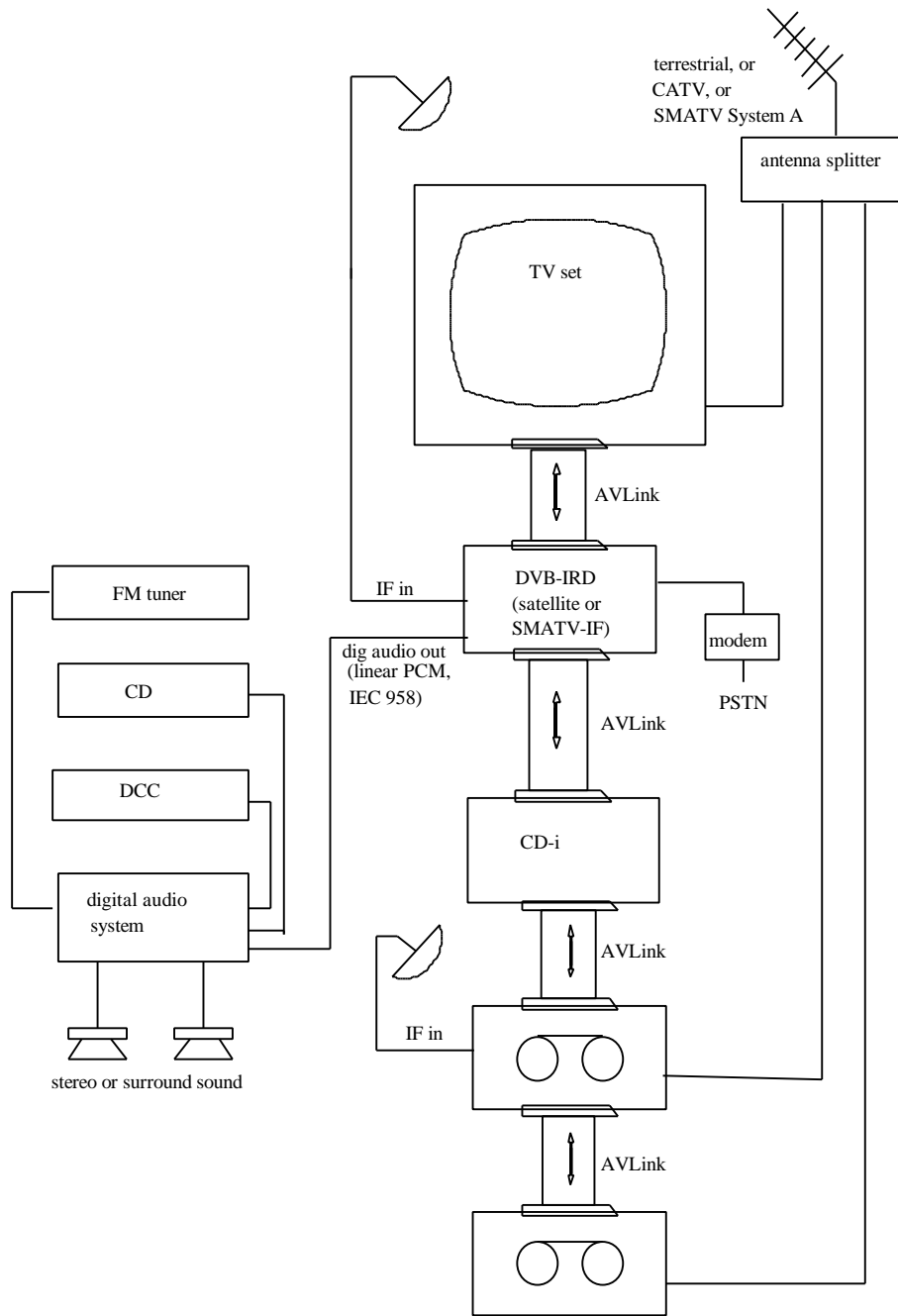

Fig A3a: DVB-IRD for CATV or SMATV System A reception

Fig A3b: DVB-IRD for satellite or SMATV-IF reception

- \* Peritelevision connections in accordance to EN 50049-1
- \* DVB-IRD must provide Peritelevision loop through for recorder to TV set
- \* control of Peritelevision connections through function switch on contact 8
- \* DVB-IRD (cable) must provide vhf/uhf antenna loop through

**Figure A.3: Typical "mid range" configuration**



- \* AVLink connections in accordance with prEN 50157-1
- \* control of AVLink connections through control signal line on contact 10

**Figure A.4: Possible high end configuration**

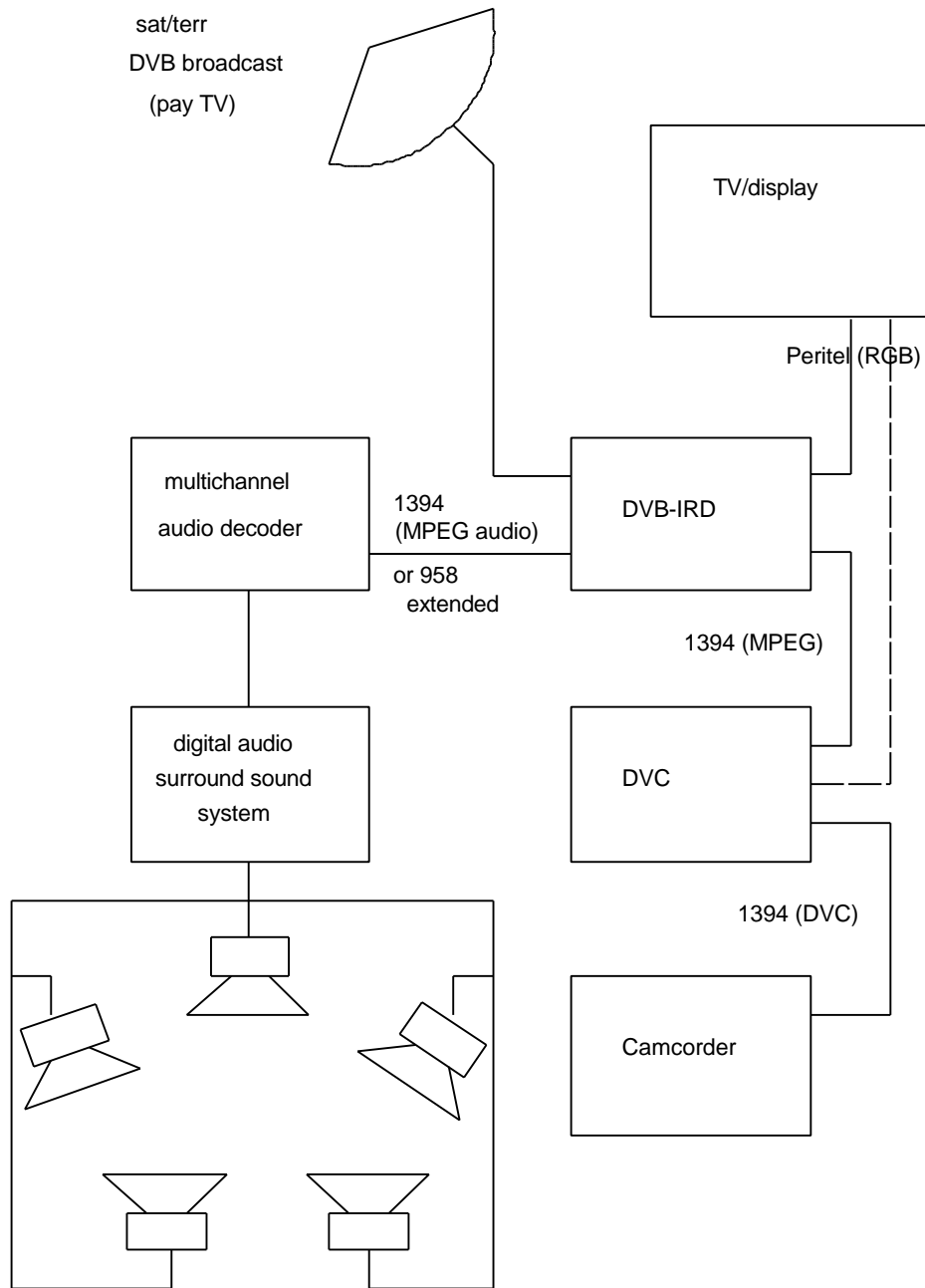

**Figure A.5: Example of DVB-IRD broadcast configuration with high speed serial interface**

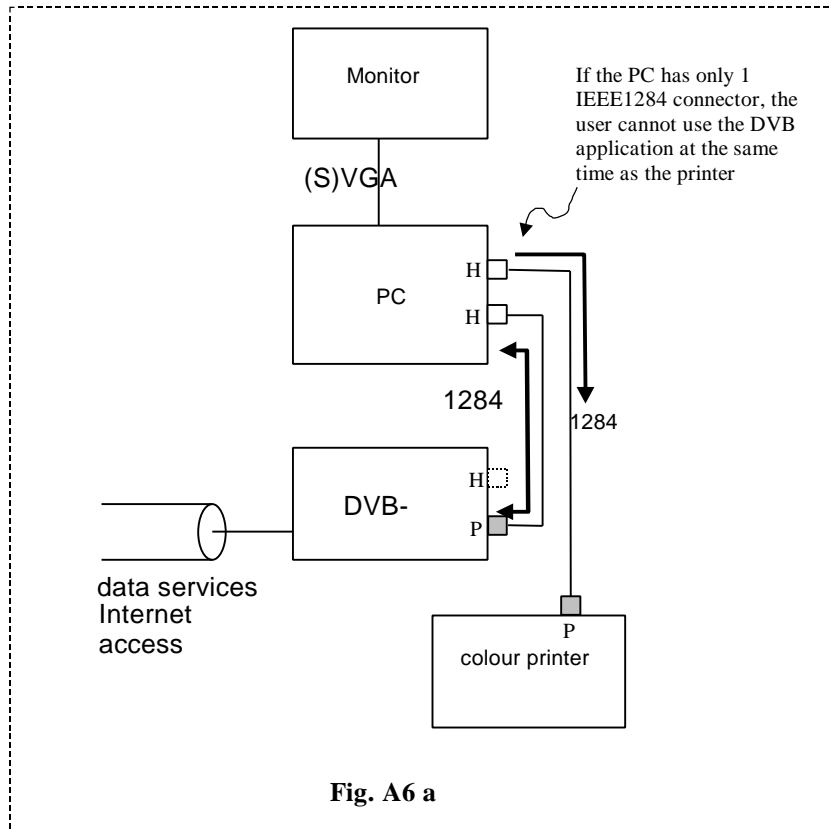

Fig. A6 a

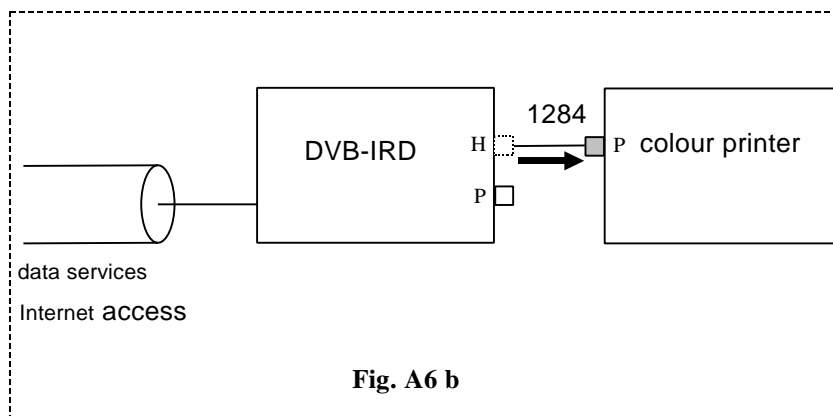

Fig. A6 b

**Figure A.6a: Example of DVB-IRD data services application with high speed parallel interface, employing existing installed base of PC and peripheral equipment (printer) (in this figure the IRD only needs to act as a Peripheral)**

**Figure A.6b: Example of DVB-IRD data services application with high speed parallel interface, directly connected to a printer (in this figure the IRD needs to act as a Host)**

This possibility is optional. For the configuration of Figure A.6a is sufficient since the intervening PC may act as the Host towards the printer device. Unlike the figures suggest, one single D-type female 25 pin connector may be used at the IRD side for both A.6a and A.6b. See details in subclause 4.6.2.5.

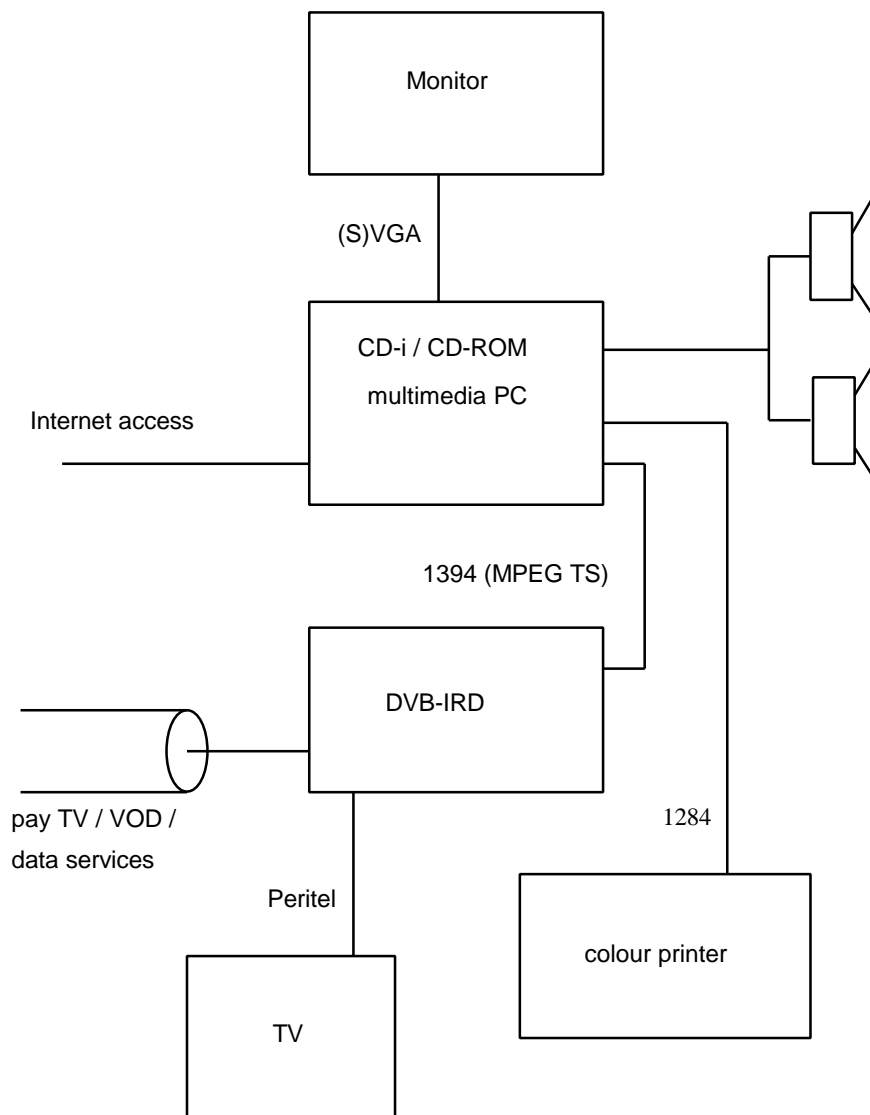

Figure A.7: Example of multimedia DVB-IRD application with high speed serial interface



## Annex B (informative): National differences on channel assignments in CATV installations

The following tables provide a survey of national differences regarding channel assignments on CATV installations.

**Table B.1: Standards for European countries**

Country	VHF	UHF	Colour
Austria	B	G	PAL
Belgium	B	G	PAL
Bulgaria	D	K	SECAM
Bosnia	B	G	PAL
Cyprus	B	G	SECAM
Denmark	B	G	PAL
Finland	B	G	PAL
France	L	L	SECAM
Germany	B	G	PAL
Gibraltar	B	G	PAL
Greece	B	G	SECAM
Hungary	D	K	SECAM
Ireland	I	I	PAL
Iceland	B	G	PAL
Italy	B	G	PAL
Luxembourg	B	G	PAL
Malta	B	-	PAL
Netherlands	B	G	PAL
Norway	B	G	PAL
Poland	D	K	SECAM
Portugal	B	G	PAL
Rumania	D	K	PAL
Russia	D	K	SECAM
Slovenia	D	K	SECAM
Slovakia	D	K	SECAM
Spain	B	G	PAL
Sweden	B	G	PAL
Swiss	B	G	PAL
UK	-	I	PAL

NOTE: Malta is the only exception possibly requiring a special modulator with VHF output channels.

**Table B.2: UHF Channels for standards G, I, K, L (CCIR-Norm, 8 MHz)**

Band	Channel	Channel limits (MHz)	Video carrier (MHz)	Audio carrier (MHz)		
				G	I	K,L
IV	21	470...478	471,25	476,75	477,25	477,75
	22	478...486	479,25	484,75	485,25	485,75
	...	8 MHz...	+ 8 MHz	+ 8 MHz	+ 8 MHz	+ 8 MHz
	...	etc.	etc.	etc.	etc.	etc.
	37	598...606	599,25	604,75	605,25	605,75
V	38	606...614	607,25	612,75	613,25	613,75
	...	8 MHz...	+ 8 MHz	+ 8 MHz	+ 8 MHz	+ 8 MHz
	...	etc.	etc.	etc.	etc.	etc.
	69	854...862	855,25	860,75	861,25	861,75
	70	Not used				
	etc.					

## Bibliography

The following material, though not specifically referenced in the body of the present document (or not publicly available), gives supporting information.

IEC 870-5: "Telecontrol Equipment and Systems, Part 5: Transmission protocols".

IEC 1602: "Connectors used in the field of audio, video and audiovisual engineering".

prEN50090: "Home and Building Electronic Systems".

EN 300 421: "Digital Video Broadcasting (DVB); Framing structure, channel coding and modulation for 11/12 GHz satellite services".

EN 300 429: "Digital Video Broadcasting (DVB); Framing structure, channel coding and modulation for cable systems".

ETR 154: Digital Video Broadcasting (DVB); Implementation guidelines for the use of MPEG-2 Systems, Video and Audio in satellite, cable and terrestrial broadcasting applications