

## Load Paper

---

Step 1 of 4



- 1 Slide the paper width and length adjusters to their outermost positions.

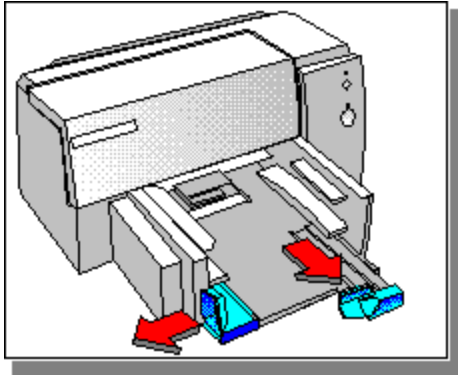

## Load Paper

---

Step 2 of 4



- 2 Insert up to a 3/4-inch (19-mm) stack of paper along the right side of the IN tray, print side down, until it stops.

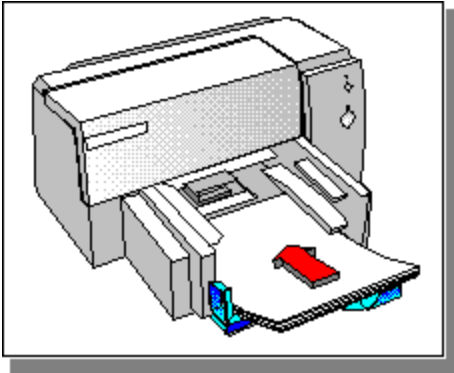

## Load Paper

---

Step 3 of 4



- 3 Slide the paper width and length adjusters in until they stop at the edges of the paper.

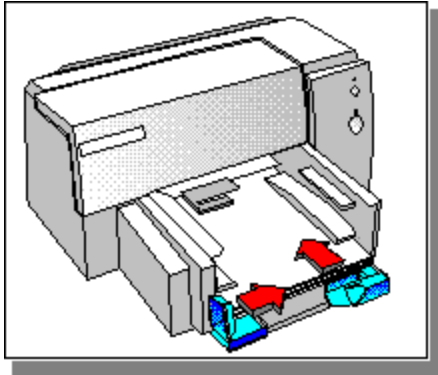

## Load Paper

---

Step 4 of 4



- 4 On the Paper tab in HP's print settings dialog box, change the print settings to match the paper type, size, and orientation, and then click OK.

Click here  for instructions on changing print settings.



## Print Labels

---

Step 1 of 4



- 1 Fan a stack of labels to make sure none of the pages are sticking together.

**Note:** Use only paper labels that are specifically designed for inkjet printers (such as Avery InkJet Labels), and make sure the labels are not over two years old.



## Print Labels

---

Step 2 of 4



- 2 Slide a stack of labels along the right side of the IN tray, print side down, on top of approximately 25 sheets of plain paper.

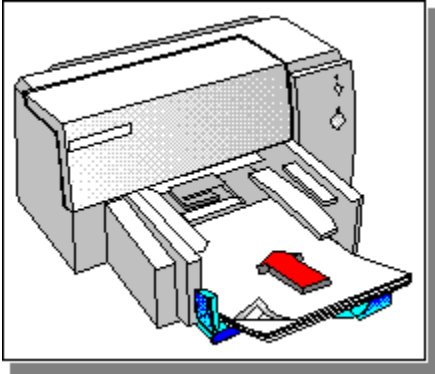

## Print Labels

---

Step 3 of 4



- 3 Slide the paper width and length adjusters in until they stop at the edges of the labels.

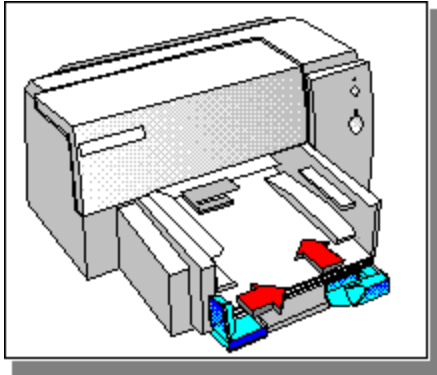

## Print Labels

---

Step 4 of 4

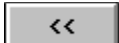

4 Print your labels.





## Print Envelopes Using the IN Tray

---

Step 1 of 5



- 1 Make sure all paper is removed from the IN tray.



## Print Envelopes Using the IN Tray

---

Step 2 of 5



- 2 Slide the envelopes evenly into the IN tray, with the flaps up and to the right, until they stop.

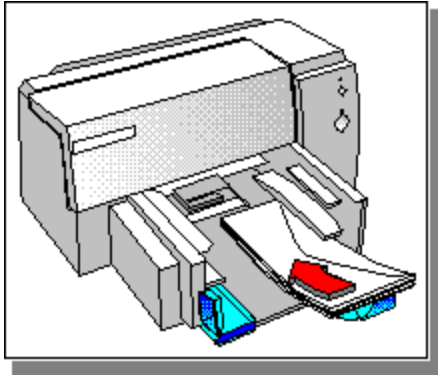

## Print Envelopes Using the IN Tray

---

Step 3 of 5



- 3 Slide the paper width and length adjusters in until they stop at the edges of the envelopes.

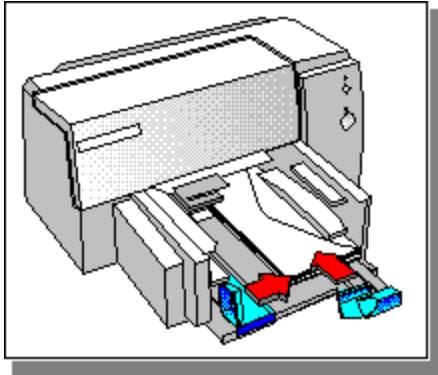

## Print Envelopes Using the IN Tray

---

Step 4 of 5



- 4 In HP's print settings dialog box, click the Paper tab. In the Paper Size box, select the size of envelope you are using, and then click OK.

Click here  for instructions on changing print settings.



## Print Envelopes Using the IN Tray

---

Step 5 of 5



**5** Print your envelope.



## Print on Both Sides of the Page

---

Step 1 of 4



- 1 In HP's print settings dialog box, click the Paper tab. In the Two-sided Printing box, select either Book or Tablet, and then click OK.

Click here  for instructions on changing print settings.



## Print on Both Sides of the Page

---

Step 2 of 4

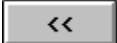

2 Print your document.



## Print on Both Sides of the Page

---

Step 3 of 4

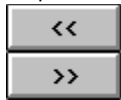

- 3 After all of the odd-numbered pages print, a screen appears with instructions on printing the even-numbered pages. Follow the instructions on the screen.

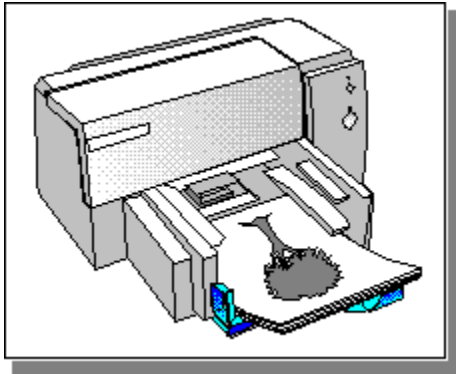



## Print on Both Sides of the Page

---

Step 4 of 4



- 4 When you have removed and reinserted the odd-numbered pages according to the instructions on the screen, click Continue to finish printing your document.

The even-numbered pages will print on the reverse side of the odd-numbered pages.

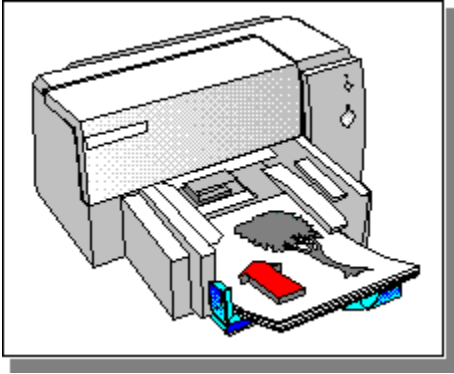

**Book**

Prints using both sides of the page, with the binding along one side of the book. Selecting portrait or landscape page orientation determines the book's edge.

Two-sided printing requires that you manually reinsert the stack of paper into the IN tray. Follow the on-screen instructions for reinserting paper.

**Collate**

To print a multiple page document in order, from last page to first. When printing multiple copies, each copy is printed completely, in order, before printing the next copy.

**ColorSmart technology**

The HP ColorSmart technology within the [HP print settings dialog box](#) analyzes your documents and automatically adjusts the color settings to produce the best possible color output. Although ColorSmart will provide you with the best print quality, you can manually override the settings at any time by selecting the Manual option on the Setup tab of the HP print settings dialog box.

**Continuous (banner) paper**

Paper provided in continuous form, also called computer paper and Z-fold paper. It is usually perforated so that it can be separated into individual sheets.

**Cut-sheet paper**

Standard office, copy, or printer paper pre-cut into individual sheets.

**Default printer**

The printer that is used if you choose the Print command without first specifying which printer you want to use with an application. It should be the printer you use most often.

**Even-numbered pages**

Pages with even numbers, usually the left-hand pages in a book.



**Grayscale**

A grayscale consists of shades of gray, from white to black. When a color document is printed on a black-and-white printer, colors are converted to and represented by their grayscale equivalents.

**HP DeskJet Toolbox**

The HP DeskJet Toolbox provides access to the information you need to use your printer, including procedures for basic printer tasks, step-by-step problem solving for common printing problems, printer status information, and printer functions, such as printing samples pages and aligning print cartridges.

**HP print settings dialog box**

The HP print settings dialog box allows you to access printer features from a software program, such as a word-processing or graphics program. You use the HP print settings dialog box to select print quality, page orientation, paper type, paper size, and ColorSmart options.

**Media**

The paper or other material on which you are printing. Paper, transparencies, labels, and envelopes are examples of media.

**Odd-numbered pages**

Pages with odd numbers, usually the right-hand pages in a book.

**Orientation or page orientation**

The direction in which information is printed on a page. Choose Portrait orientation to print across the width of the page, letter style. Choose Landscape orientation to print across the length of the page, spreadsheet style.

**Printer Services**

Printer Services provide print status information and access to printer functions, such as printing sample pages, diagnostic testing, or aligning print cartridges.

**Tablet**

Prints using both sides of the page, with the binding along the top of the pages. This option reverses the back side of the page so that the pages can be read calendar-style.

Two-sided printing requires that you manually reinsert the stack into the IN tray. Follow the on-screen instructions for reinserting paper.



**Buildtags Start Here**

**Build tag spacer 1**

## Select a Default Printer

---

Step 1 of 3



- 1 On the task bar, click Start, and then select Printers from the Settings menu.



## Select a Default Printer

---

Step 2 of 3



2 Click the icon for your HP DeskJet printer, and then select Set As Default from the File menu.

If Set As Default has a check next to it, your printer is already the default printer.



## Select a Default Printer

---

Step 3 of 3



**3** Click the Close box to close the window.





## Change Print Settings

---



Change print settings for the current document (recommended).

---

Change print settings for all future documents  
(settings may be overridden by your software program).

---

**Build tag spacer 19**



**Build tag spacer 20**

## **Change Print Settings for the Current Document**

Step 1 of 1

---

This procedure will vary depending on the software program you are using.

**1** From the File menu, select Page Setup or Print Setup, and then click Options.

-Or-

From the File menu, select Print, and then click Properties.

---

**Build tag spacer 21**

**Build tag spacer 22**

## **Change Print Settings for All Future Documents**

Step 1 of 3

1 On the taskbar, click Start, and then select Printers from the Settings menu.

-Or-

Click here \_\_\_\_\_ to open the Printers folder now.

## **Change Print Settings for All Future Documents**

Step 2 of 3

---

- 2** Click the icon for your HP DeskJet printer, and then select Properties from the File menu.  
You can now change print settings.
-

## **Change Print Settings for All Future Documents**

---

Step 3 of 3

---

---

**3** Click the Close box to close the window.

---





**Build tag spacer 24**

## **Enable Bi-directional Support**

---

Step 1 of 4

---

---

- 1 Open the Printers folder, click the icon for your HP DeskJet printer, and then select Properties from the File menu.  
Click here [\\_\\_\\_\\_\\_](#) to open the Printers folder now.
-

## **Enable Bi-directional Support**

---

Step 2 of 4

---

---

**2** Click the Details tab.

---

## **Enable Bi-directional Support**

---

Step 3 of 4

---

---

**3** Click the Spool Settings button.

---

## **Enable Bi-directional Support**

---

Step 4 of 4

---

---

- 4** Select the Enable Bi-directional Support For This Printer checkbox.
-

**Build tag spacer 25**

## **Print Directly to the Printer**

---

Step 1 of 4

---

---

- 1 Open the Printers folder, click the icon for your HP DeskJet printer, and then select Properties from the File menu.  
Click here [\\_\\_\\_\\_\\_](#) to open the Printers folder now.
-

## **Print Directly to the Printer**

---

Step 2 of 4

---

---

**2** Click the Details tab.

---



## **Print Directly to the Printer**

---

Step 3 of 4

---

---

**3** Click the Spool Settings button.

---

## **Print Directly to the Printer**

---

Step 4 of 4

---

---

- 4** Select the Print Directly To The Printer checkbox.
-

**Build tag spacer 26**

Dummy topic--do not delete

**HP Banner Paper**

For best results when printing banners use HP Banner Paper. HP Banner Paper will print with fewer paper jams and with brighter color and denser blacks. You also don't have to tear off any perforations. If you decide to use other computer or z-fold paper, use 20-lb. paper and make sure to fan the paper before loading it.

**HP Premium Transparency Film**

For best results when printing presentation slides, use HP Premium Transparency Film. The film coating on HP Premium Transparency Film has been specifically designed to work with HP inks to give you crisp images and text and the fastest drying times.

**HP Premium Glossy Paper**

Use HP Premium Glossy Paper for printing photo images with a glossy finish.

**Labels**

For best results when printing labels, use Avery InkJet Labels which are specifically designed for InkJet printers. If you use other types of labels, they could peel off in your printer or the ink may not dry properly. Make sure you choose labels that are not folded, curled, wrinkled, or partially used. They may get stuck in the printer. Also make sure that they are less than two years old.



**HP Greeting Card Paper**

Use HP Greeting Card Paper to create colorful cards, invitations, and notes for all occasions. HP Greeting Card Paper is pre-scored so that your cards fold precisely into quarters, and customized envelopes are included to fit the cards perfectly. The special coating provides crisp, brilliant colors that won't smudge or smear. You can also choose to mail order card stock that has preprinted borders and designs for every occasion.

## Learn How To

---



Select the button next to the item you wish to learn more about.

---

[Replace Print Cartridges](#)

---

[Load Paper](#)

---

[Change Print Settings](#)

---

[Print on a Variety of Paper Types, Sizes, and](#)

[Envelopes](#)

---

[Use the Printer on a Network](#)

---

To take full advantage of your printer and the online help that accompanies it, use the HP DeskJet Toolbox.

---

## Use the Printer on a Network

---

You can share your HP DeskJet printer on a network in one of the following ways:

### Network Connect

The printer connects to the network using an HP JetDirect EX, EX Plus, or EX Plus3 print-server device.



Click here [\\_\\_\\_\\_\\_](#) for more information.

### Locally Shared

The printer connects directly to the parallel port of a selected computer on the network.



Click here  **HEWLETT  
PACKARD** for more information.  
 **HEWLETT  
PACKARD**

## Network Connect



In a network-connect configuration, the printer connects to the network via direct attachment to an external print server, such as an HP JetDirect EX, EX Plus, or EX Plus3, which is in turn connected to a network node. This configuration provides optimal network performance, flexibility in the printer's physical location, and the ability for users to receive enhanced printer status messaging.

The table below shows which versions of the HP JetDirect EX print server provide enhanced printer status messages. If you have an older HP JetDirect EX Plus print server, you may want to upgrade the firmware (flash memory) using software that is currently available from HP. This option is not available for the original HP JetDirect EX print server devices; however, using these devices will still provide better network printing performance and location flexibility.

	<b>JetDirect EX</b>	<b>JetDirect EX Plus</b>	<b>JetDirect EX Plus3</b>
<b>Limited Status Information</b>	Yes	No	Yes
		Firmware versions prior to E.04.20	Firmware versions prior to D.04.20
<b>Enhanced Status Information</b>	No	Yes	Yes
		Firmware versions E.04.20 and later	Firmware versions D.04.20 and later

### Choose this type of connection when:

- The number of users sharing the printer locally causes a significant decrease in printing performance.
- The printer cannot be conveniently located when using a direct parallel port connection.



## Locally Shared



In a locally shared configuration, the printer is connected directly to the parallel port of a selected computer (or server) on the network. The printer can then be shared by others on the network through a Windows network printer connection.

A locally shared network connection is a low cost, easy way to share a printer because it requires no additional hardware or software. Depending on priority settings and the number of users sharing the printer, the host computer may slow down while handling print jobs, and print jobs may be delayed for others. Also, only the user of the host computer can receive paper or print cartridge related status messages. If the host computer is turned off or rebooted, print jobs may be lost or unable to print.

### Choose this type of connection when:

- Printing performance is satisfactory, based on a small number of users or limited usage.
- The printer, when connected to a specific computer, is conveniently located for all its users.
- The limited printer-related status messaging does not appear to be a problem or impact productivity.



## Print on a Variety of Paper Types, Sizes, and Envelopes



Choose the right paper to use.

Print transparencies or slides.

Print on HP premium papers.

Print labels.

Print on standard-sized paper.

Print on custom-sized paper.

Print envelopes.

Print cards.

## Choose the Right Paper to Use



There are several types of paper you can use to get the best results for the type of document you want to print:



HP Premium Transparency Film



HP Premium Glossy Paper



HP Premium Inkjet Paper



Labels



## Replace Print Cartridges



Step 1 of 6



- 1 Turn on the printer and open the top cover.

The print cartridge cradle moves to the center of the printer, and the Resume  light flashes.





## Replace Print Cartridges



Step 2 of 6



- 2 Flip up the print cartridge latch, grasp the top of the empty print cartridge, and pull it up and out of its cradle.

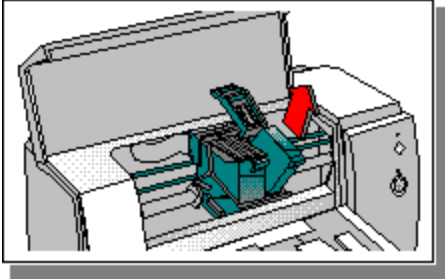

## Replace Print Cartridges



Step 3 of 6



- 3 Remove the new print cartridge from its package, and gently remove any tape covering the ink nozzles, being careful not to touch the ink nozzles or the contacts.

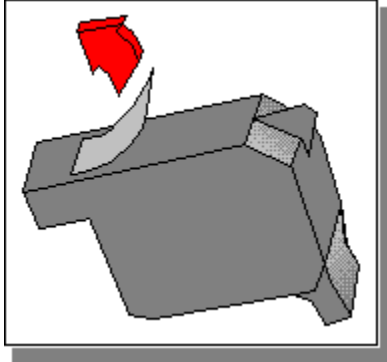

## Replace Print Cartridges



Step 4 of 6



- 4 Push the new cartridge down firmly into its cradle slot, and close the print cartridge latch.

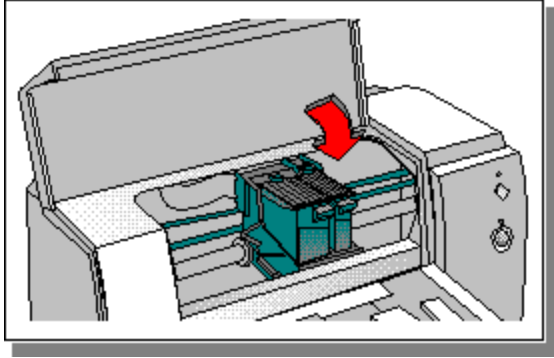

## Replace Print Cartridges



Step 5 of 6



5 Close the printer's top cover.



## Replace Print Cartridges



Step 6 of 6



6 Align the print cartridges for best print quality.

Click here  to align the print cartridges now.



## Print on Custom-Sized Paper



Step 1 of 5



1 In HP's print settings dialog box, click the Paper tab. In the Paper Size box, select Custom.

The Custom Paper Size dialog box appears.

Click here  [HEWLETT  
PACKARD](#) for instructions on changing print settings.



## Print on Custom-Sized Paper



Step 2 of 5



2 Under Paper Size, type values in the Width and Length boxes, and then click OK.

**Note** The paper width must be between 3.9 inches and 8.5 inches (100 mm and 215 mm); the paper length must be between 5.8 inches and 14 inches (148 mm and 356 mm).

---



## Print on Custom-Sized Paper



Step 3 of 5



- 3 Insert up to a 3/4-inch (19-mm) stack of paper along the right side of the IN tray, print side down, until it stops.





## Print on Custom-Sized Paper



Step 4 of 5



- 4 Slide the paper width and length adjusters in until they stop at the edges of the paper.



## Print on Custom-Sized Paper



Step 5 of 5



5 Print your document.



## Print Envelopes



You can print single envelopes using the single-sheet feeder, or you can print up to 15 envelopes using the IN tray.  
Select the method you want to use:



Single envelope

Multiple envelopes

## Print Envelopes Using the Single-Sheet Feeder



Step 1 of 5



- 1 Adjust the single-sheet feeder to accommodate the width of the envelope you are using.

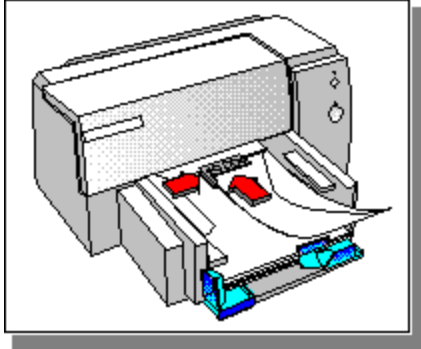

## Print Envelopes Using the Single-Sheet Feeder



Step 2 of 5



- 2 Slide the envelope into the single-sheet feeder, with the flap up and to the right, until it stops.

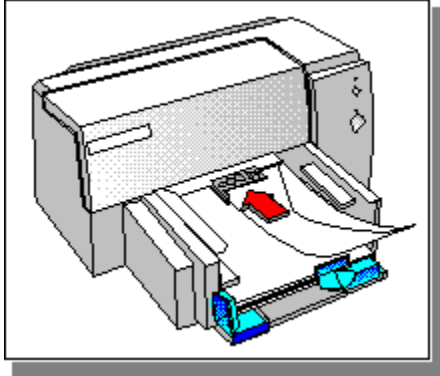

## Print Envelopes Using the Single-Sheet Feeder



Step 3 of 5



**3** Adjust the single-sheet feeder so that the right edge of the envelope is aligned with the right edge of the IN tray.



## Print Envelopes Using the Single-Sheet Feeder



Step 4 of 5



- 4 In HP's print settings dialog box, click the Paper tab. In the Paper Size box, select the size of envelope you are using, and then click OK.

Click here  [HEWLETT PACKARD](#) for instructions on changing print settings.



## Print Envelopes Using the Single-Sheet Feeder



Step 5 of 5



5 Print your envelope.





## Print Cards



Step 1 of 4



- 1 Insert up to a 3/4-inch (19-mm) stack of cards along the right side of the IN tray, with the print side down and the short edge at front, until it stops.



## Print Cards



Step 2 of 4



2 Slide the paper width and length adjusters in until they stop at the edges of the cards.



## Print Cards



Step 3 of 4



- 3 In HP's print settings dialog box, click the Paper tab. In the Paper Size box, select the size of the cards you are printing, and then click OK; or, select Custom if none of the sizes match the card size you are printing.

Click here  [HEWLETT  
PACKARD](#) for instructions on changing print settings.

Click here  [HEWLETT  
PACKARD](#) for instructions on printing on custom-sized paper.



## Print Cards



Step 4 of 4



4 Print your cards.



## Print on Standard-Sized Paper



Step 1 of 4



- 1 Insert up to a 3/4-inch (19-mm) stack of paper along the right side of the IN tray, print side down, until it stops.



## Print on Standard-Sized Paper



Step 2 of 4



- 2 Slide the paper width and length adjusters in until they stop at the edges of the paper.



## Print on Standard-Sized Paper



Step 3 of 4



3 In HP's print settings dialog box, change the necessary print settings, and then click OK.

Click here  for instructions on changing print settings.



## Print on Standard-Sized Paper



Step 4 of 4



4 Print your document.





## Clear a Paper Jam



Step 1 of 5



1 Open the printer's top cover.



## Clear a Paper Jam



Step 2 of 5



- 2 Press and hold down the Resume  button.

The paper will move in one direction.



## Clear a Paper Jam



Step 3 of 5



- 3 If necessary, remove the IN tray to remove any wrinkled and torn paper. Replace the IN tray and load new paper.

Click here  for instructions on loading paper.



## Clear a Paper Jam



Step 4 of 5



4 Close the printer's top cover.



## Clear a Paper Jam



Step 5 of 5



5 Turn the printer off, and then turn it back on.



## Print on HP Premium Papers



Step 1 of 4



**Note** Use HP Premium InkJet or Glossy Papers, which are specifically designed to work with your HP DeskJet printer, or use other premium paper designed to work with inkjet printers.

---

- 1 Insert HP Premium InkJet or Glossy Paper in the IN tray.

Click here  [HEWLETT PACKARD](#) for instructions on loading paper.



## Print on HP Premium Papers



Step 2 of 4



2 In HP's print settings dialog box, click the Paper tab. In the Paper Type box, select the type of paper you are using:

- **HP Glossy Paper**, designed to produce the highest quality printouts with standard print cartridges
- **HP Glossy Paper (Pause Control)**, designed for printing in a high-humidity environment where glossy pages might dry slowly
- **HP Premium InkJet Paper**, designed to give you higher quality black and color output than plain paper

Click here  for instructions on changing print settings.



## Print on HP Premium Papers



Step 3 of 4



**3** Click the Setup tab. In the Print Quality box, select Best, and then click OK.





## Print on HP Premium Papers



Step 4 of 4



4 Print your document.



## Print Transparencies or Slides



Step 1 of 6



**Note** Use HP Premium Transparency Film, which is specifically designed to work with your HP DeskJet printer, or use other transparency film designed to work with inkjet printers.

---

- 1 Insert HP Premium Transparency Film in the paper tray with the rough side down and the adhesive strip forward.



## Print Transparencies or Slides



Step 2 of 6



2 In HP's print settings dialog box, click the Paper tab. In the Paper Type box, select one of the following:

- **Transparency** to print transparencies normally.
- **Transparency (Pause Control)** to manually remove each transparency from the OUT tray for drying. A dialog box appears after each page prints. Remove the transparency and click OK to continue printing.

Click here  for instructions on changing print settings.



## Print Transparencies or Slides



Step 3 of 6



**3** In the Paper Size box, select Letter.



## Print Transparencies or Slides



Step 4 of 6



4 Click the Setup tab, and in the Print Quality box, select Best.



## Print Transparencies or Slides



Step 5 of 6



5 Change any other print settings, if necessary, and then click OK.



## Print Transparencies or Slides



Step 6 of 6



6 Print your transparency or slide.



**Enhanced status messaging**

The ability for the printer to send popup alert messages to the user whenever its normal printing status is interrupted. These include messages about print cartridges, paper jams, out-of-paper conditions, and other printer-related alerts.



**Network**

A system of computers and other equipment set up for sharing files, data, and resources, such as printers and scanners. A LAN, or local area network, in its smallest form may consist of two computers and a printer that both can share. A larger LAN may connect members of a workgroup, such as an accounting department where users have similar requirements for sharing data and resources.

**HP Premium InkJet Paper**

Use HP Premium InkJet Paper for printing presentations, final copies of important documents, charts, and graphs. HP Premium InkJet Paper gives you sharper, brighter colors and superior black text compared to plain paper.

