

Learn How To



Select the button next to the item you wish to learn more about.



[Replace Print Cartridges](#)



[Load Paper](#)



[Change Print Settings](#)



[Print on a Variety of Paper Types, Sizes, and Envelopes](#)



[Print on Both Sides of the Page](#)

To take full advantage of your printer and the online help that accompanies it, use the HP DeskJet Toolbox.



Load Paper

Step 1 of 4



- 1 Slide the paper width and length adjusters to their outermost positions.

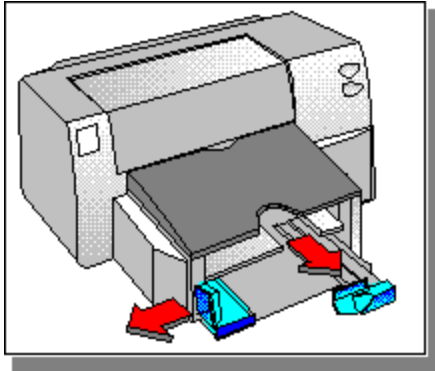

Load Paper

Step 2 of 4



- 2 Insert up to a 3/4 inch (19 mm) stack of paper along the right side of the IN tray, print side down, until it stops.

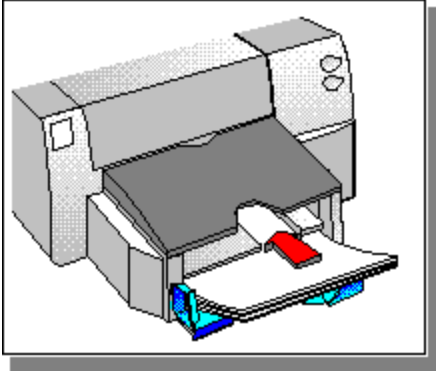

Load Paper

Step 3 of 4



- 3 Slide the paper width and length adjusters in until they stop at the edges of the paper.

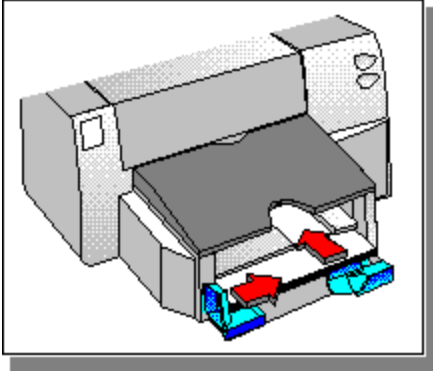

Load Paper

Step 4 of 4



- 4 On the Paper tab in HP's print settings dialog box, change the print settings to match the paper type, size, and orientation, and then click OK.

Click here  for instructions on changing print settings.



Print on Transparencies or Slides

Step 1 of 6



Note Use HP Premium Transparency Film, which is specifically designed to work with your HP DeskJet printer, or use other transparency film designed to work with inkjet printers.

- 1 Insert HP Premium Transparency Film in the paper tray with the rough side down and the adhesive strip forward.

Click here  for instructions on loading paper.



Print on Transparencies or Slides

Step 2 of 6



2 In HP's print settings dialog box, click the Paper tab. In the Paper Type box, select one of the following:

- **Transparency** to print transparencies normally
- **Transparency (Pause Control)** to manually remove each transparency from the OUT tray for drying. A dialog box appears after each page prints. Remove the transparency and click OK to continue printing.

Click here  for instructions on changing print settings.



Print on Transparencies or Slides

Step 3 of 6

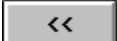

3 In the Paper Size box, select Letter.



Print on Transparencies or Slides

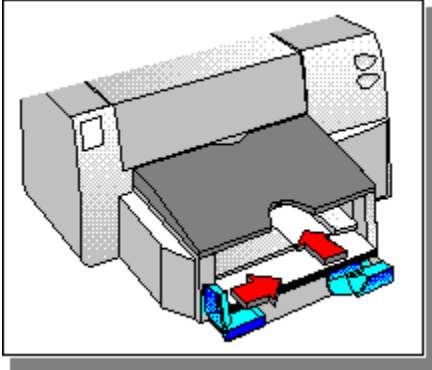

Step 4 of 6

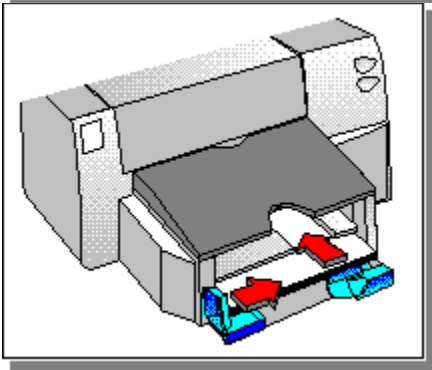
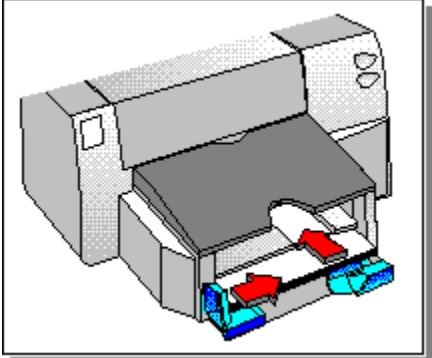

4 Click the Setup tab, and in the Print Quality box, select Best.

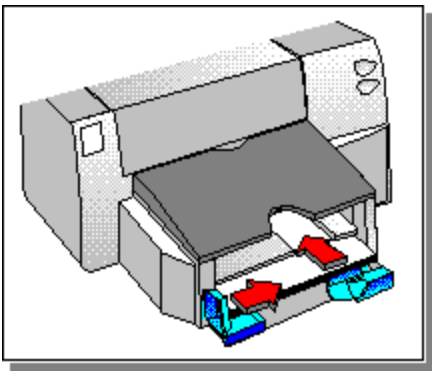

Print on Transparencies or Slides

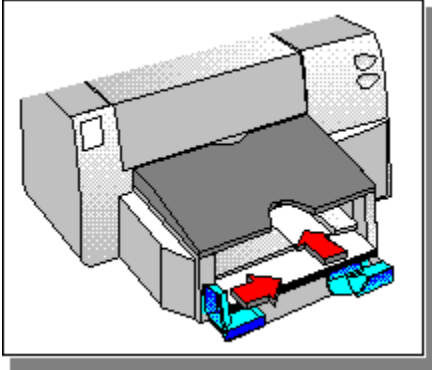

Step 5 of 6

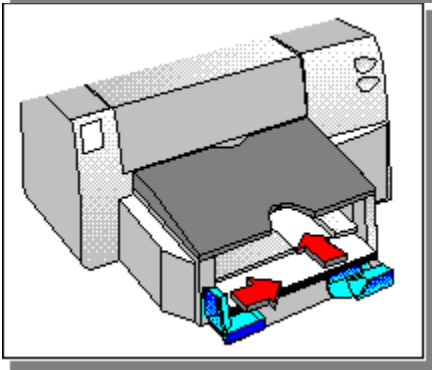
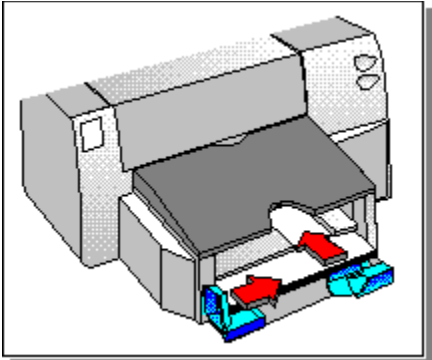

5 Change any other print settings, if necessary, and then click OK.

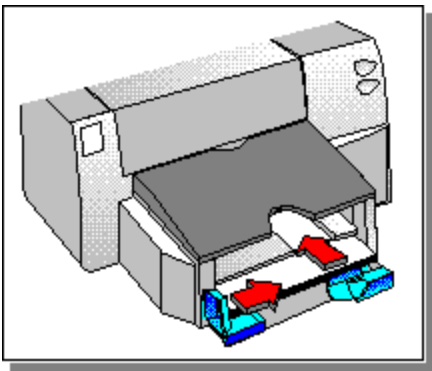

Print on Transparencies or Slides

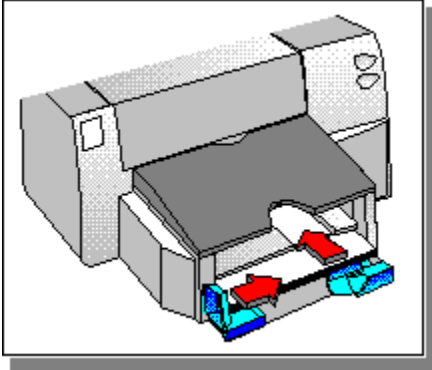

Step 6 of 6

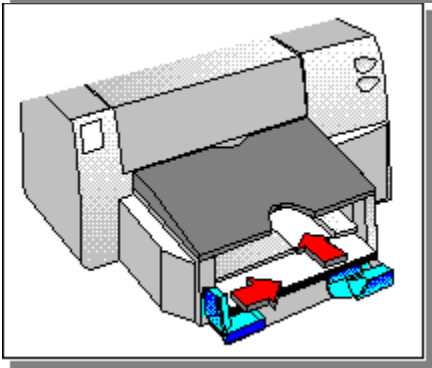
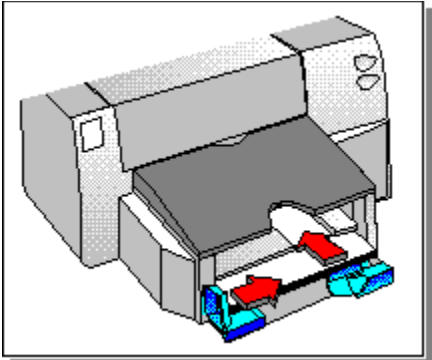

6 Print your transparency or slide.

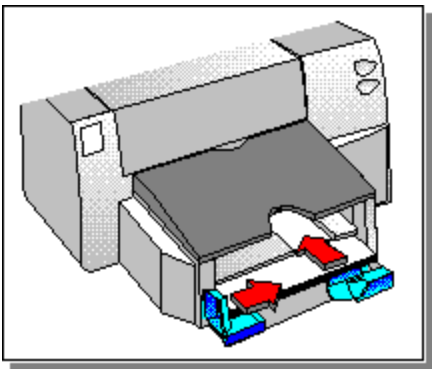

Print on HP Premium Papers

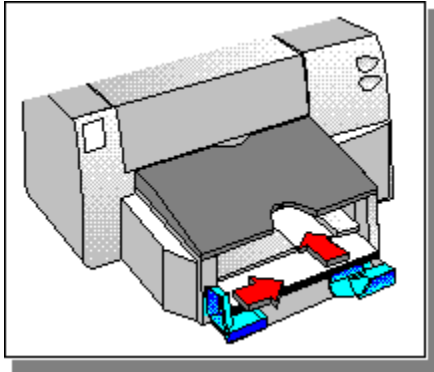

Step 1 of 4

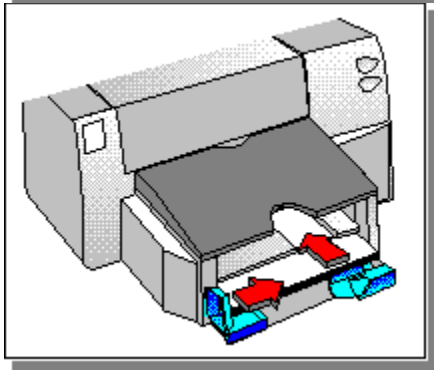
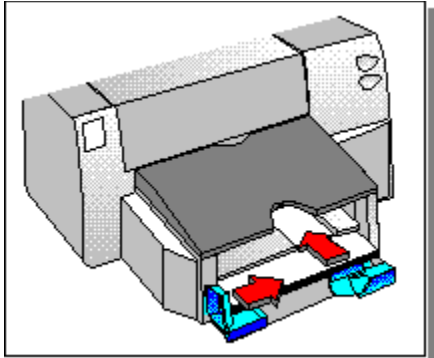

Note Use HP Premium InkJet or Glossy Papers, which are specifically designed to work with your HP DeskJet printer, or use other premium paper designed to work with inkjet printers.

- 1 Insert HP Premium InkJet or Glossy Paper in the IN tray.

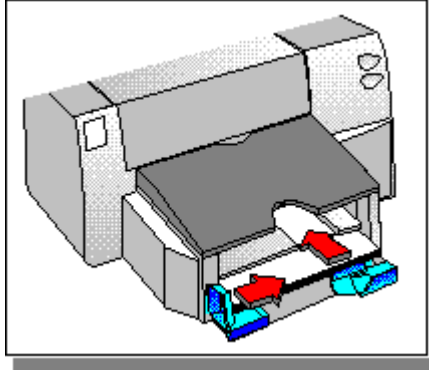

[Click here](#)

for instructions on loading paper.

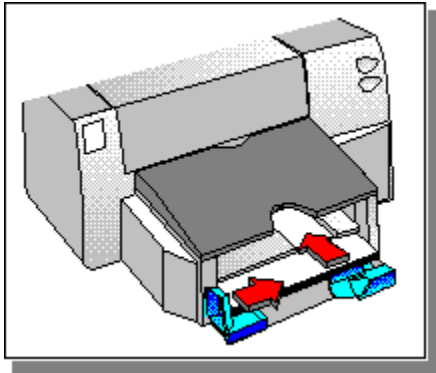

Print on HP Premium Papers

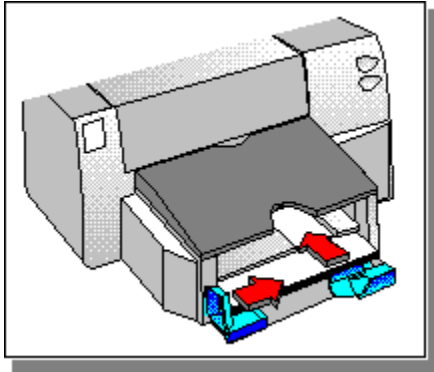

Step 2 of 4

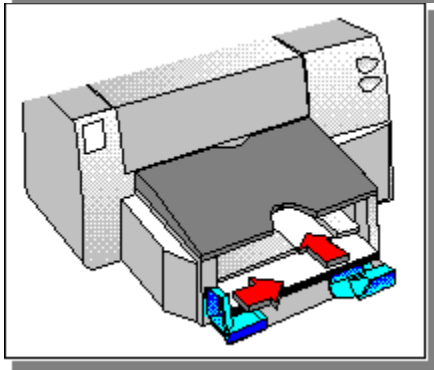
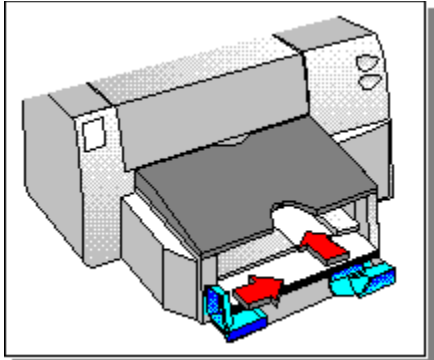

- 2 In HP's print settings dialog box, click the Paper tab. In the Paper Type box, select the type of paper you are using:

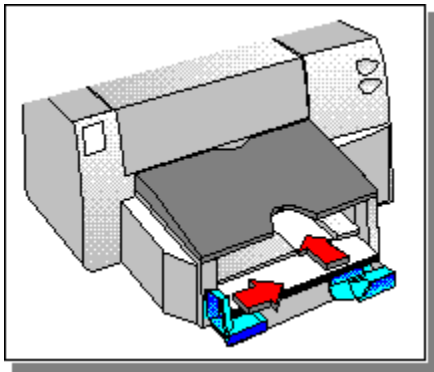

HP Glossy Paper, designed to produce photographic-quality printouts

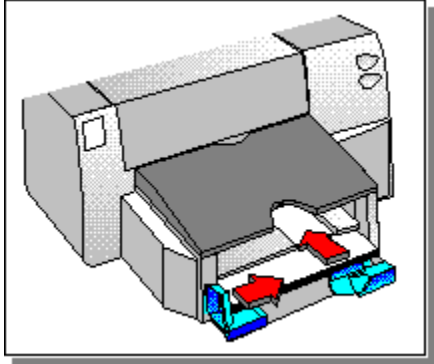

HP Glossy Paper (Pause Control) for printing in a high-humidity environment where glossy pages might dry slowly

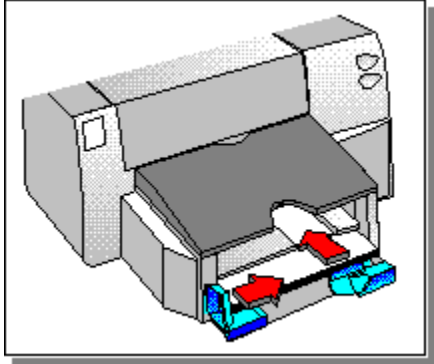

HP Premium InkJet Paper, designed to enhance black or color output

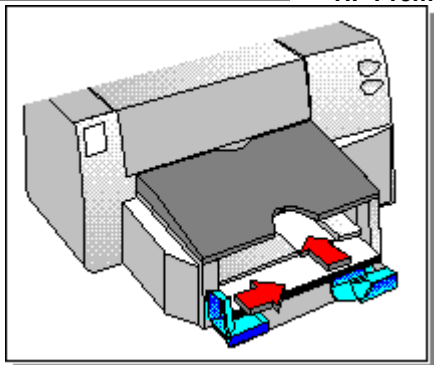

[Click here](#)

for instructions on changing print settings.

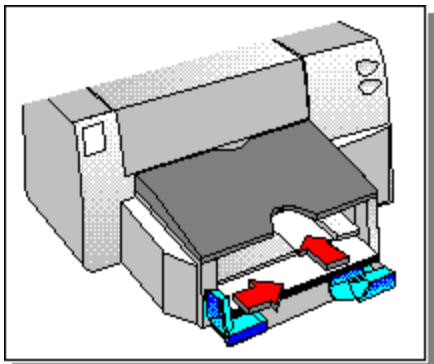

Print on HP Premium Papers

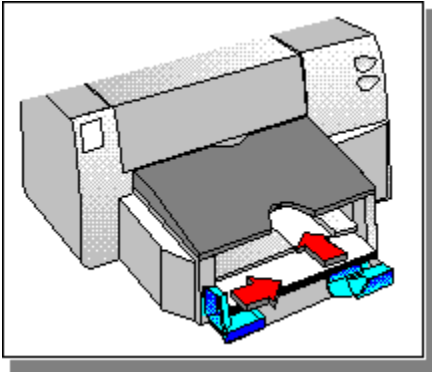

Step 3 of 4

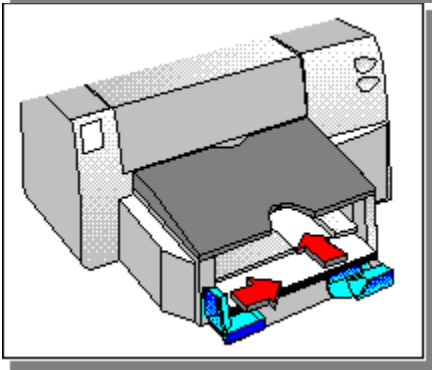
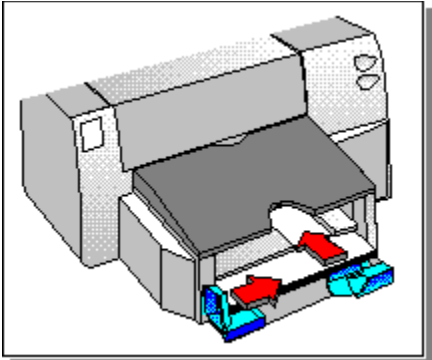

3 Click the Setup tab. In the Print Quality box, select Best, and then click OK.

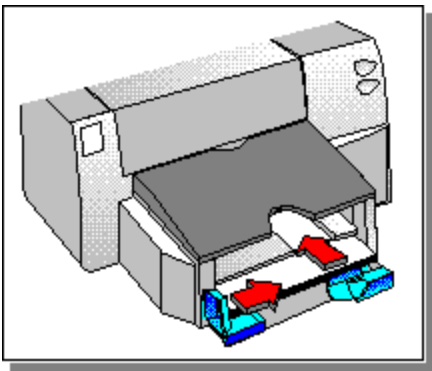

Print on HP Premium Papers

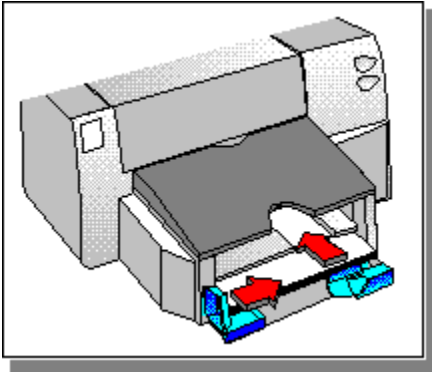

Step 4 of 4

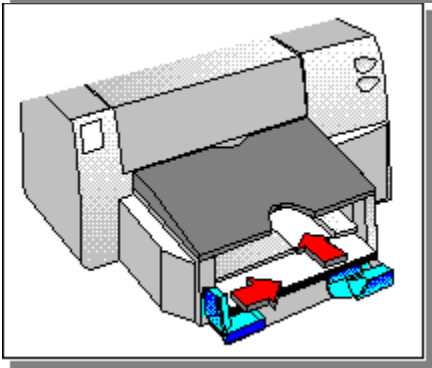
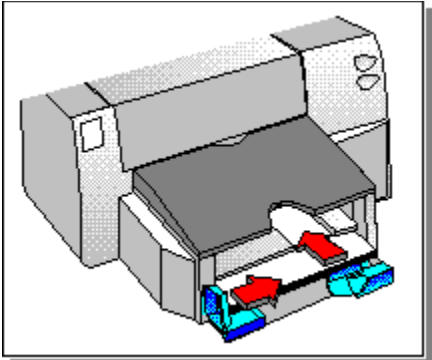

4 Print your document.

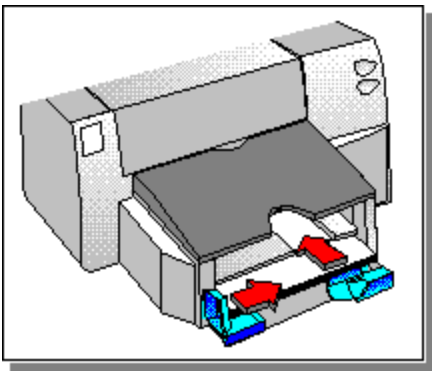

Print on Labels

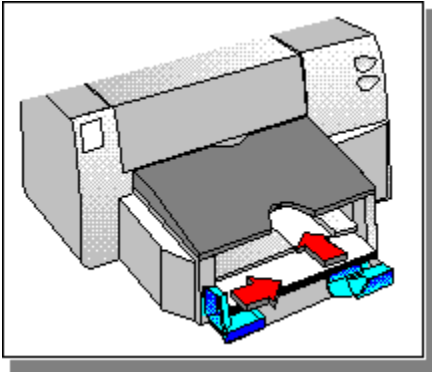

Step 1 of 4

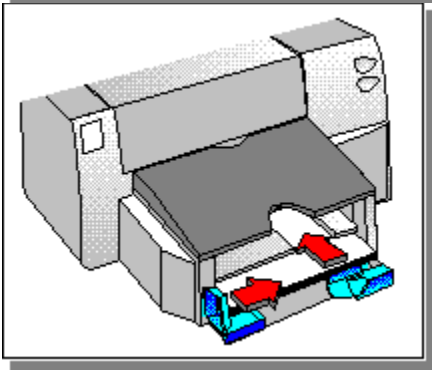
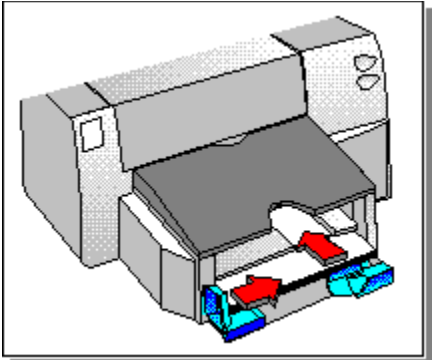

1 Fan a stack of labels to make sure none of the pages are sticking together.

Note: Use only paper labels that are specifically designed for inkjet printers (such as Avery InkJet Labels), and make sure the labels are not over two years old.

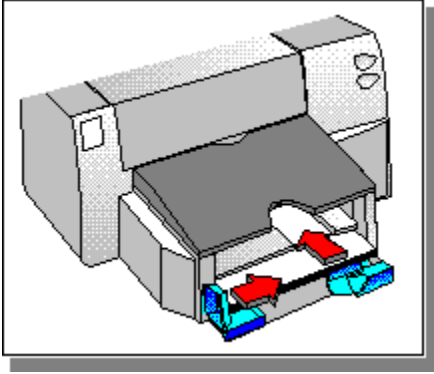

Print on Labels

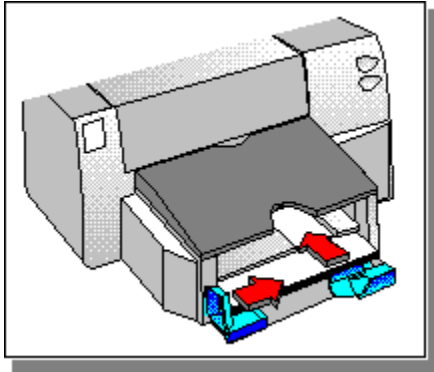

Step 2 of 4

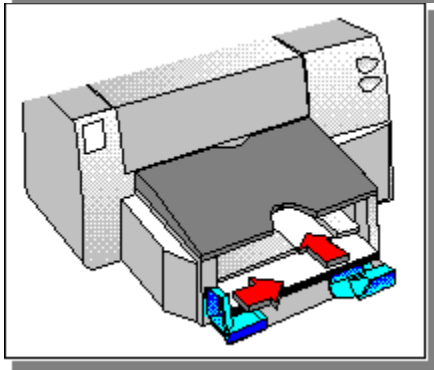
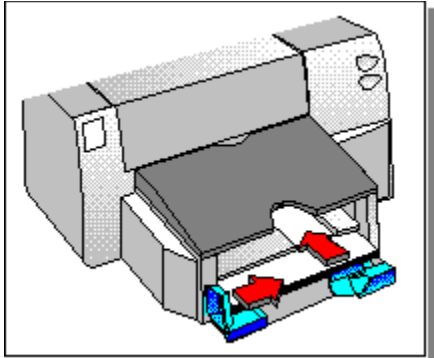

- 2 Slide a stack of labels along the right side of the IN tray, print side down, on top of approximately 25 sheets of plain paper.

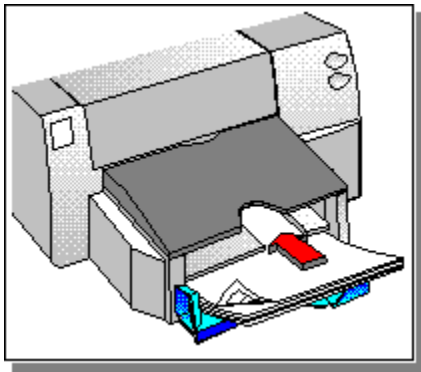

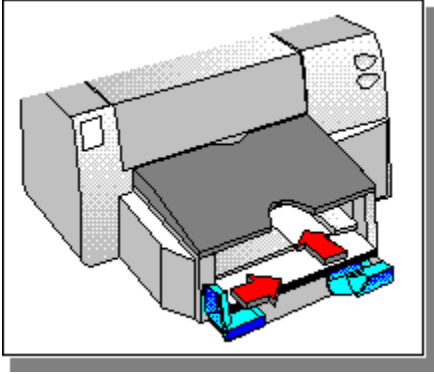

Print on Labels

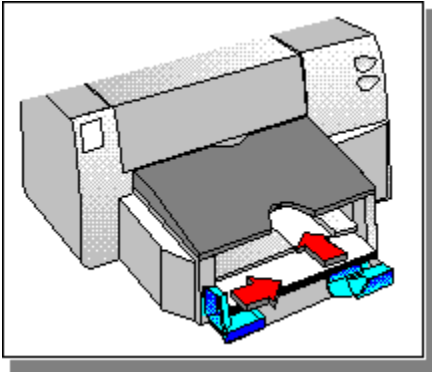

Step 3 of 4

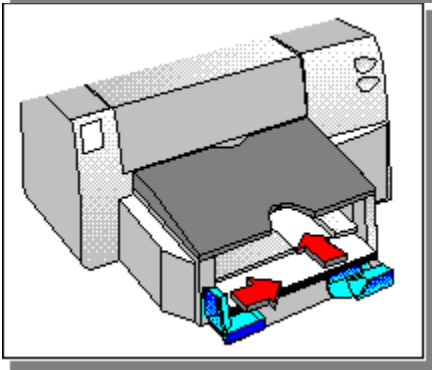
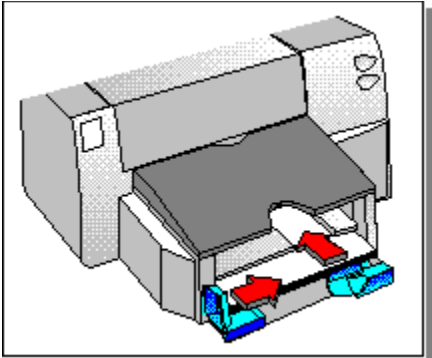

3 Slide the paper width and length adjusters in until they stop at the edges of the labels.

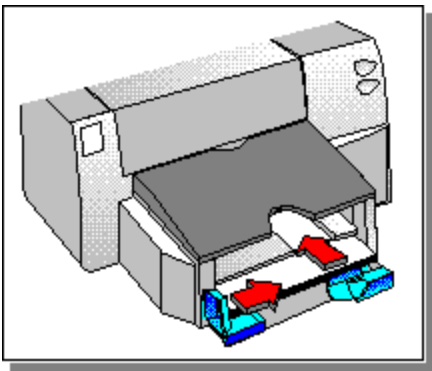

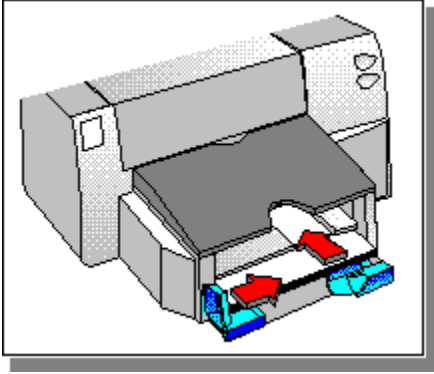

Print on Labels

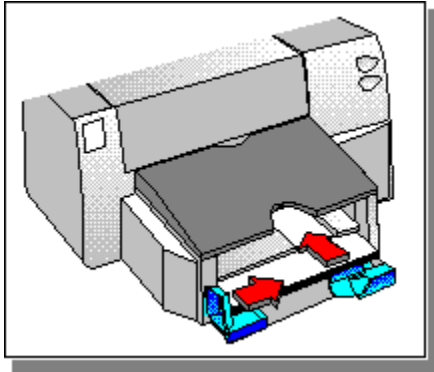

Step 4 of 4

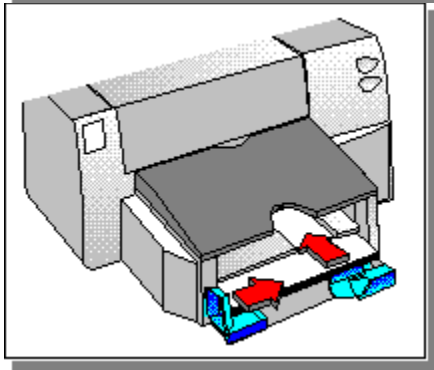
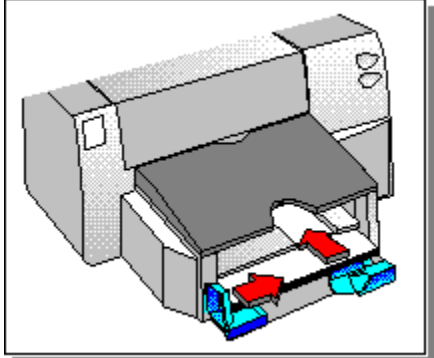

4 Print your labels.

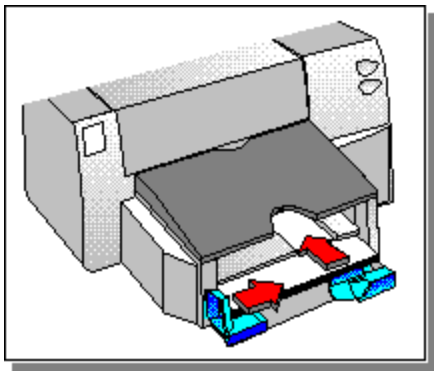

Print on Envelopes Using the IN Tray

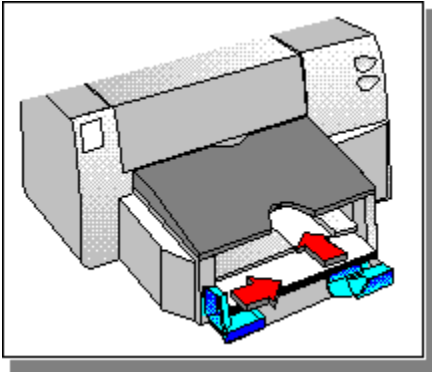

Step 1 of 5

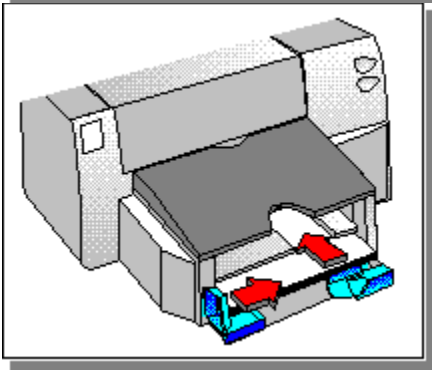
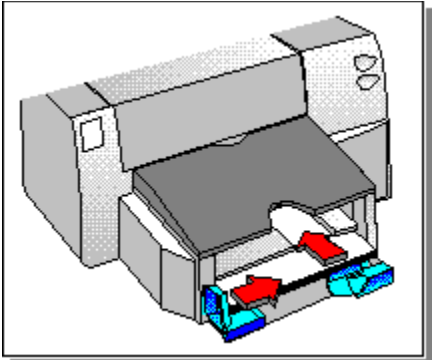

1 Make sure all paper is removed from the IN tray.

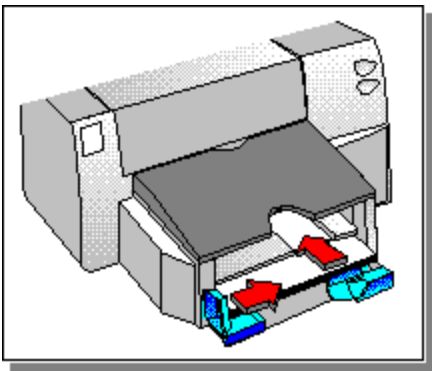

Print on Envelopes Using the IN Tray

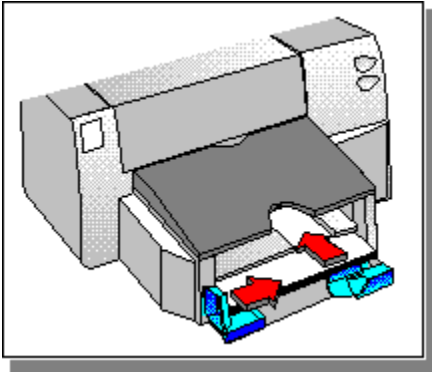

Step 2 of 5

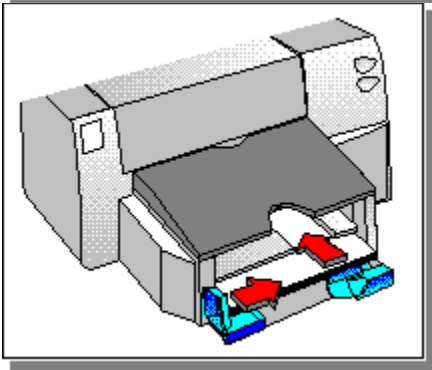
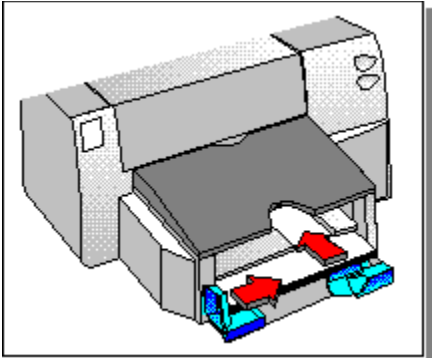

2 Slide the envelopes evenly into the IN tray, with the flaps up and to the right, until they stop.

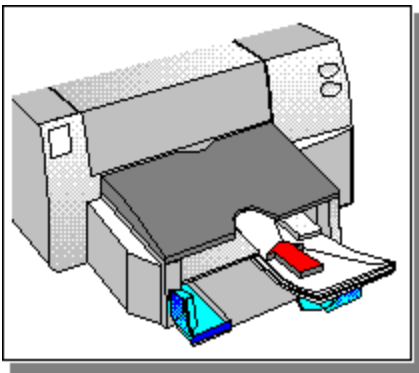

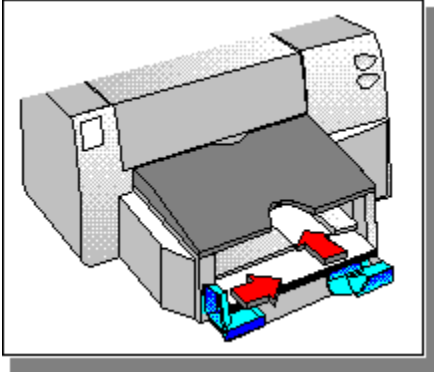

Print on Envelopes Using the IN Tray

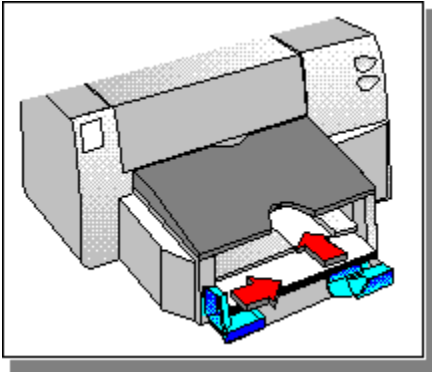

Step 3 of 5

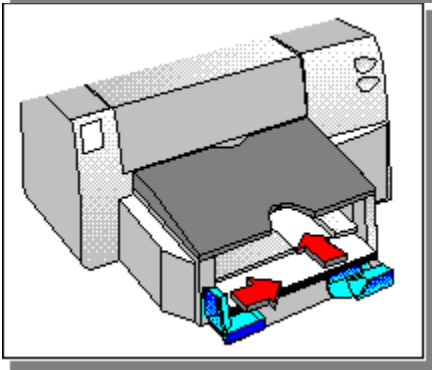
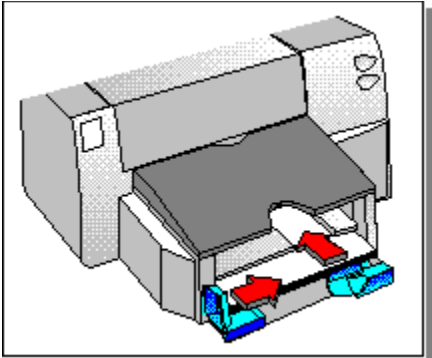

3 Slide the paper width and length adjusters in until they stop at the edges of the envelopes.

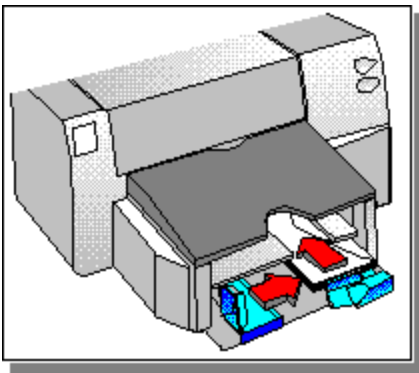

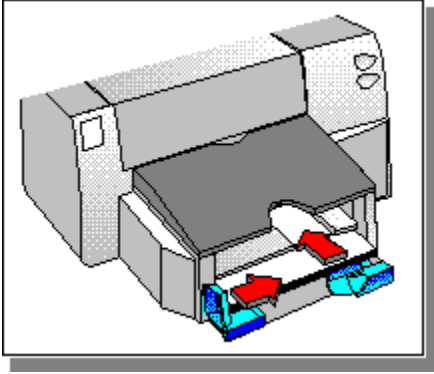

Print on Envelopes Using the IN Tray

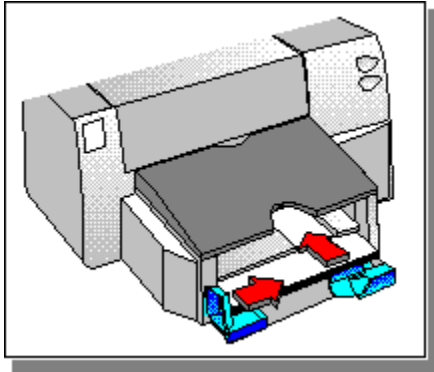

Step 4 of 5

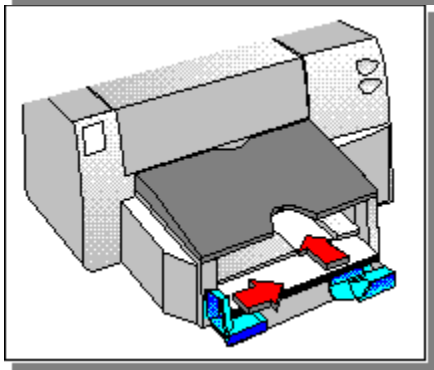
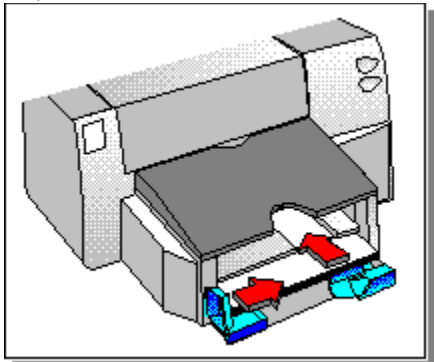

- 4 In HP's print settings dialog box, click the Paper tab. In the Paper Size box, select the size of envelope you are using, and then click OK.

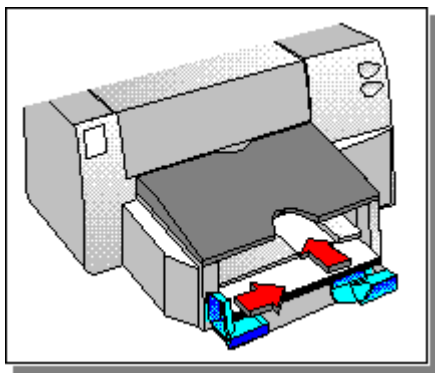

Click here

for instructions on changing print settings.

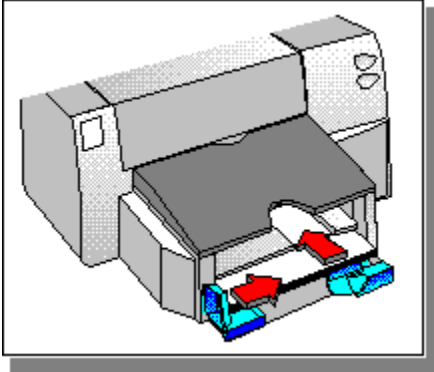

Print on Envelopes Using the IN Tray

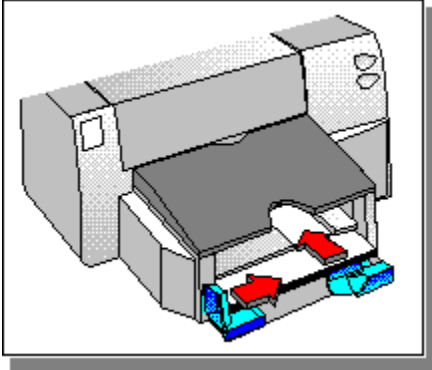

Step 5 of 5

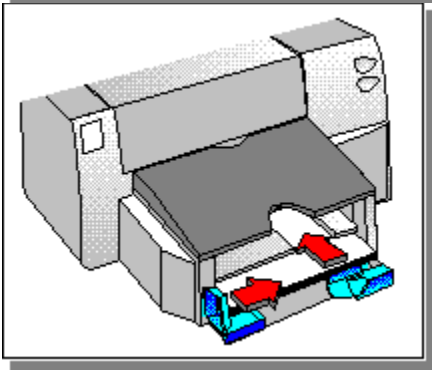
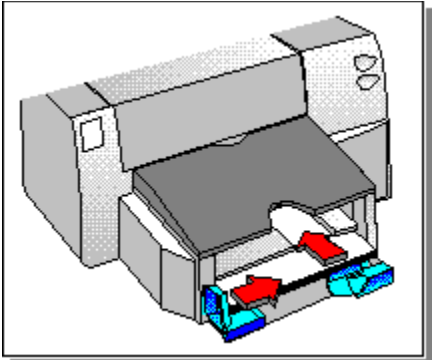

5 Print your envelope.

Build Tags begin here

Replace Print Cartridges

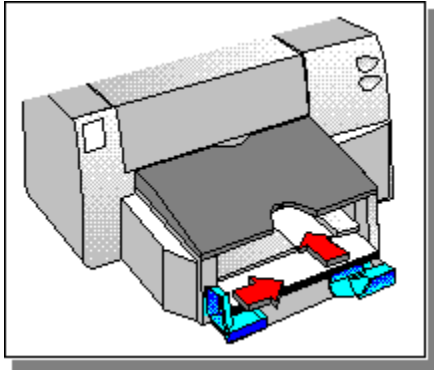

Step 1 of 6

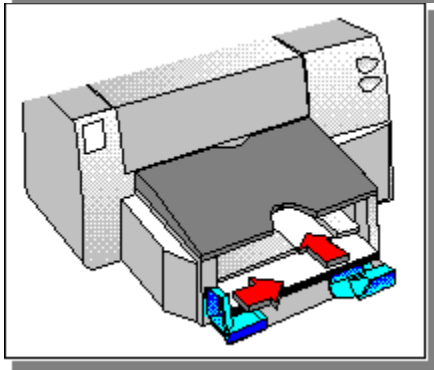
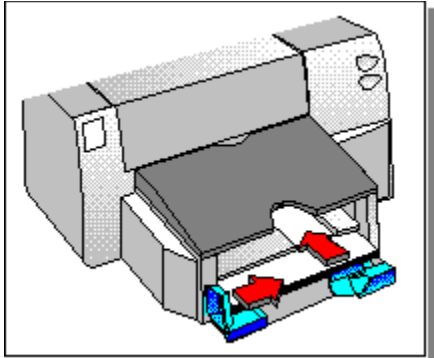

1 Turn on the printer and open the top cover.

The print cartridge cradle moves to the center of the printer, and the Resume light flashes.

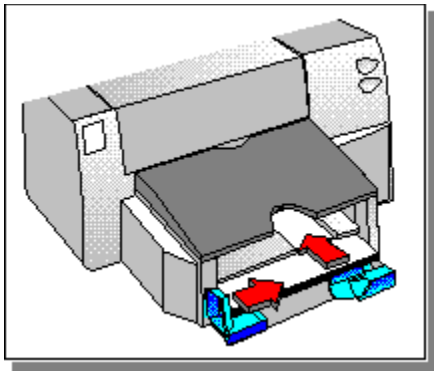

Replace Print Cartridges

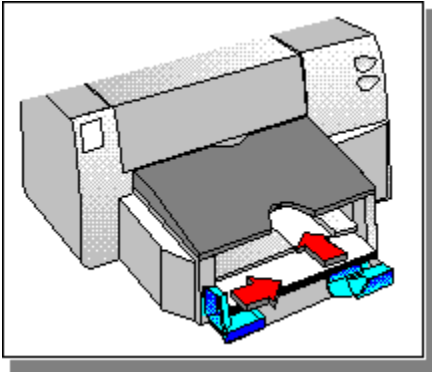

Step 2 of 6

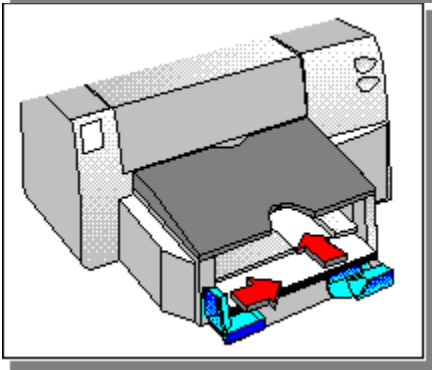
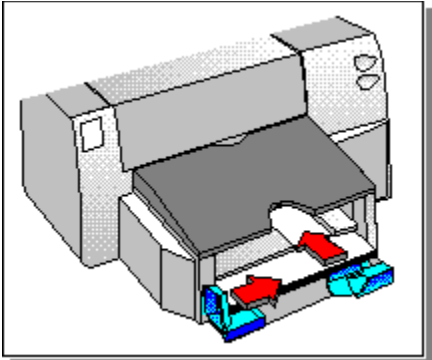

- 2 Flip up the print cartridge latch, grasp the top of the old print cartridge, and pull it up and out of its cradle.

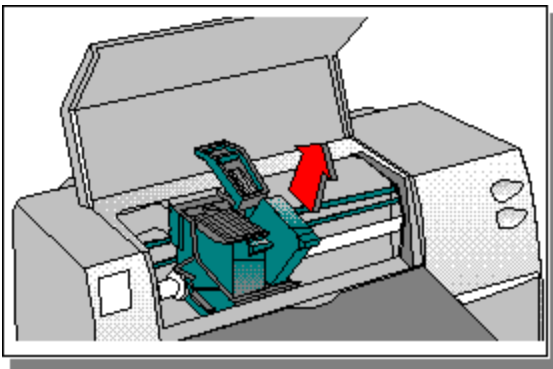

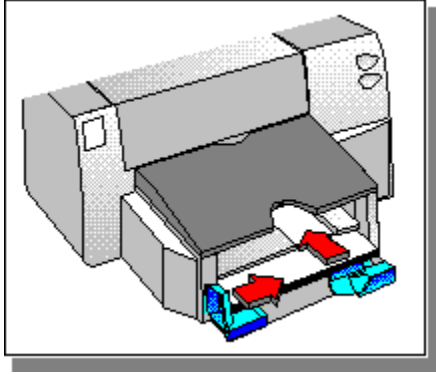

Replace Print Cartridges

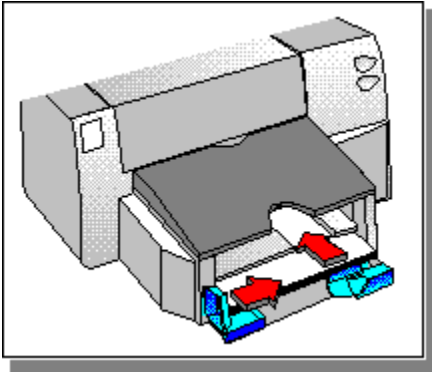

Step 3 of 6

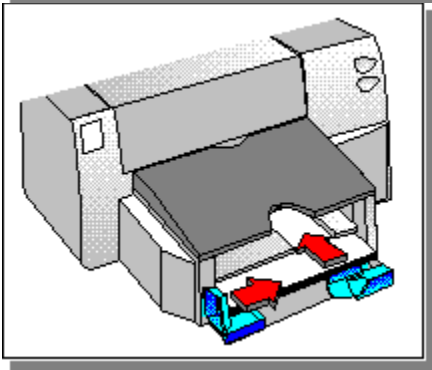
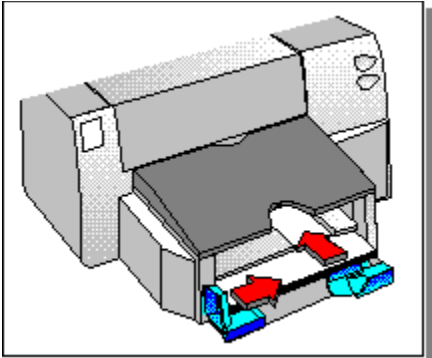

- 3 Remove the new print cartridge from its package, and gently remove any tape covering the ink nozzles, being careful not to touch the ink nozzles or the contacts.

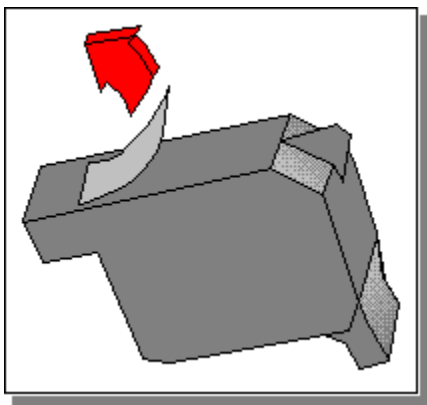

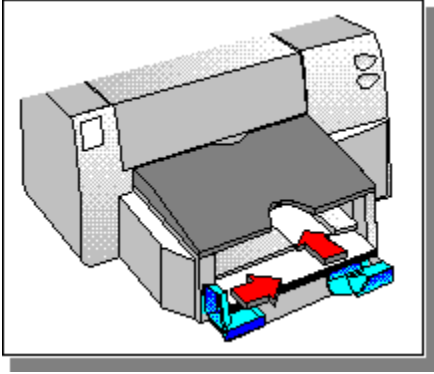

Replace Print Cartridges

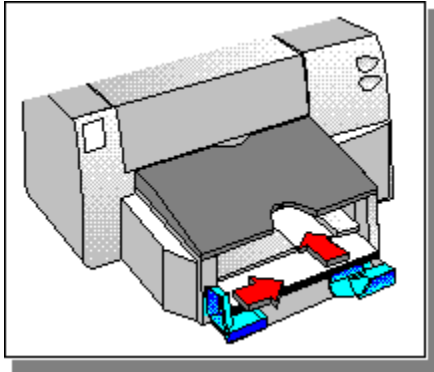

Step 4 of 6

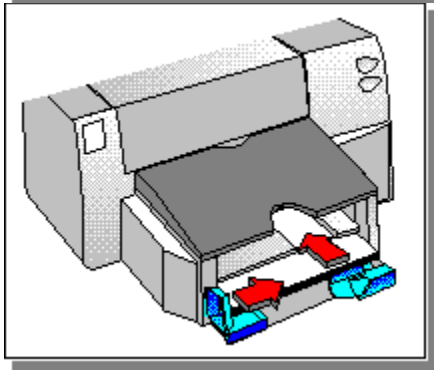
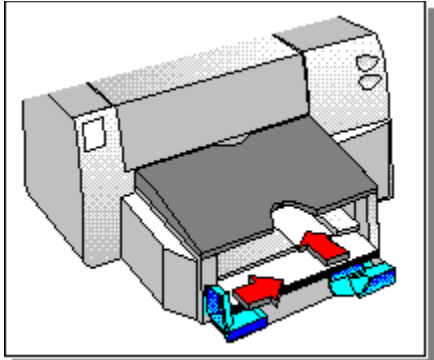

- 4 Push the new cartridge down firmly into its cradle slot, and close the print cartridge latch.

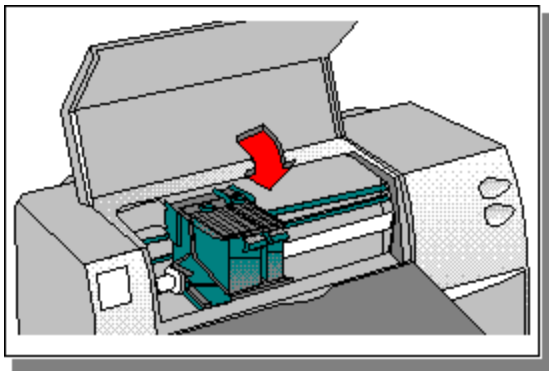

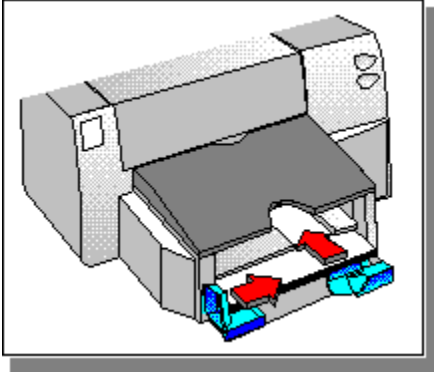

Replace Print Cartridges

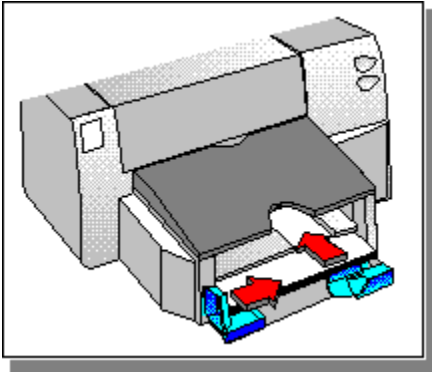

Step 5 of 6

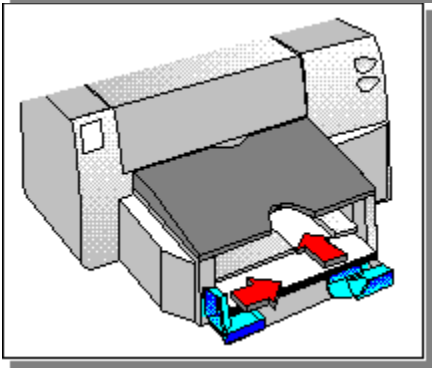
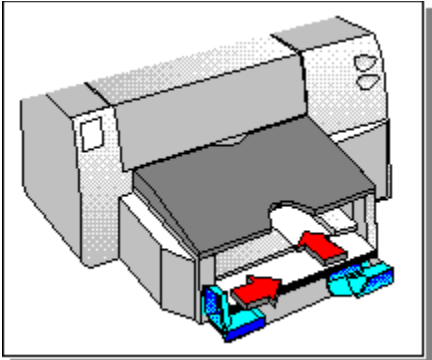

5 Close the printer's top cover.

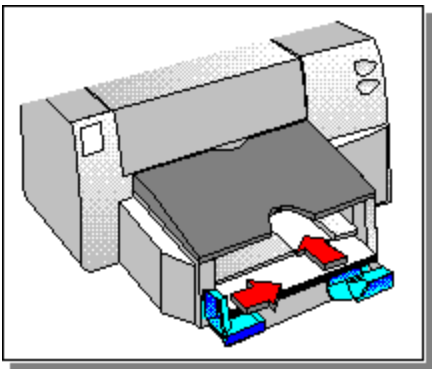

Replace Print Cartridges

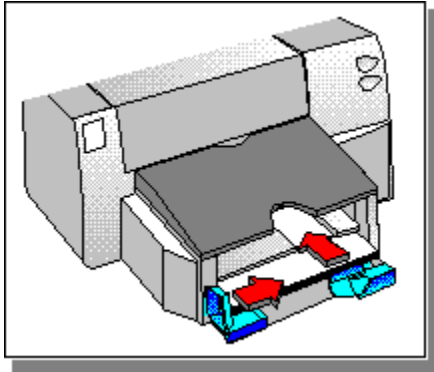

Step 6 of 6

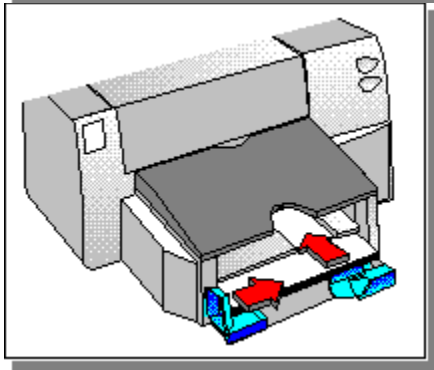
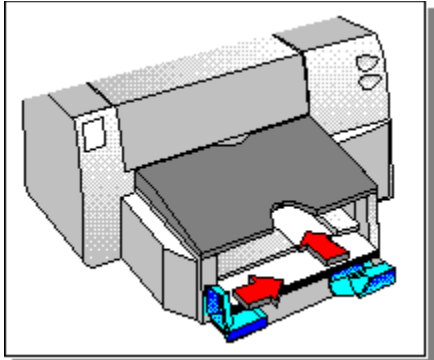

6 Align the print cartridges for best print quality.

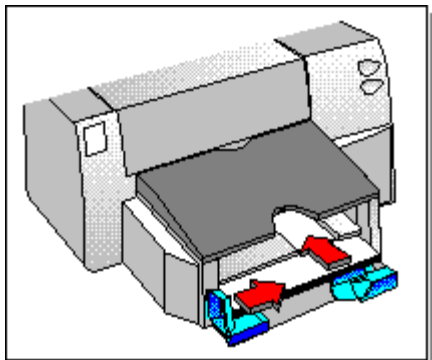

Click here

to align the print cartridges now.

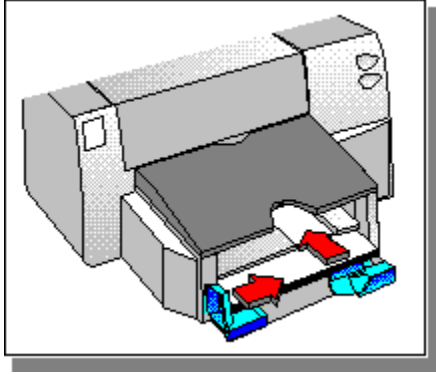

Build tag spacer 1

Print on Custom-Sized Paper

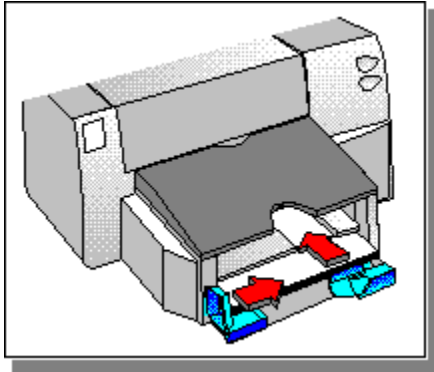

Step 1 of 5

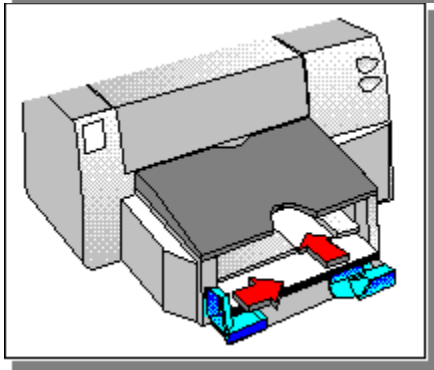
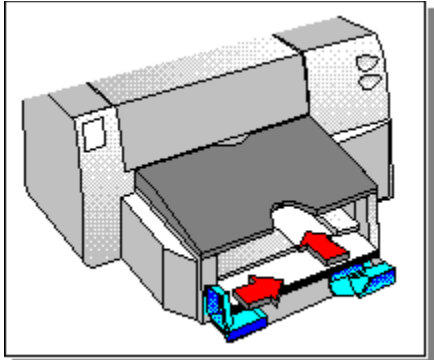

- 1 In [HP's print settings dialog box](#), click the Paper tab. In the Paper Size box, select Custom. The Custom Paper Size dialog box appears.

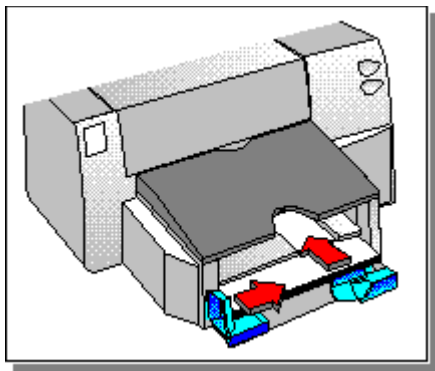

Click here

[for instructions on changing print settings.](#)

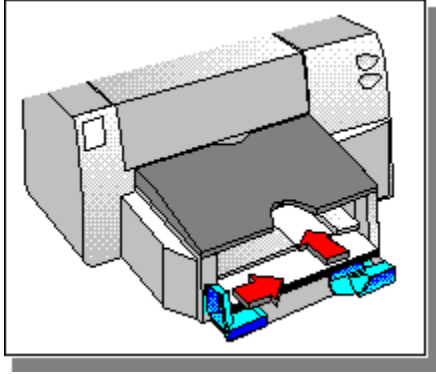

Print on Custom-Sized Paper

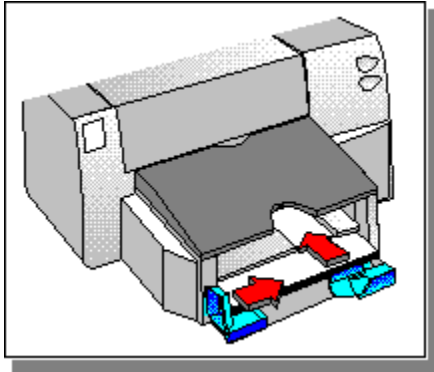

Step 2 of 5

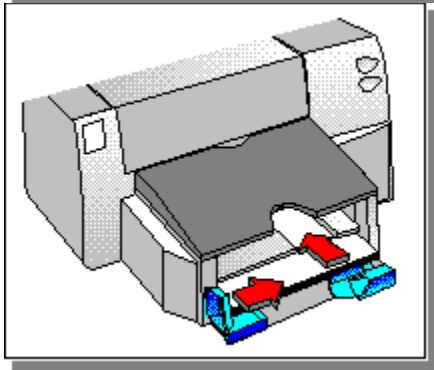
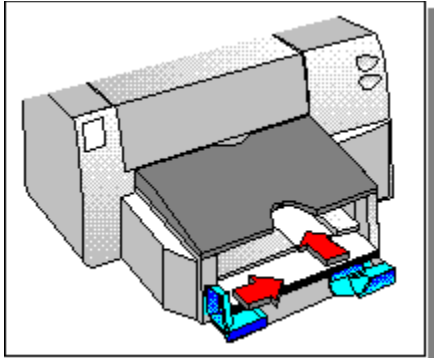

2 Under Paper Size, type values in the Width and Length boxes, and then click OK.

Note The paper width must be between 3.9 inches and 8.5 inches (100 mm and 215 mm); the paper length must be between 5.8 inches and 14 inches (148 mm and 356 mm).

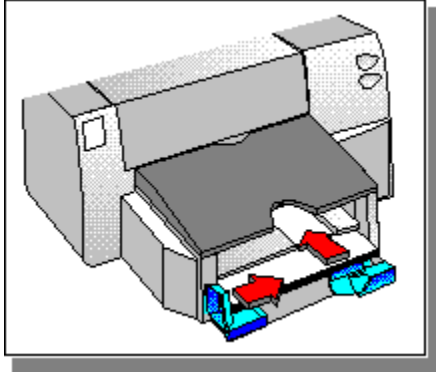

Print on Custom-Sized Paper

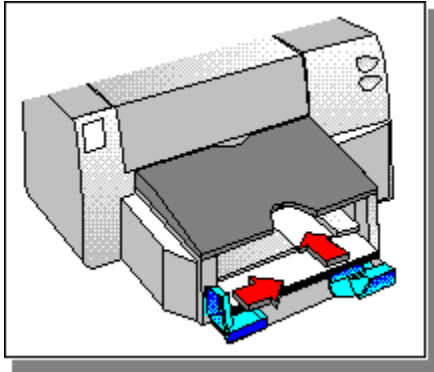

Step 3 of 5

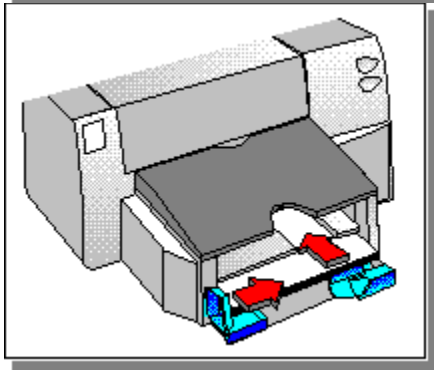
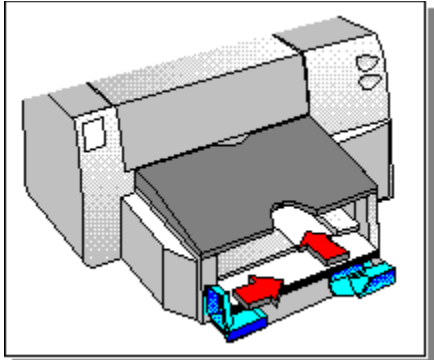

3 Insert up to a 3/4 inch (19 mm) stack of paper along the right side of the IN tray, print side down, until it stops.

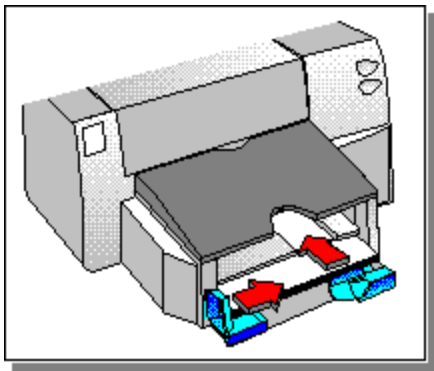

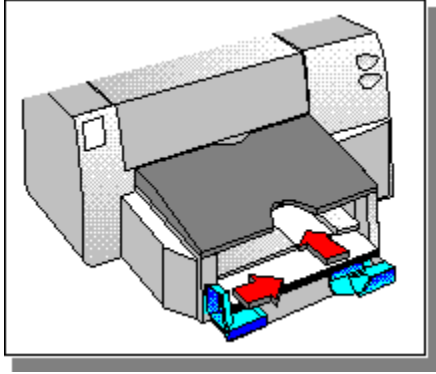

Print on Custom-Sized Paper

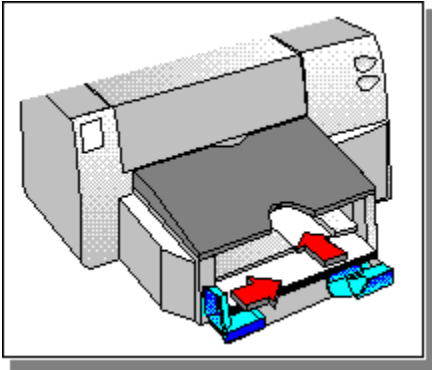

Step 4 of 5

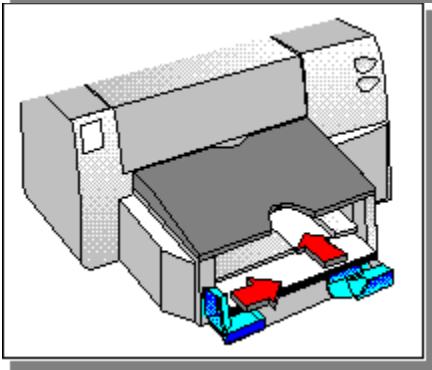
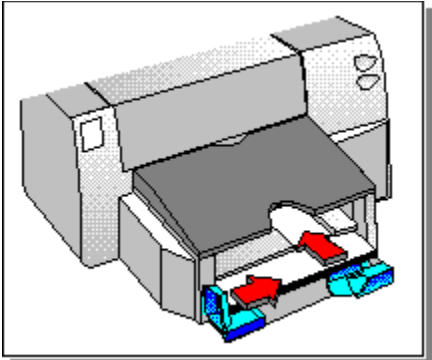

- 4 Slide the paper width and length adjusters in until they stop at the edges of the paper.

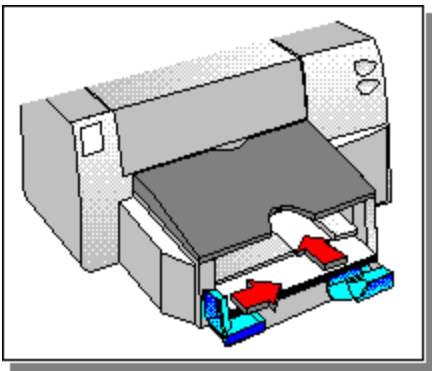

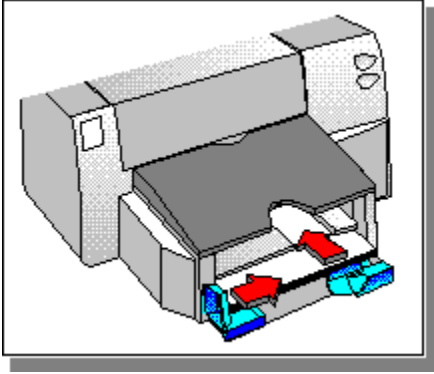

Print on Custom-Sized Paper

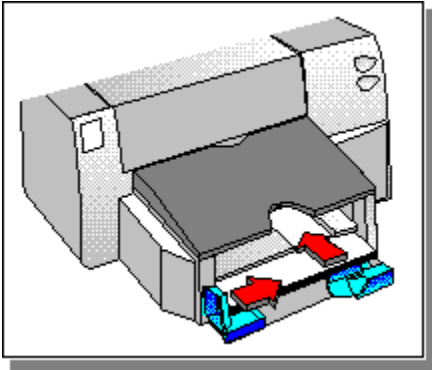

Step 5 of 5

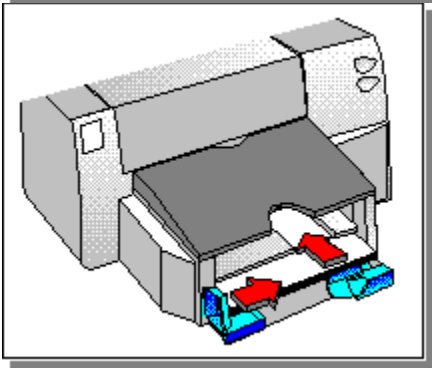
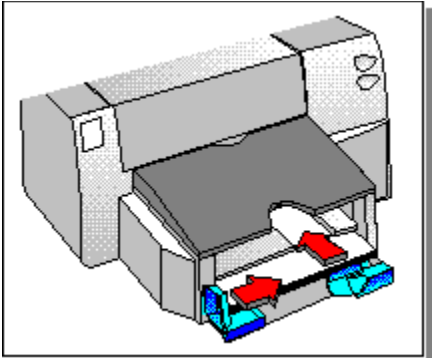

5 Print your document.

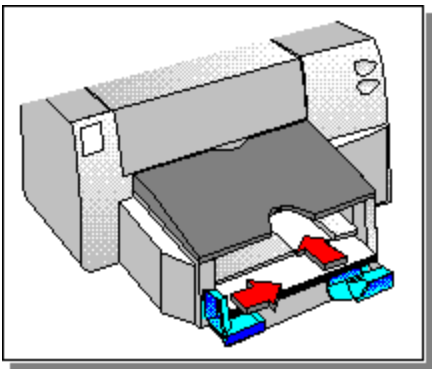

Build tag spacer 2

Build tag spacer 3

Build tag spacer 4

Print on Envelopes

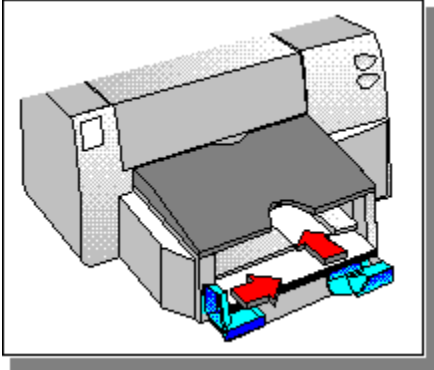

You can print single envelopes using the single-envelope slot, or you can print up to 20 envelopes using the IN tray. Select the method you want to use:

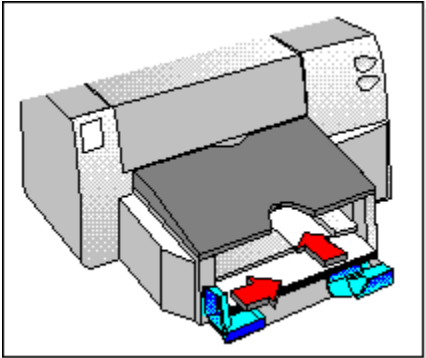

Single envelope

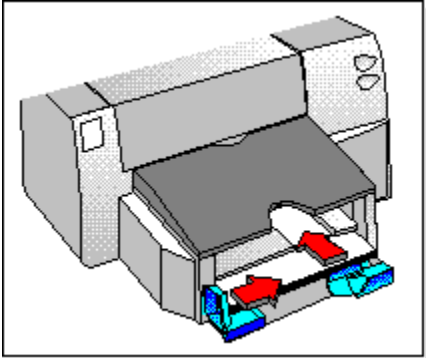

Multiple envelopes

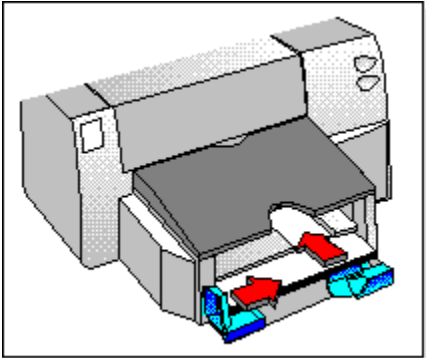

Build tag spacer 5

Print on Cards

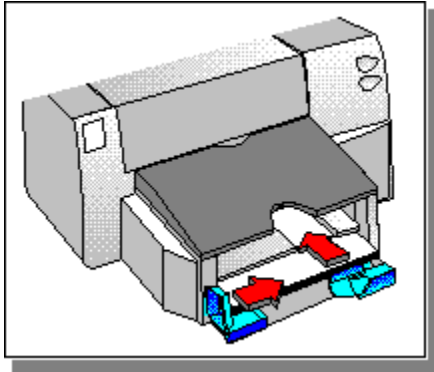

Step 1 of 4

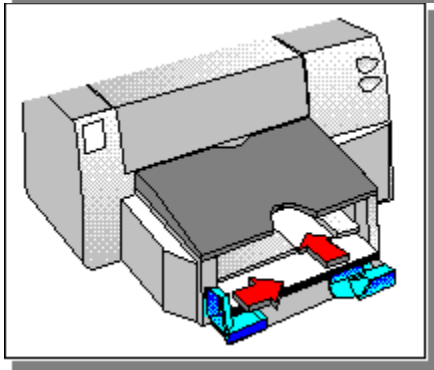
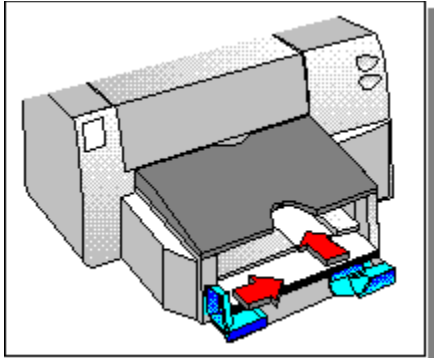

- 1 Insert up to a 3/4 inch (19 mm) stack of cards along the right side of the IN tray, with the print side down and the short edge at front, until it stops.

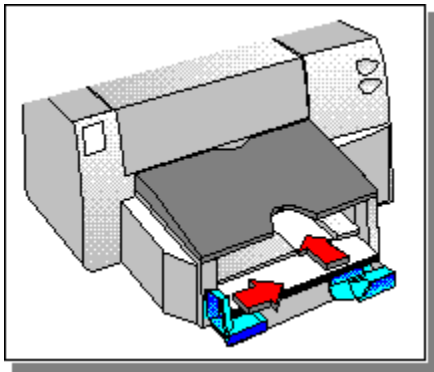

Print on Cards

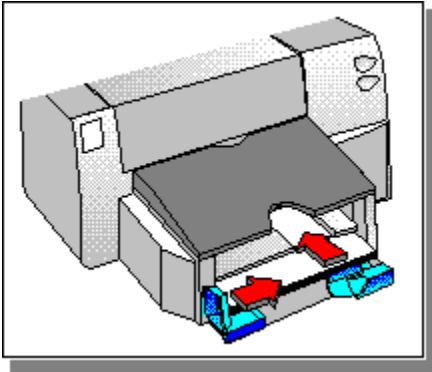

Step 2 of 4

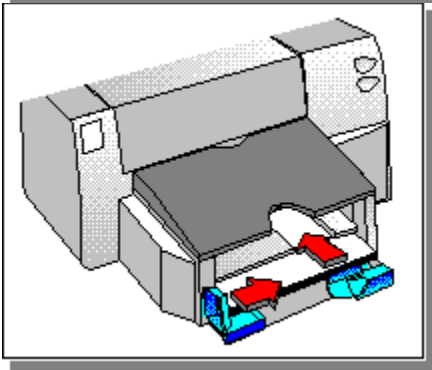
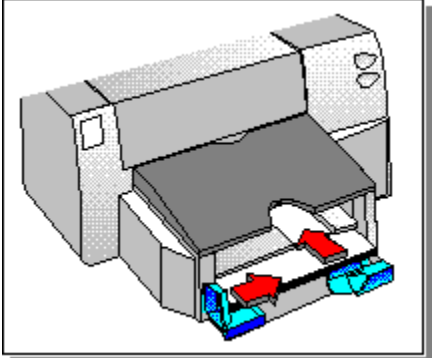

2 Slide the paper width and length adjusters in until they stop at the edges of the cards.

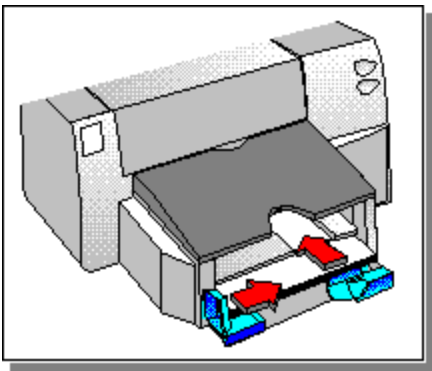

Print on Cards

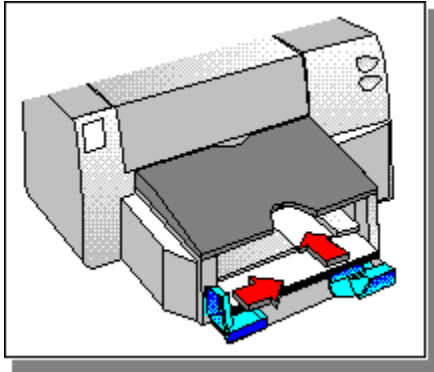

Step 3 of 4

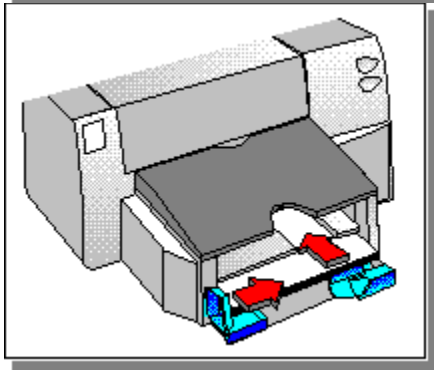
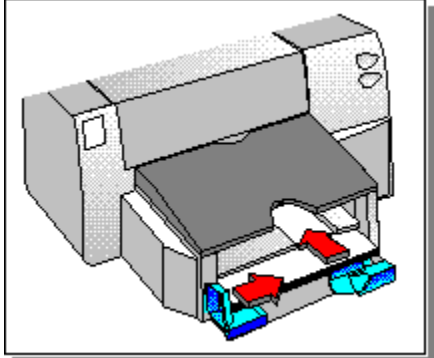

- 3 In HP's print settings dialog box, click the Paper tab. In the Paper Size box, select the size of the cards you are printing, and then click OK; or, select Custom if none of the sizes match the card size you are printing.

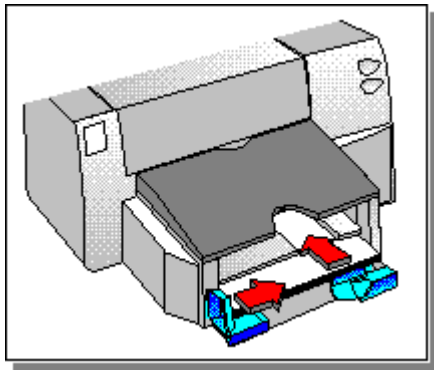

Click here

for instructions on changing print settings.

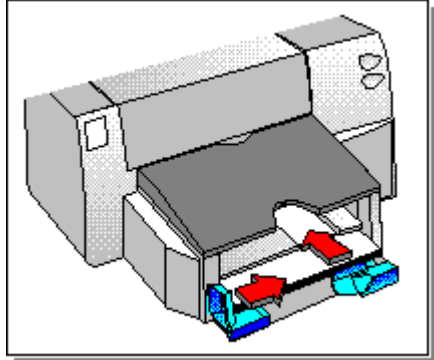

Click here

for instructions on printing on custom-sized paper.

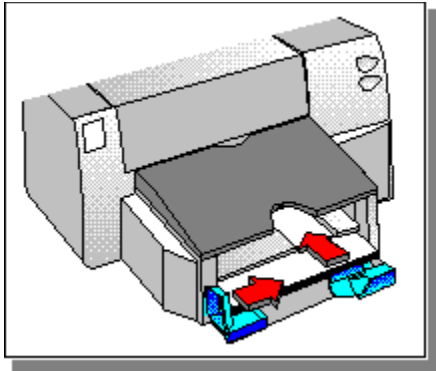

Print on Cards

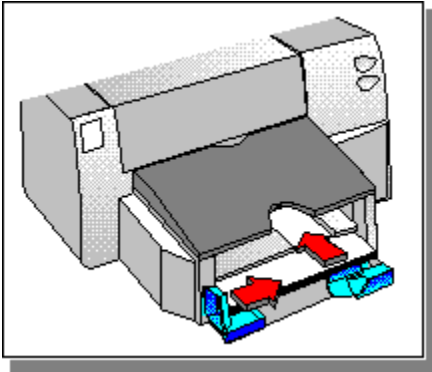

Step 4 of 4

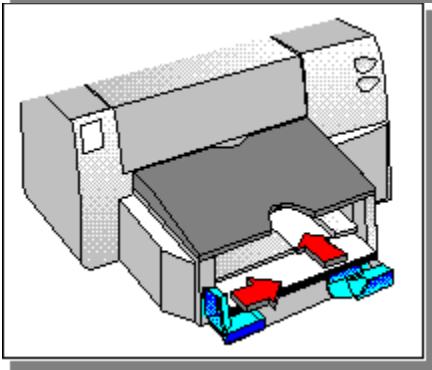
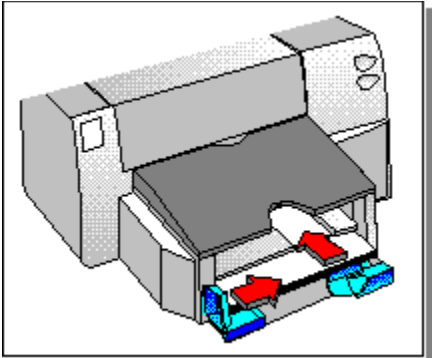

4 Print your cards.

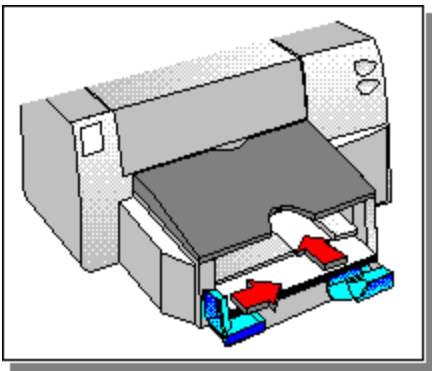

Build tag spacer 6

Print on Standard-Sized Paper

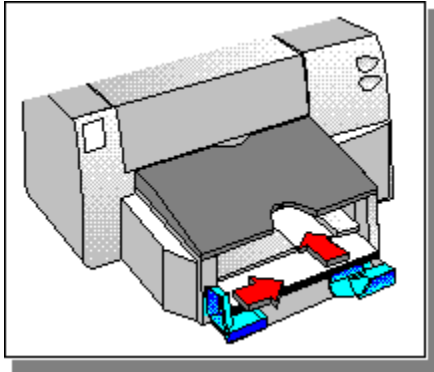

Step 1 of 4

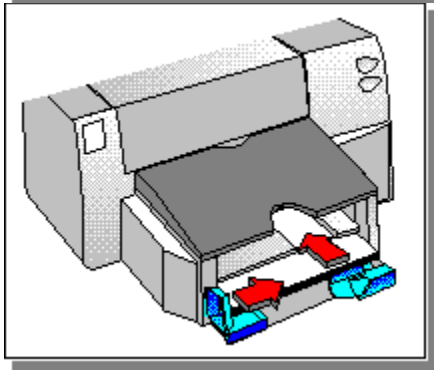
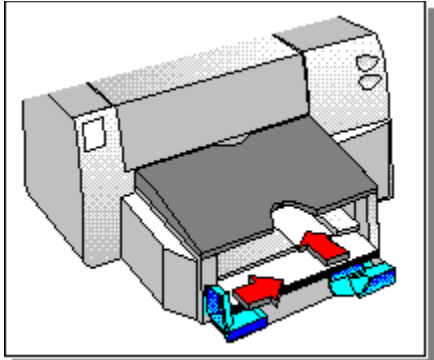

- 1 Insert up to a 3/4 inch (19 mm) stack of paper along the right side of the IN tray, print side down, until it stops.

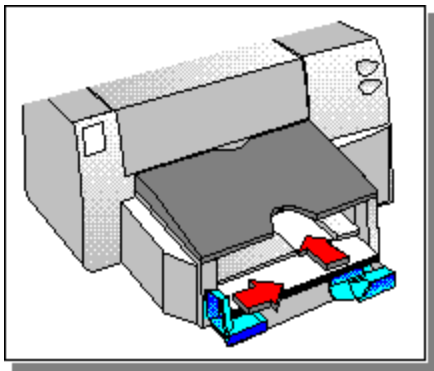

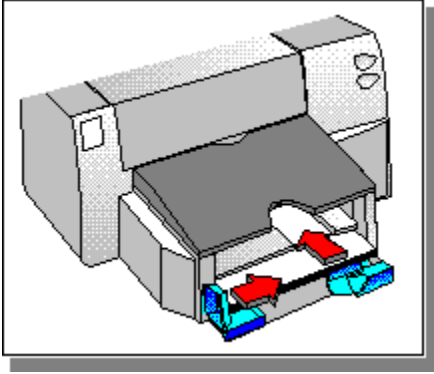

Print on Standard-Sized Paper

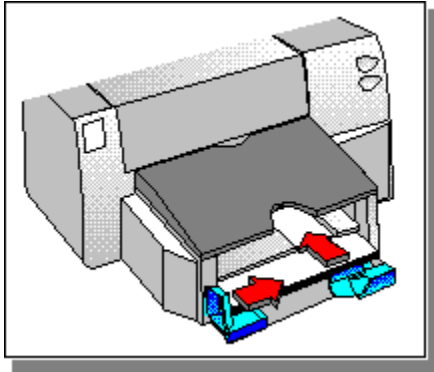

Step 2 of 4

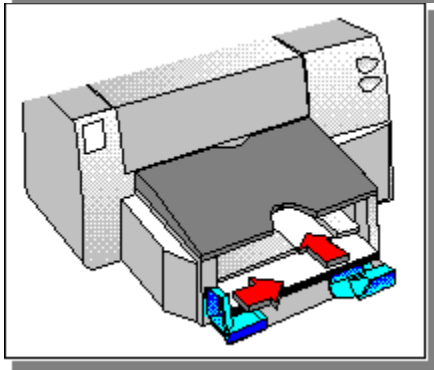
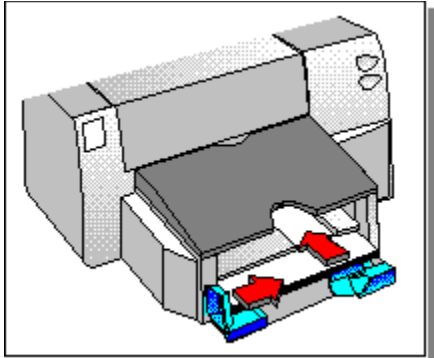

2 Slide the paper width and length adjusters in until they stop at the edges of the paper.

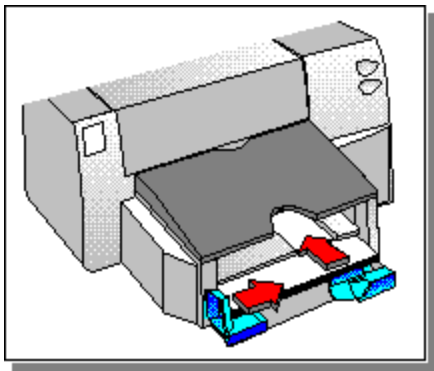

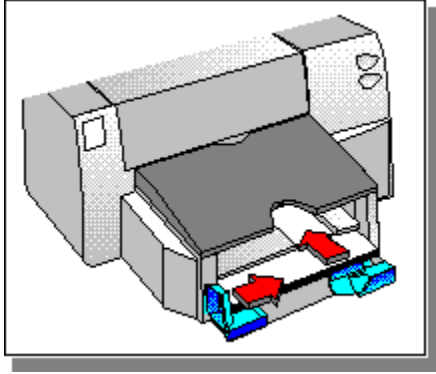

Print on Standard-Sized Paper

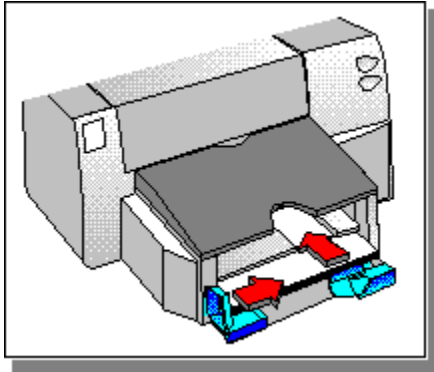

Step 3 of 4

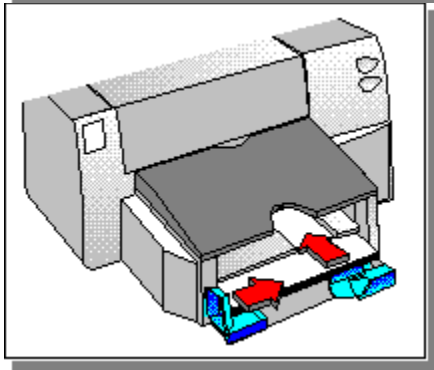
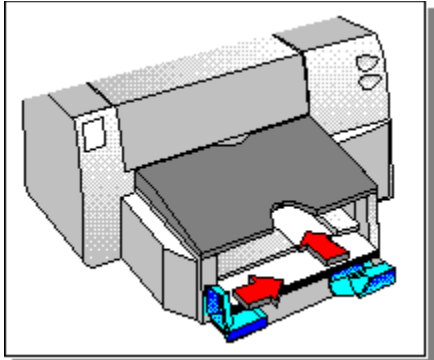

3 In HP's print settings dialog box, change the necessary print settings, and then click OK.

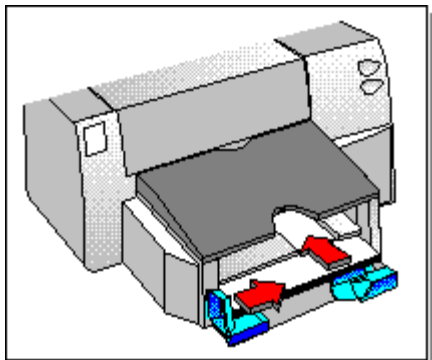

Click here

for instructions on changing print settings.

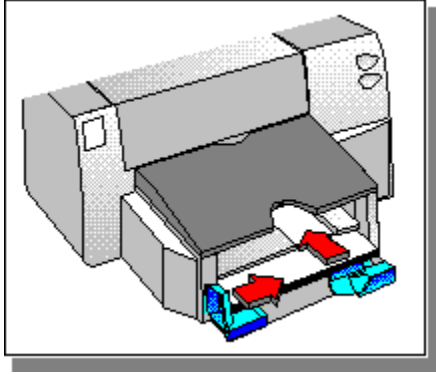

Print on Standard-Sized Paper

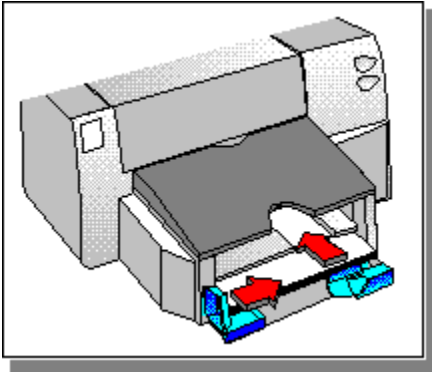

Step 4 of 4

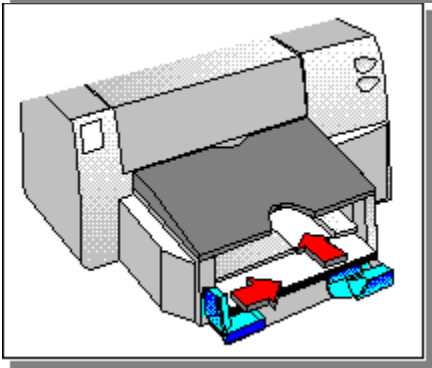
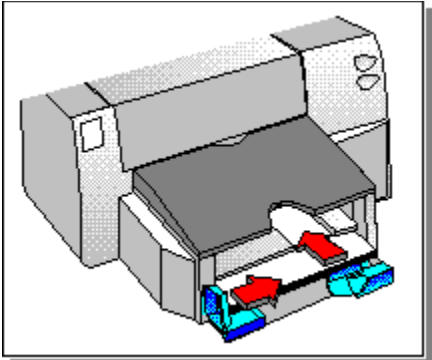

4 Print your document.

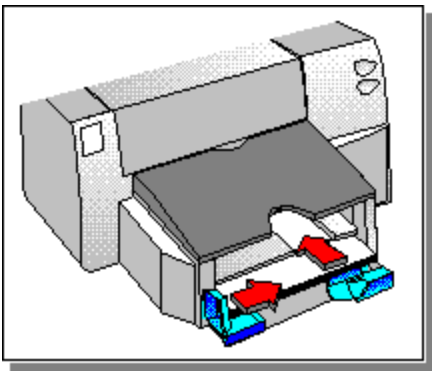

Build tag spacer 7

Clear a Paper Jam

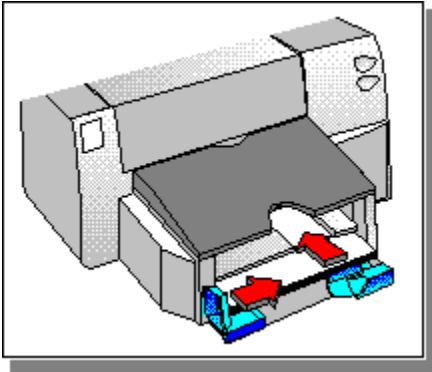

Step 1 of 5

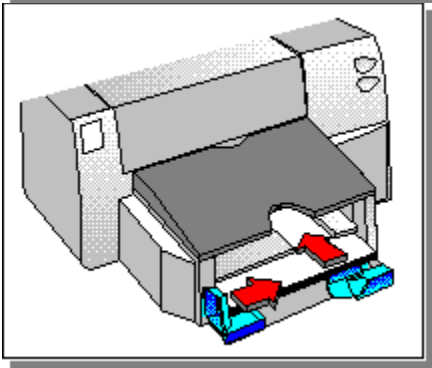
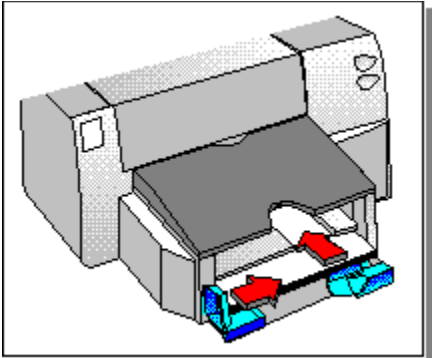

1 Open the printer's top cover.

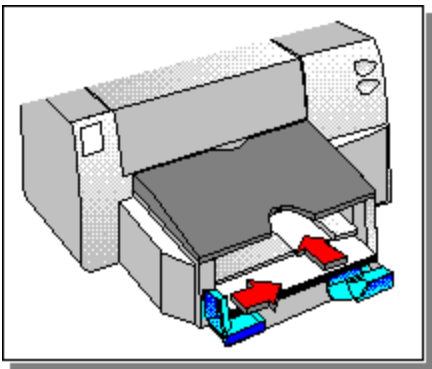

Clear a Paper Jam

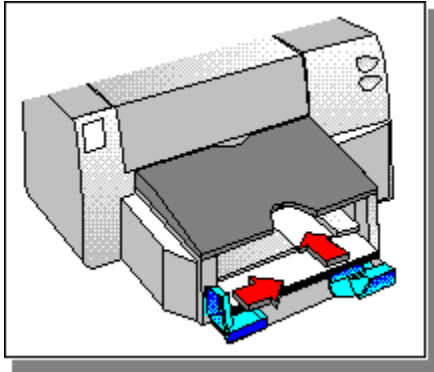

Step 2 of 5

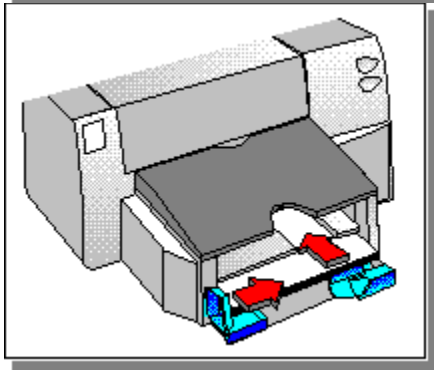
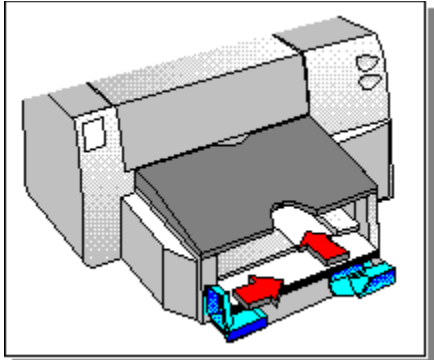

- 2 Press and hold down the Resume  button.
The paper will move in one direction.

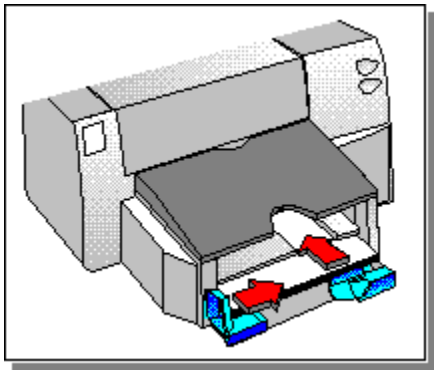

Clear a Paper Jam

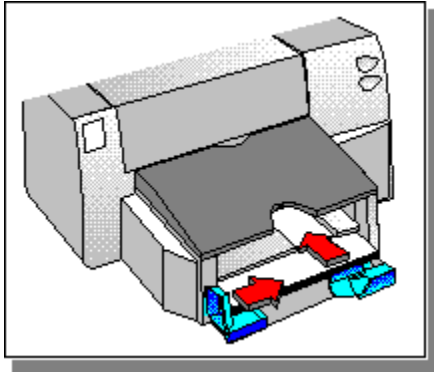

Step 3 of 5

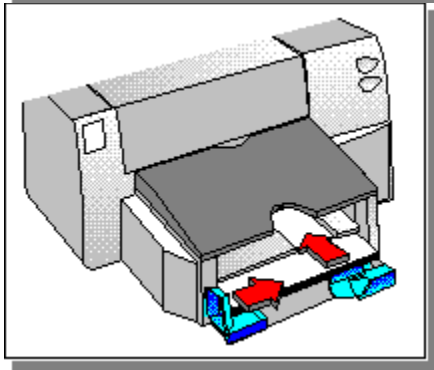
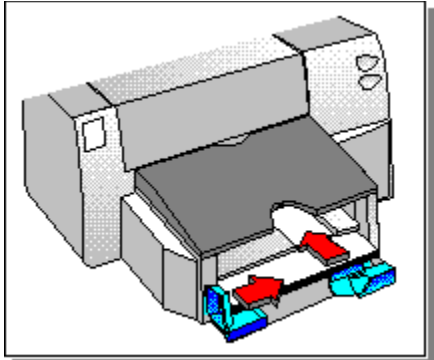

3 If necessary, remove the IN tray to remove any wrinkled and torn paper. Replace the IN tray and load new paper.

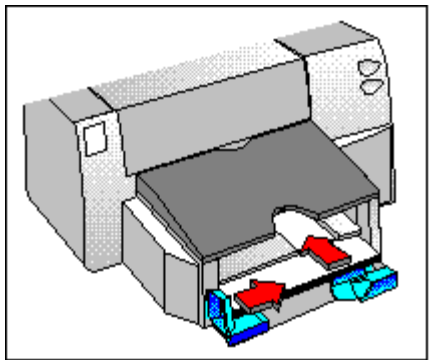

Click here

for instructions on loading paper.

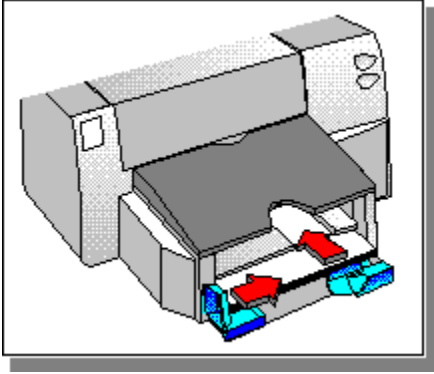

Clear a Paper Jam

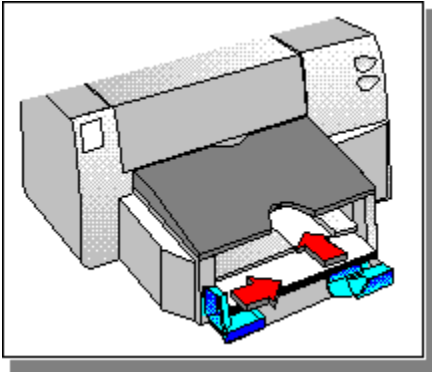

Step 4 of 5

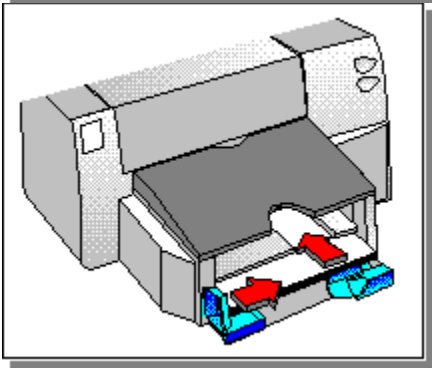
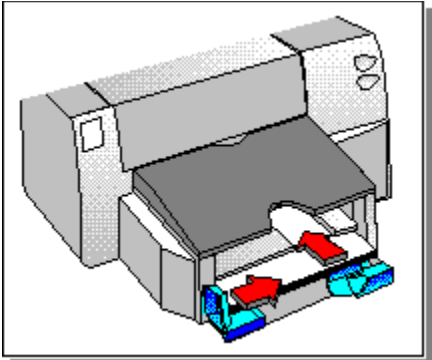

4 Close the printer's top cover.

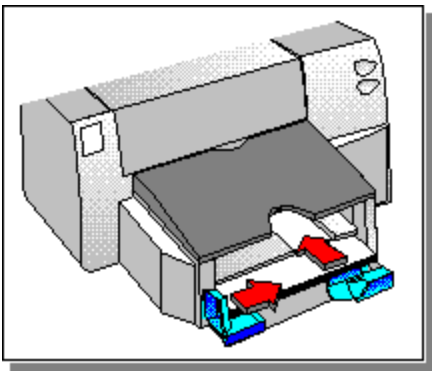

Clear a Paper Jam

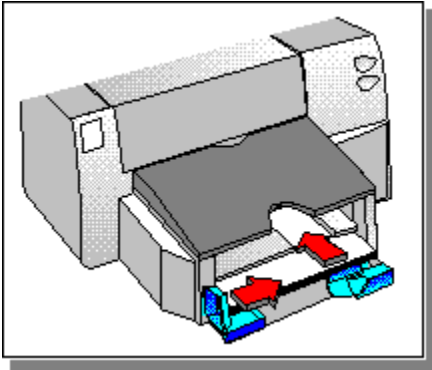

Step 5 of 5

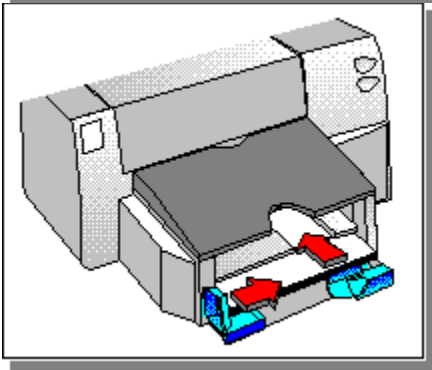
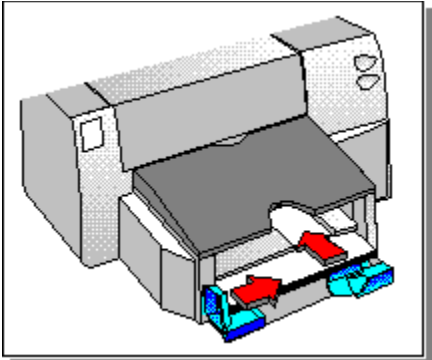

5 Turn the printer off, and then turn it back on.

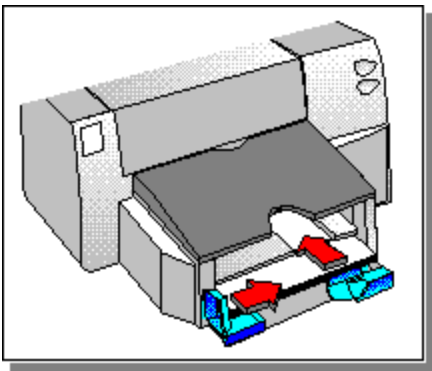

Build tag spacer 8

Build tag spacer 9

Build tag spacer 10

Print on Envelopes Using the Single-envelope Slot

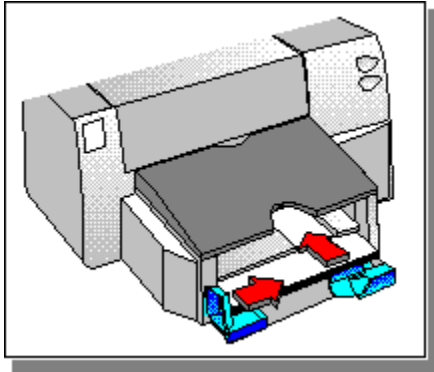

Step 1 of 3

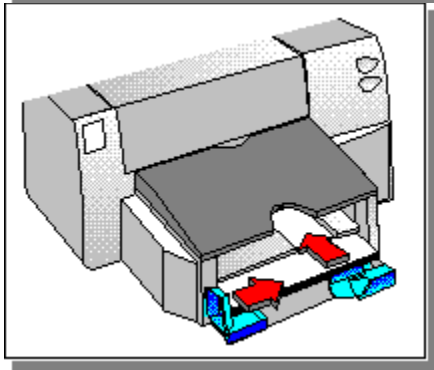
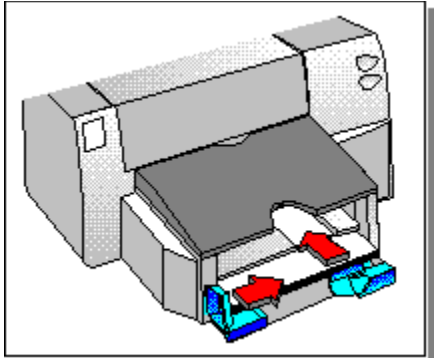

- 1 Slide the envelope evenly into the single-envelope slot, with the flap up and to the right, until it stops.

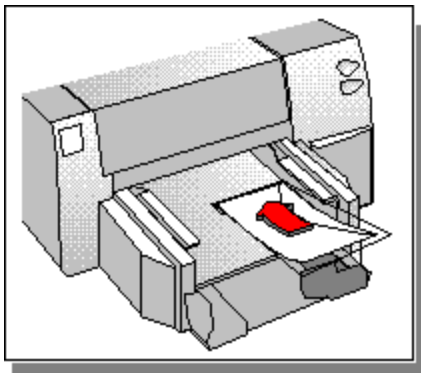

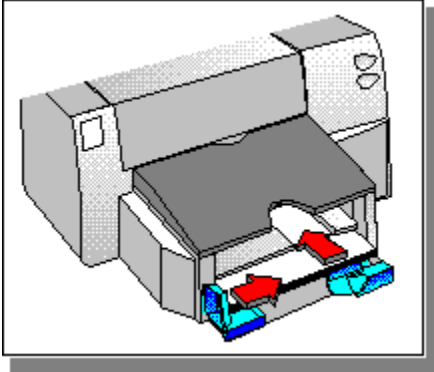

Print on Envelopes Using the Single-envelope Slot

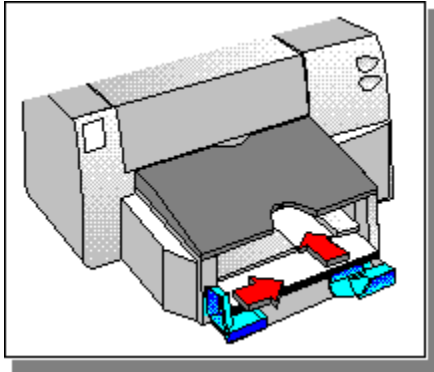

Step 2 of 3

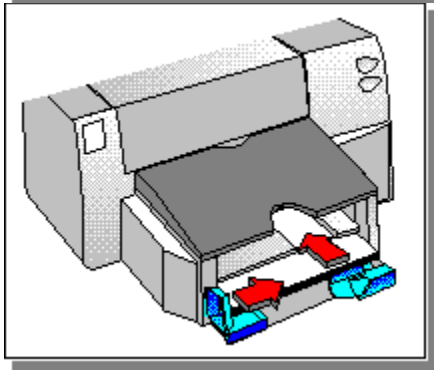
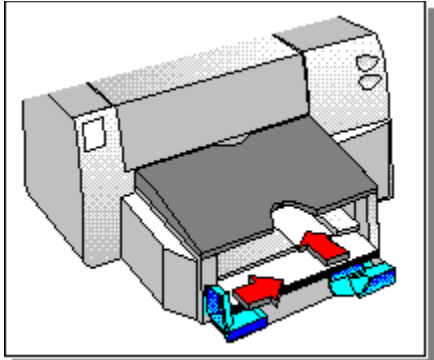

- 2 In HP's print settings dialog box, click the Paper tab. In the Paper Size box, select the size of envelope you are using, and then click OK.

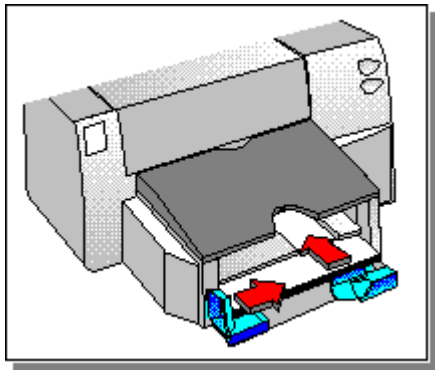

Click here

for instructions on changing print settings.

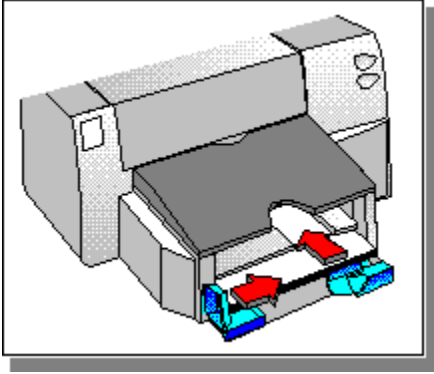

Print on Envelopes Using the Single-envelope Slot

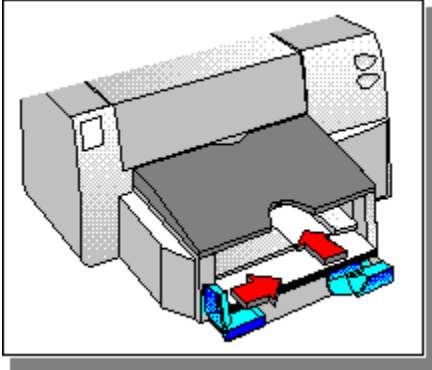

Step 3 of 3

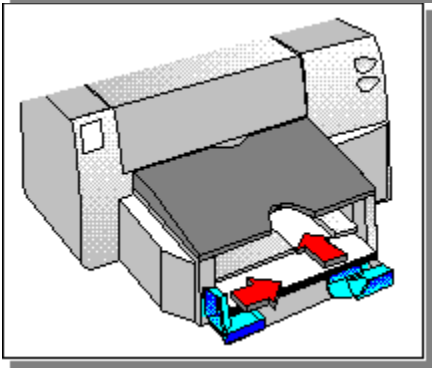
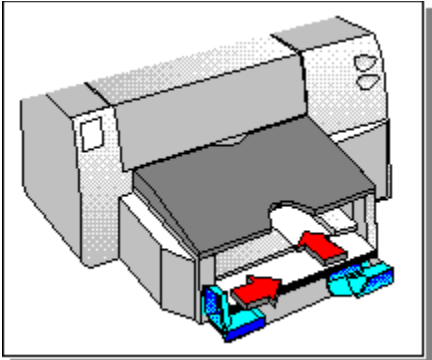

3 Print your envelope.

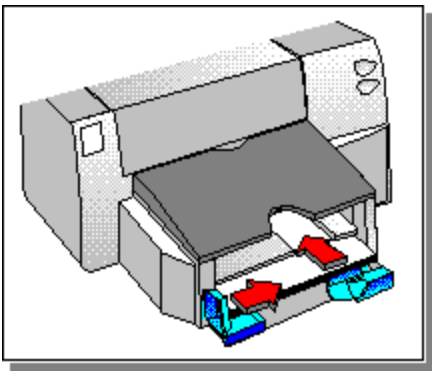

Build tag spacer 11

Build tag spacer 12

Build tag spacer 13

Build tag spacer 14

Build tag spacer 15

Select a Default Printer

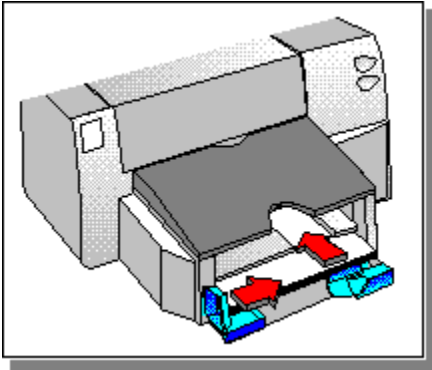

Step 1 of 3

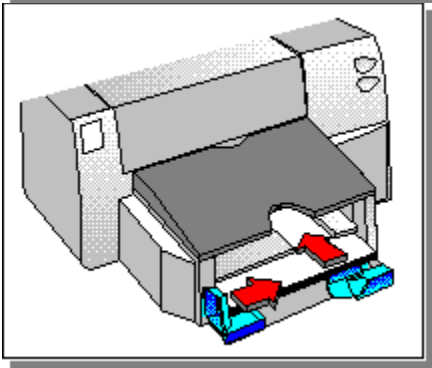
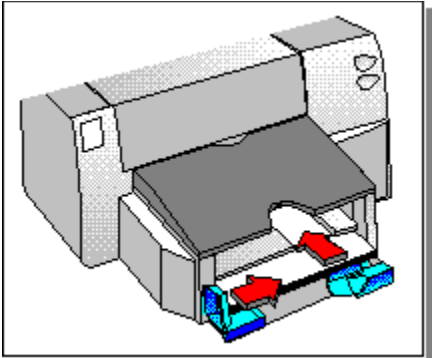

1 On the task bar, click Start, and then select Printers from the Settings menu.

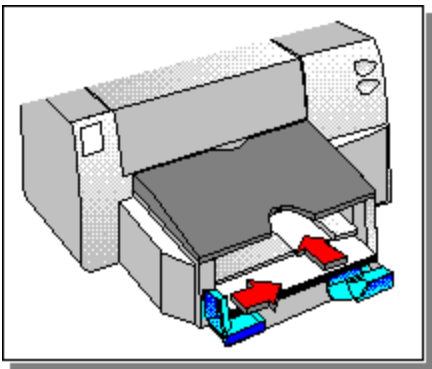

Select a Default Printer

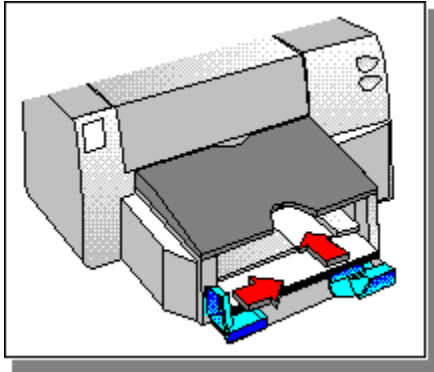

Step 2 of 3

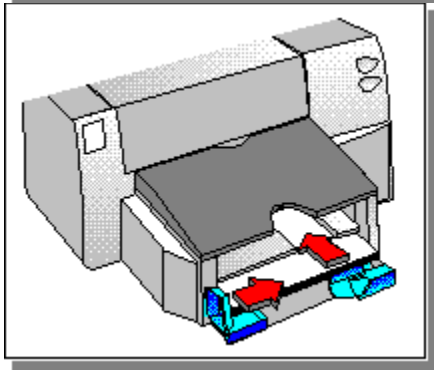
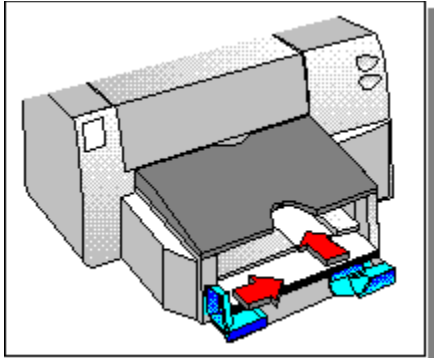

- 2 Click the icon for your HP DeskJet printer, and then select Set As Default from the File menu.
If Set As Default has a check next to it, your printer is already the default printer.

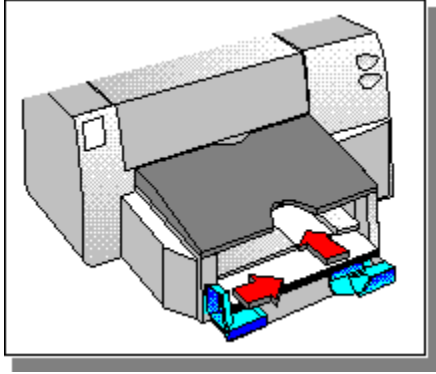

Select a Default Printer

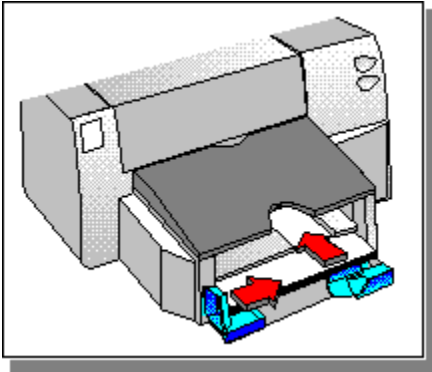

Step 3 of 3

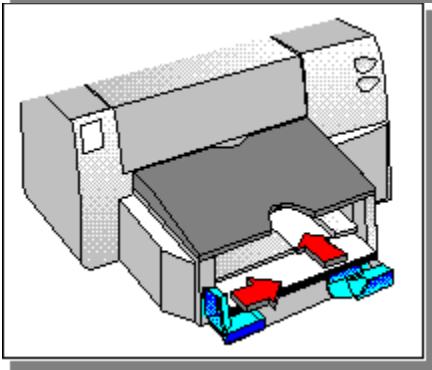
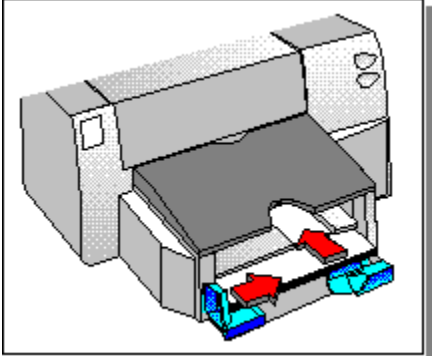

3 Click the Close box to close the window.

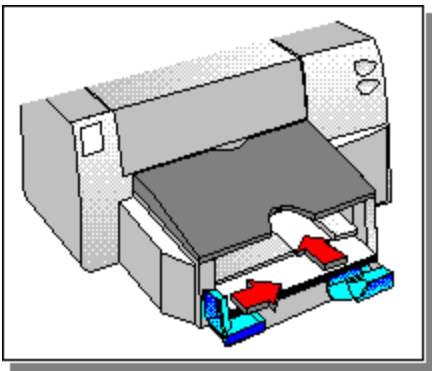

Build tag spacer 16

Print on Both Sides of the Page

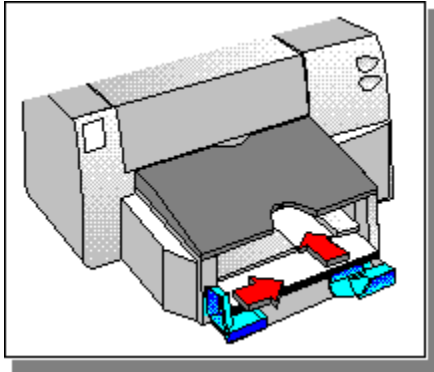

Step 1 of 4

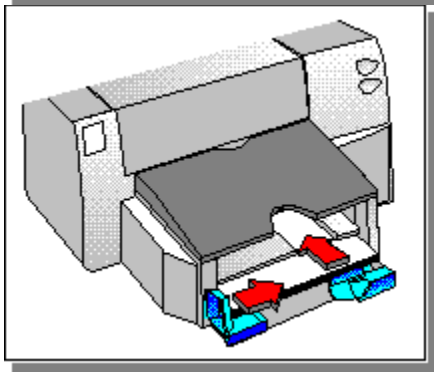
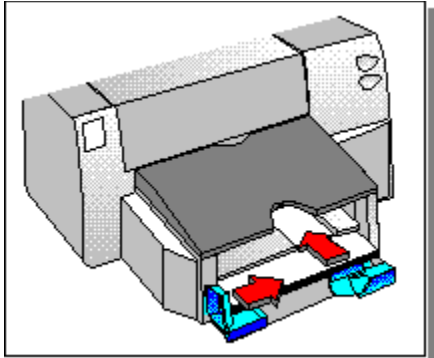

- 1 In HP's print settings dialog box, click on the Paper tab. In the Two-sided Printing box, select either Book or Tablet, and then click OK.

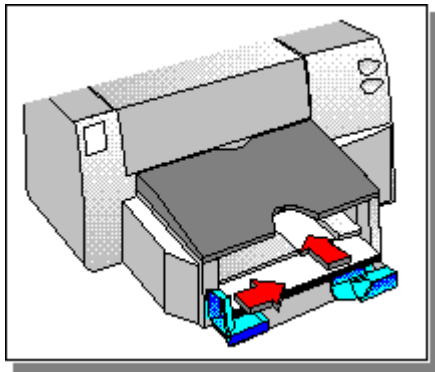

Click here

for instructions on changing print settings.

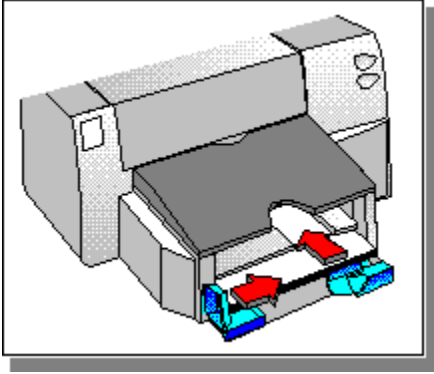

Print on Both Sides of the Page

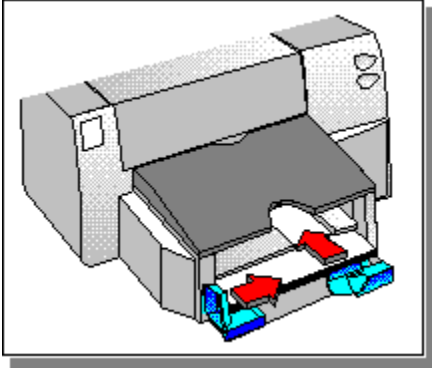

Step 2 of 4

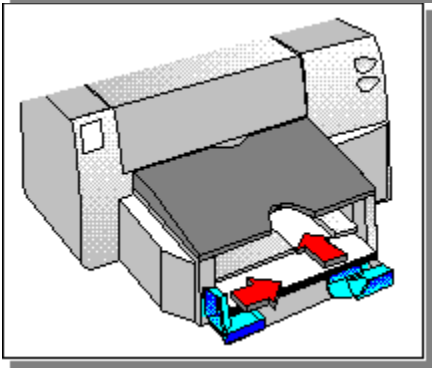
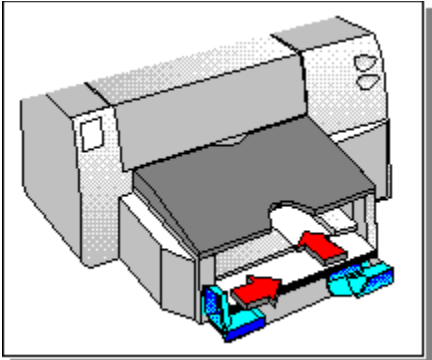

2 Print your document.

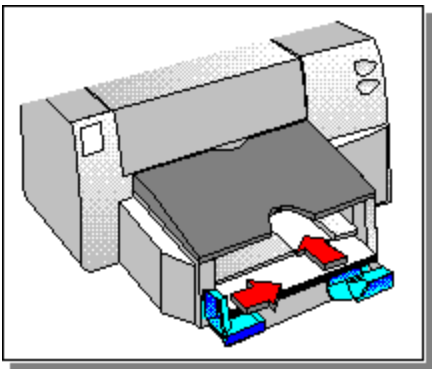

Print on Both Sides of the Page

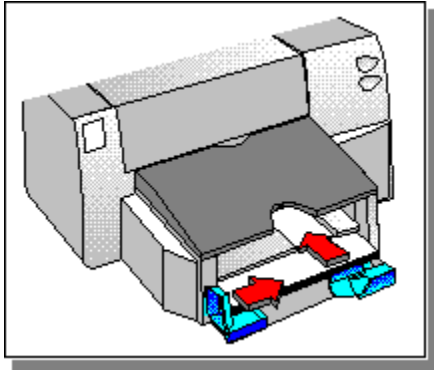

Step 3 of 4

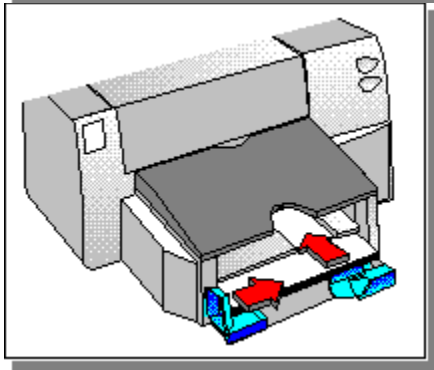
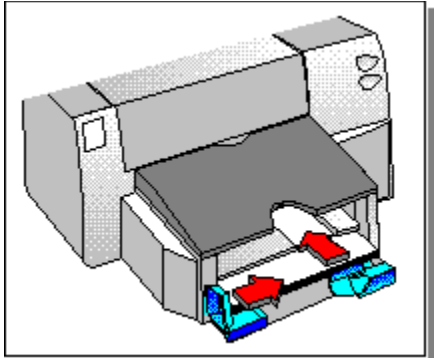

- 3 After all of the odd-numbered pages print, a screen appears with instructions on printing the even-numbered pages. Follow the instructions on the screen.

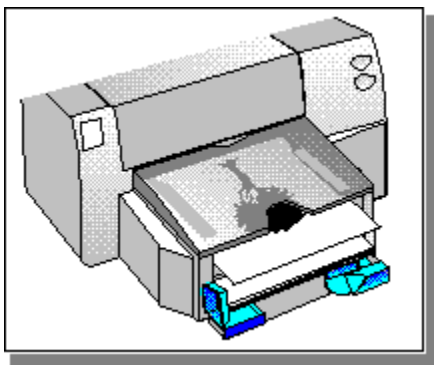

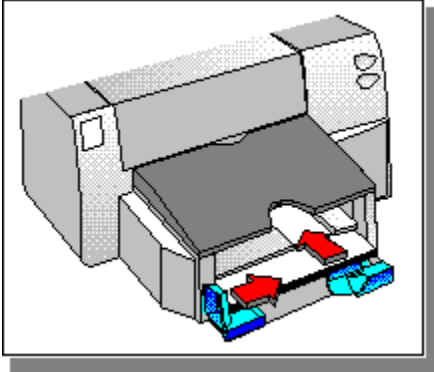

Print on Both Sides of the Page

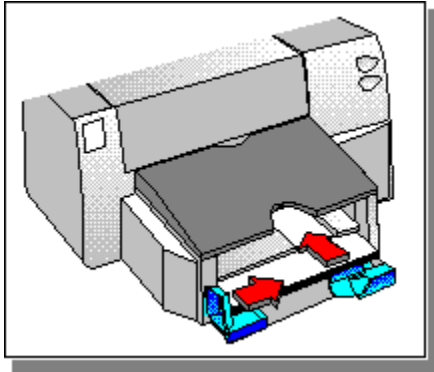

Step 4 of 4

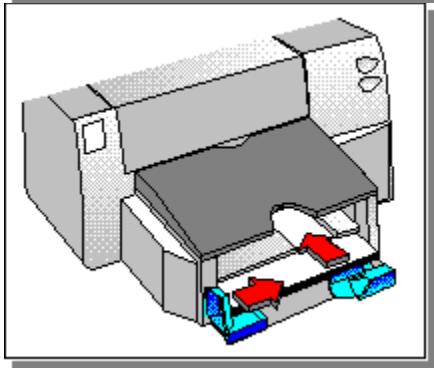
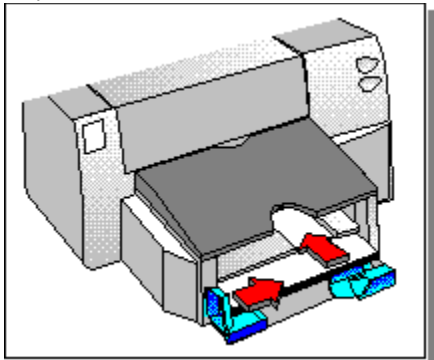

- 4 When you have removed and reinserted the odd-numbered pages according to the instructions on the screen, click Continue to finish printing your document.

The even-numbered pages will print on the reverse side of the odd-numbered pages.

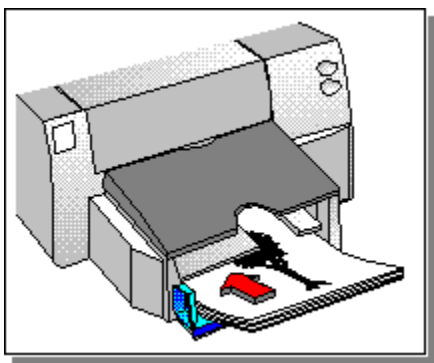

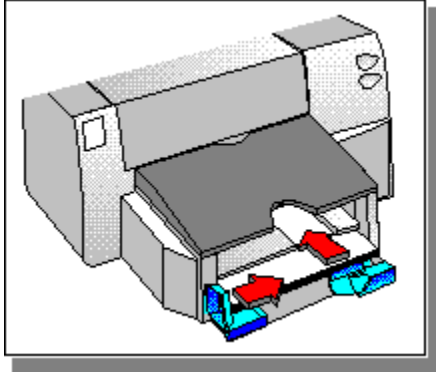

Build tag spacer 17

Change Print Settings

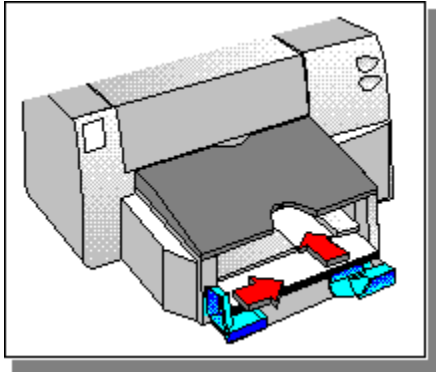

To change print settings for only the current document, change the print settings from within your software program.

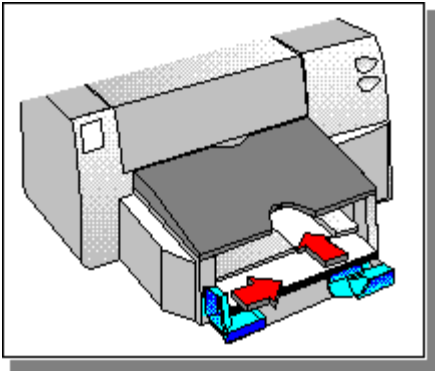

Click here

[for instructions on changing print settings from your software program.](#)

To set default print settings for all documents, change settings in the Printers folder.

Note Settings made from within a software program can override settings that have been made in the Printers folder.

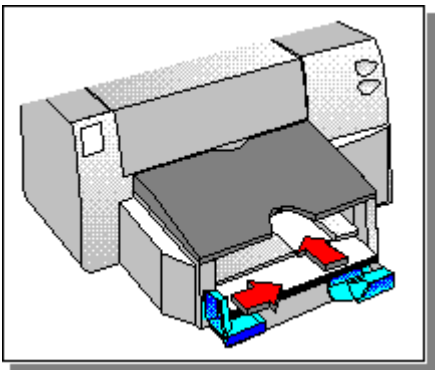

Click here

[for instructions on changing print settings from the Printers folder.](#)

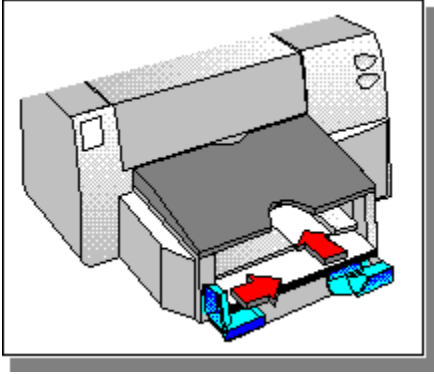

Build tag spacer 18

Build tag spacer 19

Build tag spacer 20

Change Print Settings from Your Software Program

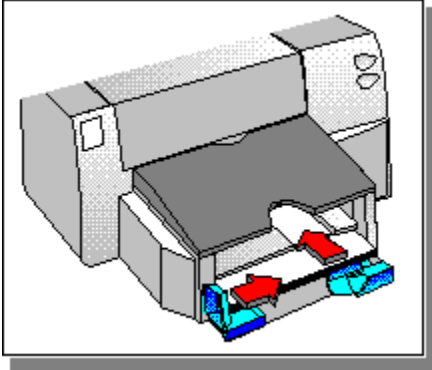

Step 1 of 1

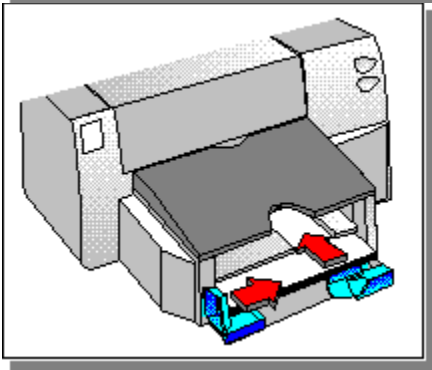
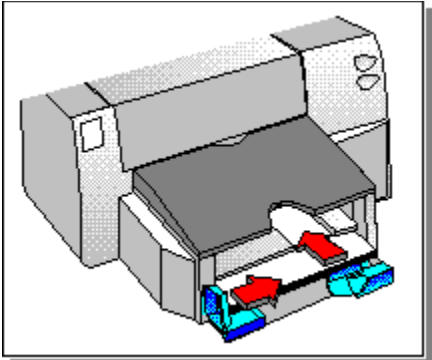

This procedure will vary depending on the software program you are using.

1 From the File menu, select Page Setup or Print Setup, and then click Options.

-Or-

From the File menu, select Print, and then click Properties.

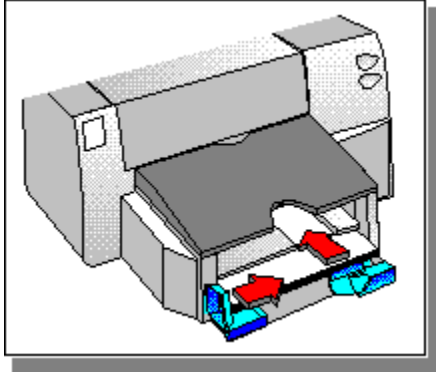

Build tag spacer 21

Build tag spacer 22

Change Print Settings from the Printers Folder

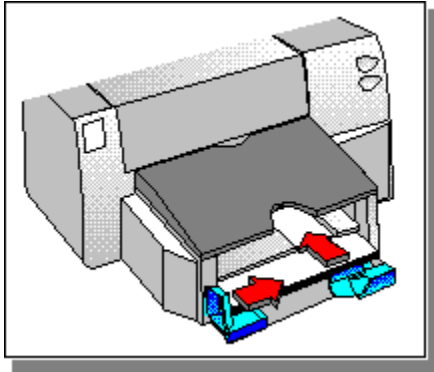

Step 1 of 3

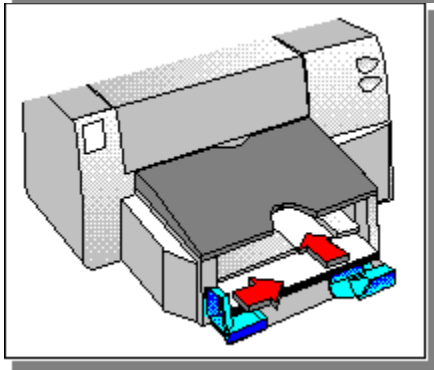
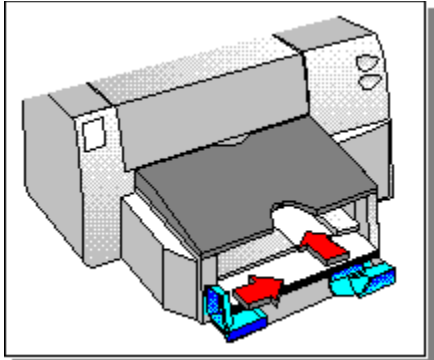

1 On the taskbar, click Start, and then select Printers from the Settings menu.

-Or-

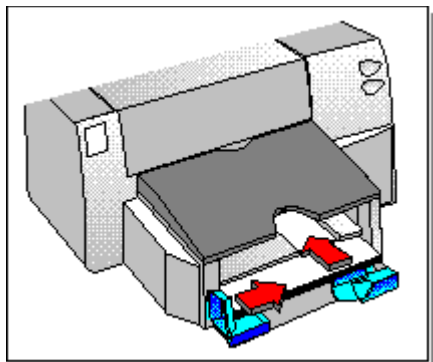

Click here

to open the Printers folder now.

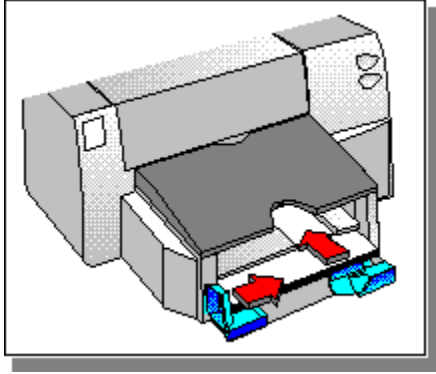

Change Print Settings from the Printers Folder

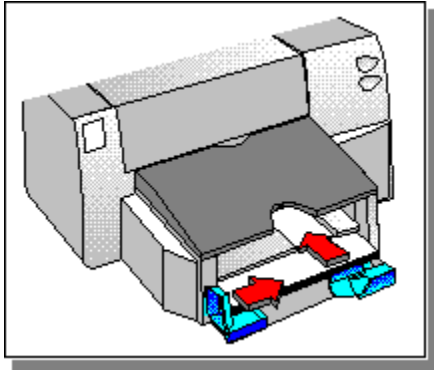

Step 2 of 3

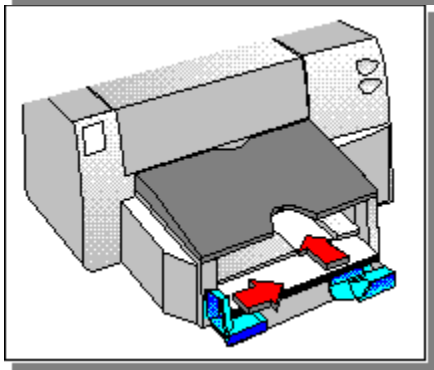
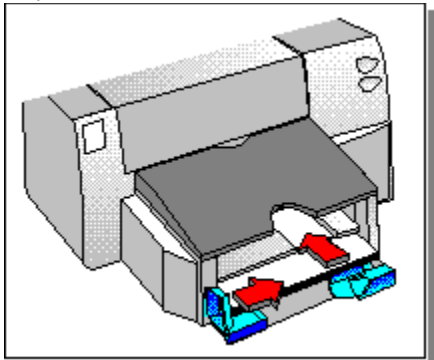

- 2 Click the icon for your HP DeskJet printer, then select Properties from the File menu.
You can now change print settings.

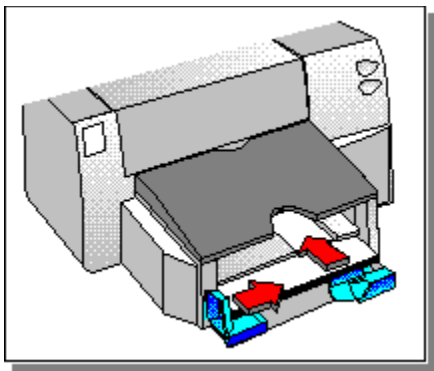

Change Print Settings from the Printers Folder

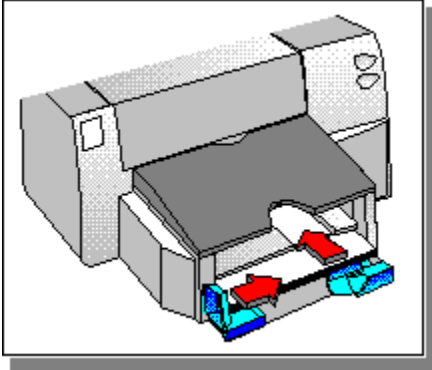

Step 3 of 3

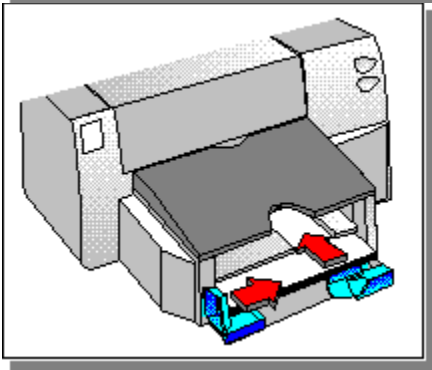
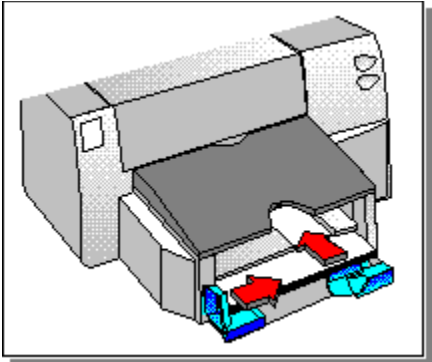

3 Click the Close box to close the window.

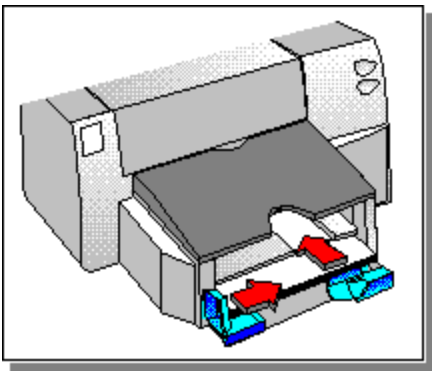

Build tag spacer 23

Build tag spacer 24

Enable Bi-directional Support

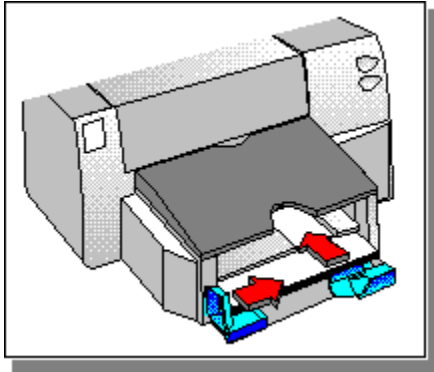

Step 1 of 4

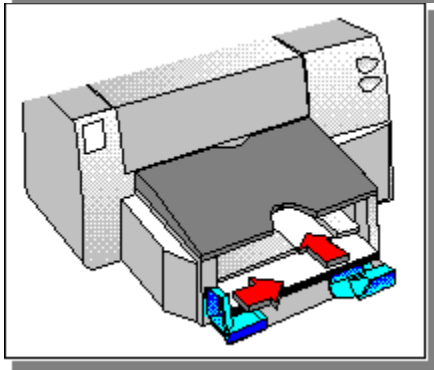
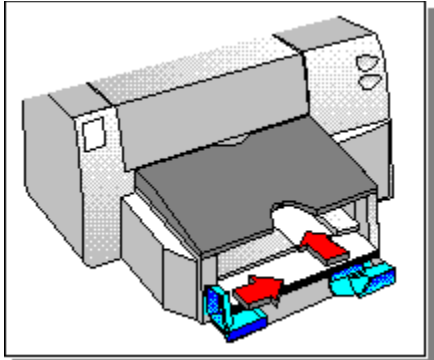

- 1 Open the Printers folder, click the icon for your HP DeskJet printer, and then select Properties from the File menu.

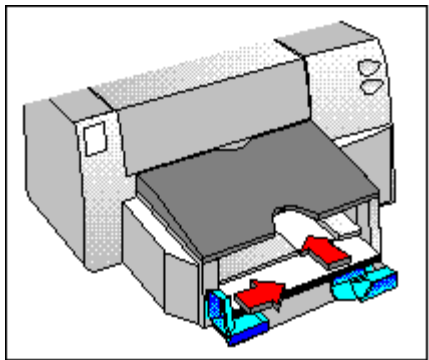

Click here

to open the Printers folder now.

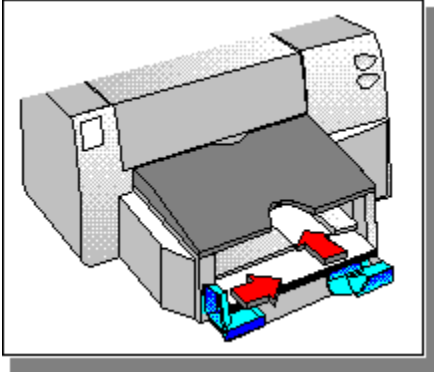

Enable Bi-directional Support

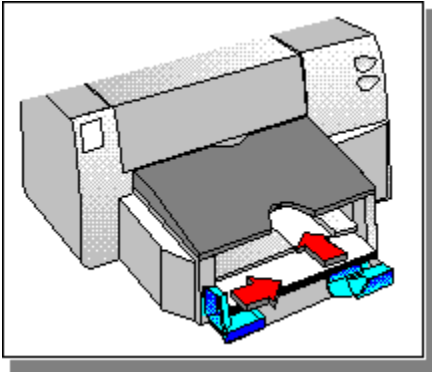

Step 2 of 4

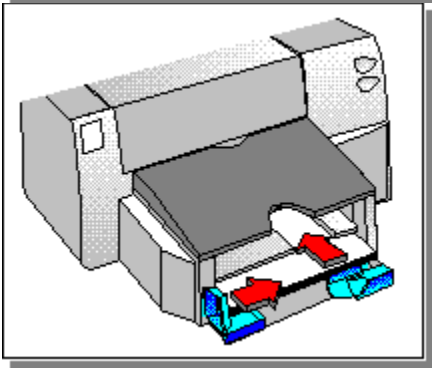
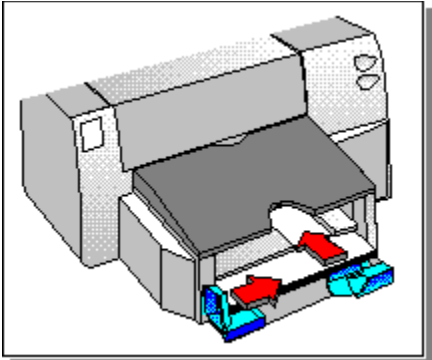

2 Click the Details tab.

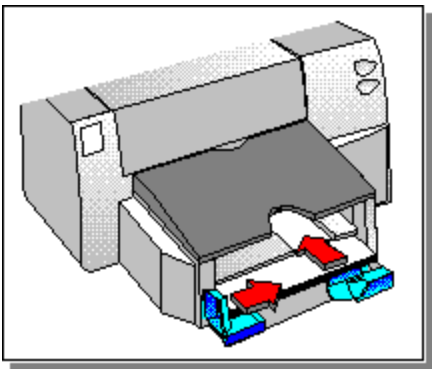

Enable Bi-directional Support

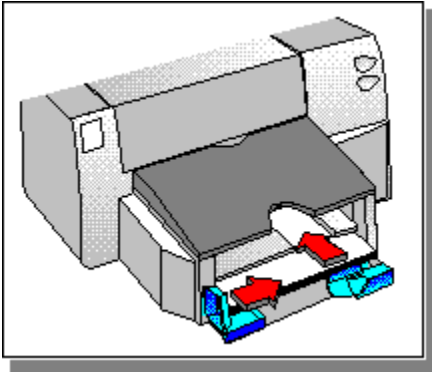

Step 3 of 4

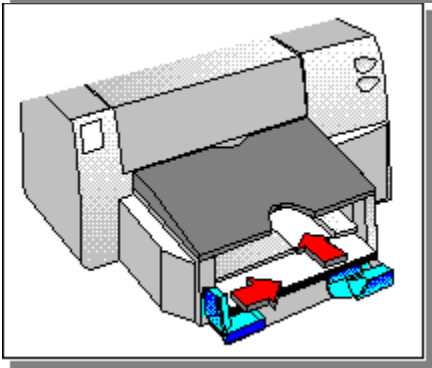
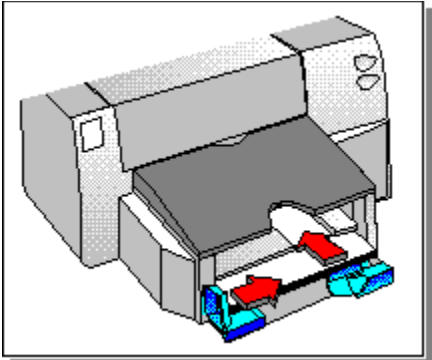

3 Click the Spool Settings button.

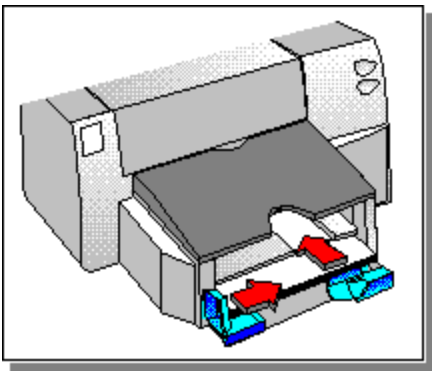

Enable Bi-directional Support

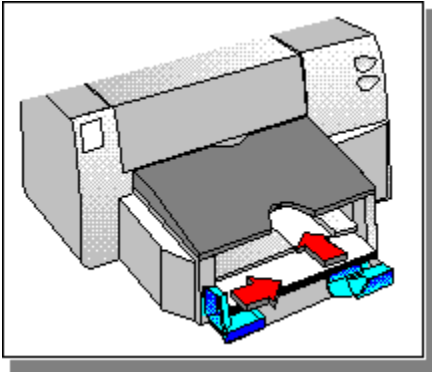

Step 4 of 4

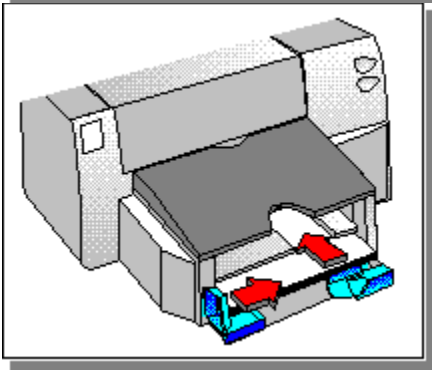
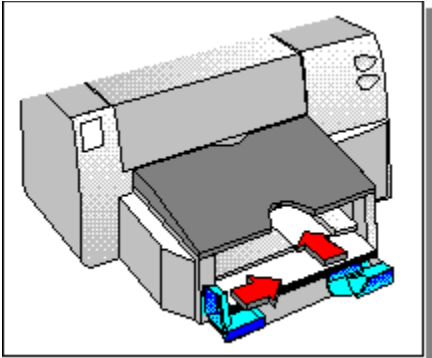

4 Check the Enable Bi-directional Support For This Printer checkbox.

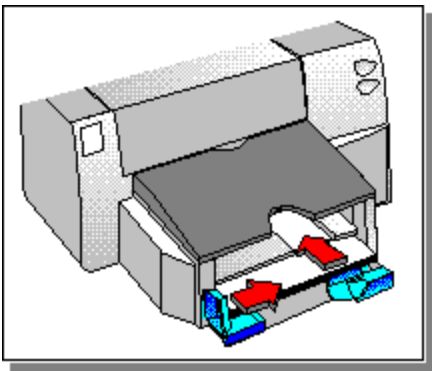

Build tag spacer 25

Print Directly to the Printer

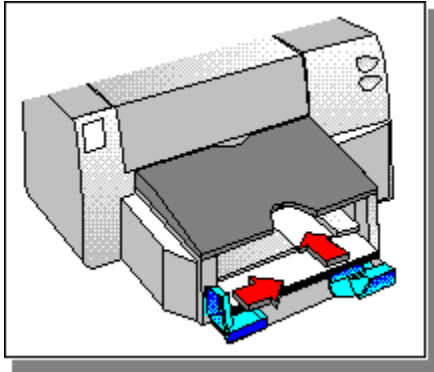

Step 1 of 4

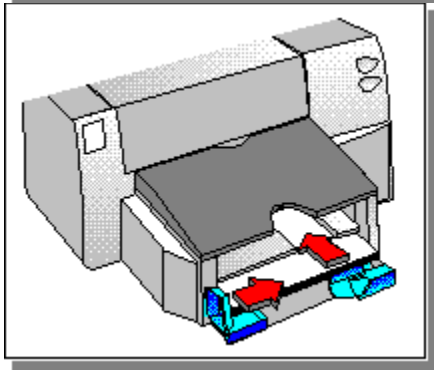
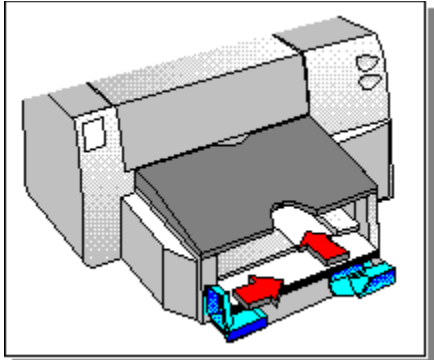

- 1 Open the Printers folder, click the icon for your HP DeskJet printer, and then select Properties from the File menu.

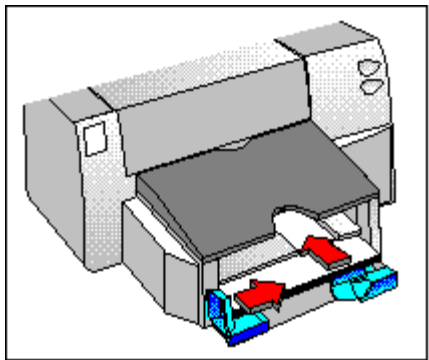

Click here

to open the Printers folder now.

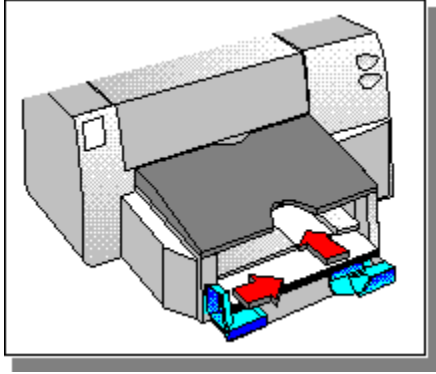

Print Directly to the Printer

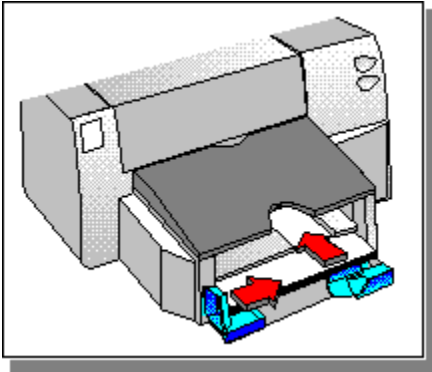

Step 2 of 4

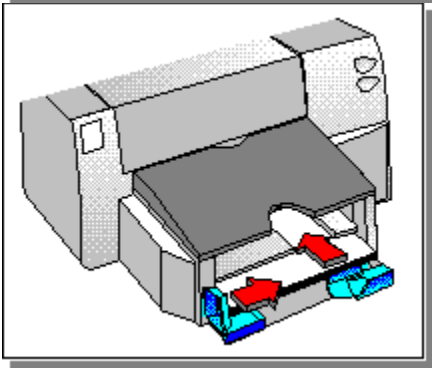
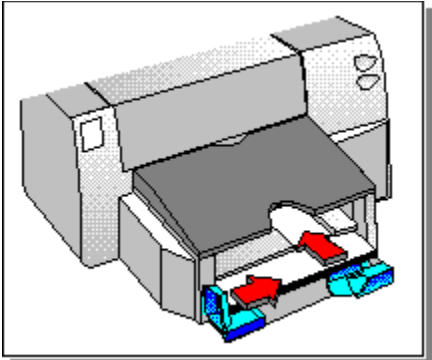

2 Click the Details tab.

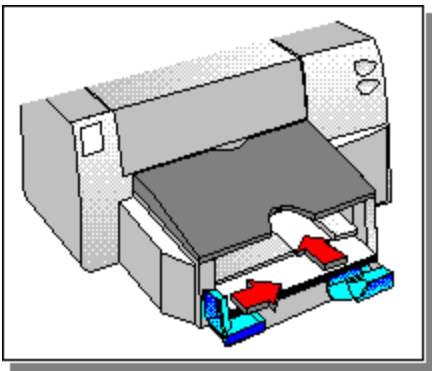

Print Directly to the Printer

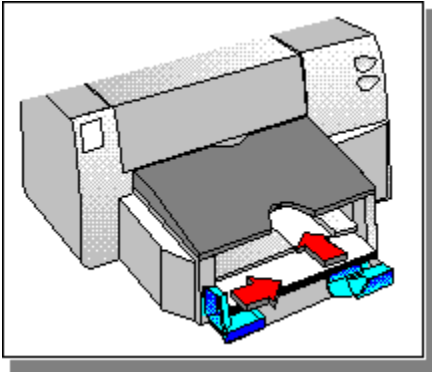

Step 3 of 4

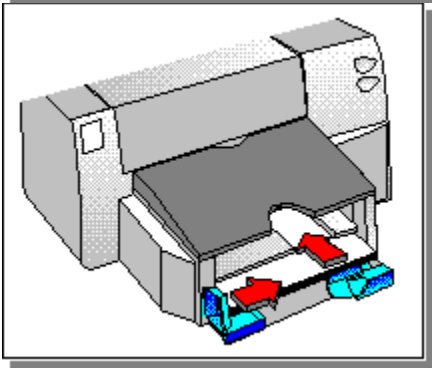
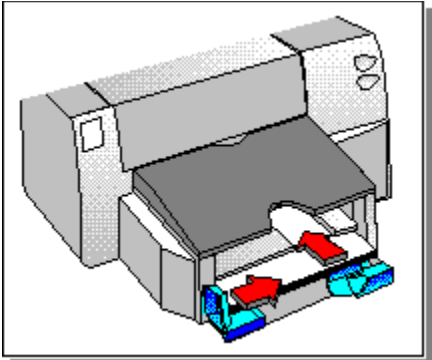

3 Click the Spool Settings button.

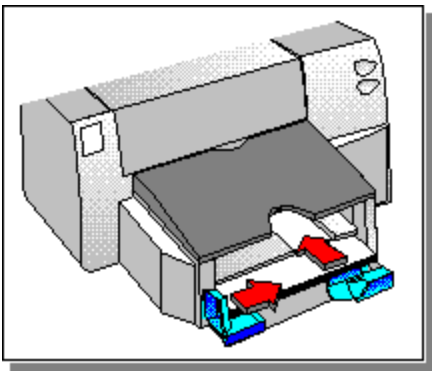

Print Directly to the Printer

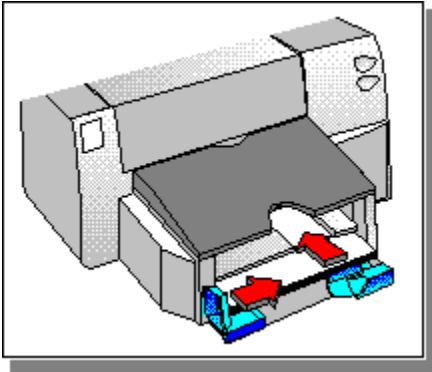

Step 4 of 4

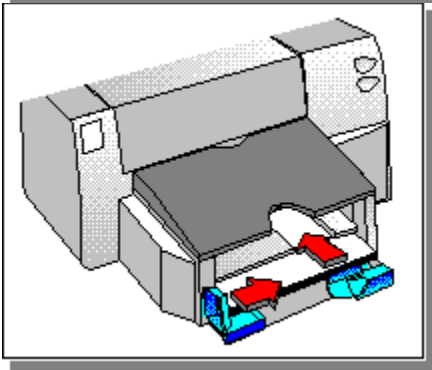
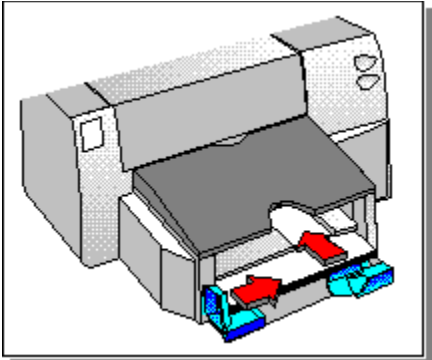

4 Check the Print Directly To The Printer checkbox.

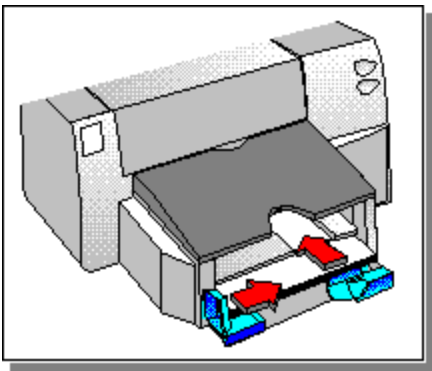

Build tag spacer 26

Build tag spacer 27

Print on a Variety of Paper Types, Sizes, and Envelopes

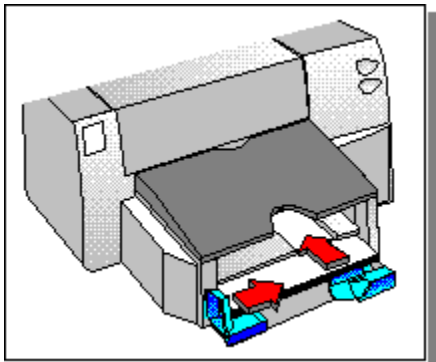
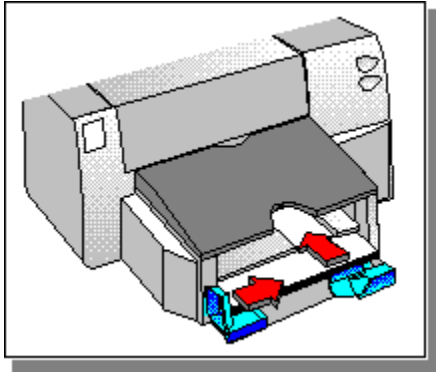

Print transparencies or slides.

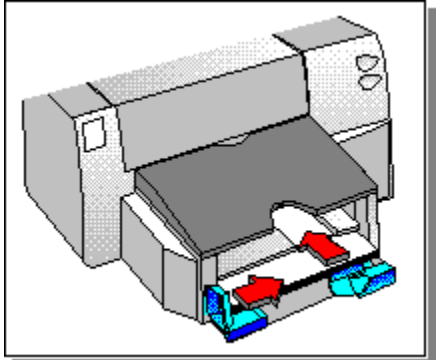

Print on HP premium papers.

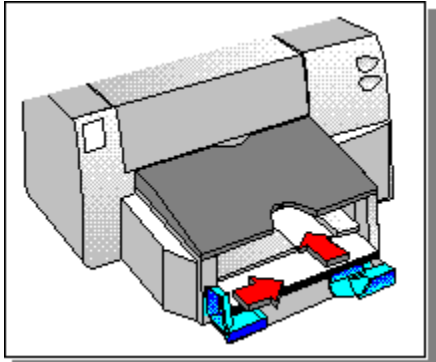

Print on labels.

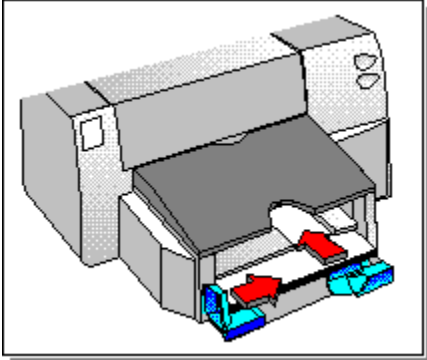

Print on standard-sized paper.

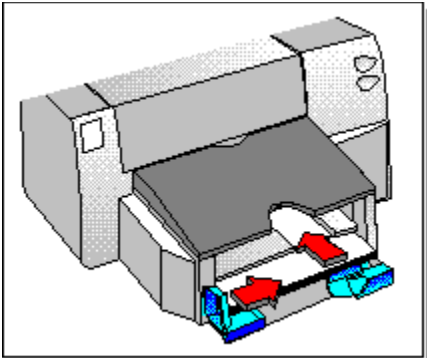

Print on custom-sized paper.

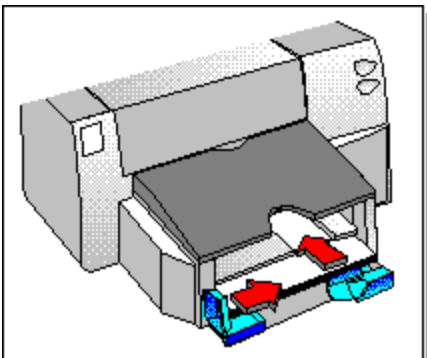

Print on envelopes.

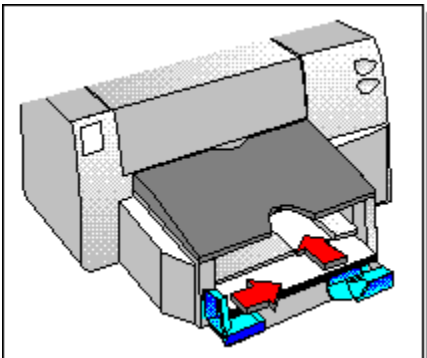

Print on cards.

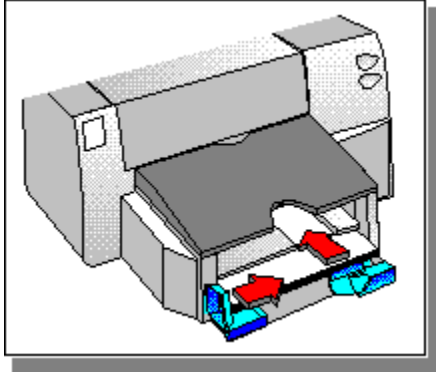

Build tag spacer 28

Build tag spacer 29

Build tag spacer 30

Build tag spacer 31

Book

Prints using both sides of the page, with the binding along one side of the book. Selecting portrait or landscape page orientation determines the book's edge.

Two-sided printing requires that you manually reinsert the stack of paper into the IN tray. Follow the on-screen instructions for reinserting paper.

Collate

To print a multiple page document in order, from last page to first. When printing multiple copies, each copy is printed completely, in order, before printing the next copy.

ColorSmart technology

The HP ColorSmart technology within the [HP print settings dialog box](#) analyzes your documents and automatically adjusts the color settings to produce the best possible color output. Although ColorSmart will provide you with the best print quality, you can manually override the settings at any time by selecting the Manual option on the Setup tab of the HP print settings dialog box.

Continuous (banner) paper

Paper provided in continuous form, also called computer paper and Z-fold paper. It is usually perforated so that it can be separated into individual sheets.

Cut-sheet paper

Standard office, copy, or printer paper pre-cut into individual sheets.

Default printer

The printer that is used if you choose the Print command without first specifying which printer you want to use with an application. It should be the printer you use most often.

Even-numbered pages

Pages with even numbers, usually the left-hand pages in a book.

Grayscale

A grayscale consists of shades of gray, from white to black. When a color document is printed on a black-and-white printer, colors are converted to and represented by their grayscale equivalents.

HP DeskJet Toolbox

The HP DeskJet Toolbox provides access to the information you need to use your printer, including procedures for basic printer tasks, step-by-step problem solving for common printing problems, printer status information, and printer functions, such as printing samples pages and aligning print cartridges.

HP print settings dialog box

The HP print settings dialog box allows you to access printer features from a software program, such as a word-processing or graphics program. You use the HP print settings dialog box to select print quality, page orientation, paper type, paper size, and ColorSmart options.

Media

The paper or other material on which you are printing. Paper, transparencies, labels, and envelopes are examples of media.

Odd-numbered pages

Pages with odd numbers, usually the right-hand pages in a book.

Orientation or page orientation

The direction in which information is printed on a page. Choose Portrait orientation to print across the width of the page, letter style. Choose Landscape orientation to print across the length of the page, spreadsheet style.

Printer services

Printer Services provide print status information and access to printer functions, such as printing sample pages, diagnostic testing, or aligning print cartridges.

Tablet

Prints using both sides of the page, with the binding along the top of the pages. This option reverses the back side of the page so that the pages can be read calendar-style.

Two-sided printing requires that you manually reinsert the stack into the IN tray. Follow the on-screen instructions for reinserting paper.

