

GDC 048R218-000
Issue 3, August 1996

Installation and Operation

DeskTop 56/64 D



Warning

This equipment generates, uses, and can radiate radio frequency energy and if not installed and used in accordance with the instruction manual, may cause interference to radio communications. It has been tested and found to comply with the limits for a Class A computing device pursuant to CISPR 22 which is designed to provide reasonable protection against such interference when operated in a commercial environment. Operation of this equipment in a residential area is likely to cause interference, in which case the user at his own expense will be required to take whatever measures may be required to correct the interference. The user is cautioned that any changes or modifications not expressly approved by General DataComm void the user's authority to operate the equipment.

This digital apparatus does not exceed Class A limits for radio noise emissions from digital apparatus described in the Radio Interference Regulations of the Canadian Department of Communications.

Le présent appareil numérique n'émet pas de bruits radioélectriques dépassant les limites applicables aux appareils numériques de la classe A prescrites dans le Règlement sur le brouillage radioélectrique édicté par le ministère des Communications du Canada.

Warranty

General DataComm warrants that its equipment is free from defects in materials and workmanship. The warranty period is one year from the date of shipment. GDC's sole obligation under its warranty is limited to the repair or replacement of the defective equipment provided it is returned to GDC, transportation prepaid, within a reasonable period. This warranty will not extend to equipment subjected to accident, misuse, or alterations or repair not made by GDC or authorized by GDC in writing. *The foregoing warranty is exclusive and in lieu of all other warranties, express or implied, including but not limited to, warranties of merchantability and fitness for purpose.*

Trademarks

GDC, GDC APEX, General DataComm, and the General DataComm logo are trademarks of General DataComm, Inc. in the United States and other countries. Sun Microsystems and Solaris are trademarks of Sun Microsystems, Inc. SPARCstation is a trademark of SPARC International, Inc. and is licensed exclusively to Sun Microsystems, Inc. UNIX is a registered trademark of Novell, Inc. Ethernet is a trademark of Xerox Corporation. X Window System is a trademark of the Massachusetts Institute of Technology. IXI is a trademark of IXI Limited. Motif and OSF/Motif are registered trademarks of the Open Software Foundation, Inc. (OSF).

All other products or services mentioned in this document are identified by the trademarks, service marks, or product names as designated by the companies who market those products. Inquiries concerning such trademarks should be made directly to those companies.

Copyright

© 1995 General DataComm, Inc. All rights reserved.
P.O. Box 1299, Middlebury, Connecticut 06762-1299 U.S.A.

This publication and the software it describes contain proprietary and confidential information. No part of this document may be copied, photocopied, reproduced, translated or reduced to any electronic or machine-readable format without prior written permission of General DataComm, Inc.

The information in this document is subject to change without notice. General DataComm assumes no responsibility for any damages arising from the use of this document, including but not limited to, lost revenue, lost data, claims by third parties, or other damages. If you have comments or suggestions concerning this manual, please write to Technical Publication Services or call 1-203-758-1811.

Table of Contents

Preface

1 System Description

System Description	1-1
Features	1-1
Diagnostics	1-2

2 Installation

Installation Requirements	2-1
Unpacking and Handling	2-1
Pre-operational Check	2-1
Option Selection	2-3
Electrical Connections	2-3

3 Operation

Controls and Indicators	3-1
-------------------------------	-----

4 Tests

Point-to-Point Testing	4-2
Line Loopback Test	4-3
Remote Loopback Test	4-4
Self-Test	4-5
End-to-End Self-Test	4-7
CSU Loopback Test	4-8
DSU Loopback Test	4-9

A Technical Characteristics

Index

Preface

Scope

This manual describes how to install and operate a General DataComm DeskTop 56/64 DSU. It is written for operators and installers and assumes a working knowledge of data communications.

Organization

This manual has four chapters and one appendix:

- *Chapter 1 - System Description* gives a general description of the DeskTop 56/64 unit.
- *Chapter 2 - Installation* shows you how to set up the unit.
- *Chapter 3 - Operation* contain illustrations that describe controls and indicators for easy operation.
- *Chapter 4 - Tests* contain pre-operational and performance checks on the equipment.
- *Appendix A - Technical Characteristics* list the unit specifications.

Document Conventions

Level 1 paragraph headers introduce major topics.

Level 2 paragraph headers introduce subchapters of major topics.

Level 3 paragraph headers introduce subchapters of secondary topics.



Notes present special instructions, helpful hints or general rules.

Related Publications

The following documents have additional information that may be helpful when using this product:

- Operating and Installation Instructions for DeskTop 500
GDC 048R209-000
- Operating and Installation Instructions for DeskTop 500A
GDC 048R210-000

GDC publication numbers (e.g., GDC 048R218-000) are used to track and order technical manuals. Publication numbers use the following format:

GDC NNNRnnn-000 or GDC NNNRnnn-Vnnn

NNN	identifies the product family (e.g. DSU)
R	denotes a technical publication
nnn	a number assigned by Technical Publications
000	identifies a hardware product and does not change
Vnnn	the software version associated with a product may be updated periodically

The Issue Number on the title page only changes when a hardware manual is revised or when a manual is reprinted for some other reason.

Service and Support

General DataComm is committed to providing the service and support needed to install, manage, and maintain your equipment. For information about service programs or for assistance with your support requirements, contact your local Sales Representative or call General DataComm Service Corporation at the 24-hour toll free number listed below:

- in the U.S. dial 1-800-243-1030
- outside the U.S. dial 1-203-598-7526

Be ready with the site name and phone number and a description of the problem and the next available support representative will promptly return your call.

GDC 048R218-000

Hands-on training courses are provided by General DataComm Educational Services. Courses range from basic data communications, modems and multiplexers, to complex network and ATM systems and are taught in Connecticut or at a customer location. Call 1-800-242-1030 and follow the menu instructions to discuss educational services or to receive a course schedule.

Safety Instructions

Antistatic Precautions

Electrostatic discharge (ESD) results from the buildup of static electricity and can cause computer components to fail. Electrostatic discharge occurs when a person whose body contains a static buildup touches a computer component.

The equipment may contain static-sensitive devices that are easily damaged and proper handling and grounding is essential. Use ESD precautionary measures when installing parts or cards and keep the parts and cards in antistatic packaging when not in use. If possible, use antistatic floorpads and workbench pads.

When handling components, or when setting switch options, always use an antistatic wrist strap connected to a grounded equipment frame or chassis. If a wrist strap is not available, periodically touch an unpainted metal surface on the equipment. Never use a conductive tool, such as a screwdriver or a paper clip, to set switches.

Safety Guidelines

The following symbols are used when unsafe conditions exist or when potentially hazardous voltages are present:



Caution statements identify conditions or practices that can result in damage to the equipment or in loss of data.



Warning statements identify conditions or practices that can result in personal injury or loss of life.

Always use caution and common sense. To reduce the risk of electrical shock, do not operate any equipment with the cover removed. Repairs must be performed by qualified service personnel only.

- Never install telephone jacks in a wet location unless the jack is designed for that location.
- Never touch uninsulated telephone wires or terminals unless the telephone line is disconnected at the network interface.
- Use caution when installing telephone lines and never install telephone wiring during an electrical storm.

Regulatory Notices

FCC Part 68 Compliance

Connection of data communications equipment to the public telephone network is regulated by FCC Rules and Regulations. This equipment complies with Part 68 of these regulations which require all of the following:

All connections to the telephone network must be made using standard plugs and telephone company provided jacks or equivalent. Connection of this equipment to party lines and coin telephones is prohibited. A label on the back of the front panel of data communications equipment and on the underside or rear panel of other equipment provides the FCC Registration number and the Ringer Equivalence Number (REN) for the unit. If requested, give this information to the telephone company.

If the unit causes harm to the telephone network, the telephone company may discontinue your service temporarily and if possible, you will be notified in advance. If advance notice is not practical, you will be notified as soon as possible and will be advised of your right to file a complaint with the FCC. The telephone company may change its communication facilities, equipment, operations and procedures where reasonably required for operation. If so, the telephone company will notify you in writing. You must notify the telephone company before disconnecting equipment from 1.544 Mbps digital service. All repairs or modifications to the equipment must be performed by General DataComm. Any other repair or modification by a user voids the FCC registration and the warranty.

GDC 048R218-000

Canada DOC Notification

The Canadian Department of Communications label identifies certified equipment. This certification means that the equipment meets certain telecommunications network protective, operational, and safety requirements. The Department does not guarantee the equipment will operate to the user's satisfaction.

Before installing this equipment, users should ensure that it is permissible to be connected to the facilities of the local telecommunications company. The equipment must also be installed using an acceptable method of connection. In some cases, the company's inside wiring associated with a single line individual service may be extended by means of a certified connector assembly (telephone extension cord). The customer should be aware that compliance with the above conditions may not prevent degradation of service in some situations.

Repairs to certified equipment should be made by an authorized Canadian maintenance facility designated by the supplier. Any repairs or alterations made by the user to this equipment, or equipment malfunctions, may give the telecommunications company cause to request the user to disconnect the equipment.

Users should ensure for their own protection that the electrical ground connections of the power utility, telephone lines, and internal metallic water pipe system, if present, are connected together. This precaution may be particularly important in rural areas. *Users should not attempt to make such connections themselves, but should contact the appropriate electric inspection authority, or electrician, as appropriate.*

Deutschland

Installations Anweisungen: Installieren Sie die Telefonleitungen nicht während eines Gewitters. Installieren Sie die Telefonleitungen nicht in einem feuchten Raum, außer die Dose entspricht den Vorschriften für Feuchträume. Berühren Sie unisolierte Telefonleitungen oder Einrichtungen nicht, außer diese sind vom Telefonnetz getrennt. Vorsicht bei der Installierung oder Änderung von Telefonleitungen. *Achtung:* Es gibt keine durch den Benutzer zu wartende Teile im Gerät. Wartung darf nur durch qualifiziertes Personal erfolgen.

Glossary of Terms

Bit

A binary digit, the representation of a signal, wave or state, as either a binary zero or a one.

Bps

Bits per second; basic unit of measure for serial data transmission capacity; also Kbps (kilobits), for thousands of bits per second; Mbps (megabits), for millions of bits per second; Gbps (gigabits), for billions of bits per second; Tbps (terabits), for trillions of bits per second.

ITU-T

International Telecommunications Union - Telecommunications Standardization Sector. A committee that sets international communications standards.

Channel

Part of a circuit path through several entities in a communication system. A channel runs between two nodes.

Data

Digitally represented information, which includes voice, text, facsimile and video.

Dataphone

A service and trademark of AT&T; generically refers to the transmission of data over the phone network (Dataphone Digital Service, or DDS) or to equipment furnished by the telephone company for data transmission.

Data Service Unit

Component of customer premises equipment (CPE) used to interface to a digital circuit, such as DDS and T1; now generally combined with a CSU; performs conversion of customer's data stream to bipolar format for transmission.

DDS

Dataphone digital service; private-line digital service offered intra-LATA by BOCs, inter-LATA by AT&T Communications, with data rates typically at 2.4, 4.8, 9.6 and 56 K bps; now a part of the services listed by AT&T under the Accunet family of offerings.

GDC 048R218-000

Diagnostics

Tests used to detect malfunctions in a system or component.

Digital

Techniques and equipment in which information is encoded as either a binary "1" or "0"; the representation of information in discrete binary form, discontinuous in time, as opposed to the analog representation of information in variable, but continuous waveforms.

DSU

Data Service Unit.

DTE

Data Terminal Equipment.

LED

Light-emitting diode.

Link

The combination of communications devices, media and software intelligence that is required to effect data communications.

Loopback

Diagnostic procedure used for transmission devices; a test message is sent to a device being tested, which is then sent back to the originator and compared with the original transmission; loopback testing may be within a locally attached device or conducted remotely over a communications circuit.

Multipoint Line

A single communications channel (typically a leased telephone circuit) to which more than one station or logical unit are attached, though only one may transmit at a time; such arrangements usually require some kind of polling mechanism, under the control of a master station, to ensure that only one device transmits data at a time; also, a multi-drop line.

Network

An interconnected group of nodes; a series of points, nodes or stations connected by communications channels; the assembly of equipment through which connections are made between data stations.

Point-to-Point

A circuit that connects two points directly with generally no intermediate processing nodes or computers, although there could be switching facilities; a type of connection, such as a phone-line circuit, that links two, and only two, logical entities.

Synchronous Transmission

Data communications in which characters or bits are sent at a fixed rate, with the transmitting and receiving devices synchronized, eliminating the need for start and stop bits necessary in asynchronous transmission and significantly increasing data throughput rates.

Terminal

A point in a network at which data can either enter or leave; a device, usually equipped with a keyboard, often with a display, capable of sending and receiving data over a communications link (IBM); generically the same as data terminal equipment (DTE).

Test Generator

Allows the operator to select a 511-bit test pattern generator.

Transmission

The dispatching of a signal, message or other form of intelligence by wire, radio, telegraphy, telephony, facsimile or other means (ISO); a series of characters, messages or blocks, including control information and user data; the signaling of data over communications channels.

1 System Description

System Description

The DeskTop 56/64 is a Data Service Unit (DSU) that includes an on-board Channel Service Unit (CSU) for direct connection to DATAPHONE Digital Service (DDS).

The DeskTop 56/64 provides transmission and reception of serial binary data over the 4-wire metallic circuits used in the DDS. It operates synchronously at data rates of 56 and 64K bps.

The DeskTop 56/64 normally derives timing from the DDS network clocking system (network or slave mode) or you can option it for internal (DSU) or external (DTE) clocking. The business equipment interface conforms to ITU-T V.35.

Table 1-1 lists the part numbers for the DeskTop 56/64's standard and optional equipment. Appendix A describes the DeskTop 56/64's technical characteristics.

Features

- DSU/CSU for direct connection to the DATAPHONE* Digital Service.
- Operates at 56K bps Standard DDS or at 64K bps for "clear channel" service.
- Provides extended range performance at both rates.
- ITU-T V.35 DTE Interface.
- Operates in both point-to-point and multipoint configurations.
- Provides a powerful Remote Loopback (RL) test for enhanced diagnostic capabilities. Along with this standard General DataComm RL, it also provides V.54 and PN 127 type RLs.

Diagnosics

The DeskTop 56/64 incorporates built-in diagnostic circuits that allow you to perform quick and thorough performance tests for checking DSU operation. You can perform the Line Loopback (LL) and Remote Loopback (RL) tests individually or in conjunction with the DSU Self-Test (ST) feature, using front panel push buttons. The Self-Test feature uses 511- or 2047-bit pattern generator and receiver circuits.

The DeskTop 65/64 also supports Serving Test Center (STC) diagnostics: CSU Loopback (current reversal), DSU Loopback (alternating pattern), and DSU Latching Loopback at 64 Kbps.

Table 1-1 Equipment List

Description	GDC Part No.
DeskTop 56/64 DSU, with ITU-T V.35 Interface, 117 V ac (Domestic)	048A 10 1-001
Optional Equipment	
Wall-mounted AC Transformer, 117 ac	700-053-002
Crossover Adapter for DDS/Private Line Use	208-038-001
Plug-to-Plug Cable Assembly, 7 Feet	830-028-807
V.35 Male-to-Male, Straight Through Cable	027H516-XXX*
*XXX = Cable length in feet	

GDC 048R218-000

2 Installation

Overview

This chapter guides you through the process of installing and using the DeskTop 56/64 DSU.

Installation Requirements

Locate the unit in a ventilated area where the ambient temperature does not exceed 122°F (50°C).

Unpacking and Handling

Inspect the unit for damage; if any is observed, notify the shipper immediately. Save the box and packing material; you can use it to reship the unit, if necessary. Do not place the unit directly above equipment that generates a large amount of heat (such as power supplies).

Pre-operational Check

Upon power-up, the DSU lights all of its LEDs, and then performs an Analog Loopback Self-Test. The DSU indicates a failure by continuously flashing all its LEDs. If the DSU fails the power-up self-test (refer to *chapter 4*) contact General DataComm Service Corporation .

Before connecting the DSU to the communications line or DTE, you can give it a further pre-operational check by performing a Line Loopback Self-Test (refer to *Chapter 4*) to verify operation.

If the DSU passes the test, but subsequently fails to perform data communications, it is probably not at fault. There is either an error in option selection or installation, or a faulty communications line or remote installation.

Checking Option Selection

All option selections are made using external switches S510 and S511. Verify that option selection is the same as illustrated in *Figure 2-1*. All option switches are left in the OFF (default) position.

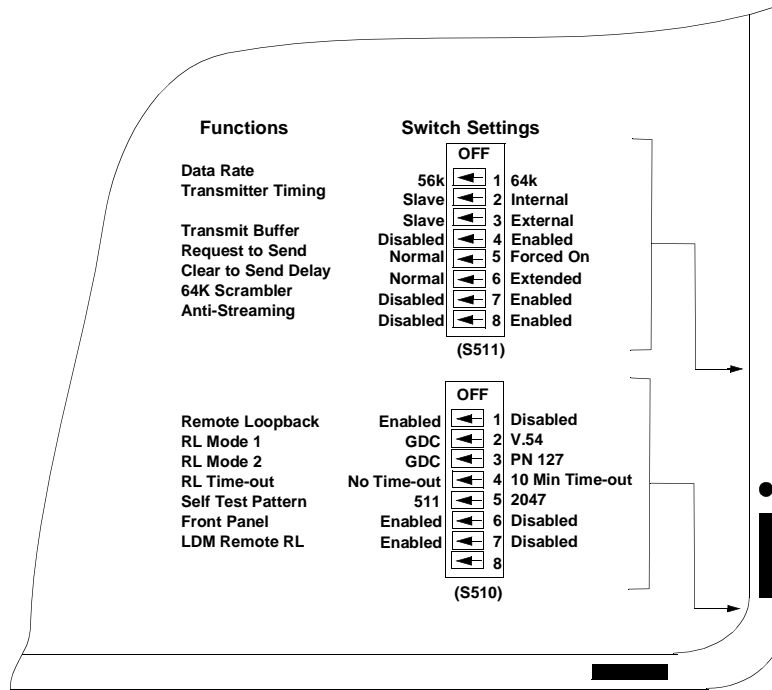

Figure 2-1 Option Location and Selection

Checking the Installation and Line

Recheck the cable and line connections and, if necessary, perform the tests in *Chapter 4* to isolate the problem.

Verify that the remote DSU is a compatible type (e.g., a DSU operating at the same data rate).

Verify that the DDS network is operating at the correct rate. If the DSU does not check out properly, replace it with a spare and repeat the test. Do not attempt to repair the DSU.

For assistance, you may contact General DataComm Services at the number listed in the *Preface* of this manual.

GDC 048R218-000

Option Selection

The field-selectable options adapt the DeskTop 56/64 to a variety of configurations. You select these options by positioning DIP switches on the bottom of the DSU. The DSU resets following any option change.

Figure 2-1 shows the location of each option switch, and describes the function and application of each option.

Electrical Connections

The following paragraphs describe the power line, business equipment and private line connections to the DeskTop 56/64.

AC Power

The wall-mounted transformer is equipped with a cord terminated in a 5-pin DIN plug. Connect this plug to the DIN receptacle labeled POWER, located on the rear of the unit (see *Figure 2-3*). Connect the wall-mounted transformer to an outlet providing the required ac power. The outlet should not be under switch control.

Business Equipment Connections (Data Terminal)

The DTE interface supports business equipment device type, ITU-T V.35. Connect V.35 compatible equipment to the connector labeled Business Equipment. This connector is located on the rear panel (see *Figure 2-2*).

Appendix A describes the signals exchanged through the business equipment interface.

DDS/VF Line Connectors

The DSU is connected to the communications line using the RJ48 modular jack on the rear panel (see *Figure 2-2*).

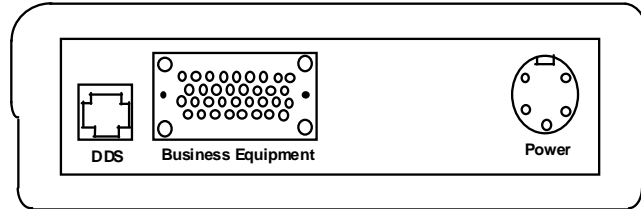

Figure 2-2 Rear Panel Connectors



The TX lines on the modular jack are on pins 1 and 2, and the RX lines are on pins 7 and 8. Pin 1 is on the left and pin 8 is on the right, when viewed from the rear panel.

Table 2-1 Option Location and Selection

S511	
1 Data Rate	DSU operating rate 56 Kbps = OFF 64 Kbps = ON
2 Transmitter Timing	Transmitter timing source. Slave timing (derived from the network) = both OFF.
3	Internal timing (generated by the DSU) = only S511-2ON. External timing (provided by the DTE) = only S511-3ON.
4 Transmit Buffer	Transmit buffer clock source. Internal timing (uses Internal Timing source) = Disabled. External (provided by the DTE) timing = Enabled.
5 Request to Send	Request to Send operation. Normal = OFF. Select RTS-to-CTS delay with S511-6. Force ON RTS and CTS = Forced ON.
6 Clear to Send Delay	RTS-to-CTS delay. S511-5 must be OFF. Normal (3-byte delay) = OFF. Extended (45 ms delay) = ON
7 64K Scrambler	Data scrambler/descrambler. Applicable only at 64 Kbps. Disabled = OFF. Enabled = ON.
8 Anti-Streaming	Auto Anti-Streaming (if RTS remains ON for more than 20 seconds, the DSU forces OFF its primary channel transmitter; after RTS ids OFF for 100 ms, the DSU releases Anti-Streaming). Disabled=OFF. Enabled = ON.

GDC 048R218-000

Table 2-1 Option Location and Selection (Cont.)

S510													
1 Remote Loopback	Remote Loopback test. Enabled = OFF. Disabled = ON.												
2 RL Mode 1 RL Mode 2	Remote Loopback type. Configure both DSUs for the same type.												
3	<table border="0" style="width: 100%; border-collapse: collapse;"> <thead> <tr> <th style="text-align: left;"><u>RL type</u></th> <th style="text-align: center;"><u>S510-2</u></th> <th style="text-align: center;"><u>S510-3</u></th> </tr> </thead> <tbody> <tr> <td>GDC (n/a at 64k)</td> <td style="text-align: center;">Disabled (OFF)</td> <td style="text-align: center;">Disabled (OFF)</td> </tr> <tr> <td>PN 127</td> <td style="text-align: center;">Disabled (OFF)</td> <td style="text-align: center;">Enabled (ON)</td> </tr> <tr> <td>V.54</td> <td style="text-align: center;">Enabled (ON)</td> <td style="text-align: center;">Disabled (OFF)</td> </tr> </tbody> </table>	<u>RL type</u>	<u>S510-2</u>	<u>S510-3</u>	GDC (n/a at 64k)	Disabled (OFF)	Disabled (OFF)	PN 127	Disabled (OFF)	Enabled (ON)	V.54	Enabled (ON)	Disabled (OFF)
<u>RL type</u>	<u>S510-2</u>	<u>S510-3</u>											
GDC (n/a at 64k)	Disabled (OFF)	Disabled (OFF)											
PN 127	Disabled (OFF)	Enabled (ON)											
V.54	Enabled (ON)	Disabled (OFF)											
4 RL Time-out	Remote Loopback time-out. No time-out = OFF. 10-minute time-out = ON.												
5 Self Test Pattern	Self-Test pattern. 511-bit pattern = OFF. 2047-bit pattern = ON.												
6 Front Panel	Front Panel Test Switches Enabled = OFF Disabled = ON												
7 LDM Remote RL	Enabled = Allows RDL to be initiated from the slave-timed unit while in LDM mode.												

3 Operation

Overview

This chapter describes the DSU controls and indicators. You may use these to check for operation of the unit.

Controls and Indicators

Figures 3-1 and 3-2 illustrate the DSU front panel and explain the function of each control and indicator.

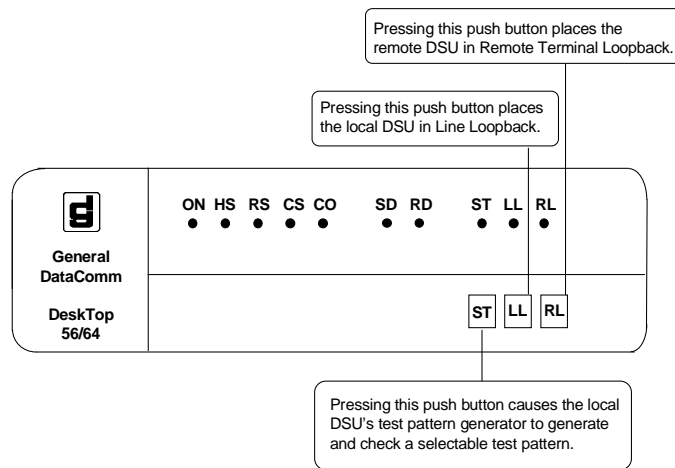

Figure 3-1 Front Panel Push Buttons

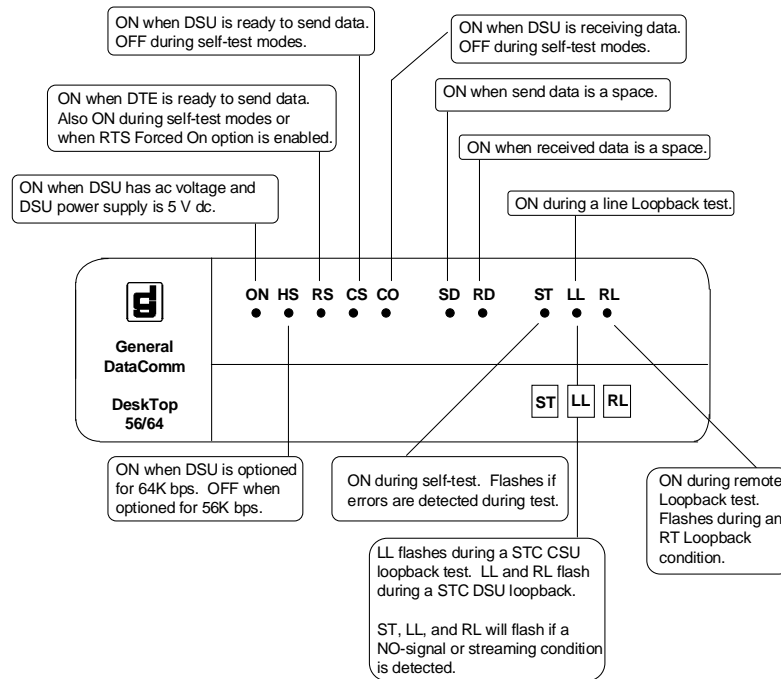

Figure 3-2 Front Panel indicators and Display

GDC 048R218-000

4 Tests

Overview

This chapter describes tests that you can perform as a pre-operational check on installation of the DeskTop 56/64 or whenever you must check its operation.

The SD and RD LEDs may appear to be ON or to flicker, depending on the data rate at which you are testing the unit. When the DSU is operating, the indicators may appear to be solidly ON.



Diagnostics may be controlled from the front panel push buttons or from the Serving Test Center (STC) NOTE depending on the specific test.

You can also use the tests described in this chapter to isolate problems in the data communications system (refer to the fault-isolation sequence in *Figure 4-1*).

Table 4-1 describes the diagnostic test priorities.

Table 4-1 Diagnostic Test Priorities

Priority	Test	Means of Activation
1	CSU Loopback	STC (current reversal)
2	LL/LL-ST	Front Panel
3	DSU Loopback	STC (Codes) (if activated first, has priority over LL/LL- ST)
4	RL/RL-ST	Front Panel
5	ST	Front Panel
6	RT (Remote)	(from remote RL)

Point-to-Point Testing

The following diagrams present test information for point-to-point installations.

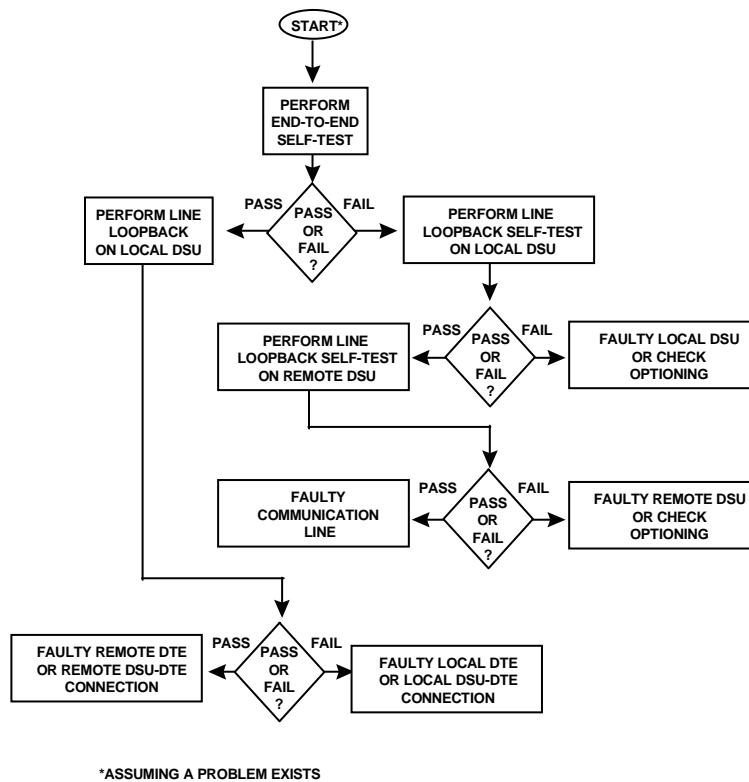

Figure 4-1 Fault-Isolation Sequence

Line Loopback Test

Line Loopback (LL) checks the performance of the DSU and its associated DTE. The DSU disconnects its line transmitter and receiver from the communications line, then connects them together, creating a circuit similar to an Analog Loopback circuit that loops signals from the transmitter through the receiver. It also connects the transmit and receive communications lines together, creating a circuit (the Line Loopback circuit) that loops received signals back over the communications line to the remote DSU. *Figure 4-2* illustrates LL.

While the local DSU is performing Line Loopback, the remote DSU can send a Self-Test pattern to the local DSU, which loops the test pattern back to the remote DSU for verification. This test checks the performance of the remote DSU and the communications line. To perform this test, make arrangements with the remote site personnel before initiating Line Loopback locally.

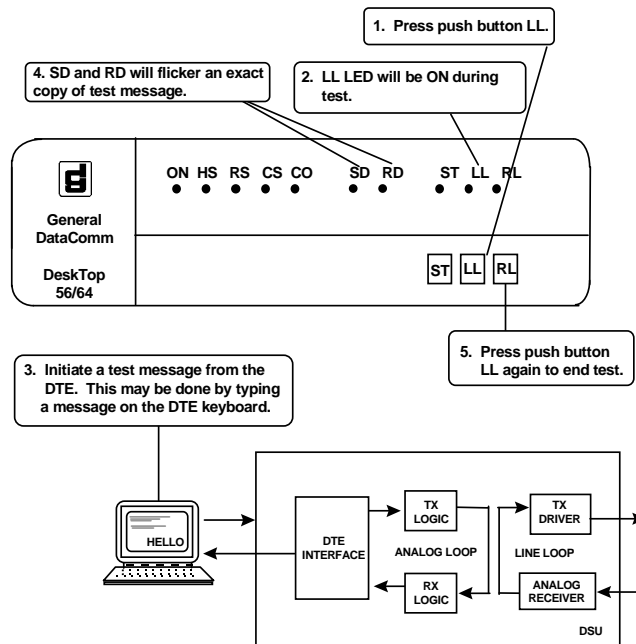

Figure 4-2 Line Loopback Test

Remote Loopback Test

Remote Loopback (RL) checks the performance of the local and remote DSUs, the local DTE, and the communications line. When you initiate this test, the remote DSU enters the RT Loopback condition. The remote DSU disconnects its DTE transmitter and receiver from the DTE interface, then connects them together, creating a circuit that loops the receiver digital output signals to the transmitter input. *Figure 4-3* illustrates RL.

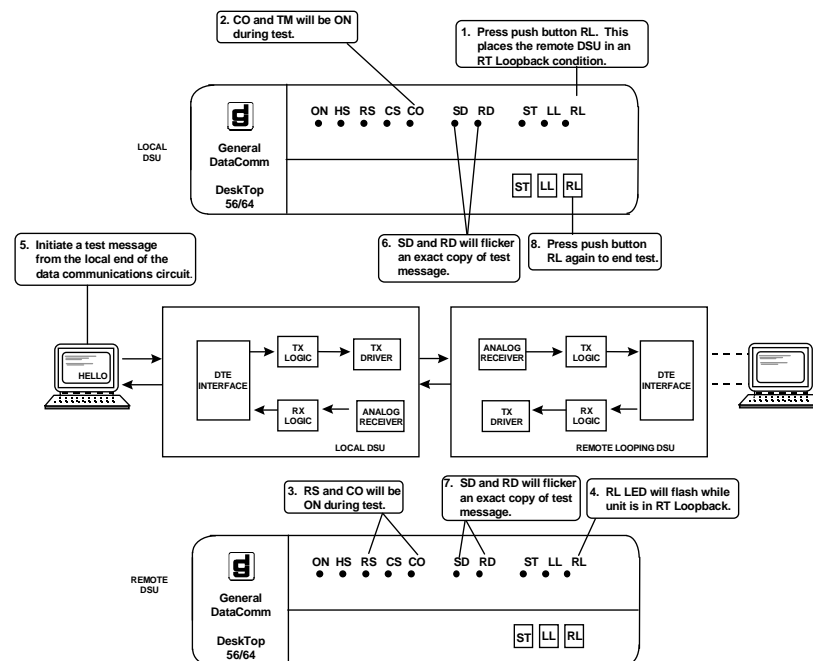

Figure 4-3 Remote Loopback Test

Self-Test

Self-Test allows the DSU to generate a test pattern and monitor the received signal for errors in the received test pattern.

If the DSU detects any errors, the ST LED flashes. You can use Self-Test in place of DTE-generated test messages for the Line Loopback or Remote Loopback tests. *Figures 4-4 through 4-6* illustrate Self-Test.

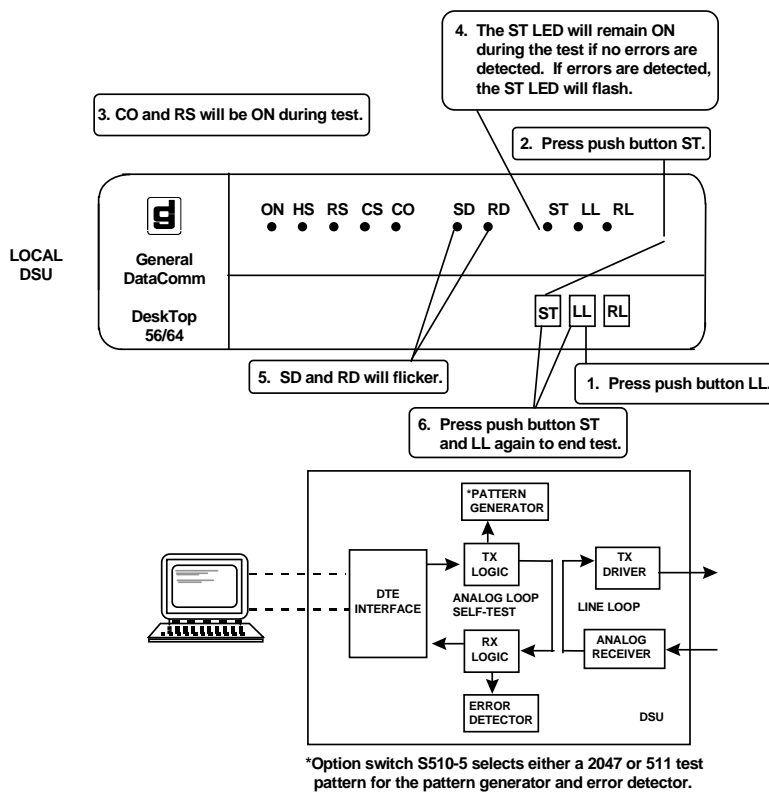

Figure 4-4 Line Loopback Self-Test

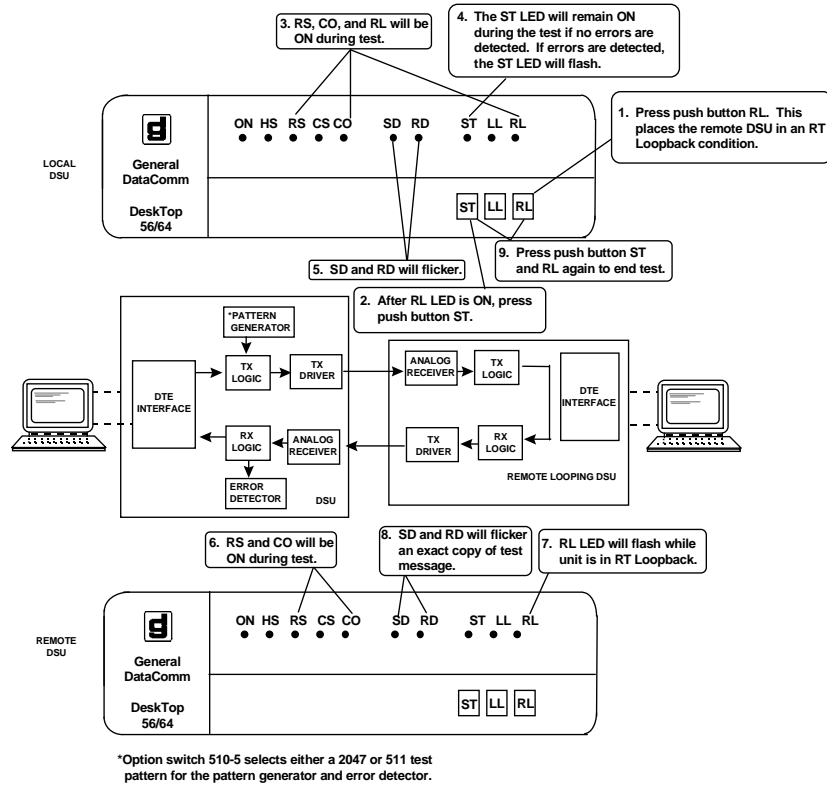

Figure 4-5 Remote Loopback Self-Test

End-to-End Self-Test

You can use the Self-Test with other test features, or independently. In End-to-End Self-Test, the local and remote DSUs exchange Self-Test patterns to check the performance of the communications line and the local and remote DSUs (not including the DSU DTE interfaces).

Figure 4-6 illustrates End-to-End Self-Test.

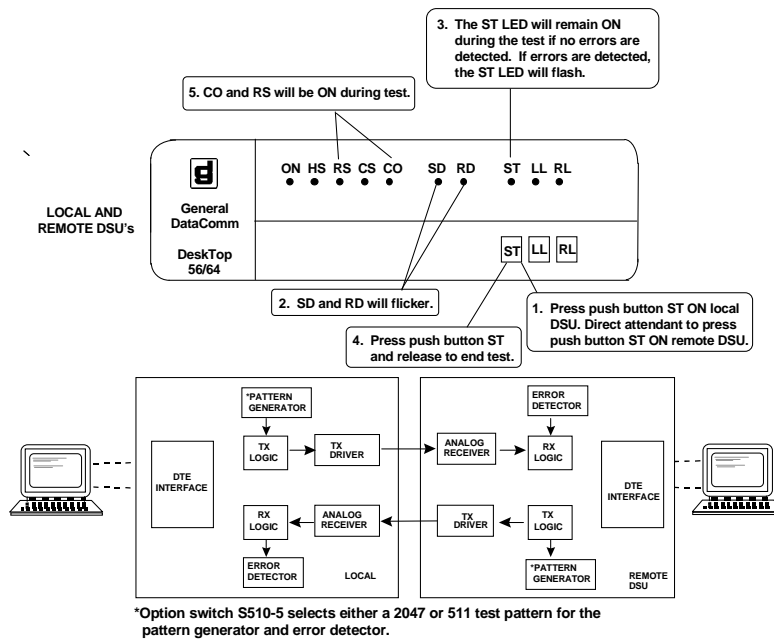

Figure 4-6 End-to-End Self-Test

CSU Loopback Test

The CSU Loopback test is controlled by the Serving Test Center (STC), which reverses the polarity of the sealing current. When the DSU detects the reversed current, it disconnects its line transmitter and receiver from the communications line, then connects them together. It also connects the transmit and receive communications lines together, creating a circuit (the Line Loopback circuit) that loops received signals back over the communications line to the STC. *Figure 4-7* illustrates CSU Loopback.

When it is necessary to isolate a problem, contact the STC and ask them to initiate the CSU Loopback test. Use the test results with the fault-isolation sequence (*Figure 4-1*) to pinpoint a problem.

While the unit is in CSU Loopback, you can send a test message from the local DTE through the local DSU, which loops the message back to the DTE for verification. This test checks the performance of the local DSU, DTE, and DSU-DTE interconnections.

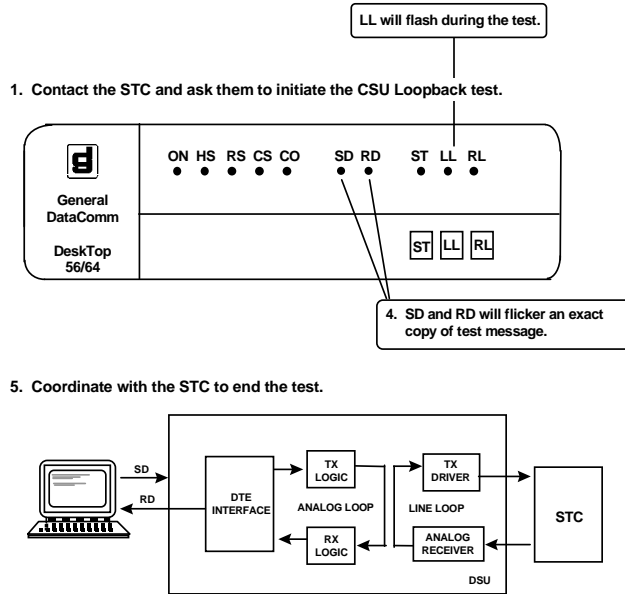

Figure 4-7 CSU Loopback Test

DSU Loopback Test

The DSU Loopback test is controlled by the Serving Test Center (STC), which sends network codes. When the DSU detects the codes, it disconnects its line transmitter and receiver from the communications line, then connects them together, creating a circuit that loops the receiver digital output signals to the transmitter input. *Figure 4-8* illustrates DSU Loopback.

When it is necessary to isolate a problem, contact the STC and ask them to initiate the DSU Loopback test. Use the test results with the fault-isolation sequence (*Figure 4-1*) to pinpoint a problem.

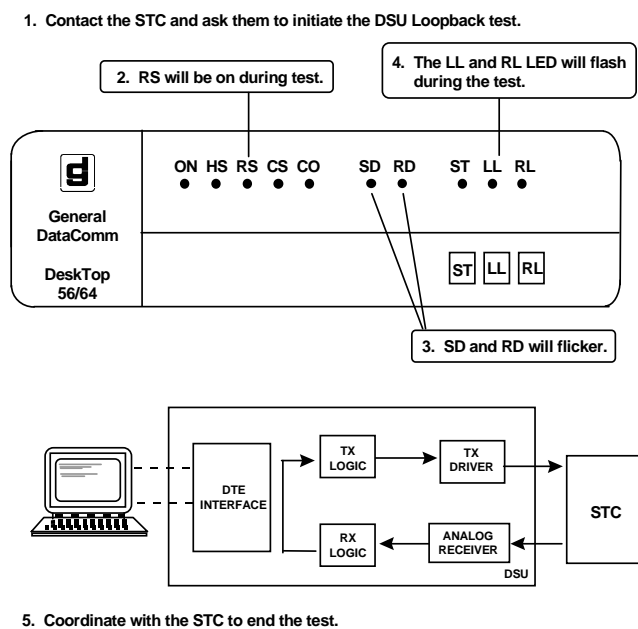

Figure 4-8 DSU Loopback Test

Technical Characteristics

Item	Specifications
Physical	
Height	1.4 in. (3°)
Width	7.4 (188 mm)
Depth	11.0 in. (279 mm)
Weight	1.0 lb. (0.45 kg)
Shipping weight	5.5 lb. (2.5 kg)
Environmental	
Temperature, storage	-40° to 158°F (-40° to 70°C)
Temperature, operating	32° to 122°F (0° to 50°C) (0° to 45°C when Data Rate Adapter is installed)
Humidity, operating	5% to 95% without condensation
Altitude, operating	0 ft to 10,000 ft (0 m to 3,047 m). Derate operating temp. by 1°C/1000 ft above sea level.
Electrical	
Power requirements	
Voltage	117 V ac (+10%, -15%)
Frequency	60 Hz
Power dissipation	5 W nominal
Operation	
DDS	Full- or half-duplex point-to-point, or full duplex multipoint
Customer-owned	Full- or half-duplex, point-to-point
Signal Format	Serial synchronous

Technical Characteristics (Cont.)

Item	Specifications
Electrical	
Data Rate	56000, 64000 bps (synchronous)
Communications Line	DDS or 4-wire, non-loaded metallic lines (19-26 ga)
Terminating impedance	135 ohms \pm 20%
DTE interface	ITU-T V.35
Transmit Power	6.0 dBm, maximum (50% duty cycle, random bipolar sequence, 135-ohm impedance)
RTS-CTS delay (synchronous)	
56000	0.35 ms nominal
64000	Constant Carrier
Timing	Receiver (slave network), internal (DSU) \pm 0.01%, or external (DTE) (accepts external clock up to \pm 0.01%)
Receiver	
Dynamic range	48 dB extended range at 56 K bps
Acquisition time	200 ms
Release time	1 sec nominal
Range	
Line data range	Mileage with 26 ga cable
56 K bps	3.6 mi (5.8 km)
64 K bps	3.2 mi (5.2 km)

Index

- Controls and Indicators, 3-1
- CSU Loopback Test, 4-8
 - DDS/VF Line Connectors, 2-3
- DDS/VF, 2-3
- Diagnostics, 1-2
- DSU Loopback Test, 4-9
- Electrical Connections, 2-3
 - AC power, 2-3
 - Business Equipment (Data Terminal), 2-3
- End-to-End Self-Test, 4-7
- Equipment List, 1-2
- Fault-Isolation Sequence, 4-2
- Features, 1-1
- Front Panel Indicators and Display, 3-2
- Front Panel Push Buttons, 3-1
 - Installation and Line, 2-2
- Glossary of Terms, viii
- Installation Requirements, 2-1
- Installation, 2-1
- Line Loopback Self-Test, 4-3
- Line Loopback Test, 4-3
 - Operation, 3-1
 - Option Location and Selection, 2-4
 - Option Selection, 2-1, 2-3
 - Point-to-Point Testing, 4-2
 - Pre-operational Check, 2-1
 - Installation and Line, 2-2
 - Option Location and Selection, 2-4
- Rear Panel Connectors, 2-3
- Remote Loopback Self-Test, 4-6
- Remote Loopback Test, 4-4
 - Self-Test, 4-5
- Service and Support, iv
- System Description, 1-1
- System Description, 1-1
- Technical Characteristics, A-1
- Tests, 4-1
- Unpacking and Handling, 2-1

Trademarks and Patents

General DataComm, the General DataComm logo and the following are trademarks of General DataComm, Inc. in the United States and other countries: ACCULINE, ANALOOP, AUTOFRAME, BERT 901, DATA-COMM SECURE-PAK, DATALOOP, DIGIDIAL, ENmacs, FASTPRO, FIRST RESPONSE, GDC, GDC APEX, GENERAL DATACOMM X-PRESS, GEN*NET, GEN*PAC, IMAGE*TMS, KILOMUX, LAN*TMS, MEGA*BRIDGE, MEGAMUX, MEGAMUX TMS, MEGANET, MEGA-SPLIT, MEGASWITCH, MEGAVIEW, NETCON, NETSWITCH, NMC, QUIKSHIPPERS, SERVI-CHECK, SERVI-SNAP, WINmacs.

All other products or services mentioned in this document are identified by the trademarks, service marks, or product names as designated by the companies who market those products. Inquiries concerning such trademarks should be made directly to those companies.

Copyright

© 1996 General DataComm, Inc. All rights reserved.

P.O. Box 1299, Middlebury, Connecticut 06762-1299 U.S.A.

This publication and the software it describes contain proprietary information. No part of this document may be copied, photocopied, reproduced, translated or reduced to any electronic or machine-readable format without prior written permission of General DataComm, Inc.

The information in this document is subject to change without notice. General DataComm assumes no responsibility for any damages arising from the use of this document, including but not limited to, lost revenue, lost data, claims by third parties, or other damages. If you have comments or suggestions concerning this manual, please write to Technical Publications or call 1-203-758-1811.

