



INTERNATIONAL TELECOMMUNICATION UNION

ITU-T

V.22

TELECOMMUNICATION
STANDARDIZATION SECTOR
OF ITU

**DATA COMMUNICATION
OVER THE TELEPHONE NETWORK**

**1200 BITS PER SECOND DUPLEX MODEM
STANDARDIZED FOR USE IN THE GENERAL
SWITCHED TELEPHONE NETWORK AND
ON POINT-TO-POINT 2-WIRE LEASED
TELEPHONE-TYPE CIRCUITS**

ITU-T Recommendation V.22

(Extract from the *Blue Book*)

NOTES

1 ITU-T Recommendation V.22 was published in Fascicle VIII.1 of the *Blue Book*. This file is an extract from the *Blue Book*. While the presentation and layout of the text might be slightly different from the *Blue Book* version, the contents of the file are identical to the *Blue Book* version and copyright conditions remain unchanged (see below).

2 In this Recommendation, the expression “Administration” is used for conciseness to indicate both a telecommunication administration and a recognized operating agency.

© ITU 1988, 1993

All rights reserved. No part of this publication may be reproduced or utilized in any form or by any means, electronic or mechanical, including photocopying and microfilm, without permission in writing from the ITU.

Recommendation V.22

1200 BITS PER SECOND DUPLEX MODEM STANDARDIZED FOR USE IN THE GENERAL SWITCHED TELEPHONE NETWORK AND ON POINT-TO-POINT 2-WIRE RELEASED TELEPHONE-TYPE CIRCUITS

(Geneva, 1980; amended at Malaga-Torremolinos, 1984; and at Melbourne, 1988)

1 Introduction

1.1 This modem is intended for use on connections on General Switched Telephone Networks (GSTNs), and on point-to-point circuits when suitably conditioned.

The principal characteristics of this modem are as follows:

- a) duplex operation on 2-wire GSTN and point-to-point leased circuits,
- b) channel separation by frequency division,
- c) differential phase shift modulation for each channel with synchronous line transmission at 600 bauds (nominal),
- d) inclusion of a scrambler,
- e) inclusion of test facilities.

1.2 Recognizing the wide range of application, this Recommendation provides for three alternative configurations. The choice of alternative is a matter for the Administration concerned. The facilities given by the alternatives are:

Alternative A

1200 bit/s synchronous

600 bit/s synchronous (optional)

Alternative B

1200 bit/s synchronous }
600 bit/s synchronous (optional) }

as in Alternative A

1200 bit/s start-stop

600 bit/s start-stop (optional)

Alternative C

1200 bit/s synchronous }
600 bit/s synchronous (optional) }
1200 bit/s start-stop }
600 bit/s start-stop (optional) }

as in Alternative B

An asynchronous mode having capability of handling 1200 bit/s start-stop and asynchronous data at up to 300 bit/s.

The selection of the asynchronous mode is made during the handshaking sequence (see § 6). This gives compatibility between Alternative B and Alternative C.

Note - The possibility of transmitting low speed anisochronous data in Alternatives A and B is left for further study.

2 Line signals

2.1 Carrier and guard tone frequencies

The carrier frequencies shall be 1200 ± 0.5 Hz for the low channel and 2400 ± 1 Hz for the high channel. A guard tone of $1800 \text{ Hz} \pm 20$ Hz, to be transmitted only when the modem is transmitting in the high channel, may be disabled as a national option. An alternative guard tone of 550 ± 20 Hz may be incorporated as a national option. The question of international calls between countries requiring different guard tones is left for further study.

2.2 Data and guard tone line signal levels

The 1800-Hz guard tone shall be at a level of 6 ± 1 dB below the level of the data power in the high channel. The level of the optional 550 Hz tone is for further study. The total power transmitted to line shall be in accordance with Recommendation V.2 and shall be the same for transmission in either channel. Because of the 1800-Hz guard tone, the power level of data signals in the high channel will be approximately 1 dB lower than data signals in the low channel.

2.3 Fixed compromise equalizer

Fixed compromise equalization shall be incorporated in the modem. Such equalization shall be equally shared between transmitter and receiver. The characteristics of the equalizer shall be the responsibility of each Administration to recommend nationally. The possibility of producing compromise characteristics for international implementation is for further study.

2.4 Spectrum and group-delay characteristic

After making allowance for the nominal specified compromise equalizer characteristic, the transmitted line signal shall have a frequency spectrum equivalent to the square root of a raised cosine shaping with a 75% roll-off and within the limits of Figure 1/V.22. Similarly, the group delay of the transmitter output shall be within ± 150 microseconds over the frequency range 900 Hz-1500 Hz (low channel) and 2100 Hz-2700 Hz (high channel). These figures are provisional.

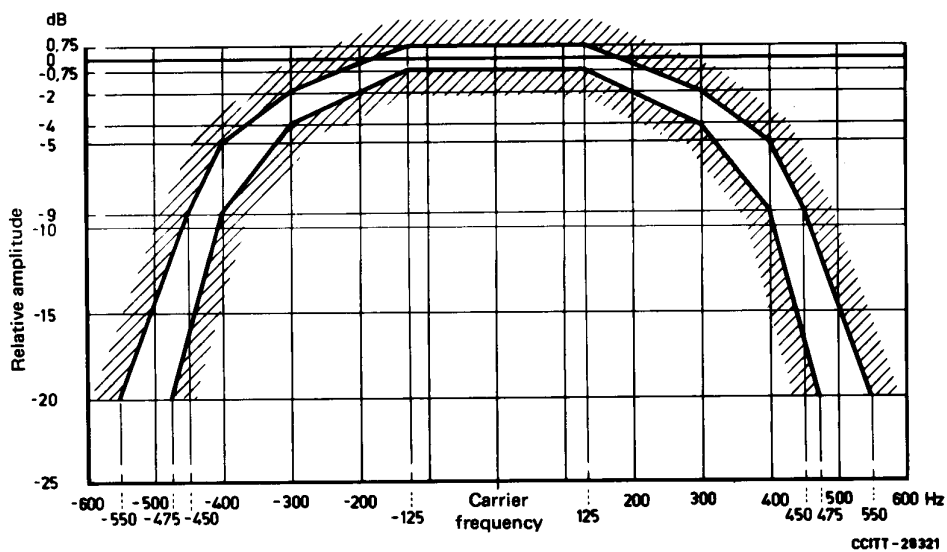

FIGURE 1/V.22

Amplitude limits for transmitted line signal (unequalized)

2.5 Modulation

2.5.1 Data signalling rates

Alternatives A and B: The data signalling rate transmitted to line shall be 1200 bit/s or 600 bit/s $\pm 0.01\%$ with a modulation rate of 600 baud $\pm 0.01\%$.

Alternative C: In Modes i), ii), iii) and iv) (§ 4) the data signalling rates are as in Alternatives A and B. In Mode v), the data signalling rate transmitted to line shall be 1205 1 bit/s with a modulation rate of 602.5 ± 0.5 baud. Optionally in Mode v), the line rate shall be 1223 ± 2 bit/s with a modulation rate of 611.5 ± 1 baud.

2.5.2 Encoding of data bits

2.5.2.1 1200 bits per second

The data stream to be transmitted shall be divided into groups of 2 consecutive bits (dibits). Each dibit shall be encoded as a phase change relative to the phase of the preceding signal element (see Table 1/V.22). At the receiver, the dibits shall be decoded and the bits reassembled in correct order. The left-hand digit of the dibit is the one occurring first in the data stream as it enters the modulator portion of the modem after the scrambler.

TABLE 1/V.22

Dibit values (1200 bit/s)	Bit values (600 bit/s)	Phase change (Modes i, ii, iii, iv)	Phase change (Mode v)
00	0	+ 90°	+ 270°
01	-	0°	+ 180°
11	1	+ 270°	+ 90°
10	-	+ 180°	0°

Note - The phase change is the actual on-line phase shift in the transition region from the centre of one signalling element to the centre of the following signalling element.

2.5.2.2 600 bits per second

Each bit shall be encoded as a phase change relative to the phase of the preceding signal element (see Table 1/V.22).

2.6 Received signal frequency tolerance

Noting that the frequency tolerance of the transmitter carriers is ± 1 Hz or less, and assuming a maximum shift of ± 6 Hz in the connection, the receiver shall be able to accept errors of at least ± 7 Hz in the received frequencies.

3 Interchange circuits

3.1 Table of interchange circuits (Note 1 of Table 2/V.22)

Essential and optional interchange circuits are listed in Table 2/V.22.

TABLE 2/V.22

Interchange circuits (Note 1)

Interchange circuit		Notes
No.	Description	
102	Signal ground or common return	
103	Transmitted data	
104	Received data	
105	Request to send	Note 2
106	Ready for sending	
107	Data set ready	
108/1	Connect data set to line	Note 3
108/2	Data terminal ready	Note 3
109	Data channel received line signal detector	
111	Data signalling rate selector (DTE source)	
113	Transmitter signal element timing (DTE source)	Note 4
114	Transmitter signal element timing (DCE source)	Note 5
115	Receiver signal element timing (DCE source)	Note 6
125	Calling indicator	Note 6
140	Loopback/maintenance test	Note 7
141	Local loopback	
142	Test indicator	

Note 1 - All essential interchange circuits and any others which are provided shall comply with the functional and operational requirements of Recommendation V.24. All interchange circuits provided shall be properly terminated in the data terminal equipment and in the data circuit-terminating equipment in accordance with the appropriate Recommendation for electrical characteristics (see § 3.5).

Note 2 - Some automatic calling equipments are designed to emit a calling tone to line by turning ON circuit 105 to the calling modem. The general switched telephone network (GSTN) constant carrier handshake is such that no calling tone will be emitted by the V.22 modem when used with these equipments.

Note 3 - This circuit shall be capable of operation as circuit 108/1 or 108/2 depending on its use.

Note 4 - This circuit is optional if only the 1200 bit/s speed [modes i) and ii) as defined in §§ 4.1, 4.2 and 4.3] is provided in the modem. If the 600 bit/s speed [modes iii) and iv)] is also provided, this circuit is essential.

Note 5 - When the modem is not operating in a synchronous mode any signals on this circuit shall be disregarded. Many DTEs operating in an asynchronous mode do not have a generator connected to this circuit.

Note 6 - When the modem is not operating in a synchronous mode, this circuit shall be clamped to the OFF condition. Many DTEs operating in an asynchronous mode do not terminate this circuit.

Note 7 - This circuit is for use with the general switched telephone network only.

3.2 *Circuits 106 and 109 response times* (see Table 3/V.22)

Circuit 106 response times are from the application of an ON or OFF condition on circuit 105. See also § 6 for operating sequences.

TABLE 3/V.22

	Constant carrier	Controlled carrier
<i>Circuit 106</i>		
OFF to ON	≤ 2 ms	210 to 275 ms
ON to OFF	≤ 2 ms	≤ 2 ms
<i>Circuit 109</i>		
OFF to ON	105 to 205 ms	105 to 205 ms
ON to OFF	10 to 24 ms	10 to 24 ms

3.3 *Circuit 109 thresholds*

High channel threshold:

greater than -43 dBm circuit 109 ON
less than -48 dBm circuit 109 OFF

Low channel threshold:

greater than -43 dBm circuit 109 ON
less than -48 dBm circuit 109 OFF

The condition of circuit 109 between the ON and OFF levels is not specified, except that the signal detector shall exhibit a hysteresis action such that the level at which the OFF to ON transition occurs shall be at least 2 dB greater than for the ON to OFF transition.

Circuit 109 thresholds are specified at the input to the modem excluding the effects of the compromise equalizer.

Circuit 109 shall not respond to the 1800-Hz or 550-Hz guard tones, or the 2100-Hz (nominal) answer tone during the handshake sequence.

Administrations are permitted to change these thresholds where transmission conditions are known.

3.4 *Circuit 111 and data rate control*

Data rate selection may be by switch (or similar means) or by circuit 111 or a combination of both.

The ON condition on circuit 111, where provided, shall select 1200 bit/s operation and the OFF condition shall select 600 bit/s operation.

3.5 *Electrical characteristics of interchange circuits*

Use of electrical characteristics conforming to Recommendation V.28 is recommended together with the connector and pin assignment plan specified by ISO 2110.

Note - Manufacturers may wish to note that the long-term objective is to replace electrical characteristics specified in Recommendation V.28, and that Study Group XVII has agreed that the work shall proceed to develop a more efficient, all-balanced, interface for the V-Series application which minimizes the number of interchange circuits.

3.6 *Fault condition of interchange circuits*

(See Recommendations V.28, § 7 for association of the receiver failure detection types.)

- 3.6.1 The DTE should interpret a fault condition on circuit 107 as an OFF condition using failure detection type 1.
- 3.6.2 The DCE should interpret a fault condition on circuits 105 and 108 as an OFF condition using failure detection type 1.
- 3.6.3 All other circuits not referred to above may use failure detection type 0 or 1.

4 **Modes of operation over the DTE/DCE interface**

4.1 *Alternative A*

The modem can be configured for the following modes of operation:

Mode i) 1200 bit/s \pm 0.01% synchronous

Mode iii) 600 bit/s \pm 0.01% synchronous (optional).

In these modes of operation, the modem shall accept synchronous data from the DTE on circuit 103 under control of circuit 113 or circuit 114. The data shall then be scrambled in accordance with § 5 and then passed to the modulator for encoding in accordance with § 2.5.2.

In addition to standard V.24 transmitter timing arrangements, the modem shall provide capabilities to derive transmit signal element timing from receiver signal element timing.

4.2 *Alternative B*

The modem can be configured for the following modes of operation:

Mode i) 1200 bit/s \pm 0.01% synchronous

Mode ii) 1200 bit/s start-stop 8, 9, 10 or 11 bits per character

(Mode iii) 600 bit/s \pm 0.01% synchronous optional

(Mode iv) 600 bit/s start-stop 8, 9, 10 or 11 bits per character

} optional

The synchronous modes are as given in Alternative A.

In the start-stop modes, the modem shall accept a data stream of start-stop characters from the DTE at a nominal rate of 1200 or 600 bits per second. The start-stop data to be transmitted shall be converted, in conformity with Recommendation V.14, to a synchronous data stream suitable for transmission in accordance with § 4.1

Demodulated data shall be decoded in accordance with § 2.5.2, then descrambled in accordance with § 5 and then passed to the converter in conformity with Recommendation V.14 for regaining the data stream of start-stop characters.

The intracharacter signalling rate provided to the DTE over circuit 104 shall be in the ranges given in Table 4/V.22 when operating in the basic or in the extended signalling rate ranges, respectively.

TABLE 4/V.22

Intracharacter signalling rate range

Data rate	Signalling rate range	
	Basic	Extended
600 bit/s	600 to 606 bit/s	600 to 614 bit/s
1200 bit/s	1200 to 1212 bit/s	1200 to 1227 bit/s

4.3 *Alternative C*

The modem can be configured for the following modes of operation.

Mode i) 1200 bit/s \pm 0.01% synchronous

Mode ii) 1200 bit/s start-stop 8, 9, 10 or 11 bits per character

(Mode iii) 600 bit/s \pm 0.01% synchronous optional

(Mode iv) 600 bit/s start-stop 8, 9, 10 or 11 bits per character

} optional

Mode v) An asynchronous mode having capability of handling 1200 bit/s start-stop and anisochronous data at up to 300 bit/s.

Modes i) to iv) are as given in Alternative B.

4.3.1 *Basic modes*

In Alternative C, the modem shall incorporate Modes i), ii), iii) and iv) given in Alternative B, plus Mode v), in which the modem transmitter sends data at a rate always greater than the input data rate, and thus disables the receiver buffer. The GSTN handshaking sequence allows automatic selection of Modes ii) or v). Modes i), iii) and iv) must be selected at installation. On leased circuits there is no automatic mode selection. The line encoding for specific dibit values is described in Table 1/V.22.

4.3.2 *Transmitter*

In Mode v), the modem shall accept a data stream of start-stop characters from the DTE at a nominal rate of a 0 to 300 bit/s or 1200 bit/s automatically. The transmitter buffer that converts incoming data to a synchronous data stream at 1205 bit/s or 1223 bit/s shall:

- a) start its asynchronous bit counter on either data transition,
- b) always transmit the last bit received over circuit 103 after the bit counter has elapsed,
- c) sample incoming data during the bit count at 1205 Hz or 1223 Hz depending upon line rate.

This will assure that incoming data at 0 to 300 bit/s shall pass through the buffer with a maximum introduced distortion of 25% at 300 bit/s (and 12.5% at 150 bit/s), and that break signals pass through the buffer unchanged.

The length and structure of incoming characters shall be the same as given in Alternative B. Within Mode v) at 1200 bit/s asynchronous, two adjacent character formats, e.g. 9- and 10-bit character, can be handled automatically. As in Alternative B, the modem shall derive its line signal clock from internal clock circuits, or alternatively, from receiver signal element timing, as an installation option.

4.3.3 Basic signalling rate range

In Mode v), the intracharacter signalling rate provided by the DTE on circuit 103 must be:

1205 bit/s line rate 0 to 301 bit/s and 1170 to 1204 bit/s
 1223 bit/s line rate 0 to 305 bit/s and 1190 to 1221 bit/s

Selection of line rate is made in the transmitter by installer option and automatically detected in the receiver.

5 Scrambler and descrambler

5.1 Scrambler

A self synchronizing scrambler having the generating polynomial $1 \oplus x^{-14} \oplus x^{-17}$ shall be included in the modem transmitter. The message data sequence applied to the scrambler shall be effectively divided by the generating polynomial. The coefficients of the quotients of this division, taken in descending order, form the data sequence which shall appear at the output of the scrambler. The scrambler output data sequence

$$D_s = D_i \oplus D_s \cdot x^{-14} \oplus D_s \cdot x^{-17}$$

where

D_s is the data sequence at the output of the scrambler

D_i is the data sequence applied to the scrambler

\oplus denotes modulo 2 addition

\cdot denotes binary multiplication

Figure 2/V.22 shows a suitable implementation.

To prevent occasional inadvertent instigation of remote loop 2 caused by scrambler lockup, circuitry shall be included to detect a sequence of 64 consecutive ones at the scrambler output (D_s) and, if detected, invert the next input to the scrambler, D_i . This circuitry will not operate during handshaking or during the instigation of remote loop 2.

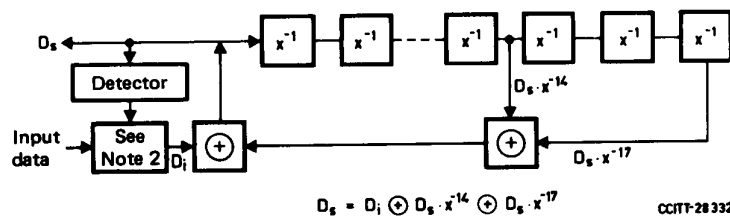

Note 1 Marks (binary 1) and spaces (binary 0) at the V.24 interface correspond to ones and zeros, respectively, in this logic diagram.

Note 2 Circuitry shall be included to detect a sequence of 64 consecutive binary ones at the scrambler output (D_s) and, if detected, invert the next input to the scrambler (D_i).

FIGURE 2/V.22

Scrambler

5.2 Descrambler

A self synchronizing descrambler having the polynomial $1 \oplus x^{-14} \oplus x^{-17}$ shall be provided in the modem receiver. The message data sequence produced after demodulation shall be effectively multiplied by the generating polynomial $1 \oplus x^{-14} \oplus x^{-17}$ to form the descrambled message. The coefficients of the recovered message sequence taken in descending order form the output data sequence D_o , which is given by

$$D_o = D_s (1 \oplus x^{-14} \oplus x^{-17})$$

Figure 3/V.22 shows a suitable implementation.

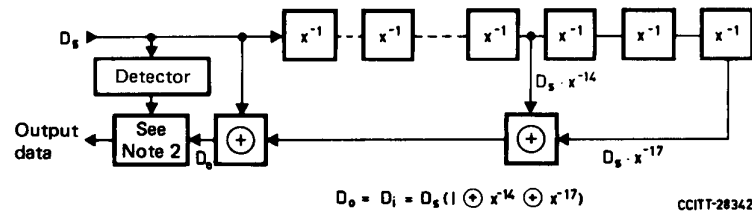

Note 1 - Marks (binary 1) and spaces (binary 0) at the V.24 interface correspond to ones and zeros, respectively, in this logic diagram.

Note 2 - Circuitry may be included to detect a sequence of 64 consecutive ones at the input to the descrambler (D_s) and, if detected, invert the next output from the descrambler (D_o). This detector should not begin operating until the handshaking sequence is complete. If this circuitry is included, detection of the initiation signal described in § 7.1.1 (unscrambled binary ones) should be performed at the point D_o .

FIGURE 3/V.22

Descrambler

6 Operating sequences

6.1 Channel and operating mode selection

On the general switched telephone network, the modem at the calling data station shall transmit in the low channel and receive in the high channel (call mode). The modem at the answering data station shall receive in the low channel and transmit in the high channel (answer mode).

Where calls are established on the GSTN by operators, bilateral agreement between users on channel allocation will be necessary. On point-to-point leased circuits, channel allocation will be by bilateral agreement between Administrations or users. In these cases the method of selection of call or answer mode is a national matter.

On point-to-point leased circuits, selection of Modes i) to v) will be by bilateral agreement between Administrations or users. The method of selection is a national matter.

6.2 V.25 automatic answering sequence

The V.25 automatic answering sequence shall be transmitted from the answer mode modem on international GSTN connections. The transmission of the sequence may be omitted on point-to-point leased circuits or on national connections on the GSTN, where permitted by the Administration.

6.3 Operating sequences for Alternatives A and B

6.3.1 GSTN - constant carrier

The means of achieving initial synchronism between the call mode modem and the answer mode modem on international GSTN connections is shown in Figure 4/V.22. The alternative handshake without V.25 automatic answering is shown in Figure 5/V.22.

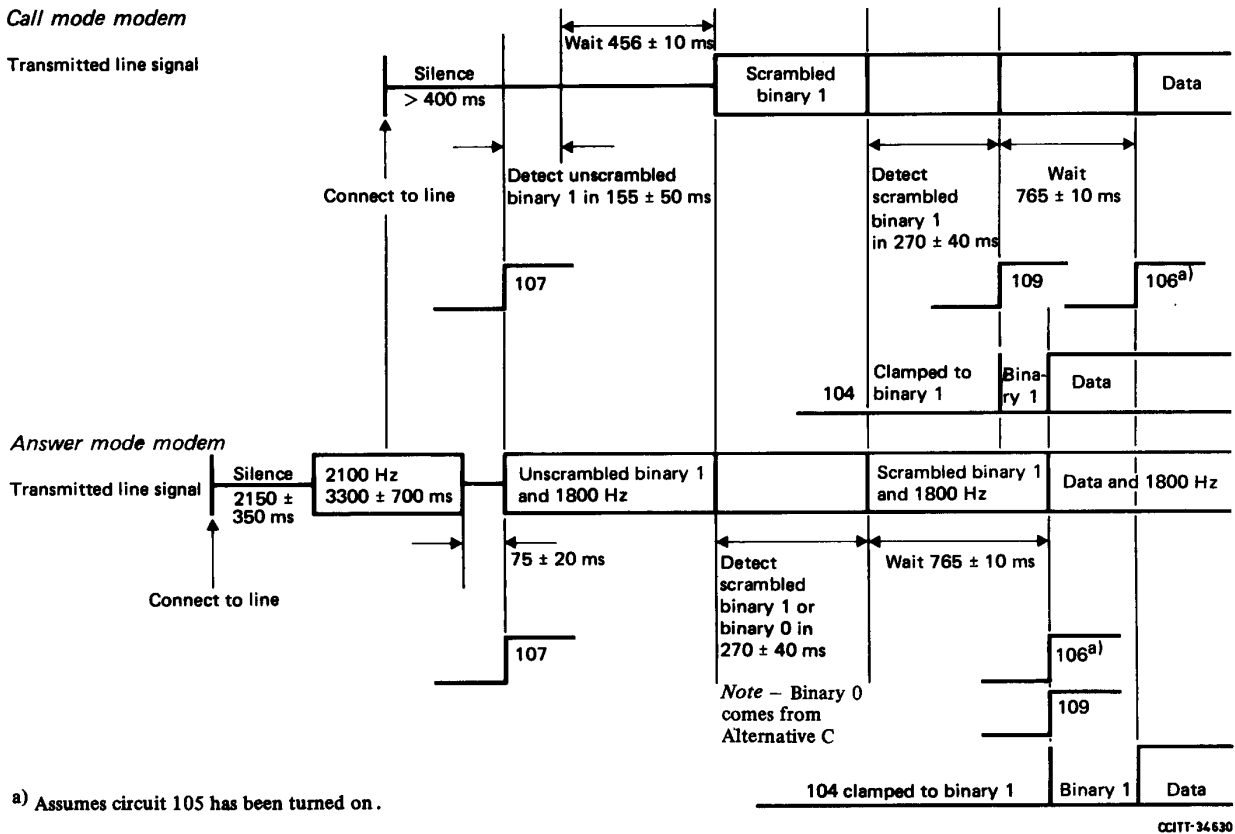
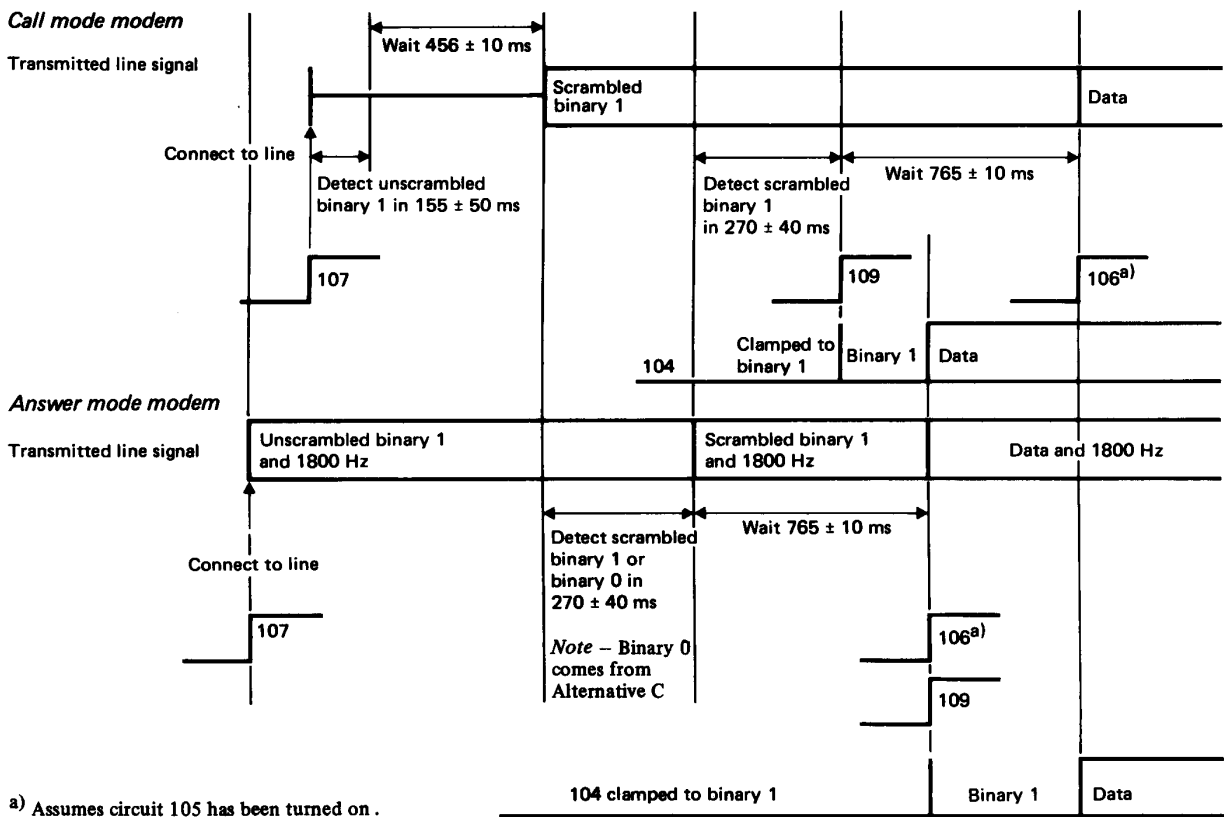

FIGURE 4/V.22

Handshake sequence for Alternatives A and B (with V.25 auto-answering)



CCITT-34640

FIGURE 5/V.22

Handshake sequence for Alternatives A and B (without V.25 auto-answer sequence)

6.3.1.1 *Call mode modem*

Once the call mode modem has connected to line, it shall be conditioned to receive signals in the high channel and shall apply an ON condition to circuit 107 in accordance with Recommendation V.25. The modem shall remain silent until unscrambled binary 1 is detected for 155 ± 50 ms, and after waiting for 456 ± 10 ms shall transmit scrambled binary 1 in the low channel. Upon detecting scrambled binary 1 in the high channel in 270 ± 40 ms, the modem shall turn circuit 109 ON, then wait a further 765 ± 10 ms. Circuit 106 shall then respond to the condition of circuit 105 according to Table 3/V.22 constant carrier mode. When circuit 106 is OFF, circuit 103 shall be clamped to the binary 1 condition.

Note - Manufacturers may wish to note that in certain countries, for national purposes, modems are in service which emit an answering tone of 2225 Hz instead of unscrambled binary 1.

6.3.1.2 *Answer mode modem*

Once the answer mode modem has connected to line and immediately following the V.25 answer sequence, the modem shall be conditioned to receive signals in the low channel. It shall then apply an ON condition to circuit 107 and transmit unscrambled binary 1. Upon detecting scrambled binary 1 or 0 in the low channel in 270 ± 40 ms, the modem shall transmit scrambled binary 1 in the high channel, and after waiting for 765 ± 10 ms, apply an ON condition to circuit 109. Circuit 106 shall then respond to the condition of circuit 105 according to Table 3/V.22, constant carrier mode. When circuit 106 is OFF, circuit 103 shall be clamped to the binary 1 condition.

Where both modems are manually connected to line this sequence will apply irrespective of whether the call or answer mode modem is connected to line first.

After completion of the handshake sequence, any inadvertent loss and reappearance of the received line signal should not cause another handshake sequence to be generated. Circuit 109 should respond with the response times given in Table 3/V.22.

6.3.2 *GSTN and point-to-point leased circuits - controlled carrier*

Once an ON condition has been applied to circuit 105 by the DTE, the modem shall transmit a synchronizing signal corresponding to binary 1 applied to circuit 103. The ON condition shall be applied to circuit 106, 210 to 275 ms after starting to transmit the synchronizing signal. The receiving modem shall establish timing and descrambler synchronization and then turn circuit 109 ON in 105 to 205 ms.

Each direction of transmission shall be independently controlled.

Note - Controlled carrier operation on GSTN is optional. For circuits with echo suppressors, controlled carrier working is not recommended.

6.4 *Operating sequence for Alternative C*

Refer to Figure 6/V.22.

6.4.1 *GSTN - constant carrier*

6.4.1.1 *Call mode modem*

If configured for Modes i), iii), or iv), the handshake sequence proceeds as for Alternative B. If configured for Mode v), the handshaking sequence shall automatically select Mode ii) or v). This sequence shall be as follows:

Once the call mode modem has connected to line, it shall be conditioned to receive signals in the high channel and shall apply an ON condition to circuit 107 in accordance with Recommendation V.25. The modem shall remain silent until unscrambled binary 1 [Mode ii)] is detected for 155 ± 50 ms and after waiting for 456 ± 10 ms shall transmit scrambled binary 0 [Mode ii)] in the low channel. Upon detecting scrambled binary 1 [Mode ii)] in the high channel within 270 ± 40 ms, the modem shall turn circuit 109 ON, enter Mode ii), then wait a further 765 ± 10 ms. Upon detecting scrambled binary 1 [Mode v)] in the high channel in 270 ± 40 ms, the modem shall turn ON circuit 109, enter Mode v), then wait a further 765 ± 10 ms. Circuit 106 shall then respond to the condition of circuit 105 according to Table 3/V.22 constant carrier mode. When circuit 106 is OFF, circuit 103 shall be clamped to the binary 1 condition.

See also the note in § 6.3.1.1.

6.4.1.2 *Answer mode modem, Mode v)*

Once the answer mode modem has connected to line and immediately following the V.25 answer sequence, the modem shall be conditioned to receive signals in the low channel. It shall then apply an ON condition to circuit 107 and transmit unscrambled binary 1 [Mode ii)].

If scrambled binary 0 [Mode ii)] is detected in the low channel for 270 ± 40 ms, the modem shall enter Mode v), transmit scrambled binary 1 [Mode v)] in the high channel and after waiting for 765 ± 10 ms apply an ON condition to circuit 109.

If scrambled binary 1 [Mode ii)] is detected in the low channel for 270 ± 40 ms, the modem shall enter Mode ii), transmit scrambled binary 1 [Mode ii)] in the high channel and after waiting for 765 ± 10 ms apply an ON condition to circuit 109.

Circuit 106 shall respond to the condition of circuit 105 according to Table 3/V.22 constant carrier mode. When circuit 106 is OFF circuit 103 shall be clamped to the binary 1 condition.

6.4.2 *GSTN and point-to-point leased circuits*

Controlled carrier operation as in § 6.3.2.

Call mode modem

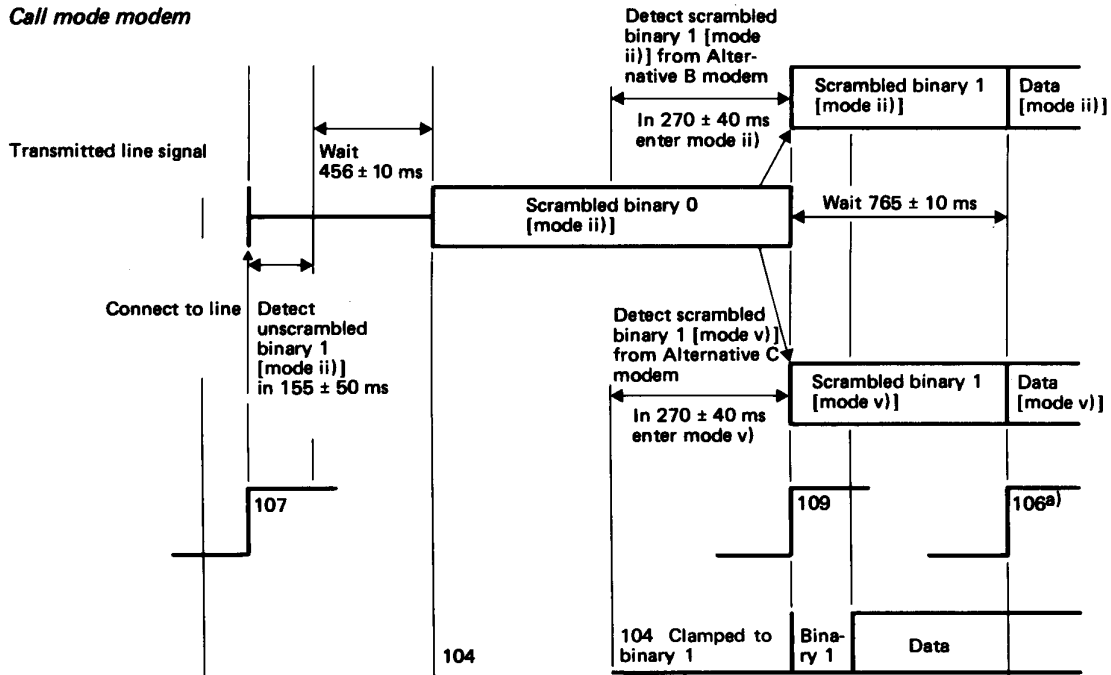

Answer mode modem

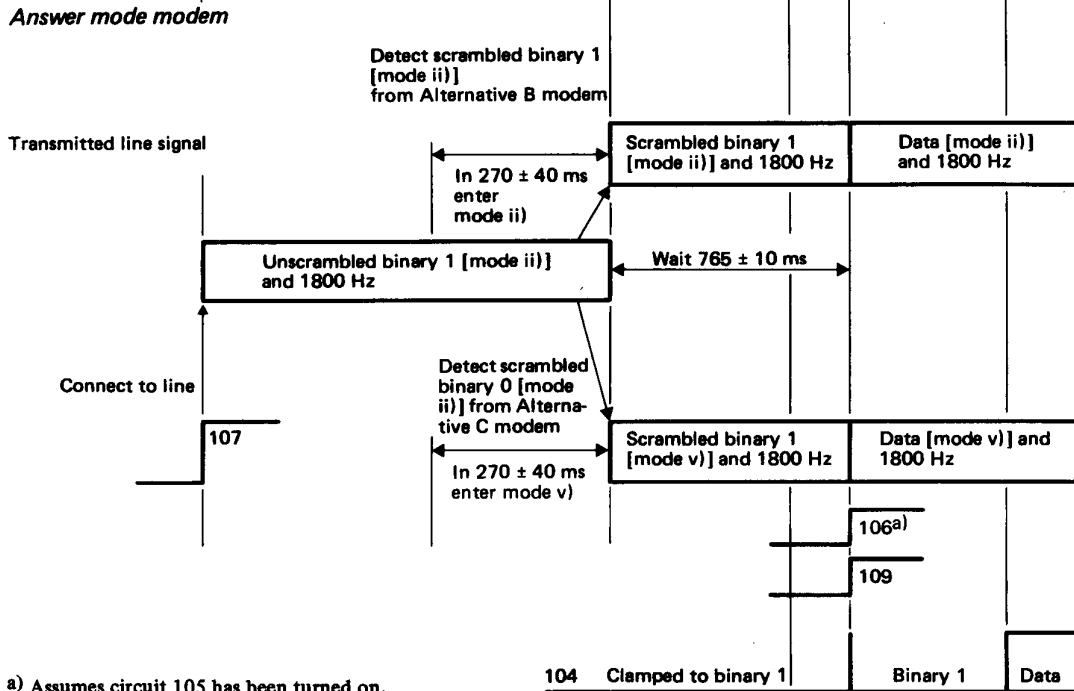

a) Assumes circuit 105 has been turned on.

FIGURE 6/V.22

Handshake sequence for Alternative C (without V.25 auto-answer sequence)

7 Testing facilities

7.1 Test loops

Test loops 2 (local and remote) and 3 as defined in Recommendation V.54 shall be provided. Interface operation shall be as defined in Recommendation V.54. Instigation and termination sequences are not compatible with Recommendation V.54.

7.1.1 Instigation of remote loop 2

Signals controlling the application of remote loop 2 may only be transmitted after the synchronizing andshake has been completed.

As in Recommendation V.54, the modems are referred to as modem A and modem B.

When modem A is instructed to instigate a remote loop 2, the modem shall transmit an initiation signal of unscrambled binary 1.

Modem B shall detect 154-231 ms of the initiation signal, and then transmit to modem A scrambled alternate binary ones and zeros (reversals) at 1200 bit/s (or 600 bit/s).

Modem A shall detect 231-308 ms of scrambled reversals, cease transmission of the initiation signal, and then transmit scrambled binary 1 at 1200 bit/s (or 600 bit/s).

Modem B shall detect the loss of initiation signal and activate loop 2 within modem B.

Modem A, upon receiving 231-308 ms of scrambled binary 1 shall indicate to the DTE that it may begin sending test messages.

7.1.2 Termination of remote loop 2

When modem A is instructed to terminate a remote loop 2, the line signal shall be suppressed for a period of 77 ± 10 ms, after which transmission shall be restored.

Modem B detects the loss of line signal in 17 ± 7 ms and detects the reappearance of the signal within 155 ± 50 ms, after which it returns to normal operation.

7.2 Self tests

7.2.1 Self test end-to-end

Upon activation of the self-test switch an internally generated data pattern of alternate binary ones and zeros (reversals) at the selected bit rate shall be applied to the scrambler. An error detector, capable of identifying errors in a stream of reversals shall be connected to the output of the descrambler. The presence of errors shall be indicated by a visual indicator. All generating interchange circuits except 114 (if used), 115 and 142 shall be clamped to the binary 1 or OFF condition. If circuit 113 is used, the DCE shall disregard this interchange circuit and use its internal clock.

7.2.2 Self test with loop 3

Loop 3 shall be applied to the modem as defined in Recommendation V.54. The self-test switch shall be activated and DCE operation shall be as in § 7.2.1.

7.2.3 Self test with remote loop 2

The modem shall be conditioned to instigate a loop 2 at the remote modem as specified in § 7.1. The self-test switch shall be activated and DCE operation shall be as in § 7.2.1.

It shall be possible to perform the above tests (§§ 7.2.1, 7.2.2 and 7.2.3) with or without the DTE connected to the modem. These tests employ an internally generated data pattern that is controlled by a switch on the DCE.

7.2.4 During any self-test mode, interchange circuits 103, 105 and 108 will be ignored. Note that self tests do not test asynchronous-to-synchronous converter circuits in either the transmitter or receiver.

Note - Inclusion of remote loop signalling according to Recommendation V.54 is for further study.