



INTERNATIONAL TELECOMMUNICATION UNION

CCITT

Q.955

THE INTERNATIONAL
TELEGRAPH AND TELEPHONE
CONSULTATIVE COMMITTEE

**STAGE 3 DESCRIPTION FOR
SUPPLEMENTARY SERVICES
USING DSS 1**

**STAGE 3 DESCRIPTION FOR
COMMUNITY OF INTEREST SUPPLEMENTARY
SERVICES USING DSS 1**

SECTION 1 – CLOSED USER GROUP

Recommendation Q.955



Geneva, 1992

FOREWORD

The CCITT (the International Telegraph and Telephone Consultative Committee) is a permanent organ of the International Telecommunication Union (ITU). CCITT is responsible for studying technical, operating and tariff questions and issuing Recommendations on them with a view to standardizing telecommunications on a worldwide basis.

The Plenary Assembly of CCITT which meets every four years, establishes the topics for study and approves Recommendations prepared by its Study Groups. The approval of Recommendations by the members of CCITT between Plenary Assemblies is covered by the procedure laid down in CCITT Resolution No. 2 (Melbourne, 1988).

Recommendation Q.955, § 1 was prepared by Study Group XI and was approved under the Resolution No. 2 procedure on the 4th of February 1992.

CCITT NOTE

In this Recommendation, the expression "Administration" is used for conciseness to indicate both a telecommunication Administration and a recognized private operating agency.

© ITU 1992

All rights reserved. No part of this publication may be reproduced or utilized in any form or by any means, electronic or mechanical, including photocopying and microfilm, without permission in writing from the ITU.

Recommendation Q.955

STAGE 3 DESCRIPTION FOR COMMUNITY OF INTEREST SUPPLEMENTARY SERVICES USING DSS 1

1 Closed User Group (CUG)

1.1 Definition

The supplementary service Closed User Group (CUG) enables users to form groups, to and from which access is restricted. A specific user may be a member of one or more CUGs. Members of a specific CUG can communicate among themselves but not, in general, with users outside the group. Specific CUG members can have additional capabilities that allow them to originate calls outside the group, and/or to receive calls from outside the group. Specific CUG members can have additional restrictions that prevent them from originating calls to other members of the CUG, or from receiving calls from other members of the CUG.

1.2 Description

1.2.1 General description

Essentially normal call establishment procedures apply, but additionally, to provide CUG service, the network analyses the call request from the calling user in conjunction with the CUG attributes associated with both the calling and called users (as identified by their ISDN numbers). As a result of this analysis the call either fails for CUG reasons or is allowed to proceed.

Note – In the case where a user has subscribed to the DDI supplementary service, attributes are associated with that part of the ISDN number which the network can recognize or with the default number valid for that access.

The network provider may define the maximum number of CUGs of which a user can be a member.

Since the fundamental purpose of the CUG service is to prevent certain connections, it is necessary to strictly control interactions with some other supplementary services to protect CUG integrity.

1.2.2 Specific terminology

1.2.2.1 CUG manager

The CUG manager is the authority representing the interests of all the members of a CUG. By planning and controlling the membership and members' options, the manager can provide the overall CUG service expected by the members as a whole.

The CUG manager need not be a CUG member and the concept has no signalling implications.

1.2.2.2 CUG index

The CUG index is a parameter used by the calling user to select a particular CUG when originating a call. The index is also used by the network to indicate to the called user the CUG from which an incoming call has originated.

This index has only local significance, i.e. the index used by the calling user will, in general, be different from the index used by the called user to identify the same CUG.

1.2.2.3 CUG interlock code

This is a means of identifying CUG membership within the network. At the calling side, if a CUG match exists, the CUG index identifying a CUG maps to the CUG interlock code for that CUG. If a CUG match exists at the called side, the CUG interlock code identifying a CUG maps to the CUG index representing that CUG.

CUG interlock code is not an access concept, but is used for clarity during the descriptions of signalling procedures and flows.

1.2.2.4 **preferential CUG**

A CUG user subscribing to preferential CUG nominates a CUG index which the network uses to identify the required CUG in the absence of a CUG index being included in the outgoing call request.

A preferential CUG applies to an ISDN number (or to an ISDN number/service – see § 1.3.1) and not to a specific CUG.

1.2.2.5 **CUG only service**

A user with CUG only services is limited to making calls to, and receiving calls from, members of those CUGs of which the user is a member.

1.2.2.6 **outgoing calls barred within the CUG**

This restriction means that a CUG user cannot make CUG calls to members of those CUGs of which the user is a member with the “outgoing calls” barring within the CUG option.

1.2.2.7 **outgoing access**

Outgoing access allows a CUG user, in addition to the CUG only service (with or without outgoing calls barred within the CUG), to make calls to all other non-CUG users and also to those other CUG users that allow incoming access.

An outgoing access arrangement applies to an ISDN number (or to an ISDN number/service – see § 1.3.1) and not to a specific CUG.

1.2.2.8 **incoming calls barred within the CUG**

This restriction means that a CUG user cannot receive CUG calls from members of those CUGs of which the user is a member with the “incoming calls” barring within the CUG option.

1.2.2.9 *Incoming access*

Incoming access allows a CUG user, in addition to the CUG only service (with or without incoming calls barred within the CUG), to receive calls from all other non-CUG users and also from those other CUG users that allow outgoing access.

An incoming access arrangement applies to an ISDN number (or to an ISDN number/service – see § 1.3.1) and not to a specific CUG.

1.2.3 *Qualification on the applicability to telecommunication services*

In general CUG service is defined independently of any basic service, i.e. it applies to an ISDN number. However, the service may be defined in relation to one, or a list of basic services.

1.2.4 *State definitions*

No specifically defined states are required for the CUG service.

1.3 *Operational requirements*

1.3.1 *Provision/withdrawal*

The provision of the CUG service to a new member and also assignment of the various CUG service options (except preferential CUG) individually, require a prior arrangement between the (new) member and the network provider with the consent of the CUG manager for the CUG.

The assignment of a CUG index value to be associated with the CUG and also the assignment of any preferential CUG requires prior arrangement between the (new) member and the network provider only.

The CUG service is provided on a subscription basis. As a network provider option, CUG service can be offered with subscription options. The options can be divided into two groups:

- a) The following options apply per ISDN number. The option values can be assigned individually for each basic service, or set of basic services, available at the ISDN number with CUG service:

| <i>Option</i> | <i>Values</i> |
|---------------------|---|
| 1) Preferential CUG | Default CUG index, or non designated |
| 2) Outgoing access | Allowed permanently, allowed per call, or not allowed |

Note – The “allowed per call” outgoing access option is alternatively known as “outgoing access (explicit)” and the “allowed permanently” outgoing access option is alternatively known as “Outgoing access (implicit)”.

| <i>Option</i> | <i>Values</i> |
|--------------------|-------------------------|
| 3) Incoming access | Allowed, or not allowed |

If for a user with CUG service, a basic service, or set of basic services, is not included in at least one CUG, then:

- preferential CUG must have the “none designated” option value;
- outgoing access will normally have the “allowed permanently” option value if outgoing calls using a basic service or set of basic services are required;
- incoming access will have the “allowed” option value if incoming calls using a basic service or set of basic services are required.

- b) The following option applies per CUG. If the CUG includes more than one basic service, or set of basic services, the value of this option can be assigned individually for each basic service, or set of basic services, including:

| <i>Option</i> | <i>Values</i> |
|---------------------------|---|
| 1) Barring within the CUG | None, incoming calls, or outgoing calls |

If for a particular basic service, or set of basic services, available to an ISDN number, a preferential CUG is nominated, then it shall not be possible to assign the “outgoing calls” barring within the CUG option to that basic service, or set of basic services, for the preferential CUG.

The options assigned to a CUG member are stored in the network.

Note – Whether or not the storage of these options for CUG are centralized or decentralized is beyond the scope of this Recommendation and is defined in the stage 2 of Recommendation of CUG (see Recommendation Q.85.1).

1.3.2 *Requirements on the originating network side*

For correct interactions with other supplementary services, it is necessary for the originating network side to store, for the duration of the call, details of whether a non-CUG, CUG (without outgoing access) or CUG (with outgoing access) call was requested in the information sent to the destination network side. The CUG identity (if any) requested of the destination network side must also be retained.

1.3.3 *Requirements in the network*

This section is not applicable to DSS 1.

1.3.4 Requirements on the terminating network side

For correct interactions with other supplementary services, it is necessary for the destination network side to store, for the duration of the call, details of whether a non-CUG or CUG (with or without outgoing access) call request was passed to the user. The CUG identity (if any) requested must also be retained.

1.4 Coding requirements

1.4.1 Messages

The messages that will be used for the invocation and control of the CUG supplementary service follow:

- a) DISCONNECT (see Note 1);
- b) RELEASE (see Note 1);
- c) RELEASE COMPLETE (see Note 1);
- d) SETUP (see Note 2).

Note 1 – The facility information element may be included in the network-to-user direction in the first call clearing message if the calling user explicitly requests CUG service, if the network cannot allow the call to proceed before returning CUG service acceptance to the calling user. In the user-to-network direction the facility information element may be included in the first call clearing message if the called user cannot allow the call to proceed before returning CUG service acceptance to the network.

Note 2 – In the user-to-network direction the facility information element will be included if the calling user explicitly requests CUG service. In the network-to-user direction facility information element will be included if a CUG call is required.

1.4.2 Operations (ASN.1)

Closed-User-Group-Service-Operations {ccitt recommendation q 955 cug (1)}

DEFINITIONS ::=

BEGIN

EXPORTS CUGCallOperationType ;

IMPORTS OPERATION, ERROR Remote-Operation-Notation {joint-iso-ccitt remote-operations(4) notations(0)}
userNotSubscribed, basicServiceNotProvided FROM General-Error-List
{ccitt recommendation q 950 general-error-list};

CUGCallOperationType ::= -- invoked from calling user to originating
-- network side and from destination network
-- side to user.

OPERATION

ARGUMENT SEQUENCE {
outgoingAccessRequest [1] IMPLICIT BOOLEAN DEFAULT FALSE,
-- if outgoing access is requested then TRUE is set, and
-- if outgoing access is not requested then FALSE is set.
cUGIndex [2] IMPLICIT CUGindex OPTIONAL }
-- in SETUP message

ERRORS {
userNotSubscribed,
basicServiceNotProvided,
invalidOrUnregisteredCUGIndex,
requestedBasicServiceViolatesCUGConstraints,
outgoingCallsBarredWithinCUG,

```

        incomingCallsBarredWithinCUG,
        userNotMemberOfCUG,
        inconsistencyInDesignatedFacilityAndSubscriberClass}
    -- in first clearing message to calling user or network

CUGCallOperation          CUGCallOperationType ::= 2

CUGIndex ::= INTEGER (0..32767)

-- Some networks may specify a max. value of the CUG index from 0 to 9999.

invalidOrUnregisteredCUGIndex          ERROR ::= 16
requestedBasicServiceViolatesCUGConstraints ERROR ::= 17
outgoingCallsBarredWithinCUG          ERROR ::= 18
incomingCallsBarredWithinCUG          ERROR ::= 19
userNotMemberOfCUG                    ERROR ::= 20
inconsistencyInDesignatedFacilityAndSubscriberClass ERROR ::= 21

END -- of closed user group service operations

```

1.5 *Signalling requirements*

1.5.1 *Activation/deactivation/registration*

No signalling procedure is necessary for activation, deactivation and registration.

1.5.2 *Invocation and operation*

The CUG service is invoked by:

- a call originating from a user that has CUG service. The user can explicitly request CUG service, but in the absence of an explicit request the CUG service default procedures are automatically applied;
- a call terminating at a user that has CUG service.

1.5.2.1 *Normal operation*

1.5.2.1.1 *Actions at the originating local exchange*

1.5.2.1.1.1 *Call originating from a user with CUG service*

1.5.2.1.1.1.1 *Explicit request of CUG service*

The calling user can explicitly request the CUG service by including in the outgoing SETUP message a facility information element containing a CUG call invoke component.

To indicate outgoing access the user shall set the value of the Outgoing Access Request parameter to TRUE.

The network performs internal checks appropriate to the originating network side based on the contents of the invoke component and the CUG attributes of the calling user. The outcome of these checks are defined in Table 1-1/Q.955 (including Notes).

Note – The network might respond to the SETUP message with a SETUP ACKNOWLEDGE or CALL PROCEEDING message or the call might be cleared for some non-CUG service related reasons before the checks are completed.

If the result of the checks relevant to the originating network side allow the call to proceed, then the network performs further internal checks based on the CUG attributes (if any) of the called user. The outcome of these checks are defined in Table 1-2/Q.955.

If the call is successfully offered to the called user, an ALERTING or CONNECT message according to basic call control, shall be returned to the calling user.

1.5.2.1.1.1.2 *Implicit request of CUG service*

The calling user with CUG service can request the CUG service without including an invoke component in the outgoing setup message (e.g. to make use of the preferential CUG facility). In this case the procedures of § 1.5.2.1.1.1.1 apply with the following exception:

- the network performs internal checks appropriate to the originating network side only based on the CUG attributes of the calling user.

1.5.2.1.1.2 *Call originating from a user without CUG service*

It is possible for a user without CUG service to make a call to a user with CUG service. If such a calling user does not include a CUG call invoke component in the outgoing SETUP message, Table 1-1/Q.955 shall apply.

The network then performs further internal checks based on the CUG attributes (if any) of the called user. The outcome of these checks are defined in Table 1-2/Q.955.

If the call is successfully offered to the called user, no return result component shall be returned to the calling user.

1.5.2.1.2 *Actions at the transit exchange*

This section is not applicable to DSS 1.

1.5.2.1.3 *Actions at the destination local exchange*

If the internal checks defined in Table 1-2/Q.955 result in a requirement for a CUG call (with or without outgoing access request) to the called user, then the incoming SETUP message shall include a facility information element containing a CUG call invoke component.

If the call is successfully offered to the called user, no return result component shall be expected by the network.

1.5.2.2 *Exceptional procedures*

1.5.2.2.1 *Actions at the originating local exchange*

1.5.2.2.1.1 *Call originating from a user with CUG service*

1.5.2.2.1.1.1 *Explicit request of CUG service*

If the network cannot allow the call to proceed for a CUG service related reason as a result of the checks relevant to either the originating or the destination network side, then the network shall fail the call attempt and include in the first clearing message returned to the calling user a facility information element containing a return error component with the appropriate indication as defined by Tables 1-1/Q.955 and 1-2/Q.955 (including Notes).

The Q.931 cause in the clearing message conveying the return error component will be No. 29 “facility rejected”.

If the call attempt fails for a non-CUG service related reason, then a facility information element containing a return error component indicating “basic service not provided” should be included in the first clearing message returned to the calling user. The Q.931 cause used will be determined by the event causing the failure. However, even if a facility information element containing a return error component will not be included in the first clearing message to the calling user, the terminal shall continue normal clearing and abandon the operation.

The possibility of “simultaneous” failure for CUG and non-CUG service related reasons is not precluded. In this case the return error component will contain an indication as defined by Tables 1-1/Q.955 and 1-2/Q.955, but the Q.931 cause will be determined by the non-CUG service event causing call failure.

TABLE 1-1/Q.955

CUG check at the originating network side

This table is used to determine the type of call request sent to the destination network side and the type of rejection indications returned to the calling user.

Note — The type of call request derived from this table determines the linkage to Table 1-2/Q.955

| CUG attributes of calling user for requested basic service | | CUG information received from calling user in SETUP | | | | |
|--|---------|---|---|---|---|---|
| | | CUG call invoke received | | | | No CUG call invoke received |
| | | OA not requested CUG index | OA requested CUG index | OA not requested no CUG index | OA requested no CUG index | |
| O/access not allowed | Not OCB | CUG call IC = spec CUG (Note 1) | CUG call IC = spec CUG (Note 1) | Rejected RE-VAL = No. 21 (Note 5) | Rejected RE-VAL = No. 21 (Note 5) | Rejected Rec. Q.931 CAUSE = No. 29 (Note 5) |
| | OCB | Rejected RE-VAL = No. 18 | Rejected RE-VAL = No. 18 | | | |
| O/access per call | Not OCB | CUG call IC = spec CUG (Note 1) | CUG + OA IC = spec CUG (Note 2) | Rejected RE-VAL = No. 21 (Note 5) | Non-CUG call (Note 5) | Rejected Rec. Q.931 CAUSE = No. 29 (Note 5) |
| | OCB | Rejected RE-VAL = No. 18 | Non-CUG call | | | |
| O/access permanent | Not OCB | CUG + OA IC = spec CUG (Note 1) | CUG + OA IC = spec CUG (Note 1) | Non-CUG call (Note 5) | Non-CUG call (Note 5) | Non-CUG call (Note 5) |
| | OCB | Non-CUG call | Non-CUG call | | | |
| Preferential CUG nominated O/access not allowed | Not OCB | CUG call IC = spec CUG (Note 3) | CUG call IC = spec CUG (Note 3) | CUG call IC = preferential CUG | Rejected RE-VAL = No. 21 | CUG call IC = preferential CUG |
| | OCB | Rejected RE-VAL = No. 18 (Note 4) | Rejected RE-VAL = No. 18 (Note 4) | Combination barred (Note 6) | Combination barred (Note 6) | Combination barred (Note 6) |
| Preferential CUG nominated O/access per call | Not OCB | CUG call IC = spec CUG (Note 3) | CUG + OA IC = spec CUG (Note 3) | CUG call IC = preferential CUG | Non-CUG call | CUG call IC = preferential CUG |
| | OCB | Rejected RE-VAL = No. 18 (Note 4) | Non-CUG call (Note 4) | Combination barred (Note 6) | Combination barred (Note 6) | Combination barred (Note 6) |
| Preferential CUG nominated O/access permanent | Not OCB | CUG + OA IC = spec CUG (Note 3) | CUG + OA IC = spec CUG (Note 3) | (Note 8) | CUG + OA call IC = preferential CUG | (Note 8) |
| | OCB | Non-CUG call (Note 4) | Non-CUG call (Note 4) | Combination barred (Note 6) | Combination barred (Note 6) | Combination barred (Note 6) |
| Not a CUG user | | Rejected RE-VAL = No. 0 | Rejected RE-VAL = No. 0 | Rejected RE-VAL = No. 0 | Rejected RE-VAL = No. 0 | Non-CUG call (Note 7) |

OA Outgoing access
 OCB Outgoing call barred
 IC CUG interlock code
 RE Return error
 RE-VAL Return error value

| | |
|-------------------------|---|
| RE-VAL No. 0 | User not subscribed |
| RE-VAL No. 16 | InvalidOrUnregisteredCUGIndex |
| RE-VAL No. 17 | Requested basic service violates CUG constraints |
| RE-VAL No. 18 | Outgoing calls barred within CUG |
| RE-VAL No. 21 | Inconsistency in designated facility and subscriber class |
| Rec. Q.931 CAUSE No. 29 | Facility rejected |

Note 1 — Assumes match between CUG index and IC exists for the requested basic service. If no match exists then:

- if the CUG index exists but is not appropriate to the requested basic service the call is rejected with RE-VAL = No. 17;
- Note that this includes the case when the requested basic service is not included in any CUG;
- if the CUG index does not exist the call is rejected with RE-VAL = No. 16.

Note 2 — Assumes match between CUG index and IC exists for the requested basic service. If no match exists then:

- if the CUG index exists but is not appropriate to the requested basic service the call proceeds as a non-CUG call.

Note that this includes the case when the requested basic service is not included in any CUG;

- if the CUG index does not exist the call is rejected with RE-VAL = No. 16.

Note 3 — Assumes match between CUG index and IC exists for the requested basic service. If no match exists then:

- if the CUG index exists but is not appropriate to the requested basic service the call is rejected with RE-VAL = No. 17;
- if the CUG index does not exist the call is rejected with RE-VAL = No. 16.

Note 4 — If the CUG index identifies the preferential CUG then this combination is barred in the options data, i.e. the preferential CUG cannot be assigned the “outgoing calls” barring within the CUG option.

Note 5 — This includes the case when the requested basic service is not included in any CUG.

Note 6 — This combination is barred in the options data, i.e. the preferential CUG cannot be assigned the “outgoing calls” barring within the CUG option.

Note 7 — This represents the normal case of a user without CUG service making a non-CUG call.

Note 8 — Both “preferential CUG” and “allowed permanently” outgoing access options imply that either of them can be requested without including an invoke component in the outgoing SETUP message. When a user subscribes to both options, a network does not know which option the user is invoking in the outgoing SETUP message.

Three ways of operating are recommended:

- 1) the user has to indicate if a call is intended to be an outgoing access call. If no information (CUG request or outgoing call request) is given, the preferential CUG is assumed;
- 2) the combination of the options is not allowed, i.e. a user cannot have both options allocated at the same time;
- 3) the caller may make a call and the network will route the call with the preferential CUG and an outgoing access request. The call will therefore be connected if the called number is a member of the preferential CUG or is a member of a different CUG and has incoming access, or is a non-CUG user.

In the case of option 1) the type of call request sent to the destination network side is “CUG (IC = pref.)”.

In the case of option 2) the combination of the options is not allowed.

In the case of option 3) the type of call request sent to the destination network side is “CUG + OA (IC = pref.)”.

The choice from the above cases is a national option.

TABLE 1-2/Q.955

CUG checks at the destination network side

This table can be used to determine the type of call request sent to the destination user and the type of rejection indications returned to the calling user.

| Type of CUG indication from the network | M or NM | CUG attributes of called user for requested basic service | | | | Not a CUG user |
|---|---------|---|--------------------------|-----------------------------------|--------------------------|--------------------------|
| | | I/access not allowed | | Incoming access allowed | | |
| | | Not ICB | ICB | Not ICB | ICB | |
| CUG call with no O/access indication | M | CUG call | Rejected RE-VAL = No. 19 | CUG call | Rejected RE-VAL = No. 19 | Rejected RE-VAL = No. 20 |
| | NM | Rejected RE-VAL = No. 20 (Note 1) | | Rejected RE-VAL = No. 20 (Note 1) | | |
| CUG call with O/access indication | M | CUG call with OA request | Rejected RE-VAL = No. 19 | CUG call with OA request | Non-CUG call | Non-CUG call |
| | NM | Rejected RE-VAL = No. 20 (Note 1) | | Non-CUG call (Note 2) | | |
| Non-CUG call | — | Rejected RE-VAL = No. 20 (Note 2) | | Non-CUG call (Note 2) | | Non-CUG call (Note 3) |

ICB Incoming call barred

M Match between IC and CUG index exists for the requested basic service

NM No match between IC and CUG index exists for the requested basic service

IC CUG interlock code

RE "Return error" component returned to calling user

RE-VAL "Return error" value

RE-VAL No. 17 Requested basic service violates CUG constraints

RE-VAL No. 19 Incoming calls barred within CUG

RE-VAL No. 20 User not member of CUG

Key to cross points in table:

CUG call Invoke component in SETUP message identifies CUG index but does not request outgoing access

CUG call with OA request Invoke component in SETUP message identifies CUG index and requests outgoing access

Non-CUG call No invoke component in SETUP message

Note 1 — Assumes that the CUG match fails because the IC does not exist for the called user. If the IC exists but is not appropriate to the requested basic service, then the call is rejected with RE-VAL = No. 17.

Note that this includes the case when the requested basic service is not included in any CUG.

Note 2 — This includes the case when the requested basic service is not included in any CUG.

Note 3 — This represents the normal case of a user without CUG service receiving a non-CUG call.

1.5.2.2.1.1.2 *Implicit request of CUG service*

If the calling user with CUG service does not include an invoke component in the outgoing SETUP message (e.g. to make use of the preferential CUG facility) the procedures of § 1.5.2.2.1.1.1 apply with the following exceptions:

- 1) if either the originating or destination network side cannot allow the call to proceed for a CUG service related reason, the network shall initiate call clearing using the following Q.931 causes:
 - No. 87 “user not a member of CUG” if the corresponding return error value would be No. 20 “user not a member of CUG” using the explicit request procedures;
 - No. 29 “facility rejected” in the case of all other CUG service related reasons,
- 2) when a call fails for a purely non-CUG service related reason, then no indication of “basic service not provided” is provided to the calling user.

1.5.2.2.1.2 *Call originating from a user without CUG service*

If the calling user includes in the outgoing SETUP message a facility information element containing a CUG call invoke component, and the network can recognize that the calling user is requesting CUG service, then it shall include in the first CLEARING message returned to the calling user a facility information element containing a return error component with the appropriate indication as defined by Table 1-1/Q.955, i.e. “user not subscribed”.

If the calling user does not include a facility information element, and the network cannot allow the call to proceed as a result of the checks relevant to the destination network side, then the network shall fail the call attempt and initiate clearing with Q.931 cause No. 87 “user not a member of CUG”. No CUG service related indication shall be conveyed to the calling user.

If the call attempt fails for a non-CUG service related reason, then no CUG service related procedures apply.

1.5.2.2.2 *Actions at the transit exchange*

This section is not applicable to DSS 1.

1.5.2.2.3 *Actions at the destination local exchange*

If after transmitting the incoming SETUP message and before receiving an ALERTING message, the call attempt fails for a CUG or non-CUG service related reason, then the network expects a return error component with the appropriate indication in the first clearing message received from the called user. If the call attempt fails for a CUG service related reason, the Q.931 cause in the clearing message conveying the return error component will normally be No. 29 “facility rejected”. The indication in the return error component shall be sent back to the calling user. Absence of the return error component shall be regarded by the destination network side as a failure for non-CUG service related reasons.

In the case of a SETUP message sent via the broadcast data link, the network may, as a network option, retain the return error component along with the Q.931 cause retained according to § 5.2.5.3 of Recommendation Q.931. If there are multiple clearing messages containing return error components, the indication in the return error component contained in the first clearing message will be sent back to the calling user. If any of the clearing messages with the highest Q.931 causes do not contain return error components and other clearing messages with Q.931 causes of lower priority do contain return error components, no indication in these return error components shall be sent back to the calling user.

1.6 *Interaction with other supplementary services*

1.6.1 *Call Waiting*

No interaction.

1.6.2 *Call Transfer*

No applicable interaction at this time.

1.6.3 *Connected Line Identification Presentation*

No interaction.

1.6.4 *Connected Line Identification Restriction*

No interaction.

1.6.5 *Calling Line Identification Presentation*

No interaction.

1.6.6 *Calling Line Identification Restriction*

No interaction.

1.6.7 *Closed User Group*

Not relevant.

1.6.8 *Conference Calling*

No applicable interaction at this time.

1.6.9 *Direct-Dialling-in*

When the user has also subscribed to the DDI supplementary service, the CUG supplementary service is provided on the basis of that part of the ISDN number which the network can recognize or with the default number valid for that access. However CUG membership shall not be available on a per DDI number basis, but instead shall be on the basis of the entire range of DDI members applicable at an access or group of accesses.

1.6.10 *Call diversion (call forwarding) services*

1.6.10.1 *Call Forwarding Busy*

No interaction.

1.6.10.2 *Call Forwarding No Reply*

No interaction.

1.6.10.3 *Call Forwarding Unconditional*

No interaction.

1.6.10.4 *Call Deflection*

No interaction.

1.6.11 *Line Hunting*

Interaction is specified in Recommendation Q.952, § 6.

1.6.12 *Three-Party-Service*

Interaction is specified in Recommendation Q.954, § 2.

1.6.13 *User-to-User Signalling*

1.6.13.1 *Service 1*

No interaction

1.6.13.2 *Service 2*

No interaction

1.6.13.3 *Service 3*

No interaction

1.6.14 *Multiple Subscriber Number*

It shall be possible to provide separate CUG services for each ISDN number both at the calling and called sides.

If the calling terminal does not identify its MSN, then the CUG attributes assigned to the default number shall be applied by the originating network side.

It is the CUG manager's responsibility to ensure that a passive bus does not compromise CUG integrity.

1.6.15 *Call Hold*

No interaction.

1.6.16 *Advice of Charge*

No interaction.

1.6.17 *Sub-addressing*

No interaction.

1.6.18 *Terminal Portability*

No interaction.

1.6.19 *Completion of Calls to Busy Subscriber*

No applicable interaction at this time.

1.6.20 *Malicious Call Identification*

No applicable interaction at this time.

1.7 *Interaction with other networks*

1.7.1 *Interaction with public network*

Where a CCITT Signalling System No. 7 link exists between two networks, bilateral agreement is required to allow a CUG interlock code to be unique across both networks.

Note that part of the CUG interlock code already identifies the allocating country.

When a CCITT Signalling System No. 7 network interworks with a network not supporting CUG service (e.g. an analogue network), the gateway allows non-CUG calls and CUG calls requesting outgoing access to proceed as normal calls. In the latter case the CUG interlock code is discarded and there is no CUG specific notification returned to the originating network side.

In the case of CUG calls (without outgoing access request) the gateway rejects the call request. Within the return error component returned to the calling user, the indication shall be "user not member of CUG" and the Q.931 cause will normally be No. 29 "facility rejected".

1.7.2 *Interaction with private ISDN*

When a public network CUG interacts with a private network CUG by way of an access, it is possible, by mapping between the two CUG domains in the gateway (e.g. PBX), to arrange for CUG users to perceive the concatenated CUG domains as a single CUG.

Under these circumstances the access must behave as an internodal link for CUG purposes.

If the private network with a private network CUG domain is the originating network, a public CUG index should be indicated in a SETUP message whenever CUG service is requested so that the private network can receive proper indications of public CUG failures or destination private CUG failures.

Therefore when the private network anticipates interaction with a public CUG domain at the originating side, it shall use only the explicit request of CUG service.

If the private network is the destination network, no special procedures are required.

1.8 *Signalling flows*

The following examples show only the messages which convey CUG information and their CUG related contents. Otherwise, basic call control applies.

1.9 *Parameter value (timers)*

1.10 *Dynamic description (SDLs)*

The SDL description is shown in Figures 1-5/Q.955 and 1-6/Q.955.

Figures 1-5/Q.955 and 1-6/Q.955 provide the SDL description of the CUG process at the originating and destination network sides respectively.

The CUG process is modelled as an extension of the call control process. Information can pass between the call control and CUG processes by means of primitives.

The call control process communicates certain call control events and parameters to the CUG process and then waits for instructions to proceed from the CUG process. The primitives from the CUG process fall into two categories:

- a) *Continue*: The continue primitive prompts the call control process to proceed but does not change the course of call control in establishing or clearing the call attempt. It may provide additional instructions from the CUG process to call control, e.g.:
 - *normal*: no additional instructions to call control;
 - apply checks – call control required to perform the appropriate CUG checks and then proceed (note that the stage 2 description functional entities FE3 “outgoing CUG control” and FE5 “incoming CUG control” are not modelled as part of the stage 3 description “CUG process”);
 - RE value – call control required to include a *CUG call* return error component with the indicated value in the first clearing message to the calling user;
- b) *Clear call*: The clear call primitive causes call control to move from call establishment to appropriate call clearing procedures using the additional information provided by the CUG process.

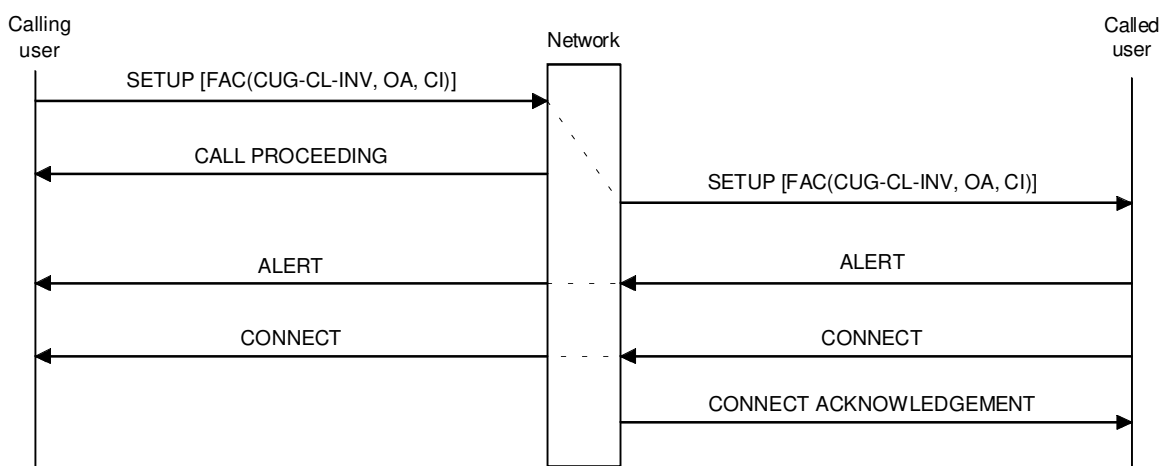

T1124750-90

FIGURE 1-1/Q.955

Call passes both originating and destination network checks and is successful

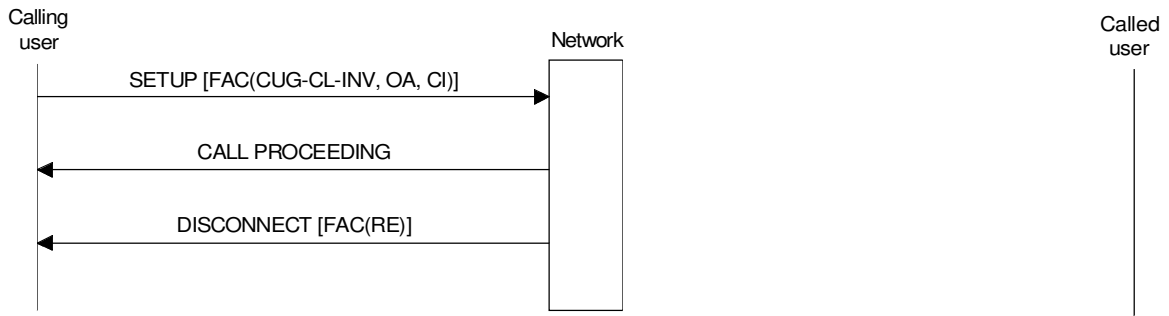

T1124760-90

FIGURE 1-2/Q.955

Call fails destination network side checks

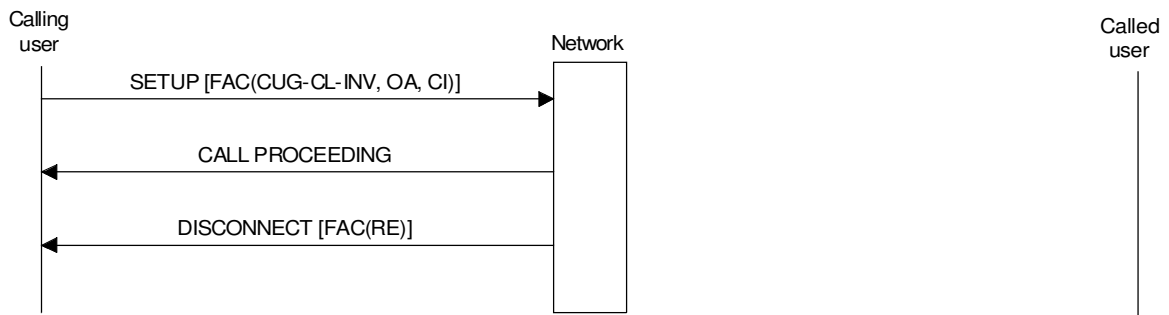

T1124770-90

FIGURE 1-3/Q.955

Call fails origination network side checks

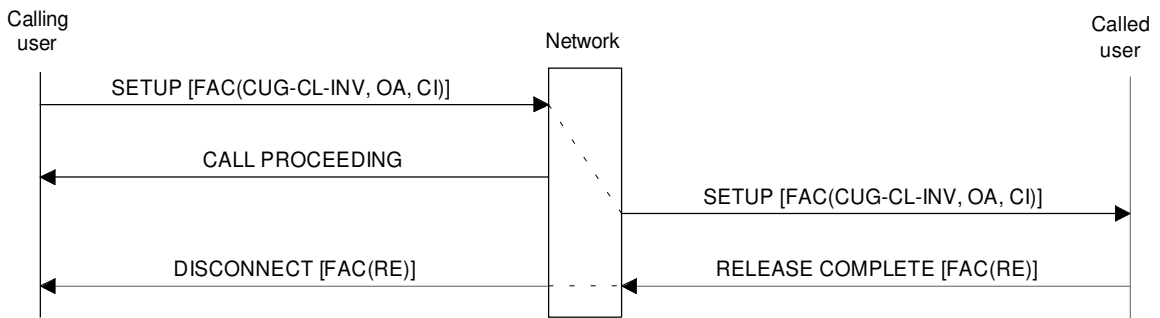
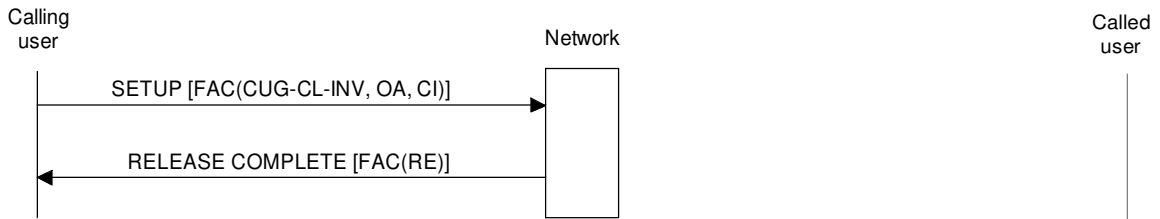

FAC Facility information element
 CUG-CL-INV CUG call invoke
 RE Return error
 CI CUG index
 OA Outgoing access

T1124780-90

Note – Point-to-point configuration is assumed for the called user.

FIGURE 1-4/Q.955

Call passes both originating and destination network checks and fails at the called user side

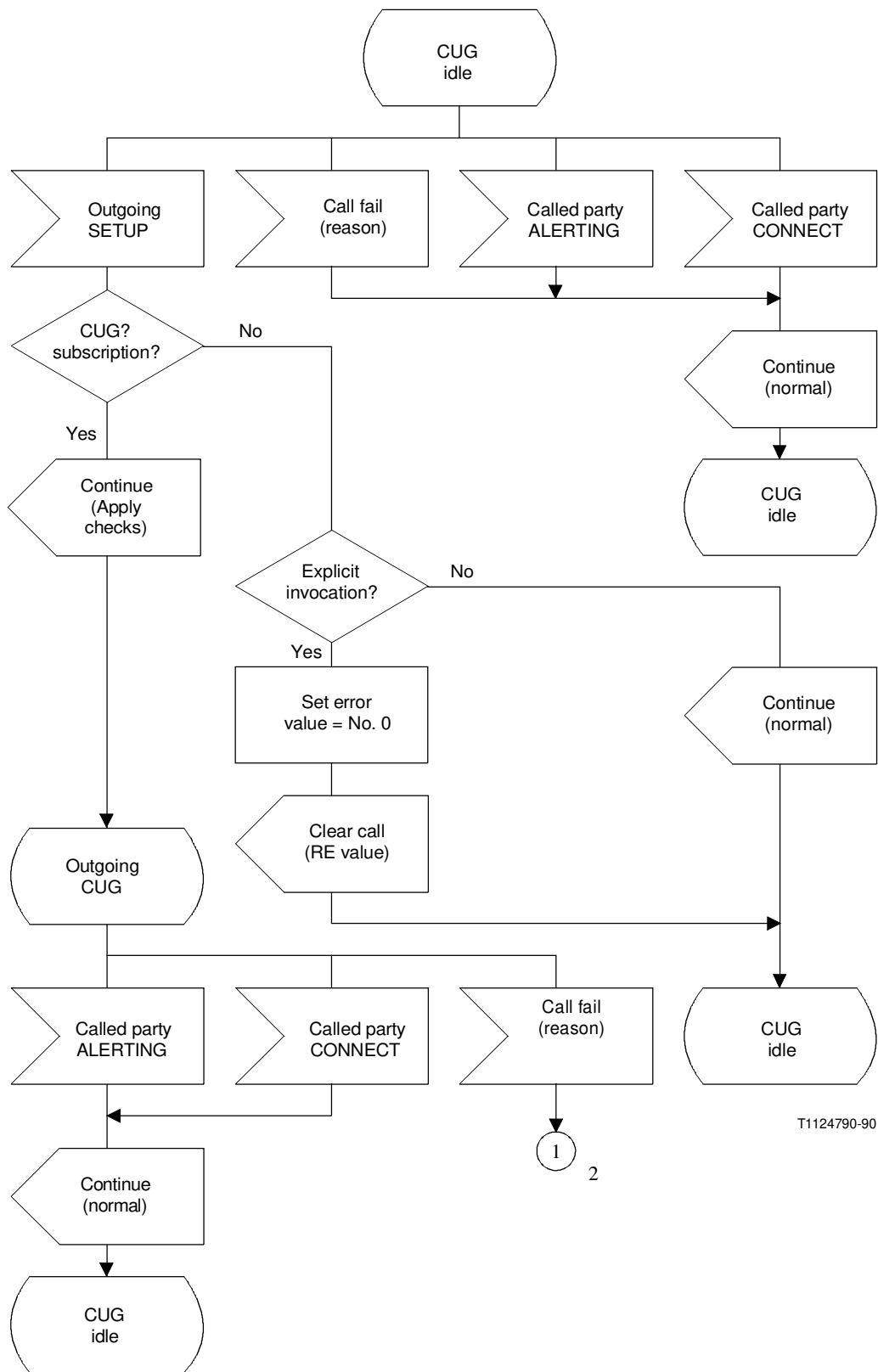

T1124790-90

FIGURE 1-5/Q.955 (sheet 1 of 2)
CUG process – Outgoing call (network side)

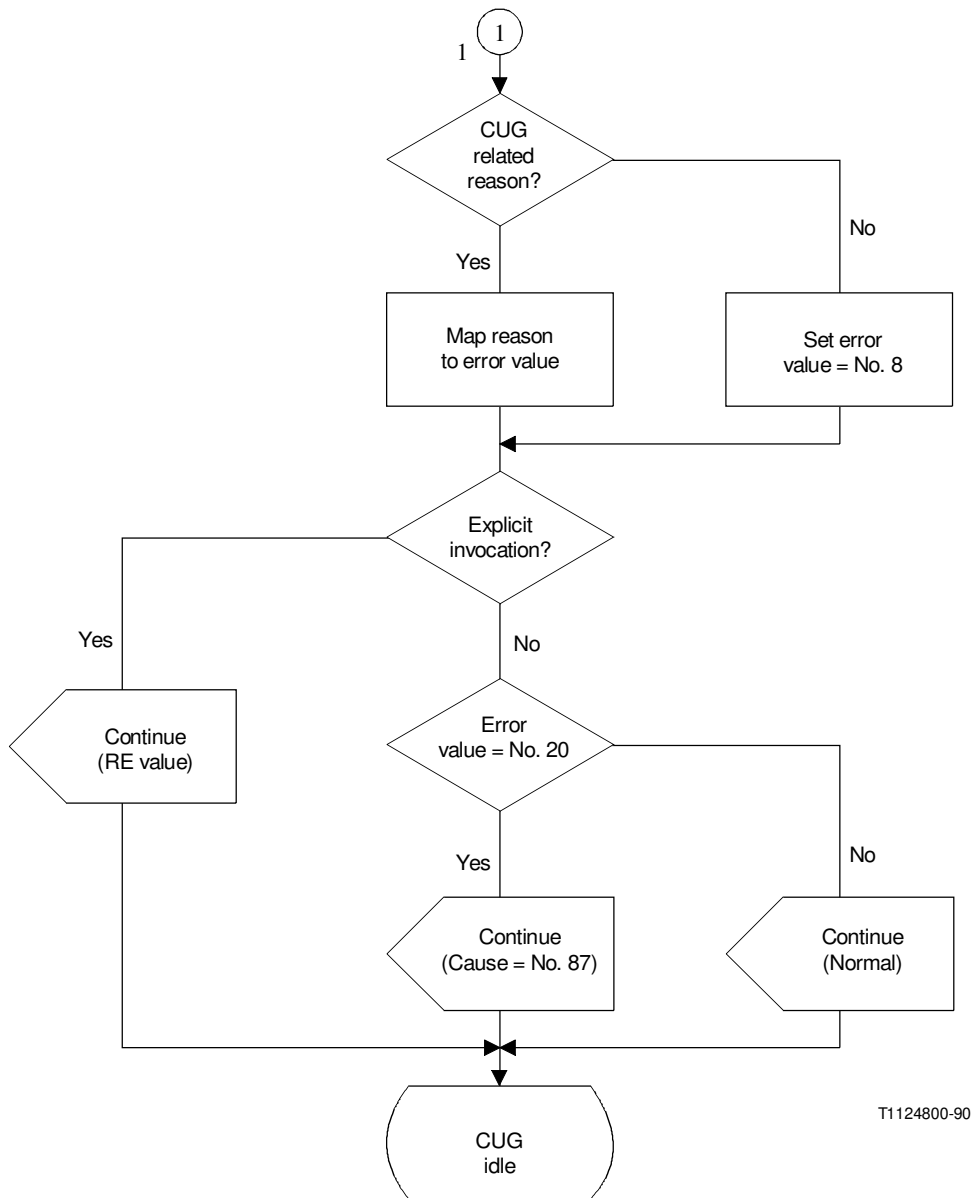

T1124800-90

FIGURE 1-5/Q.955 (sheet 2 of 2)

CUG process – Outgoing call (network side)

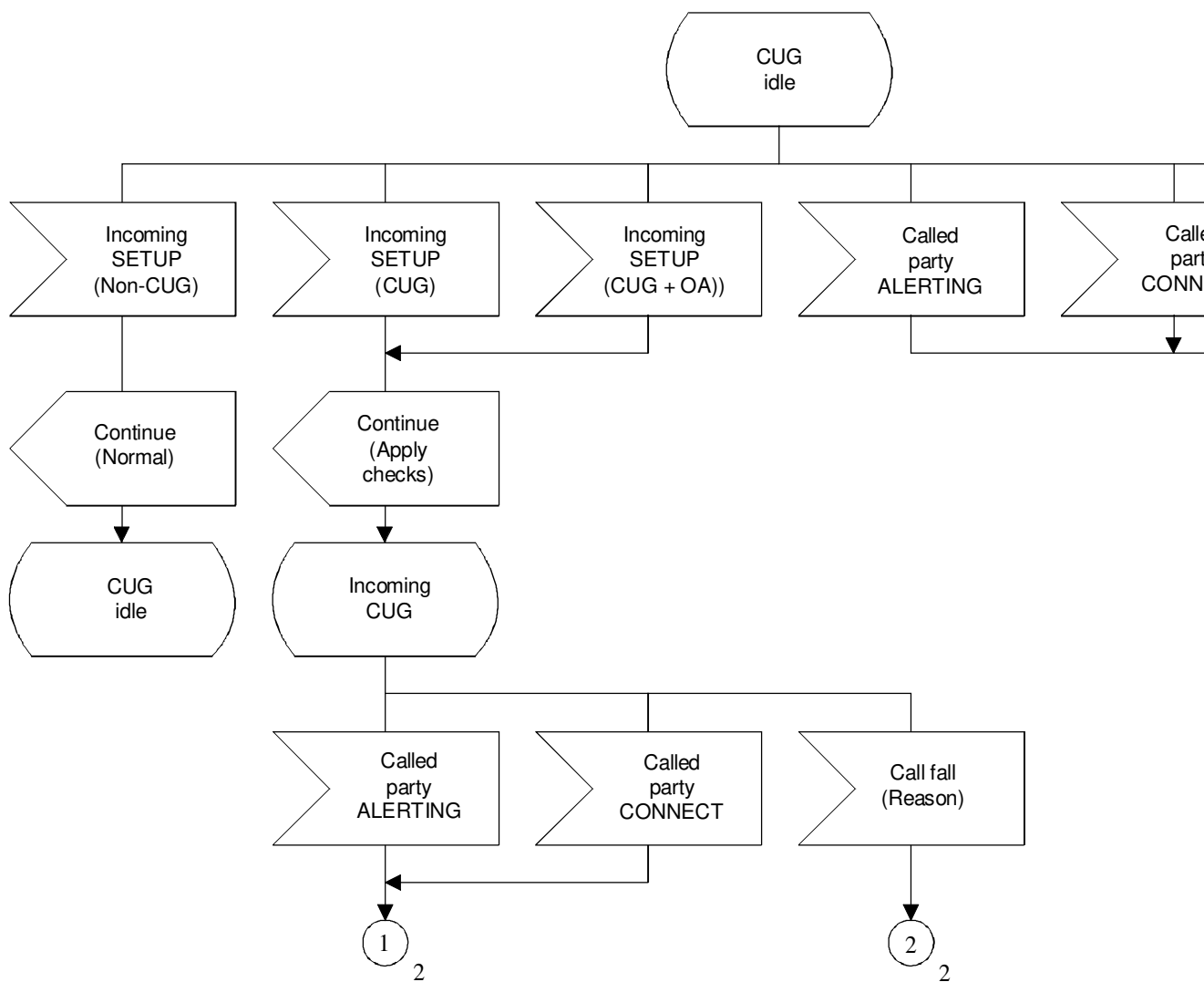

FIGURE 1-6/Q.955 (sheet 1 of 2)

CUG process – Incoming call (network side)

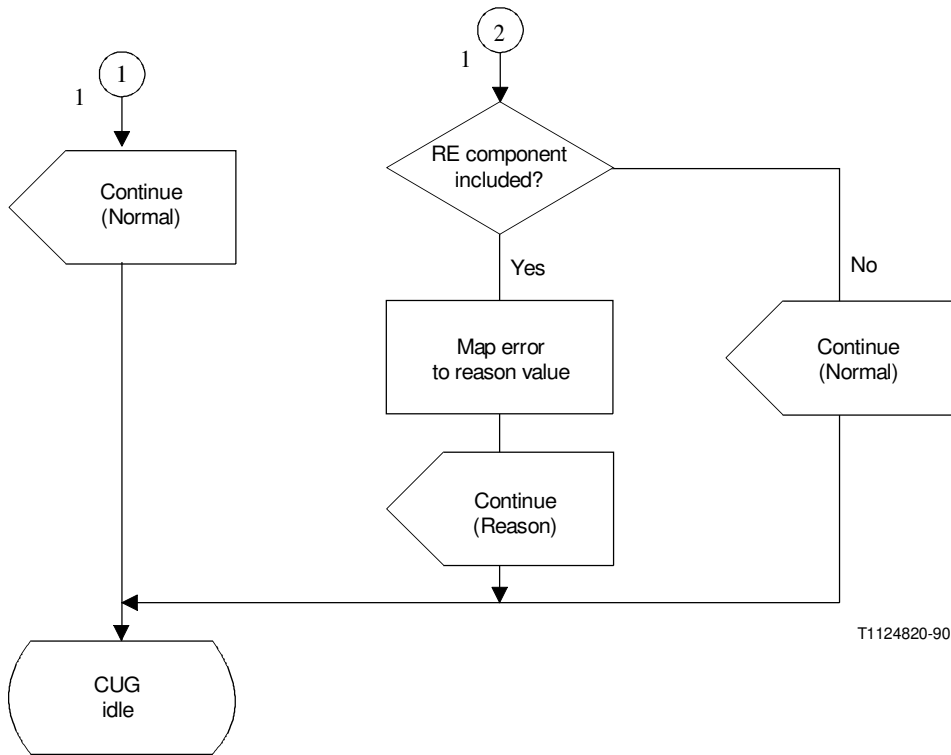

FIGURE 1-6/Q.955 (sheet 2 of 2)

CUG process – Incoming call (network side)

ANNEX A

(to § 1 of Recommendation Q.955)

Diagrammatic description of coding requirements

This annex gives examples on the detailed coding of the following components:

- invoke component;
- Return error component.

Note – The formal description of this component is defined in § 1.4 of this Recommendation which takes precedence over this annex in case of discrepancy. The structure and encoding is only one possible version and the full range of legal encodings is given in the formal definition in § 1.4.

A.1.1 *Invoke component*

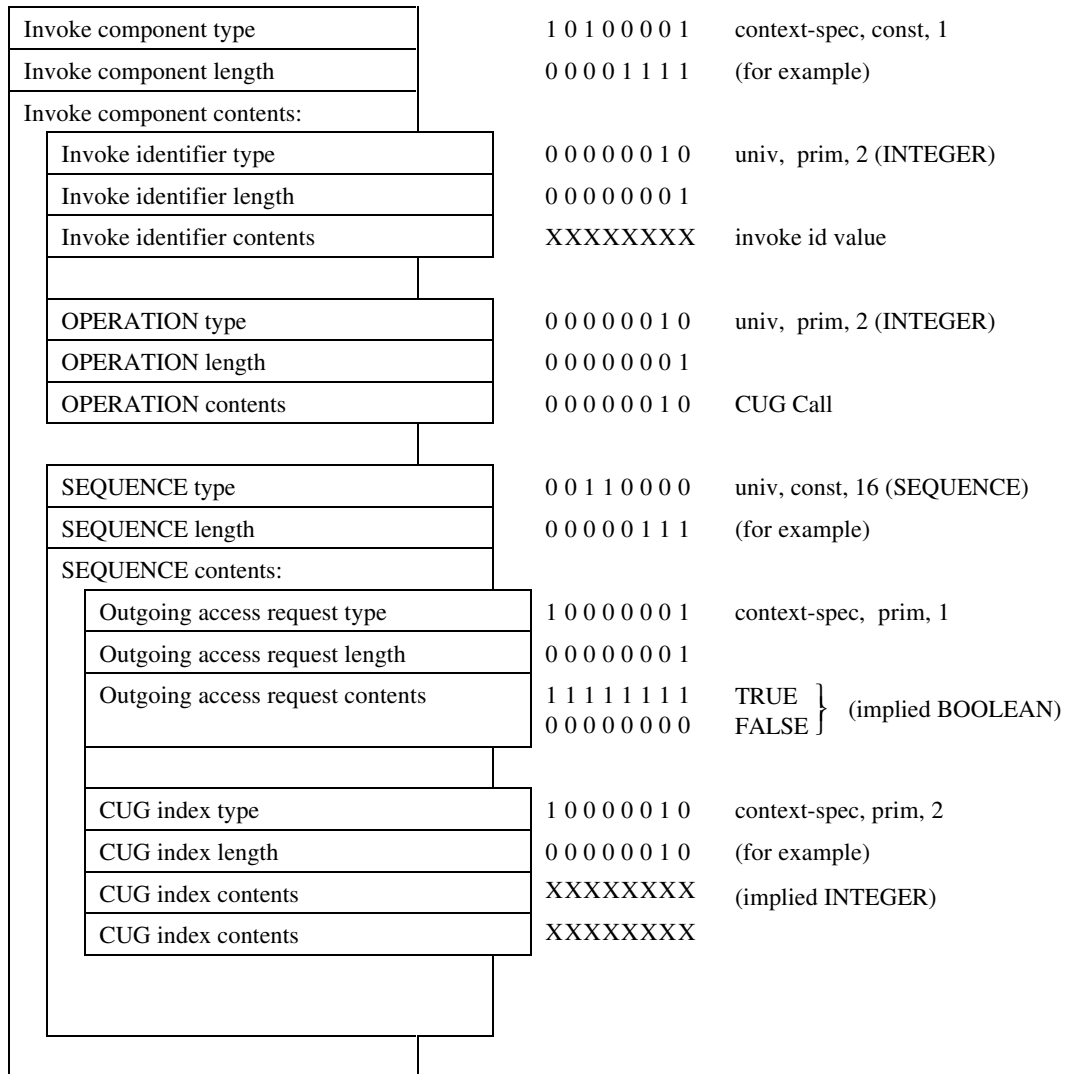

A.1.2 *Return error component*

| | | |
|-------------------------------|------------------------------------|--|
| Return error component type | 1 0 1 0 0 0 1 1 | context-spec, const, 3 |
| Return error component length | 0 0 0 0 0 1 1 0 | |
| Return error component cont: | | |
| Invoke identifier type | 0 0 0 0 0 0 1 0 | univ, prim, 2 (INTEGER) |
| Invoke identifier length | 0 0 0 0 0 0 0 1 | |
| Invoke identifier contents | XXXXXXXX | invoke id value |
| Error type | 0 0 0 0 0 0 1 0 | univ, prim, 2 (INTEGER) |
| Error length | 0 0 0 0 0 0 0 1 | |
| Error contents | 0 0 0 0 0 0 0 0 0 0 0 0 1 0 0 0 | (0) User not subscribed (8) Basic service not provided |
| | 0 0 0 1 0 0 0 0 | (16) Invalid or unregistered CUG index |
| | 0 0 0 1 0 0 0 1 | (17) Requested basic service violates CUG constraints |
| | 0 0 0 1 0 0 1 0 | (18) Outgoing calls barred within CUG |
| | 0 0 0 0 0 0 1 1 | (19) Incoming calls barred within CUG |
| | 0 0 0 1 0 1 0 0 | (20) User not member of CUG |
| | 0 0 0 1 0 1 0 1 | (21) Inconsistency in designated facility and subscriber class |
| | All other values are reserved. | |