



INTERNATIONAL TELECOMMUNICATION UNION

CCITT

Q.84

THE INTERNATIONAL
TELEGRAPH AND TELEPHONE
CONSULTATIVE COMMITTEE

**FUNCTIONS AND INFORMATION FLOWS
FOR SERVICES IN THE ISDN**

**STAGE 2 DESCRIPTION FOR MULTIPARTY
SUPPLEMENTARY SERVICES**

SECTION 2 – THREE-PARTY SERVICE

Recommendation Q.84



Geneva, 1992

FOREWORD

The CCITT (the International Telegraph and Telephone Consultative Committee) is a permanent organ of the International Telecommunication Union (ITU). CCITT is responsible for studying technical, operating and tariff questions and issuing Recommendations on them with a view to standardizing telecommunications on a worldwide basis.

The Plenary Assembly of CCITT which meets every four years, establishes the topics for study and approves Recommendations prepared by its Study Groups. The approval of Recommendations by the members of CCITT between Plenary Assemblies is covered by the procedure laid down in CCITT Resolution No. 2 (Melbourne, 1988).

Recommendation Q.84 was prepared by Study Group XI and was approved under the Resolution No. 2 procedure on the 4th of February 1992.

CCITT NOTE

In this Recommendation, the expression "Administration" is used for conciseness to indicate both a telecommunication Administration and a recognized private operating agency.

© ITU 1992

All rights reserved. No part of this publication may be reproduced or utilized in any form or by any means, electronic or mechanical, including photocopying and microfilm, without permission in writing from the ITU.

Recommendation Q.84

STAGE 2 DESCRIPTION FOR MULTIPARTY SUPPLEMENTARY SERVICES

2 Three-Party Service (3PTY)

2.1 *Scope*

This Recommendation defines the stage 2 of the Three-Party supplementary service. Stage 2 identifies the functional capabilities and the information flows needed to support the service as described in stage 1. The stage 2 description also identifies user operations not directly associated with a call (see Recommendation I.130 [1]).

This Recommendation is specified according to the methodology specified in Recommendation Q.65 [2].

In addition, this Recommendation does not specify the requirements where the service is provided to the user via a private ISDN. This Recommendation does not specify the requirements for the allocation of defined functional entities within a private ISDN, it does however, define which functional entities may be allocated to a private ISDN.

This Recommendation does not specify the additional requirements where the service is provided to the user via a telecommunications network that is not an ISDN.

The Three-Party supplementary service enables a user who is involved in, at least, two calls (on active call and at least on call on hold) to join the two calls together into a 3-way conversation, i.e. a simultaneous communication between the served user and two other parties.

This supplementary service is not applicable to non-voice services.

This Recommendation is applicable to the stage 3 standards for the integrated services digital network.

2.2 *Normative references*

This Recommendation incorporates by dated or undated reference, provisions from other publications. These normative references are cited at the appropriate place in the text and the publications are listed hereafter. For dated references subsequent amendments to, or revisions of, any of these publications apply to this Recommendation only when incorporated in it by amendment or revision. For undated references the latest edition of the publication referred to applies.

- [1] CCITT Rec. I.130 – *Method for the characterization of telecommunication services supported by an ISDN and network capabilities of an ISDN*, 1988.
- [2] CCITT Rec. Q.65 – *Stage 2 of the method for the characterization of services supported by an ISDN*, 1988.
- [3] CCITT Rec. I.112 – *Vocabulary of terms for ISDNs*, 1988.
- [4] CCITT Rec. Q.9 – *Vocabulary of switching and signalling terms*, 1988.
- [5] CCITT Rec. Q.71¹⁾ – *ISDN 64 kbit/s circuit mode switched bearer service*, 1993.
- [6] CCITT Rec. Q.950 – *Supplementary Services protocols – Structure and general principles*.

2.3 *Definitions*

For the purpose of this Recommendation, the following definitions apply:

¹⁾ Recommendation Q.71 will be submitted for approval at the CCITT Plenary Assembly in March, 1993.

Integrated services digital network (ISDN)

See Recommendation I.112 [3], § 2.3, definition 308.

Service; telecommunications service

See Recommendation I.112 [3], § 2.2, definition 201.

Basic access

See Recommendation Q.9 [4], § 1, definition 1551.

2.4 *Symbols and abbreviations*

CC	Call control
CCA	Call control agent
CUG	Closed User Group
FE	Functional entity
FEA	Functional entity action
ISDN	Integrated services digital network
LE	Local exchange
PNX	Private network exchange
SDL	Specification and description language
TE	Terminal equipment
3PTY	Three-Party Service

2.5 *Description*

Not applicable.

2.6 *Derivation of the functional model*

2.6.1 *Functional model description*

See Figure 2-1/Q.84.

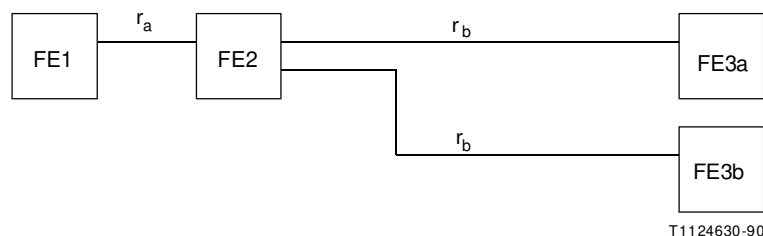

FIGURE 2-1/Q.84

Functional model

The functional entities required for the Three-Party supplementary service above those of the basic call are:

- FE1 Served user's service agent
- FE2 3PTY service control entity
- FE3 Remote user's service agent

2.6.2 *Description of the functional entities*

In addition to the functions required for basic services and hold services, the following functions are identified to be necessary for providing the Three-Party Service:

- bridge;
- split.

2.6.2.1 *Functionality of FE1 for the Three-Party Service*

FE1 provides functional extensions to the related CCA.

The main functions of FE1 are:

- to translate the implicit user service request into explicit information flows to the FE2;
- to provide the correlation between the two calls to be handled;
- to access the service providing capabilities of FE2 by way of functional service request;
- to receive functional indications relating to the call from FE2 and relay them to the “user” of the call;
- to translate the user service request into explicit information flows to FE2 for the establishment and control of a 3-way conversation. This includes:
 - requesting a 3-way conversation;
 - split a 3-way conversation.

2.6.2.2 *Functionality of FE2 for the Three-Party Service*

The main functions of FE2 are:

- check and validate subscription options and service resources (e.g., bridge resources);
- check and validate interactions with basic and supplementary services;
- recognize functional service requests from FE1 and respond to functional service requests from FE1;
- provide and remove bridge resources to support a 3-way conversation;
- recognize clearing of one or all calls from a 3-way conversation;
- provide appropriate notifications towards FE3a and FE3b.

2.6.2.3 *Functionality of FE3a and FE3b for the Three-Party Service*

FE3a and FE3b represent the capability to receive notification information from FE2 and to transfer this information towards the remote users B and C respectively.

2.6.3 Relationship with a basic service

The functional entities for the Three-Party Service are represented as modular extensions to the functional model of the basic services, in Figure 2-2/Q.84.

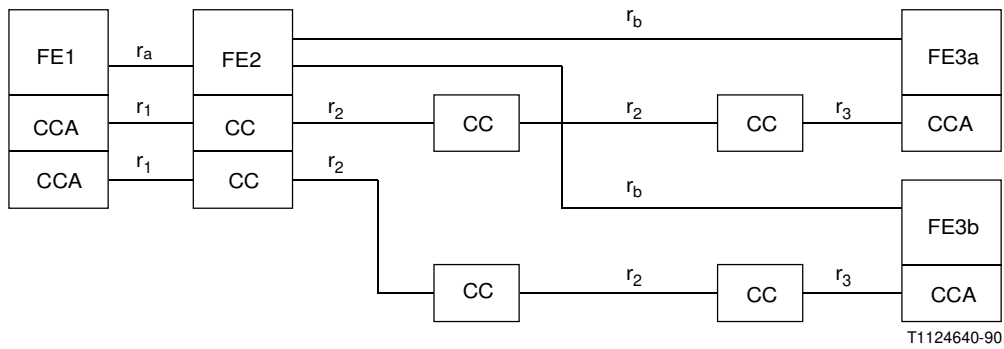

FIGURE 2-2/Q.84
Relationship with a basic service

2.7 Information flows

2.7.1 Information flow diagrams

The information flows for the Three-Party supplementary service are shown in Figures 2-3/Q.84 to 2-7/Q.84 for the following procedures:

Figure 2-3/Q.84 Begin 3-way conversation

Figure 2-4/Q.84 Split the 3-way conversation

Figure 2-5/Q.84 Disconnect call by remote user whilst in 3-way conversation mode

Figure 2-6/Q.84 Disconnect call by served user whilst in 3-way conversation mode

Figure 2-7/Q.84 Disconnect entire call by served user whilst in 3-way conversation mode.

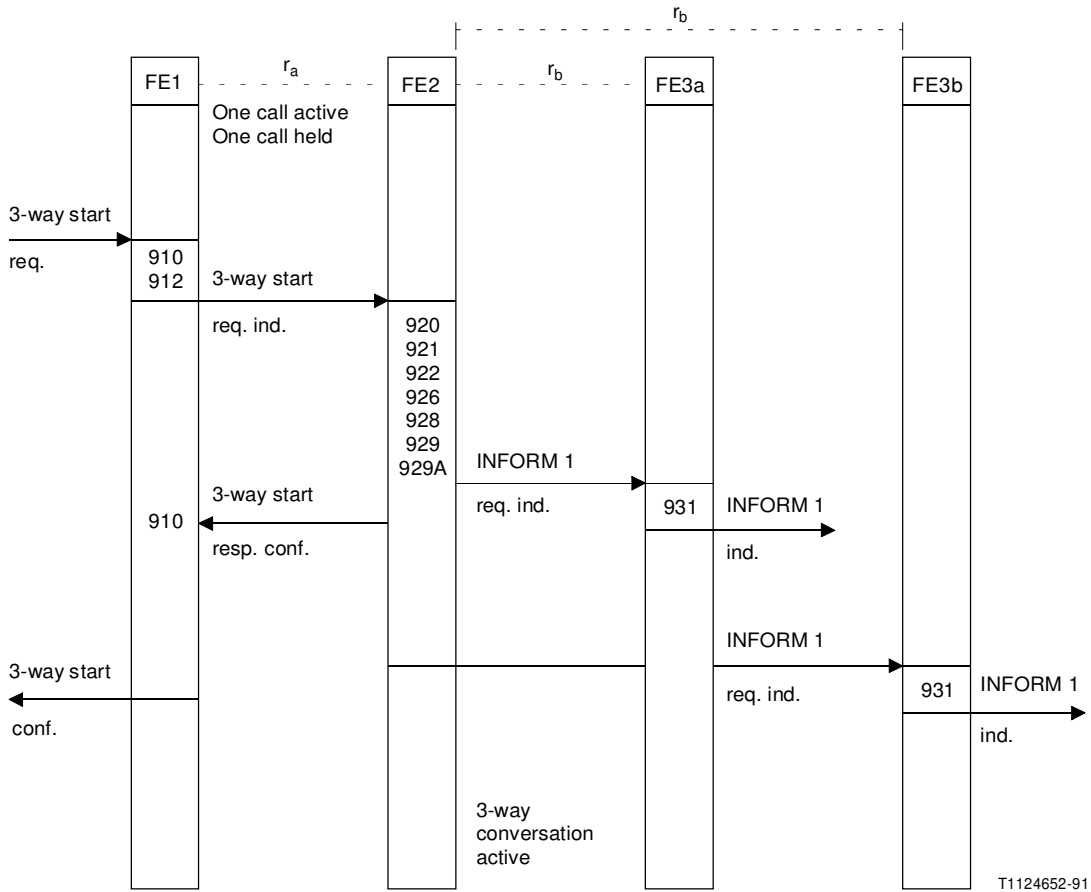

FIGURE 2-3/Q.84
Begin 3-way conversation

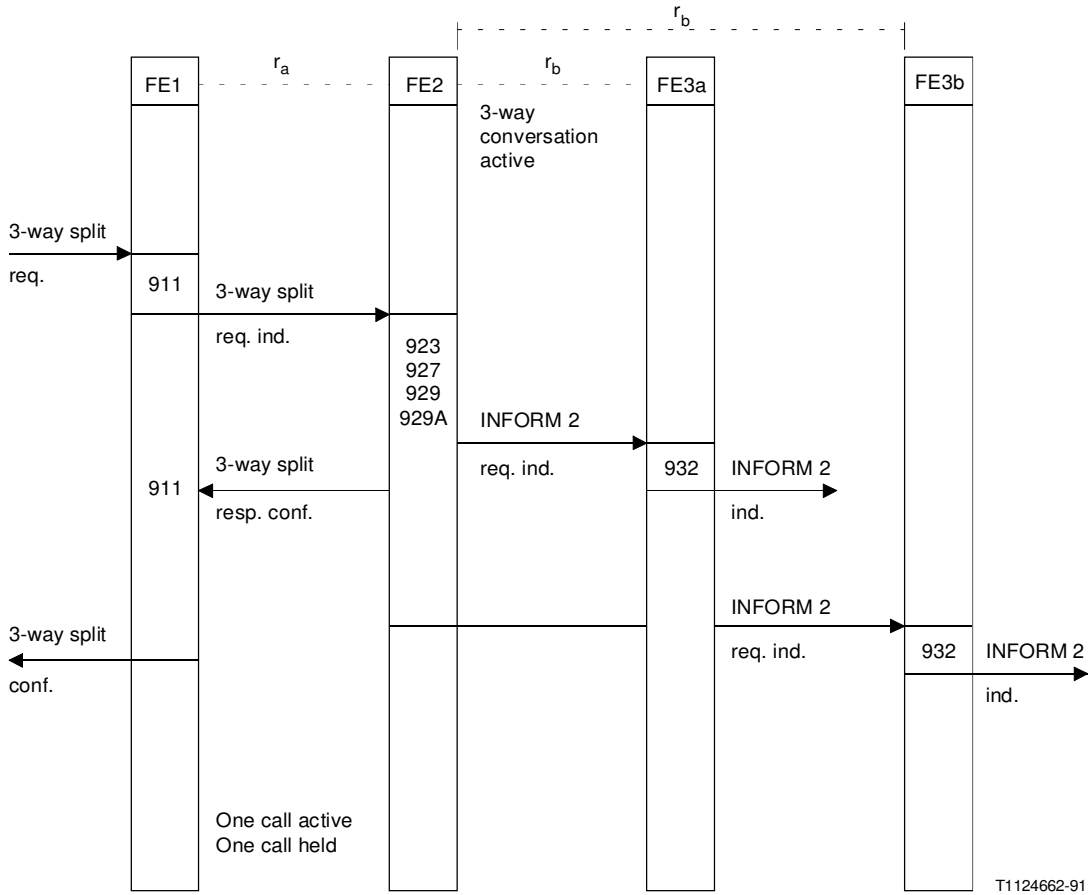

FIGURE 2-4/Q.84
Split the 3-way conversation

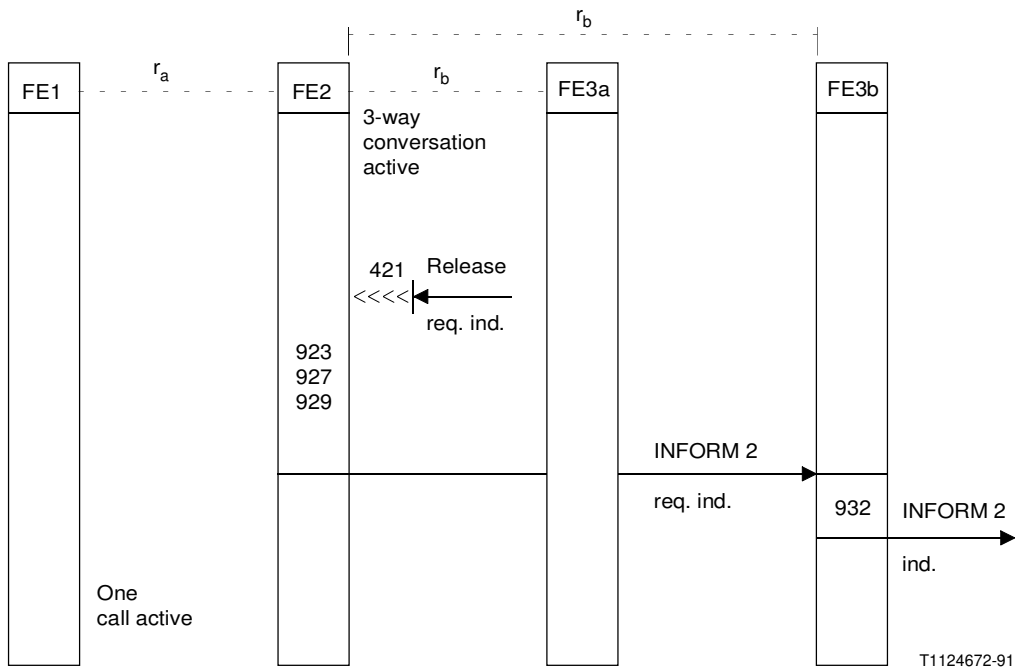
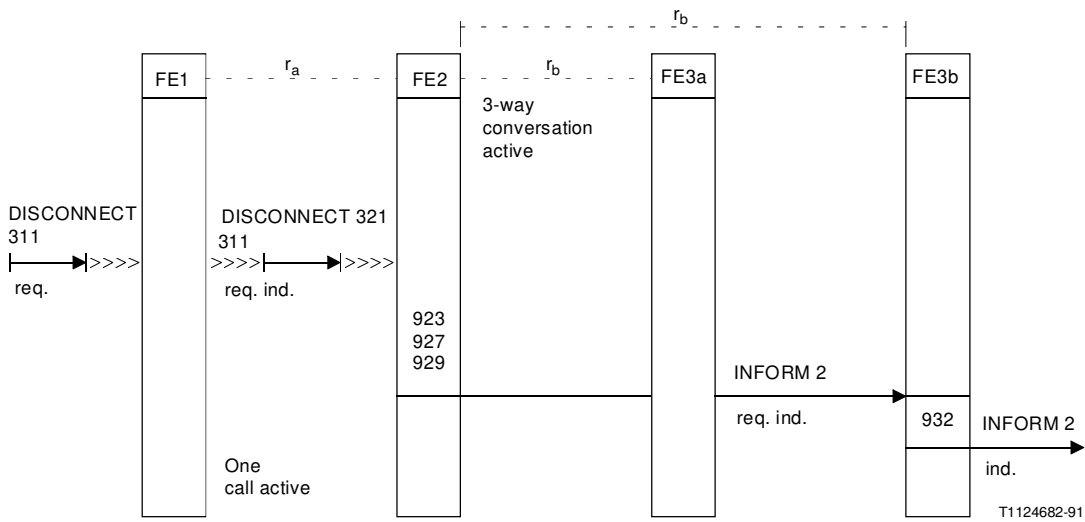

FIGURE 2-5/Q.84

Disconnect call by remote user whilst in 3-way conversation mode



Note – The disconnect-request (Figures 2-5/Q.84 and 2-6/Q.84) may belong either to the held or the active call. The latter may cause either a user initiated re-establishment of the remaining held call (retrieve) or the terminal implementation may provide an automatic retrieval without interruption of the remaining communication. These functions are implementation dependent, hence not further considered here.

FIGURE 2-6/Q.84

Disconnect call by served user whilst in 3-way conversation mode

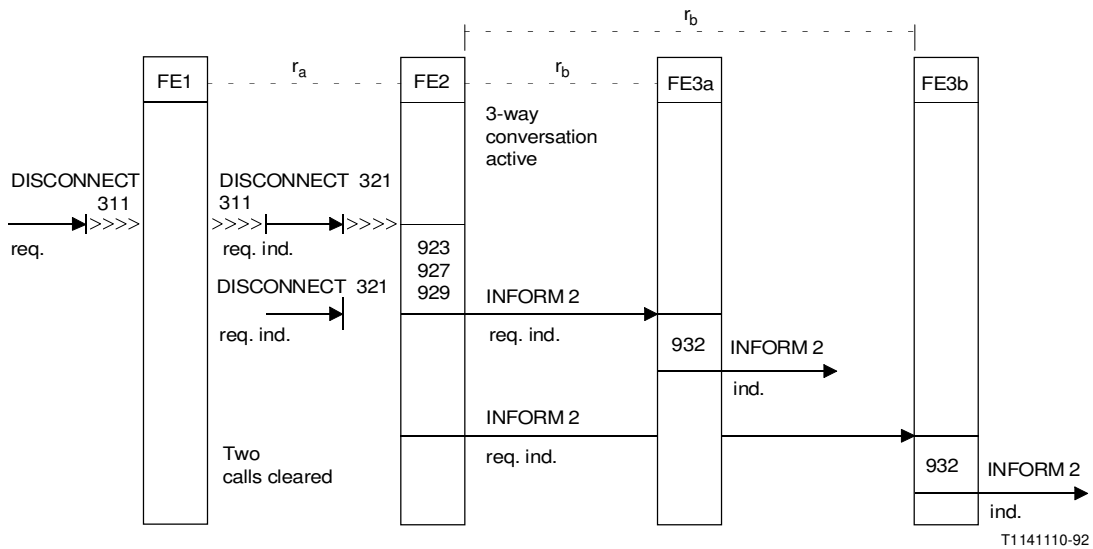

FIGURE 2-7/Q.84

Disconnect entire call by served user whilst in 3-way conversation mode

2.7.2 Definition of individual information flows

2.7.2.1 Relationship r_a

The contents of the information flows (see Figures 2-3/Q.84 and 2-4/Q.84) via relationship r_a and specific to the Three-Party supplementary service are given in the sections below.

2.7.2.1.1 Contents of 3-way start

TABLE 2-1/Q.84

Parameter	Allowed value	req. ind.	resp. conf.	resp. rej.
Cause	(Note)			Mandatory

This confirmed information flow initiates the bridging of the two calls into a 3-way conversation mode, the request shall be sent in the context of the held call.

Note – For allowed values see Recommendation Q.950 [6].

2.7.2.1.2 Contents of 3-way split

TABLE 2-2/Q.84

Parameter	Allowed value	req. ind.	resp. conf.	resp. rej.
Cause	(Note 2)			Mandatory

This confirmed information flow initiates the termination of the 3-way conversation mode.

Note 1 – The split-request may be followed by a terminal initiated interrupt of the active call (HOLD) and a subsequent re-establishment of the originally held call (RETRIEVE). These functions are considered as part of the hold service hence not further considered here.

Note 2 – For allowed values see Recommendation Q.950 [6].

2.7.2.2 Relationship r_b

INFORM 1 shall be used to inform the two remote parties that a multiparty call has been established.

INFORM 2 shall be used to inform the remote party that the multiparty call has been released and a single call exists between served user and the one remote party.

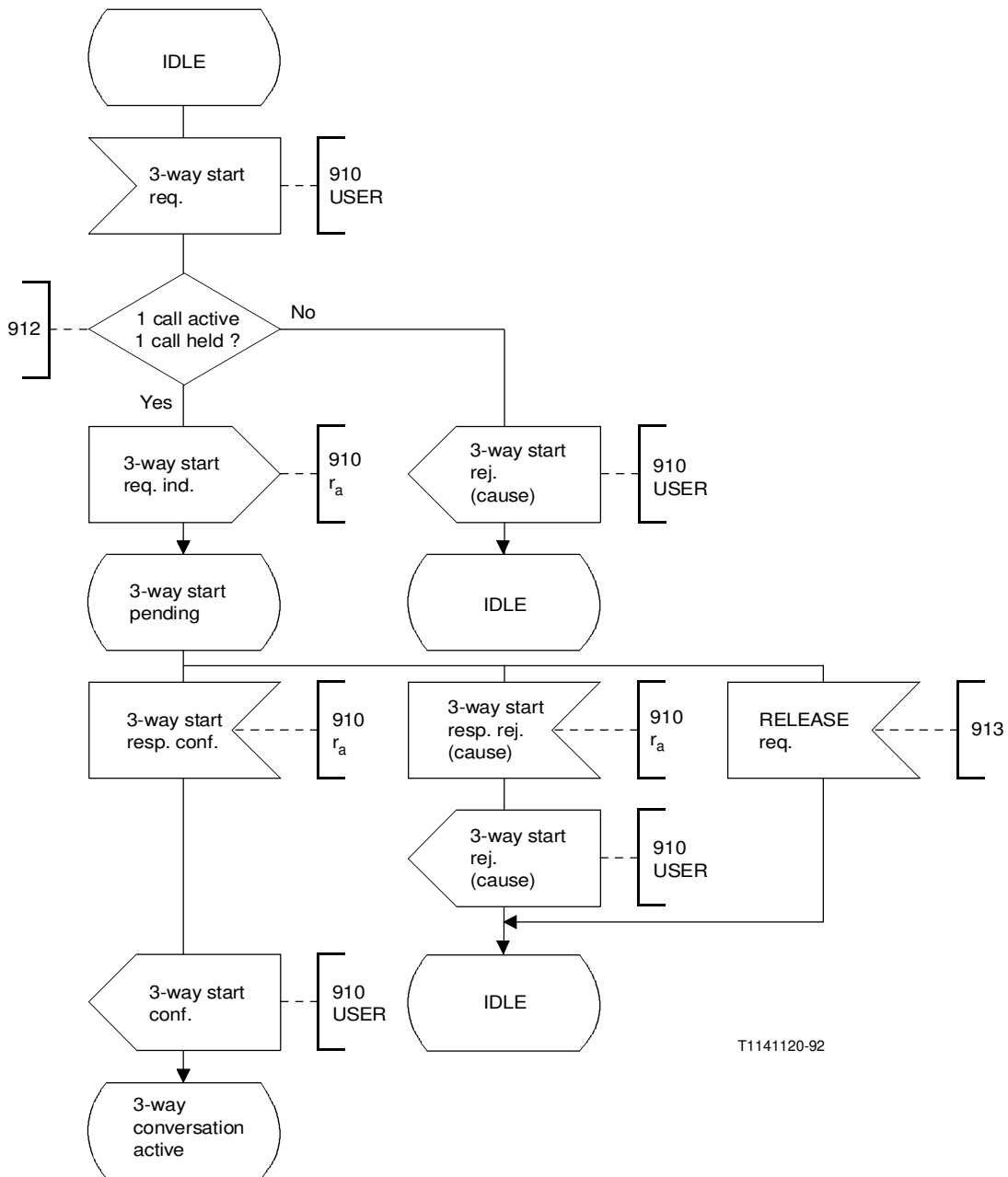

T1141120-92

FIGURE 2-8/Q.84 (sheet 1 of 2)

FE1

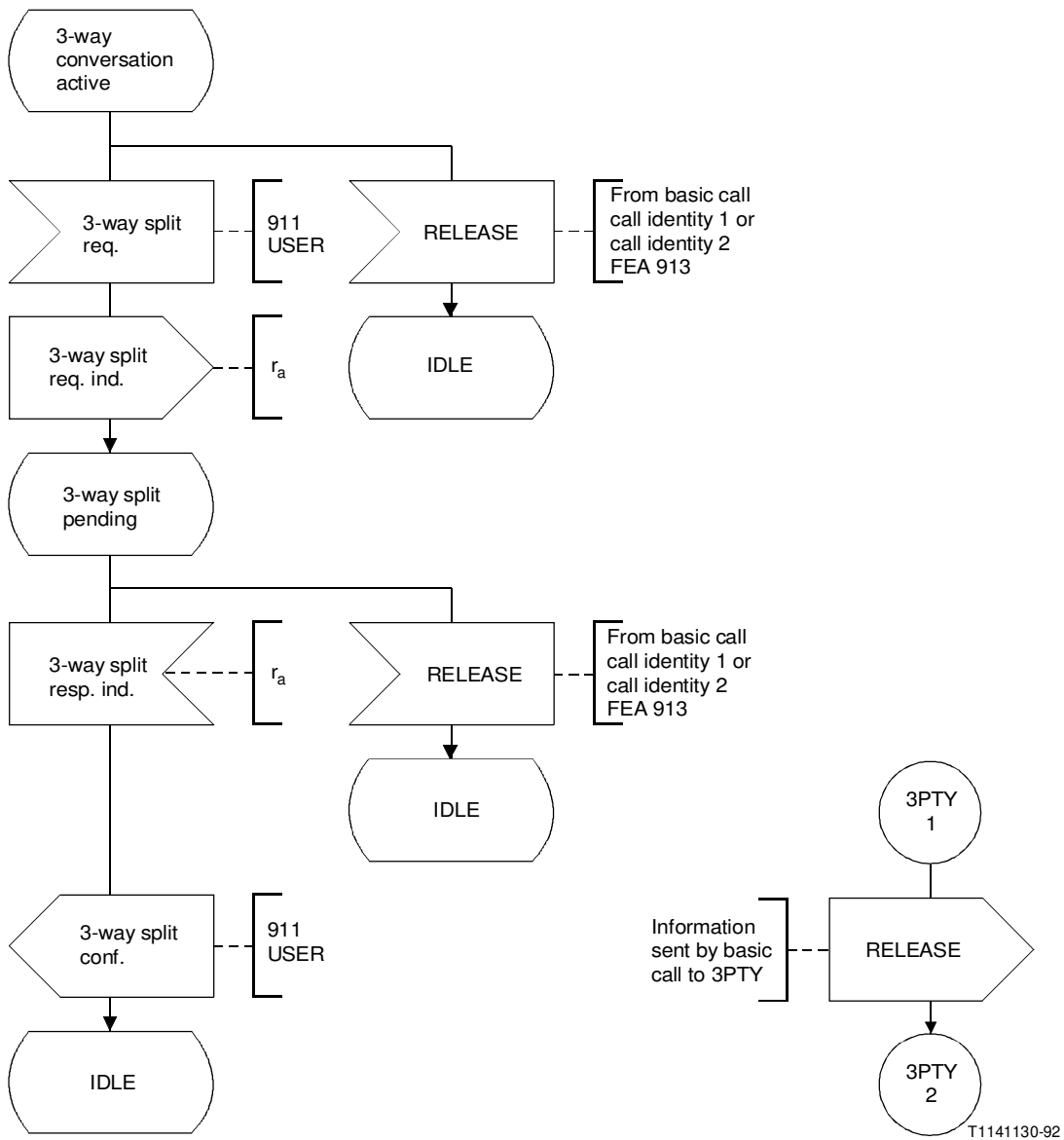

Note – 3PTY1 and 3PTY2 break basic call between connectors:
 – S1/15 and S1/16
 – S1/17 and S1/18
 – S1/19 and S1/20
 – S5/14 and S5/15
 – S5/19 and S5/20
 – S5/21 and S5/22
 of Recommendation Q.71 [5].

FIGURE 2-8/Q.84 (sheet 2 of 2)

FE1

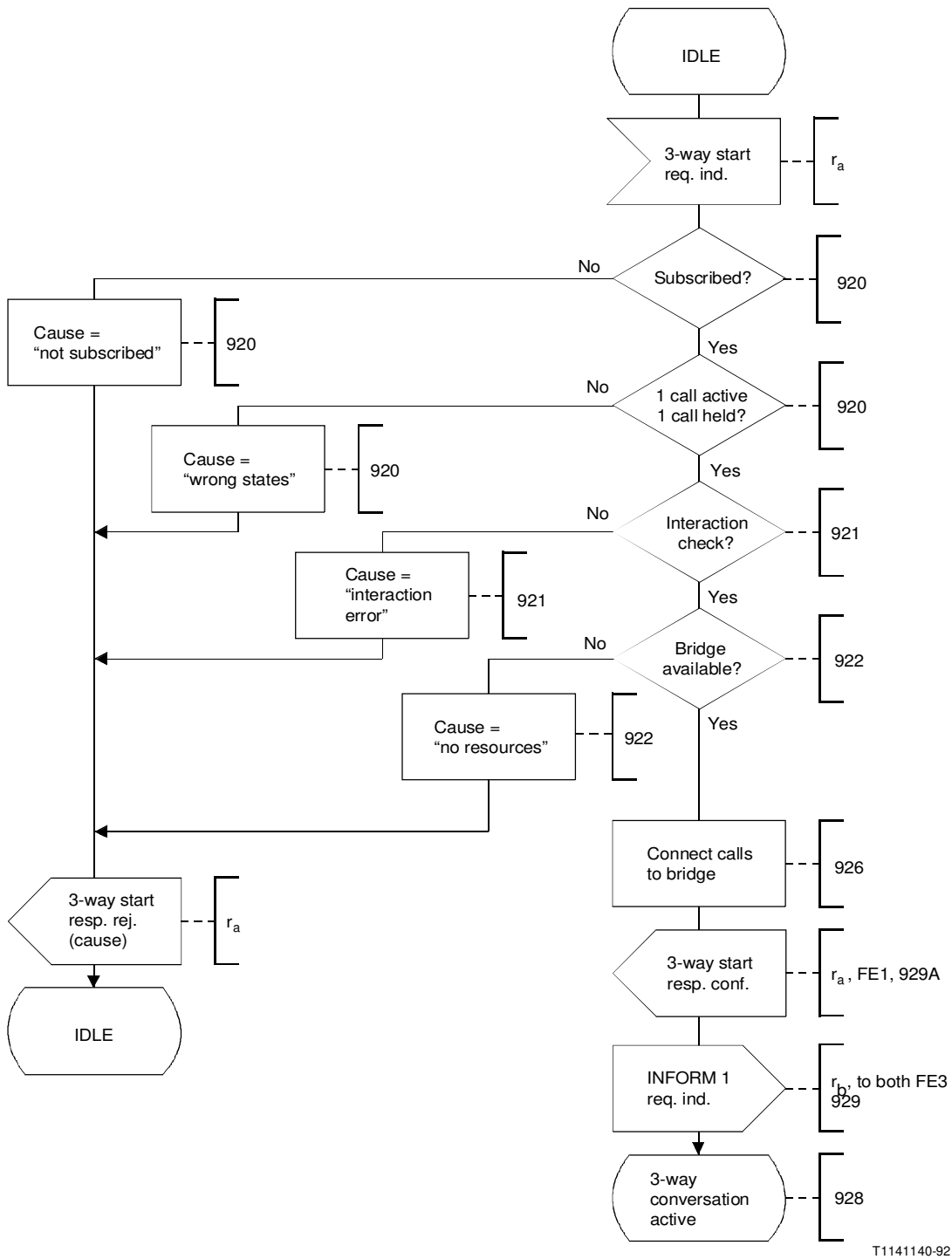
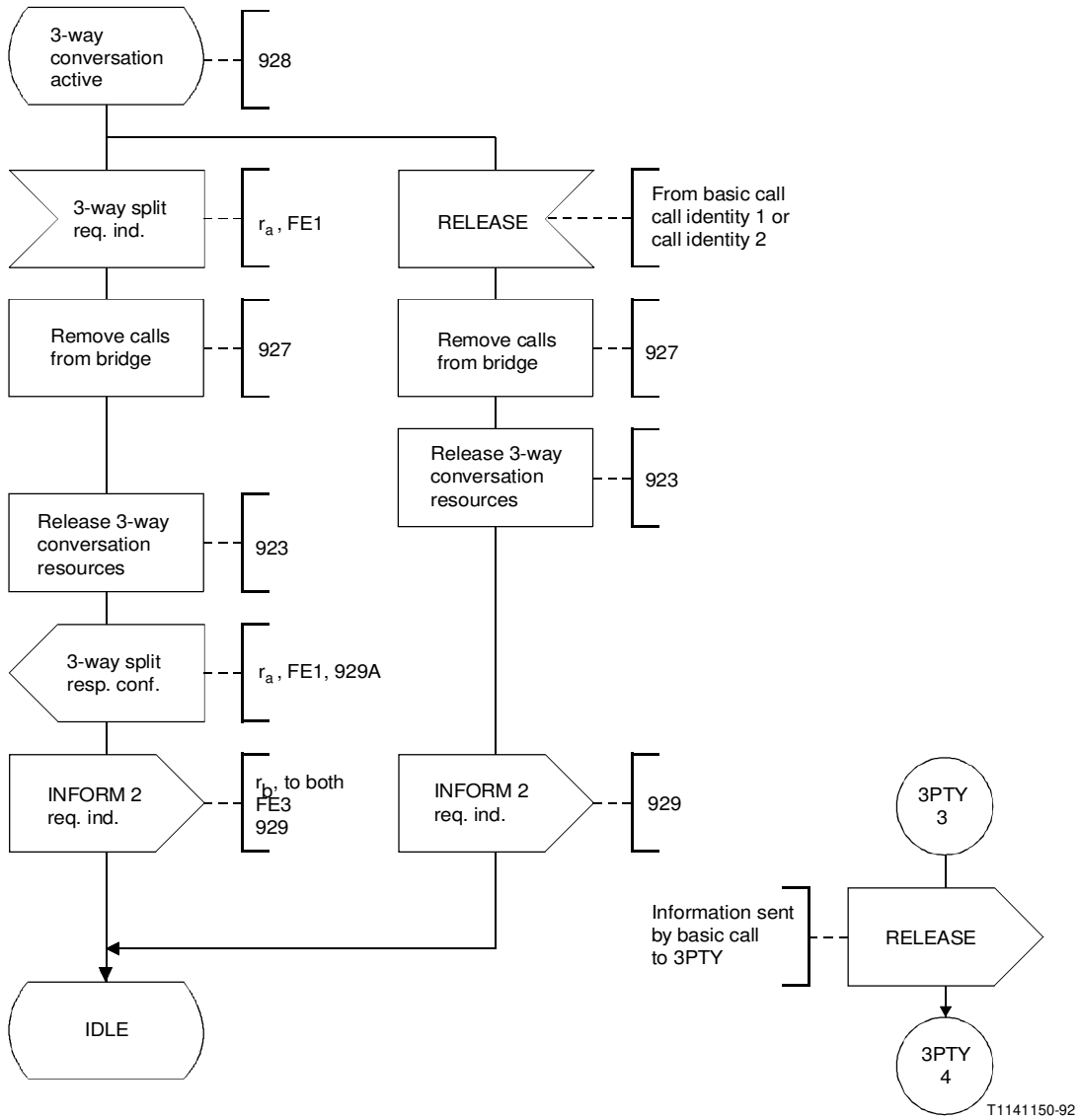

FIGURE 2-9/Q.84 (sheet 1 of 2)

FE2



Note – 3PTY and 3PTY4 break basic call between connectors:
 – S2/21 and S2/22
 – S2/23 and S2/24
 – S4/11 and S4/12
 – S4/7 and S4/8
 of Recommendation Q.71 [5].

FIGURE 2-9/Q.84 (sheet 2 of 2)

FE2

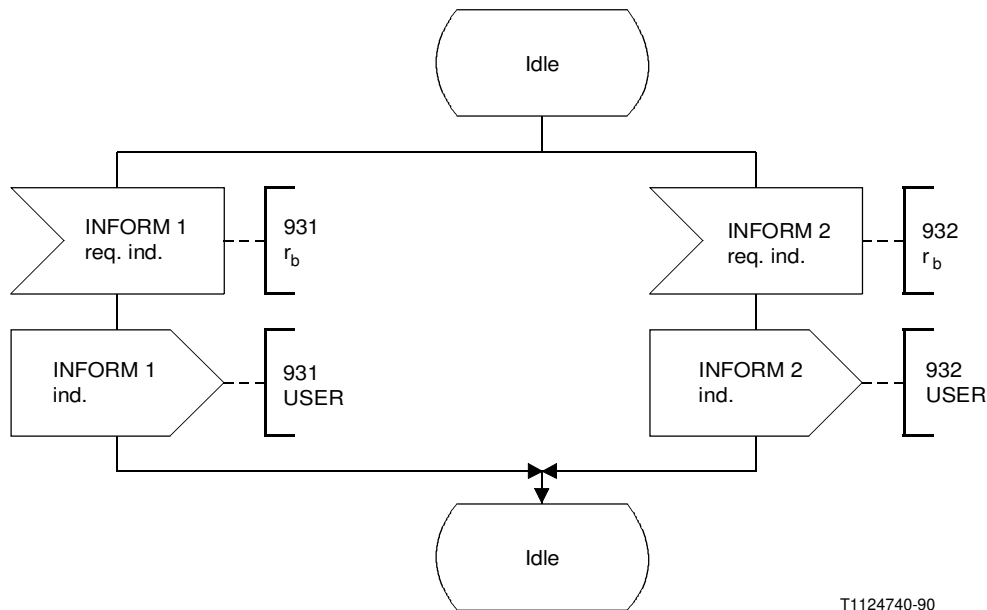

T1124740-90

FIGURE 2-10/Q.84
FE3a and FE3b

2.9 *Functional entity actions (FEAs)*

2.9.1 *FEAs of FE1*

910 The functional entity shall:

- recognize a user request for 3-way conversation start;
- generate and transfer a 3-way start request to FE2 or reject the user request if not valid;
- recognize a 3-way start response confirmation from FE2;
- transfer a service confirmation towards the user.

911 The functional entity shall:

- recognize a user for 3-way split;
- generate and transfer a 3-way split request to FE2;
- recognize a 3-way split response confirmation from FE2;
- transfer a service confirmation towards the user.

912 The functional entity shall check the states of the two calls involved.

913 The functional entity shall recognize a remote or local clearing request of either one of the calls or the entire 3-way conversation call.

2.9.2 *FEAs of FE2*

- 920 The functional entity shall:
- recognize a 3-way start request from FE1;
 - check for a valid start condition;
 - check and validate subscription options.
- 921 The functional entity shall:
- check for unauthorized interaction with other supplementary services;
 - check for authorized interaction with other supplementary services (e.g. matching of CUG information).
- 922 The functional entity shall seize resources (e.g. 3-way bridge), and record each successful invocation.
- 923 The functional entity shall release resources.
- 926 The functional entity shall connect the two calls to the bridge.
- 927 The functional entity shall remove the two calls from the bridge.
- 928 The functional entity shall control interaction with other supplementary services whilst in the 3-way active state.
- 929 The functional entity shall notify the remote users of either the establishment or the clearing of a multiparty call.
- 929A The functional entity shall respond (confirm or reject) to FE1's request to start a 3PTY-function.

2.9.3 *FEAs of FE3 (i.e. FE3a and FE3b)*

- 931 FE3 shall accept a 3-way start notification and relay it to the user.
- 932 FE3 shall accept a 3-way end notification and relay it to the user.

2.10 *Allocation of functional entities to physical locations*

The possible locations of functional entities FE1, FE2, FE3a and FE3b are shown in Table 2-3/Q.84

TABLE 2-3/Q.84

Scenario	FE1	FE2	FE3a	FE3b
I	TE	LE	TE	TE
II	TE	PNX	TE	TE

2.11 *Interaction with other supplementary services*

2.11.1 *Advice of charge services*

2.11.1.1 *AOC, charging information at call set-up time*

Neither supplementary service affects the operation of the other supplementary services.

2.11.1.2 *AOC, charging information during the call*

There is no impact on the advice of charge provision. Some networks may not be able to give charge information for the use of 3-way conversation resources.

2.11.1.3 *AOC, charging information at the end of a call*

Neither supplementary service affects the operation of the other supplementary services.

2.11.2 *Call Waiting*

Neither supplementary service affects the operation of the other supplementary services.

2.11.3 *Call Hold*

Any party involved in a 3-way conversation, shall be able to invoke the Hold service in order to put the 3-way conversation on hold. In case of a hold-request sent by the served user during the 3-way conversation active phase, no notifications shall be sent towards the remote users.

2.11.4 *Call Transfer*

It shall not be possible to transfer any of the two calls involved in a 3-way conversation. This has to be checked by FE2.

2.11.5 *Number identification services*

2.11.5.1 *Calling Line Identification Presentation*

Neither supplementary service affects the operation of the other supplementary services.

2.11.5.2 *Calling Line Identification Restriction*

Neither supplementary service affects the operation of the other supplementary services.

2.11.5.3 *Connected Line Identification Presentation*

Neither supplementary service affects the operation of the other supplementary services.

2.11.5.4 *Connected Line Identification Restriction*

Neither supplementary service affects the operation of the other supplementary services.

2.11.6 *Closed User Group*

3-way conversation activation requires a validation check (FE2) of the CUG indexes of the calls involved so as to avoid misuse. The CUG information shall be stalled at FE2.

2.11.7 *Completion of Calls to Busy Subscriber*

Neither supplementary service affects the operation of the other supplementary services.

2.11.8 *Conference services*

2.11.8.1 *Conference Call, Add-on*

It shall be possible for each party of a 3-way conversation to be involved alternatively in the 3-way conversation and an add-on conference.

2.11.8.1.1 *Served User*

In order to convert a three-way conversation into an add-on conference the served user shall cancel the Three-Party supplementary service first and then shall invoke the add-on conference from the active call. Subsequently, the held call can be added to the conference.

2.11.8.1.2 *Add-on conference controlled by another party*

The network shall not be required to prevent that a leg to one of the remote parties can be part of an add-on conference controlled by that party.

Note – In the cases of multiple bridges controlled by the same served user it is not possible to prevent two multiparty calls being joined.

2.11.8.2 *Meet-me Conference*

A service provider may take appropriate measures to prevent a meet-me conference call from being joined with another call into a 3-way conversation. The associated procedures are outside the scope of this Recommendation.

2.11.9 *Direct-Dialling-in*

Neither supplementary service affects the operation of the other supplementary services.

2.11.10 *Diversion services*

Neither supplementary service affects the operation of the other supplementary services.

2.11.11 *Freephone*

Neither supplementary service affects the operation of the other supplementary services.

2.11.12 *Malicious Call Identification*

Neither supplementary service affects the operation of the other supplementary services.

2.11.13 *Multiple Subscriber Number*

Neither supplementary service affects the operation of the other supplementary services.

2.11.14 *Sub-addressing*

Neither supplementary service affects the operation of the other supplementary services.

2.11.15 *Terminal Portability*

Terminal portability shall not be available whilst in 3-way conversation mode. This has to be avoided by FE2.

2.11.16 *Three-Party Service*

After setting up a 3-way conversation the served user cannot invoke a second 3-way conversation involving the original three-way call until that call is released or split.

Note – In the cases of multiple bridges controlled by the same served user it is not possible to prevent two multiparty calls being joined.

2.11.17 *User-to-User Signalling*

Neither supplementary service affects the operation of the other supplementary services.