



INTERNATIONAL TELECOMMUNICATION UNION

ITU-T

TELECOMMUNICATION
STANDARDIZATION SECTOR
OF ITU

Q.82

(03/93)

**GENERAL RECOMMENDATIONS
ON TELEPHONE SWITCHING
AND SIGNALLING**

**FUNCTIONS AND INFORMATION FLOWS
FOR SERVICES IN THE ISDN**

**STAGE 2 DESCRIPTION FOR CALL
OFFERING SUPPLEMENTARY SERVICES
CLAUSE 2 – CALL FORWARDING
CLAUSE 3 – CALL DEFLECTION**

ITU-T Recommendation Q.82

(Previously “CCITT Recommendation”)

FOREWORD

The ITU Telecommunication Standardization Sector (ITU-T) is a permanent organ of the International Telecommunication Union. The ITU-T is responsible for studying technical, operating and tariff questions and issuing Recommendations on them with a view to standardizing telecommunications on a worldwide basis.

The World Telecommunication Standardization Conference (WTSC), which meets every four years, established the topics for study by the ITU-T Study Groups which, in their turn, produce Recommendations on these topics.

ITU-T Recommendation Q.82 was revised by the ITU-T Study Group XI (1988-1993) and was approved by the WTSC (Helsinki, March 1-12, 1993).

NOTES

1 As a consequence of a reform process within the International Telecommunication Union (ITU), the CCITT ceased to exist as of 28 February 1993. In its place, the ITU Telecommunication Standardization Sector (ITU-T) was created as of 1 March 1993. Similarly, in this reform process, the CCIR and the IFRB have been replaced by the Radiocommunication Sector.

In order not to delay publication of this Recommendation, no change has been made in the text to references containing the acronyms "CCITT, CCIR or IFRB" or their associated entities such as Plenary Assembly, Secretariat, etc. Future editions of this Recommendation will contain the proper terminology related to the new ITU structure.

2 In this Recommendation, the expression "Administration" is used for conciseness to indicate both a telecommunication administration and a recognized operating agency.

© ITU 1994

All rights reserved. No part of this publication may be reproduced or utilized in any form or by any means, electronic or mechanical, including photocopying and microfilm, without permission in writing from the ITU.

CONTENTS

	<i>Page</i>
2 Call forwarding	1
2.1 Scope	1
2.2 References	2
2.3 Definitions	2
2.4 Symbols and abbreviations	3
2.5 Description	3
2.6 Derivation of the functional model	4
2.7 Information flows	4
2.8 SDL diagrams for functional entities	19
2.9 Functional entity actions	37
2.10 Allocation of functional entities to physical locations	39
Annex A	40
Annex B – Activation, deactivation, registration and interrogation	42
3 Call deflection	51
3.1 Scope	51
3.2 References	52
3.3 Definitions	52
3.4 Symbols and abbreviations	53
3.5 Description	53
3.6 Derivation of the functional model	53
3.7 Information flow	55
3.8 SDL diagrams for functional entities	65
3.9 Functional entity actions	81
3.10 Allocation of functional entities to physical locations	83
Annex A – Multiple diversion address handling	84

SUMMARY

This Recommendation provides the Stage 2 description for the Call Forwarding supplementary services, supported by an ISDN. The Stage 2 descriptions are comprised of the switching functions and the signalling information flows.

The Call Forwarding Unconditional supplementary service permits a served user to have the network send to another number all incoming calls for the served user's number (or just those associated with a specified basic service). The served user's originating service is unaffected. If this service is activated, calls are forwarded no matter what the condition of the termination.

The Call Forwarding on Busy supplementary service permits a served user to have the network send to another number all incoming calls for the served user's number (or just those associated with a specified basic service) which meet busy at the served user's ISDN number. The served user's originating service is unaffected.

The Call Forwarding on No Reply supplementary service permits a served user to have the network send to another number all incoming calls for the serviced user's number (or just those associated with a specified basic service) which meet no reply at the served user's ISDN number. The served user's originating service is unaffected.

This Recommendation provides the Stage 2 description for the Call Deflection supplementary service, supported by an ISDN.

The Stage 2 descriptions are comprised of the switching functions and the signalling information flows.

The Call Deflection supplementary service permits a serviced user to, in real time, request that the network redirects an incoming call addressed to the served user's ISDN number to another number. The served user's originating service is unaffected.

STAGE 2 DESCRIPTION FOR CALL OFFERING SUPPLEMENTARY SERVICES

(Melbourne, 1988; modified at Helsinki, 1993)

2 Call forwarding

2.1 Scope

This Recommendation defines the Stage 2 for the Call Forwarding supplementary services (CFB, CFNR, CFU) of Integrated Services Digital Network (ISDN) as provided by public telecommunications operators. Stage 2 identifies the functional capabilities and the information flows needed to support the service description. The Stage 2 description also identifies user operations not directly associated with a call (see Recommendation I.130 [1]).

This Recommendation is specified according to the methodology specified in Recommendation Q.65 [2].

This Recommendation does not formally describe the relationship between this supplementary service and the basic call, but where possible this information is included for guidance.

In addition, this Recommendation does not specify the requirements where the service is provided to the user via a private ISDN. This Recommendation does not specify the requirements for the allocation of defined functional entities within a private ISDN; it does however define which functional entities may be allocated to a private ISDN.

This Recommendation does not specify the additional requirements where the service is provided to the user via a telecommunications network that is not an ISDN.

This Recommendation describes the three versions of Call Forwarding supplementary services, when implemented using the “forward switching” network routing algorithm and partial rerouting at the public/private network interface as contained in Recommendation Q.80 [3].

The description of full rerouting as described in Recommendation Q.80 is outside the scope of this Recommendation.

The procedures for the activation/deactivation/registration of the forwarding services are contained in Annex B.

The CFU supplementary service permits a served user to have the network send to another number all incoming calls for the served user’s number (or just those associated with a specified basic service). The served user’s originating service is unaffected. If this service is activated, calls are forwarded no matter the condition of the termination.

The CFB supplementary service permits a served user to have the network send to another number all incoming calls for the served user’s number (or just those associated with a specified basic service) which meet busy at the served user’s ISDN number. The served user’s originating service is unaffected.

The CFNR supplementary service permits a served user to have the network send to another number all incoming calls for the served user’s number (or just those associated with a specified basic service) which meet no reply at the served user’s ISDN number. The served user’s originating service is unaffected.

The forwarded-to number is registered with the network for use on all calls.

This Recommendation is applicable to the Stage 3 Recommendations for the ISDN Forwarding supplementary services CFB, CFNR and CFU. The term "Stage 3" is also defined in Recommendation I.130 [1]. Where the text indicated the status of a requirement, i.e. as strict command or prohibition, as authorization leaving freedom, as a capability or possibility, this shall be reflected in the text of the relevant Stage 2 and Stage 3 Recommendations.

Furthermore, conformance to this Recommendation is met by conforming to the Stage 3 Recommendations with the field of application appropriate to the equipment being implemented. Therefore no method of testing is provided for this Recommendation.

2.2 References

This Recommendation incorporates by dated or undated reference, provisions from other publications. These references are cited at the appropriate places in this Recommendation and the publications are listed hereafter. For dated references, subsequent amendments to, or revisions of any of these publications apply to this Recommendation only when incorporated in it by amendment or revision. For undated references, the latest edition of the publication referred to applies.

- [1] CCITT Recommendation I.130 *Method for the characterization of telecommunication services supported an ISDN and network capabilities of an ISDN*, 1988.
- [2] CCITT Recommendation Q.65 *Stage 2 of the method for the characterization of services supported by ISDN*, 1988.
- [3] CCITT Recommendation Q.80 *Introduction to stage 2 service descriptions for supplementary services*, 1988.
- [4] CCITT Recommendation Q.71 *ISDN 64 kbit/s circuit mode switched bearer service*, 1992.
- [5] CCITT Recommendation I.112 *Vocabulary of terms for ISDNs*, 1988.
- [6] CCITT Recommendation E.164 *Numbering plan for the ISDN era*, 1988.
- [7] CCITT Recommendation I.252.2 *Call Forwarding Busy (CFB)*, 1992.
- [8] CCITT Recommendation I.252.3 *Call Forwarding No Reply (CFNR)*, 1992.
- [9] CCITT Recommendation I.252.4 *Call Forwarding Unconditional (CFU)*, 1992.

2.3 Definitions

For the purposes of this Recommendation, the following definitions apply:

Integrated Services Digital Network (ISDN): See 2.3/I.112 [5], definition 308.

Service - telecommunications service: See 2.2/I.112 [5], definition 201.

ISDN number: A number conforming to the numbering plan and structure specified in Recommendation E.164 [6].

originally called number: The number of the B1-party.

connected number: The number of the final destination (C-party).

forwarding number: The number of the served user, i.e. the subscriber who initiates the forwarding service and from where the call has been forwarded.

forwarded-to number (FTN): The number to which a call has been forwarded.

forwarding indicator (FI): Indicator showing that a call has been forwarded and indicating whether this information should be given to the calling party.

forwarding indication: Indication for the served user that forwarding has occurred.

presentation indicator (PI): Indicator showing whether the FTN should be presented to the calling user, as derived from the C-party's COLR supplementary service.

forwarding cause: Parameter which contains the reason for the forwarding, e.g. CFU, CFB, CFNR, CD.

network facility indicator (NFI): Indicator showing the preferred transit network or a network specific facility to be used for forwarding.

2.4 Symbols and abbreviations

Abbreviations used:

BC	Basic Call
CC	Call Control
CCA	Call Control Agent
CD	Call Deflection
CFB	Call Forwarding on Busy
CFNR	Call Forwarding No Reply
CFPC	Call Forwarding Profile Control
CFU	Call Forwarding Unconditional
FC	Forwarding Cause
FE	Functional Entry
FI	Forwarding Indicator
FTN	Forwarded-to Number
GD	Global Data
LE	Local Exchange
NDUB	Network Determined User Busy
NFI	Network Facility Indicator
NSO	Notification Subscription Option
PI	Presentation Indicator
PN	Private Network
PNX	Private Network Exchange
SCE	Service Control Entity
SCM	Service Control Model
TE	Terminal Equipment
UDUB	User Determined User Busy

2.5 Description

The general description of the CFB supplementary service is specified in I.252.2 [7].

The general description of the CFNR supplementary service is specified in I.252.3 [8].

The general description of the CFU supplementary service is specified in I.252.4 [9].

2.6 Derivation of the functional model

2.6.1 Functional model description

The functional model for the CF supplementary service is shown in Figure 2-1.

NOTE – The addition of the functional model for the activation/deactivation/registration of the forwarding services is contained in Figure B.2-1.

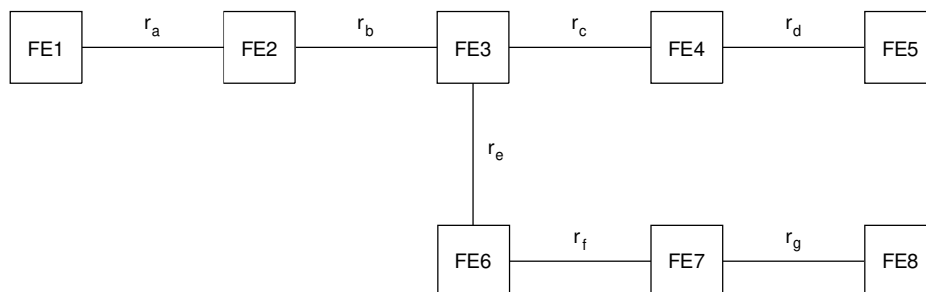

TI 126410-90/d01

FIGURE 2-1/Q.82
Functional model

2.6.2 Description of the functional entities

The functional entities required by the CF supplementary service in addition to those of the basic call are as follows:

- FE1: Caller's service agent
- FE2: Caller's service control entity
- FE3: Call forwarding execution entity
- FE4: Call forwarding detection and control entity
- FE5: Served user's service agent
- FE6: Interface controlling entity
- FE7: Forwarded-to user's service control entity
- FE8: Forwarded-to user's service agent

2.6.3 Relationship with a basic service

The relationship with a basic service is shown in Figure 2-2.

NOTE – The relationship in Figure 2-3 covers scenarios 8 and 9 in 2.10.

2.7 Information flows

2.7.1 Information flows diagram

The information flows for the Call Forwarding supplementary service are shown in Figures 2-4 to 2-12.

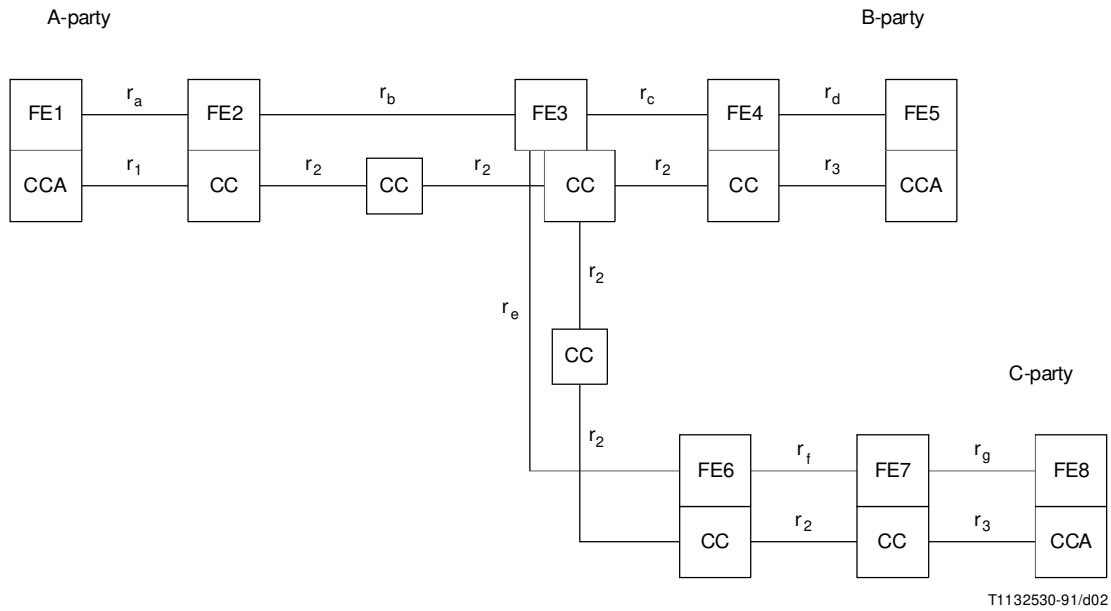

FIGURE 2-2/Q.82
Relationship with a basic service

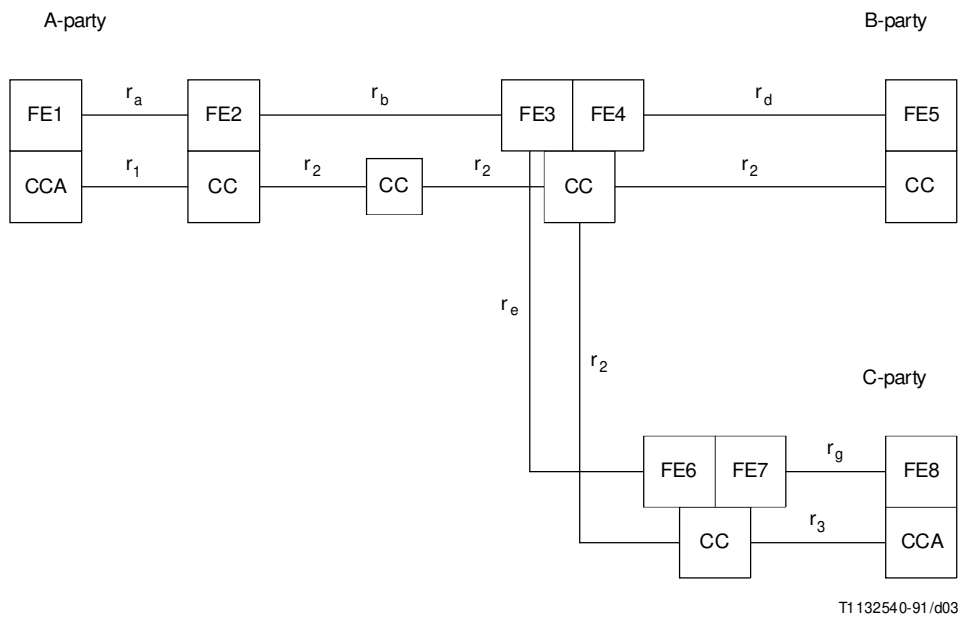
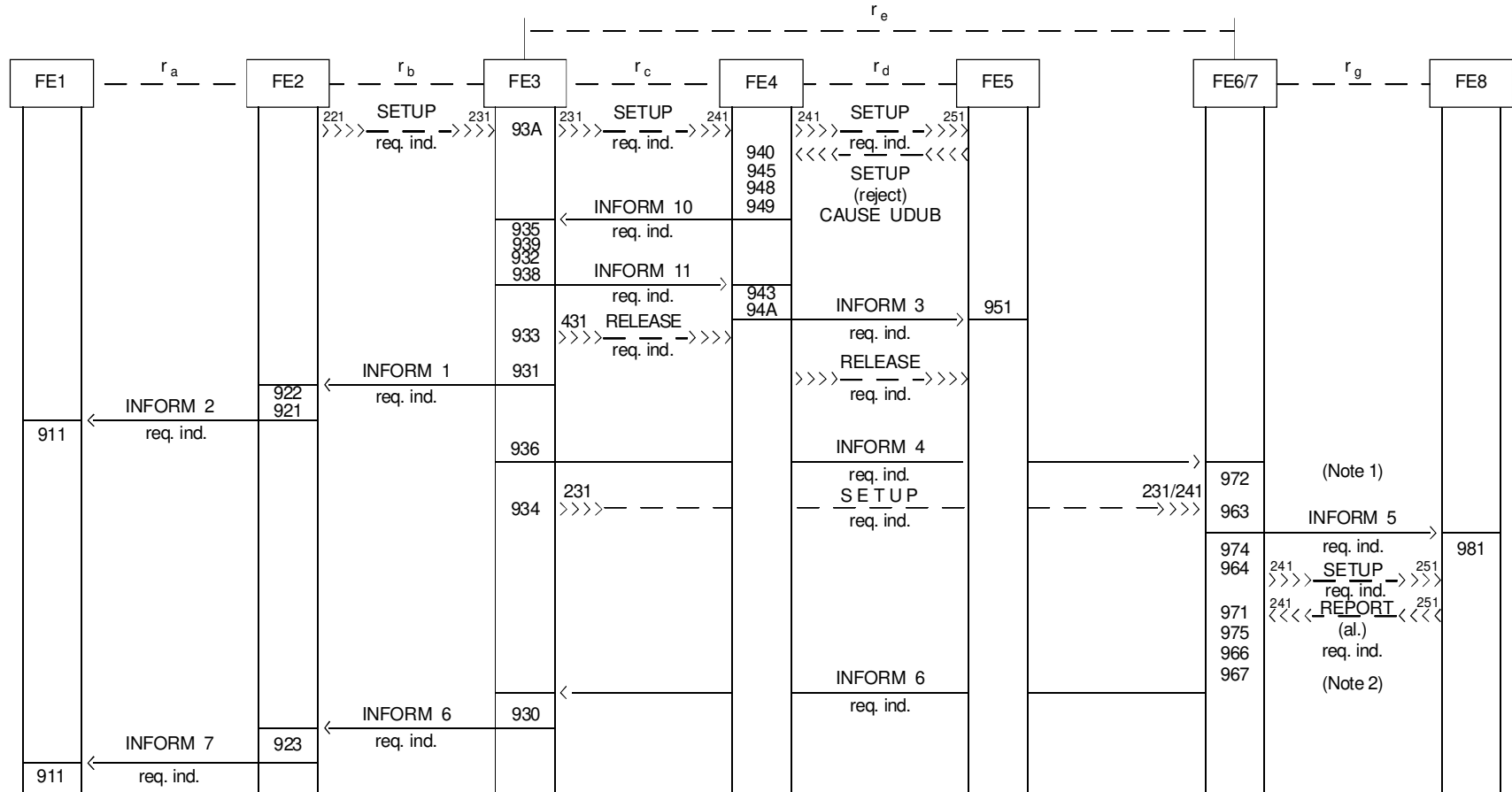

FIGURE 2-3/Q.82



T1144110-92/d04

NOTE – The notes are found after Figure 2-12.

FIGURE 2-4/Q.82
Information flow of CFB, UDUB

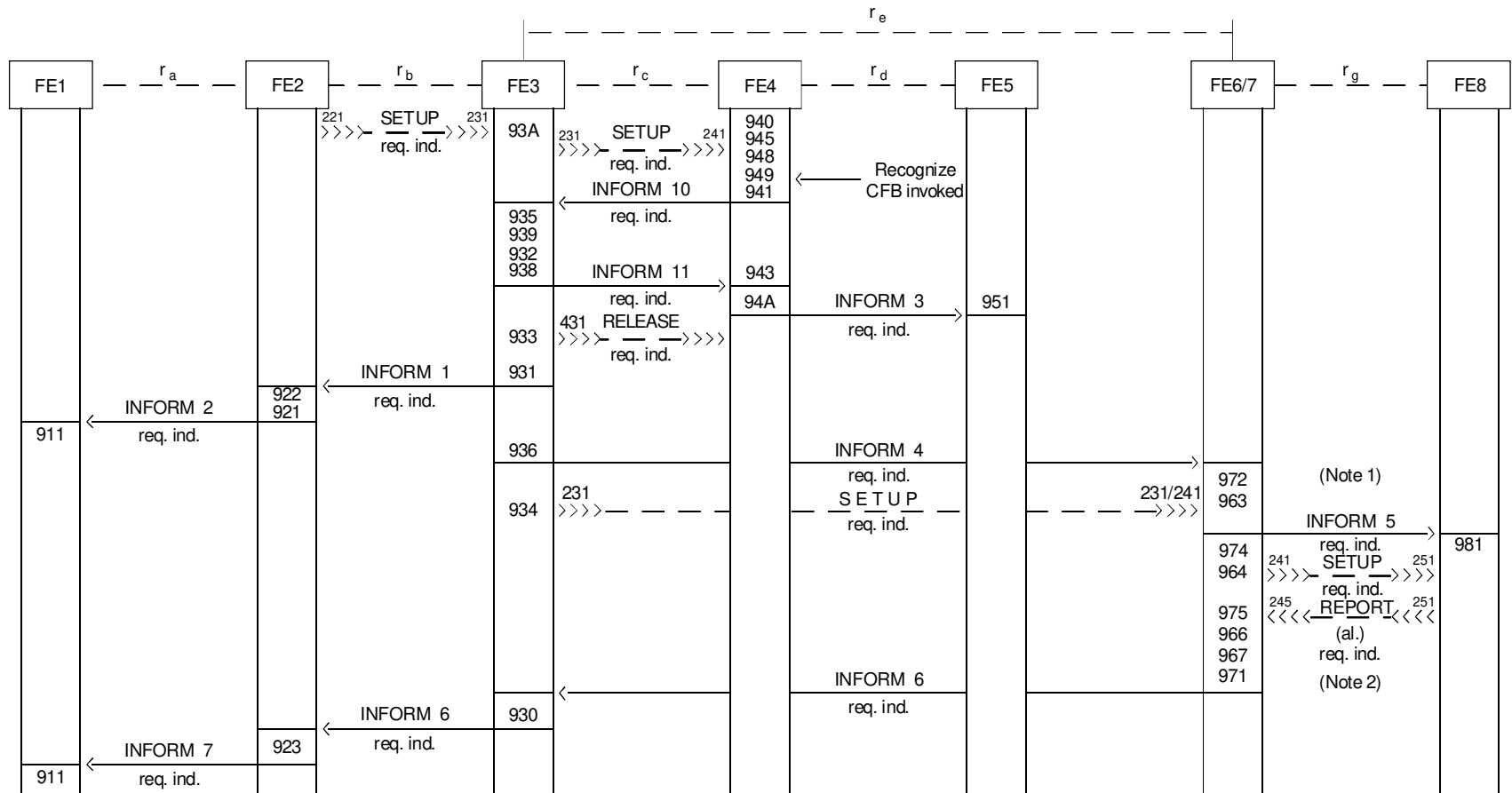

T1144120-92/d05

NOTE – The notes are found after Figure 2-12.

FIGURE 2-5/Q.82
Information flow of CFB, NDUB

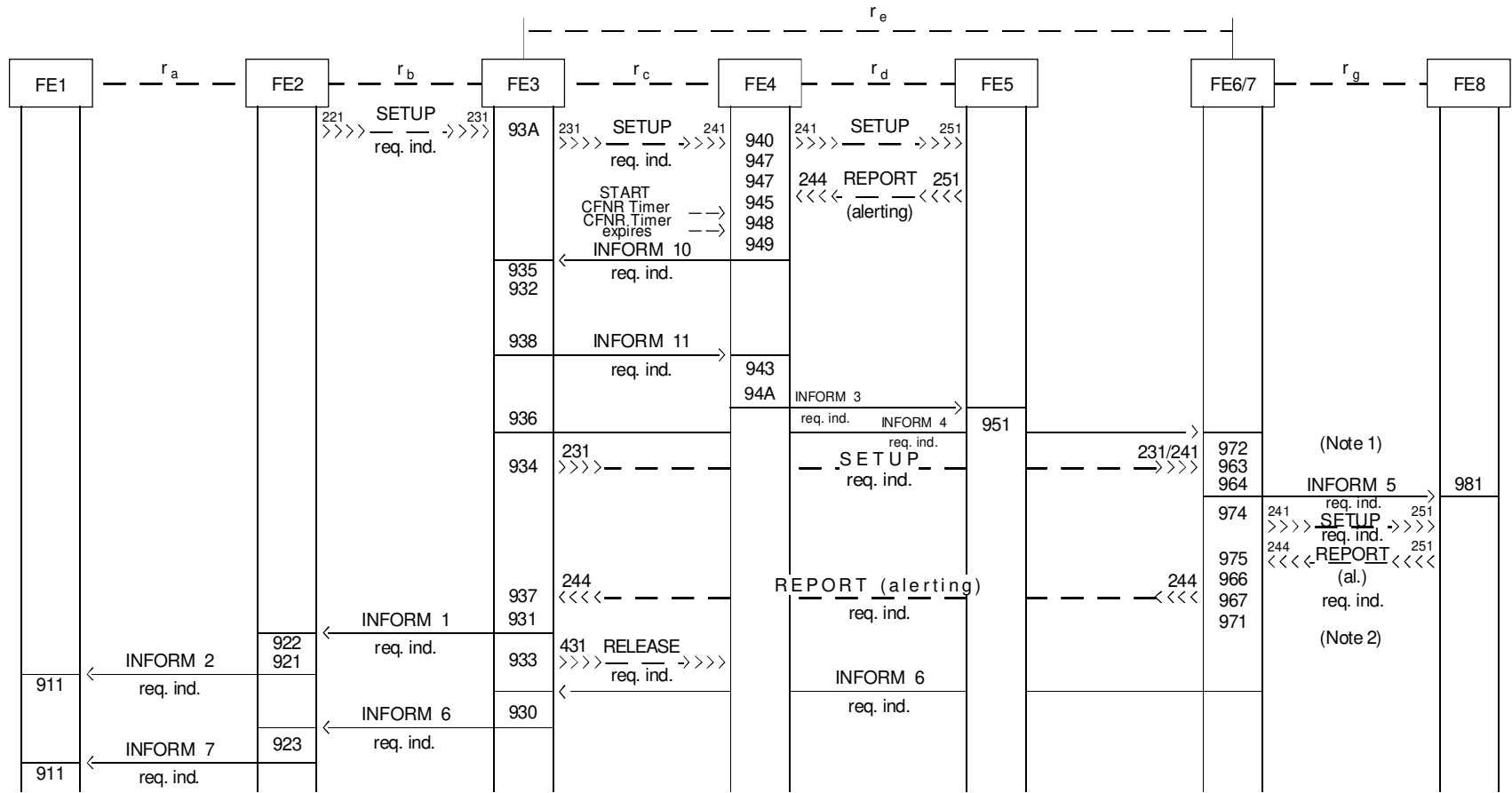

T1144130-92/d06

NOTE – The notes are found after Figure 2-12.

FIGURE 2-6/Q.82
CFNR, Option A, late release

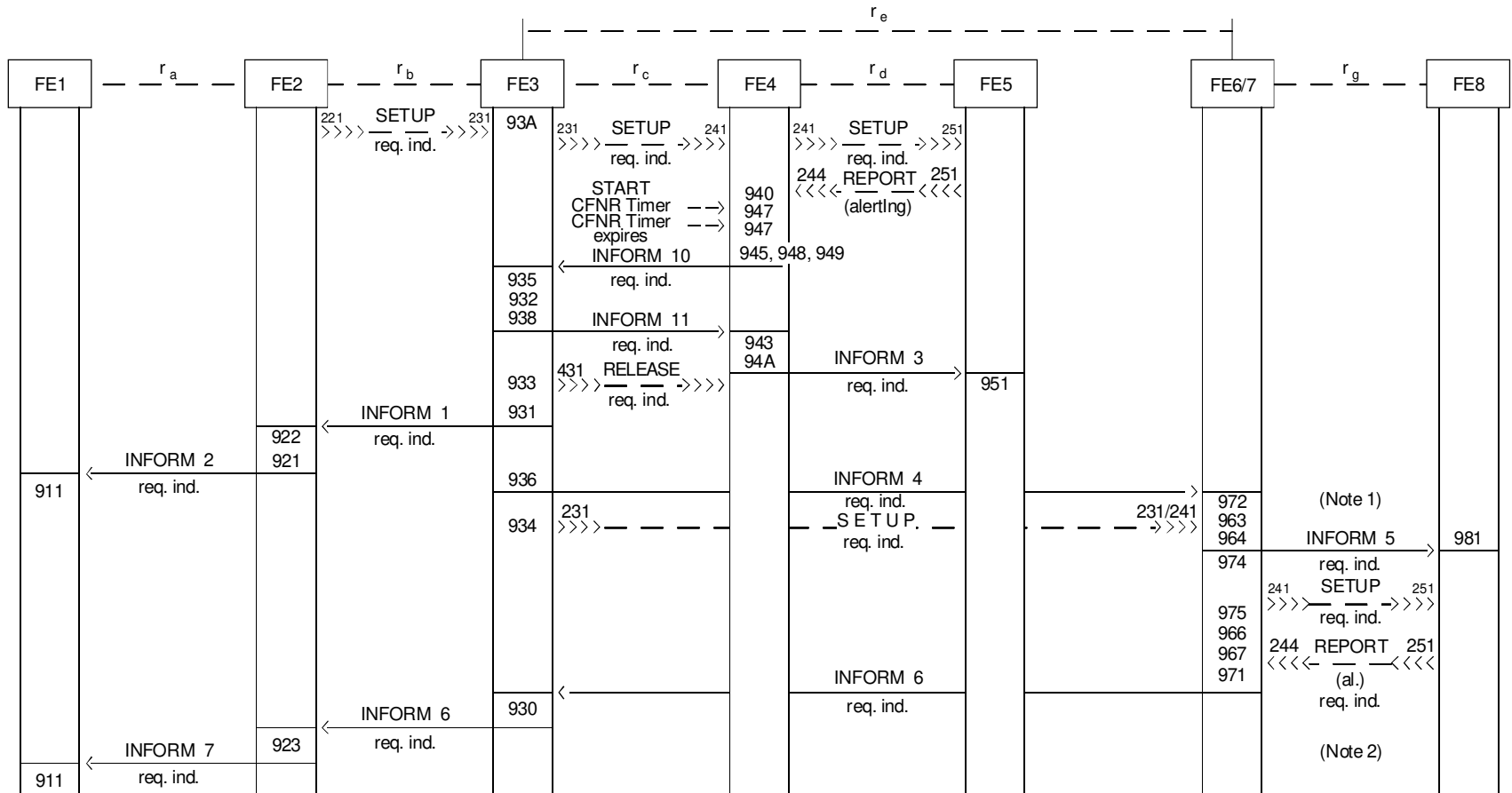

T1144140-92/d07

NOTE – The notes are found after Figure 2-12.

FIGURE 2-7/Q.82
CFNR, Option B, early release

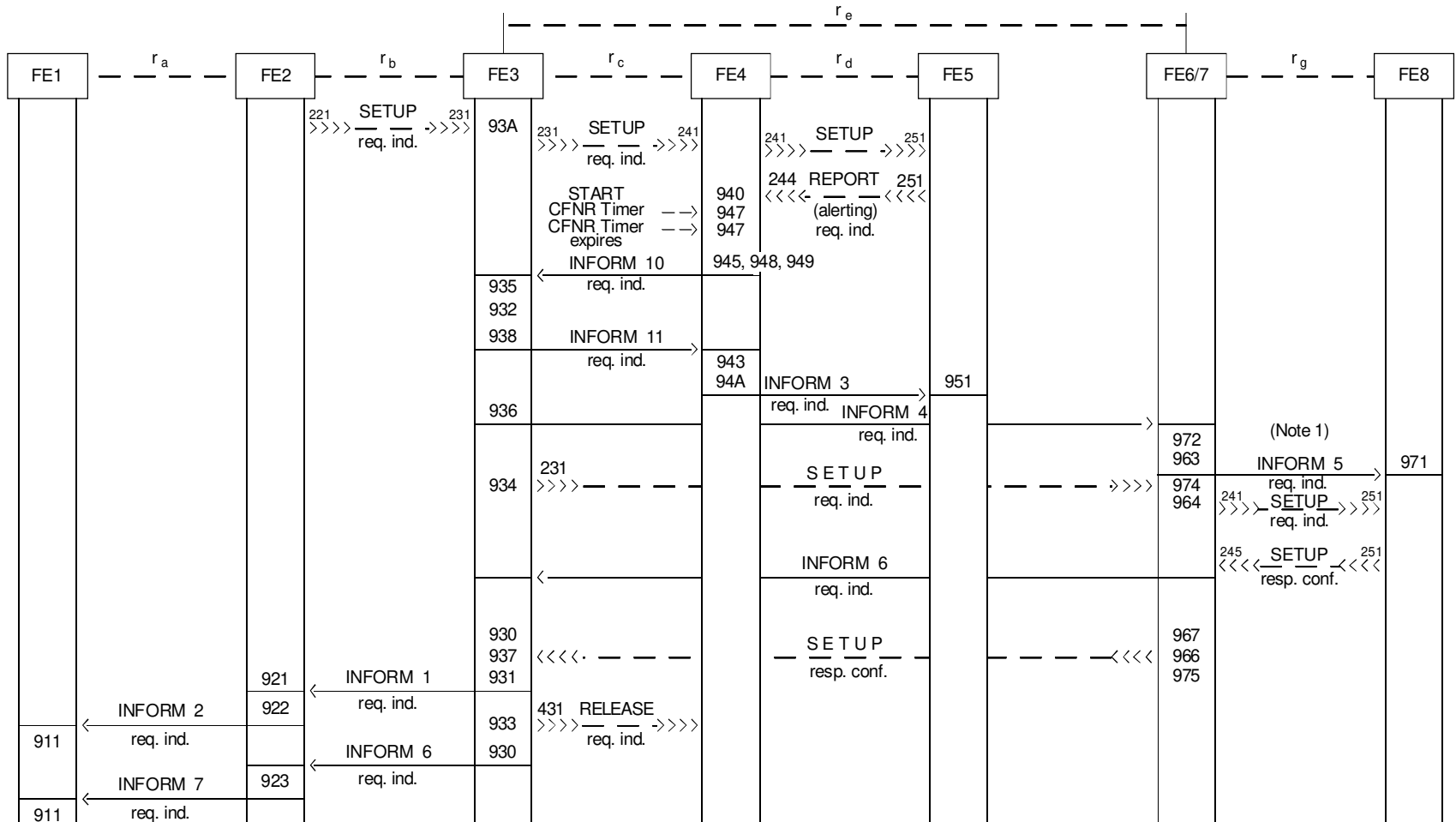

T1 144150-92/d08

NOTE – The notes are found after Figure 2-12.

FIGURE 2-8/Q.82
CFNR, Option A, late release, C has automatic answering equipment

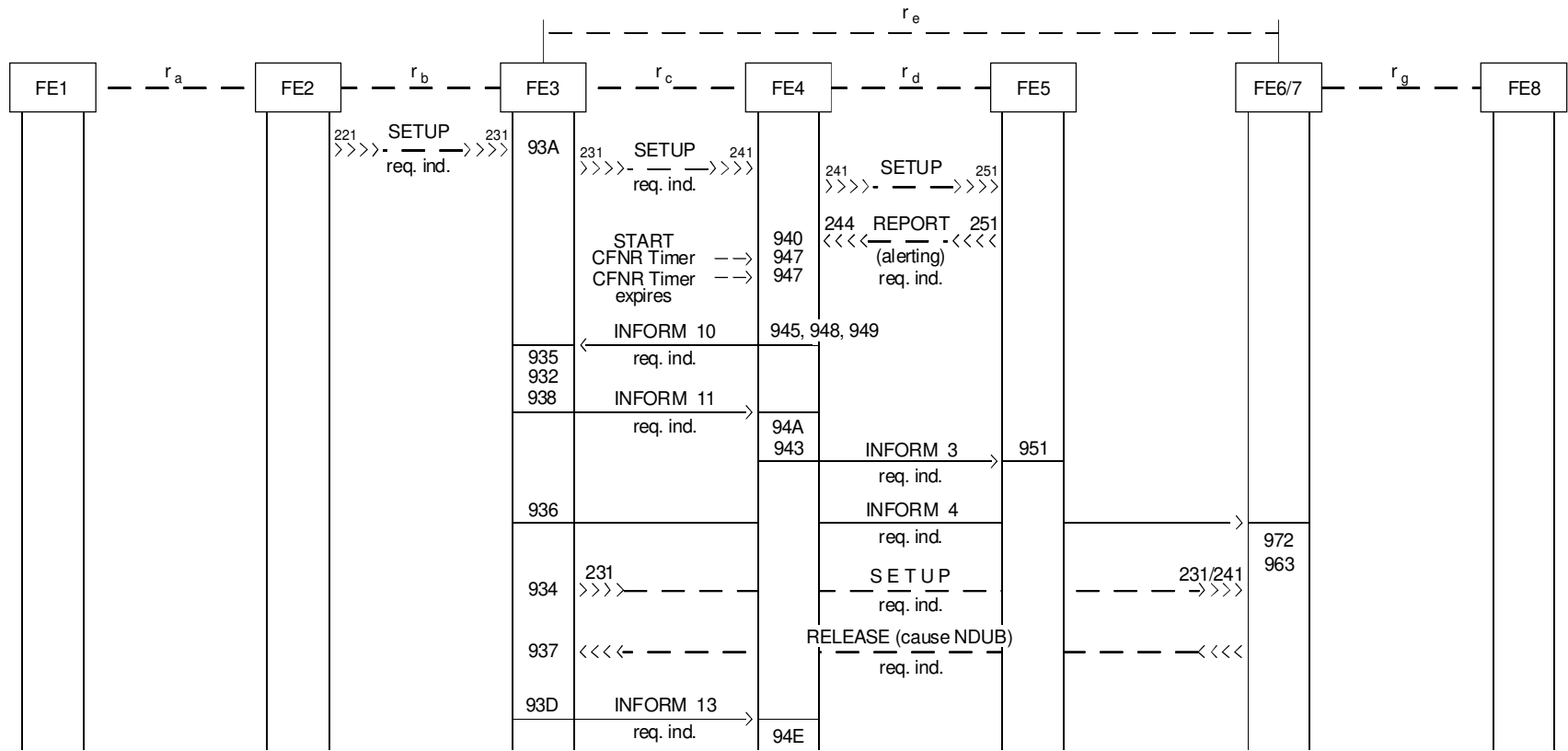

T1144160-92/d09

(Note 3)

NOTE – The notes are found after Figure 2-12.

FIGURE 2-9/Q.82
CFNR, Option A, late release, C-party NDUB

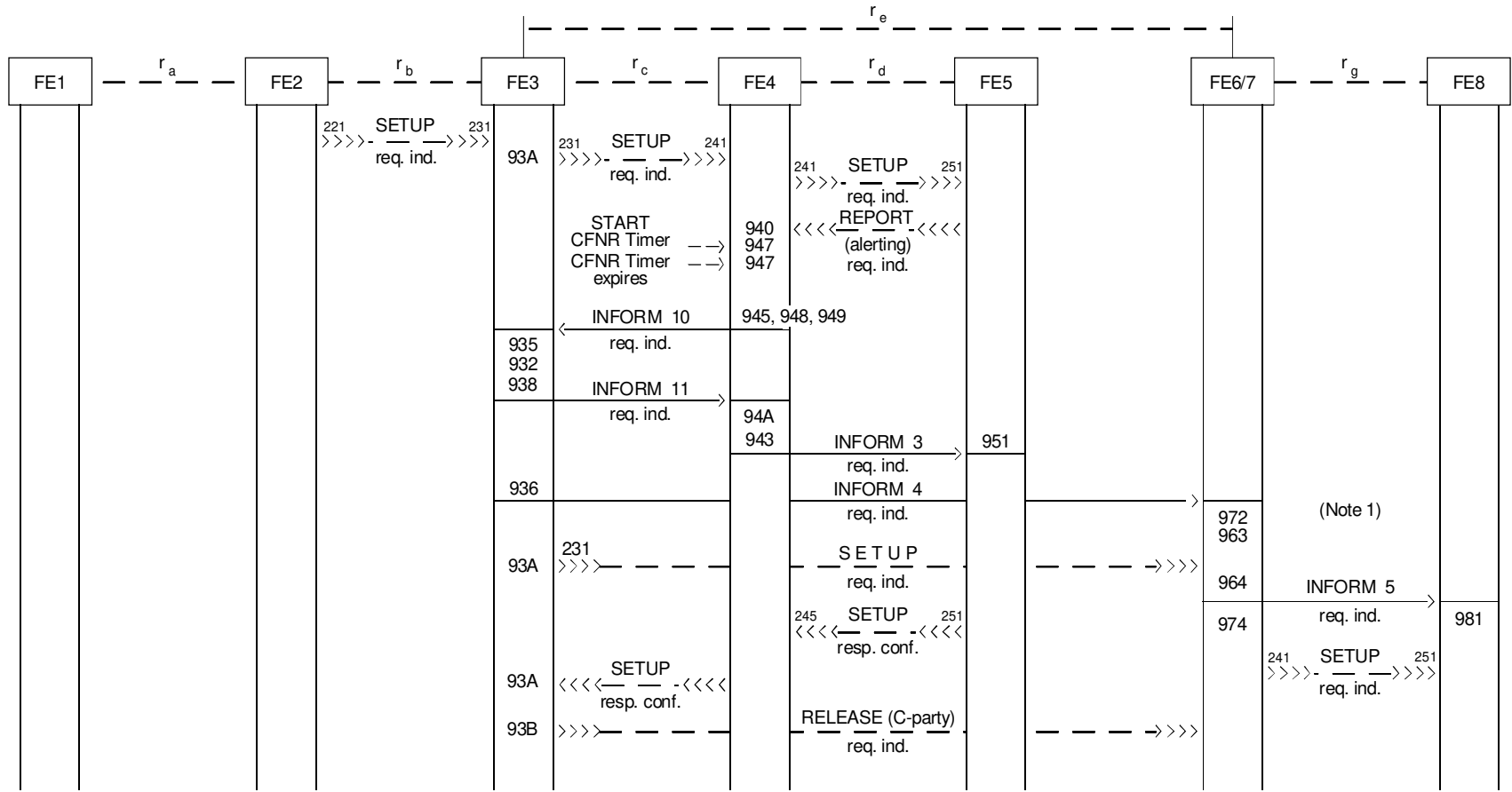

T1144170-92/d10

NOTE – The notes are found after Figure 2-12.

FIGURE 2-10/Q.82
CFNR, Option A, late release, B-party answers before receipt of alerting of the C-party

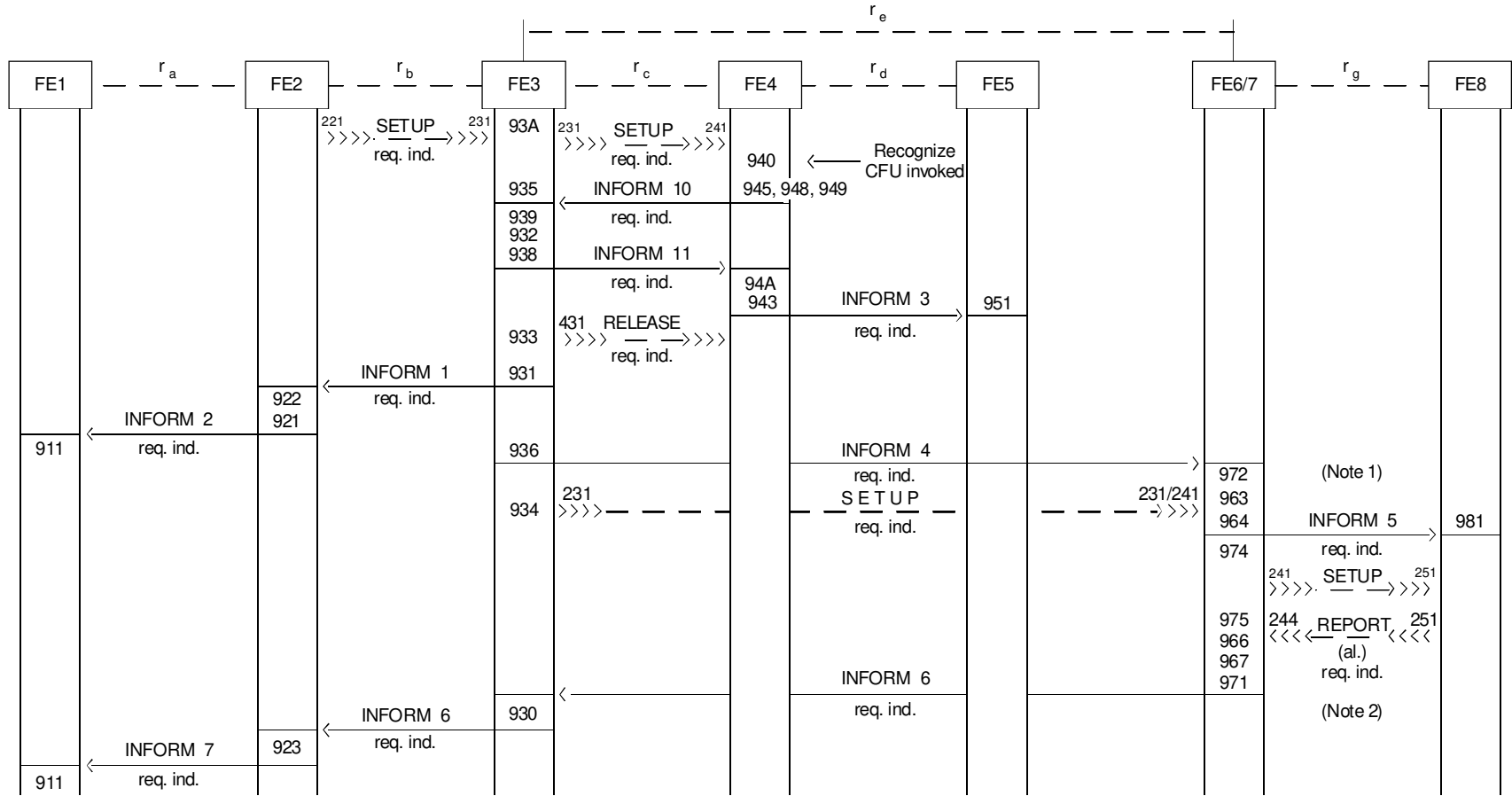

T1 144180-92/d11

NOTE – The notes are found after Figure 2-12.

FIGURE 2-11/Q.82
Information flow for CFU

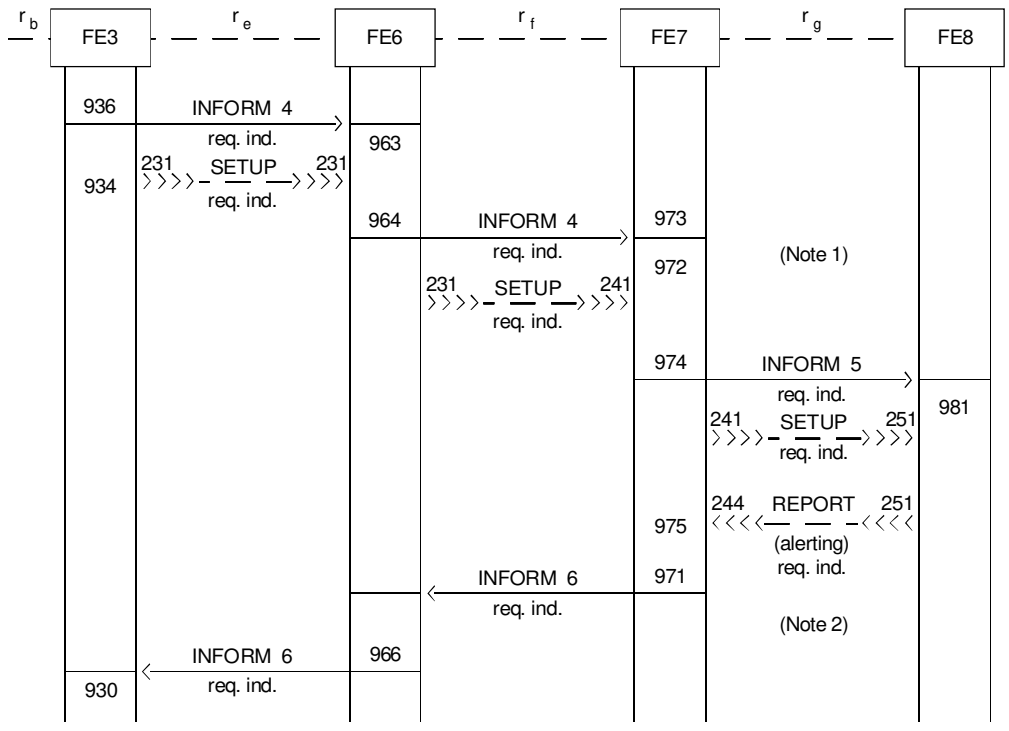

T1144190-92/d12

FIGURE 2-12/Q.82

Flows across the public/private network interface at C-party

NOTES related to the Figures 2-4 to 2-12:

- 1 The INFORM 5 shall be presented to FE8 not later than the associated SETUP req. ind.
- 2 In case of:
 - COLR temporary mode activated at C; or
 - immediately responding terminal at C,
 the PI-value will be determined on receipt of SETUP resp. conf from FE8.
- 3 The information flow "INFORM 13" is optional; i.e. only required with the option to restart the CFNR timer.

2.7.2 Definition of individual information flows

Relationship r_a

INFORM 2 (Notes 2 and 8)

The contents of INFORM 2 are shown in Table 2-1.

TABLE 2-1/Q.82

Parameter	Allowed value	req.ind.
Forwarding indicator		M

INFORM 7 (Notes 3 and 8)

The contents of INFORM 7 are shown in Table 2-2.

TABLE 2-2/Q.82

Parameter	Allowed value	req.ind.
Forwarded-to number	- ISDN number - Number restricted - Number not available	M

Relationship r_b

INFORM 1 (Note 8)

The contents of INFORM 1 are shown in Table 2-3.

TABLE 2-3/Q.82

Parameter	Allowed value	req.ind.
Forwarding indicator (FI) including notification subscription option	No Yes, without FTN Yes, with FTN	M
Forwarding cause	CFU, CFB, CFNR	M
Forwarded-to number FTN (Note)		O

NOTE – This option refers to the situation in which the forwarded-to number is withheld on the basis of a network provider decision.

INFORM 6 (Note 8)

The contents of INFORM 6 are shown in Table 2-4.

TABLE 2-4/Q.82

Parameter	Allowed value	req.ind.
Presentation indicator	Presentation allowed Presentation not allowed	M

Relationship r_c

Contents of INFORM 10 (rerouting request)

NOTE – All the information necessary to FE3 to launch the forwarded call shall be included in the INFORM 10.

The contents of INFORM 10 are shown in Table 2-5.

TABLE 2-5/Q.82

Parameter	Allowed value	req.ind.
Cause for forwarding (CFU)		M
Called party address (incl. FTN)		M
Forwarding indicator		M
Forwarding number		O
Restriction indicator for forwarding number		M
Telecommunication service information		M
User-to-user information		O
Forwarding counter		M
Calling party sub-address		O
Network facility indicator (NFI)		O

INFORM 11

The contents of INFORM 11 are shown in Table 2-6.

TABLE 2-6/Q.82

Parameter	Allowed value	req.ind.
Forwarding invocation result	Positive/negative acknowledgment	M

INFORM 13

There is no content of INFORM 13.

Relationship r_d

INFORM 3

The contents of INFORM 3 are shown in Table 2-7.

TABLE 2-7/Q.82

Parameter	Allowed value	req.ind.
Served user's address ^{a)}		M
User-to-user information (if available) ^{a)}		M
Forwarding cause		M
Telecommunication service information ^{a)}		M
Calling party address (Note 1) ^{a)}		O
Last forwarding number (Note 7) ^{a)}		M (Note)
Cause for last forwarding ^{a)}		M (Note)
Originally called number (Note 7) ^{a)}		M (Note)
Cause for original forwarding ^{a)}		M (Note)
^{a)} Parameter not required in case of CFNR and CFB (UDUB). NOTE – Only applicable in case of multiple forwarding.		

INFORM 12

The contents of INFORM 12 are shown in Table 2-8.

TABLE 2-8/Q.82

Parameter	Allowed value	req.ind.
CF invocation result	Negative acknowledgement	M
Served user's address		M
Telecommunication service information		M

Relationship r_e

INFORM 4

The contents of INFORM 4 are shown in Table 2-9.

TABLE 2-9/Q.82

Parameter	Allowed value	req.ind.
Forwarding cause		M
Forwarding number (Note 6)		M
Forwarding counter		M
Original called number (Note 6)		M

INFORM 6 (Notes 5 and 8)

The contents of INFORM 6 are shown in Table 2-10.

TABLE 2-10/Q.82

Parameter	Allowed value	req.ind.
Presentation indicator for FTN	Presentation allowed Presentation not allowed	M ^{a)}
a) Mandatory in case of presentation allowed.		

Relationship r_f

INFORM 4

The contents of INFORM 4 are shown in Table 2-11.

TABLE 2-11/Q.82

Parameter	Allowed value	req.ind.
Forwarding cause		M
Forwarding number (Note 6)		M
Forwarding counter		M
Originally called number (Note 6)		M

INFORM 6 (Notes 5 and 8)

The contents of INFORM 6 are shown in Table 2-12.

TABLE 2-12/Q.82

Parameter	Allowed value	req.ind.
Presentation indicator for FTN	Presentation allowed Presentation not allowed	M ^{a)}
a) Mandatory in case of presentation allowed.		

Relationship r_g

INFORM 5

The contents of INFORM 5 are shown in Table 2-13.

TABLE 2-13/Q.82

Parameter	Allowed value	req.ind.
Last forwarding cause		M
Last forwarding number (Note 7)		O
Originally called number (Note 7)		O
Calling party address (Note 1)		O

NOTES related to this subclause (2.7.2) and the tables:

1 The calling party number shall be included if required by the “calling line identification presentation supplementary service”, if not restricted.

2 The INFORM 2 shall be sent only if the B-party has subscribed to the subscription option “calling user receives notification his call has been forwarded”.

3 The INFORM 7 shall be sent to FE1 only if the B-party has subscribed to the additional option that notification can include the forwarded-to number and if the C-party has not invoked to COLR.

4 The INFORM 3 is a subscription option. It also contains all information necessary to identify the served user, e.g. the served user’s number including all DDI-Digits.

In case of CFB (UDUB) and CFNR some of the parameters are part of the call offering information.

5 The INFORM 6 shall be sent after it has been determined that COLR will not be invoked, i.e. in case of

- COLR perm. mode not subscribed to;
- COLR temp. mode not subscribed to; and
- COLR temp. mode subscribed but not activated when alerting commences;

in case of COLR temporary mode activated on answer.

6 This number will always be transferred in the network together with a “restriction indicator” whose value is set according to the subscription options of the user.

On boundaries between different networks or to private networks the number might not be passed depending on a network provider decision.

7 This number shall only be included if no restrictions exist.

8 Notification of diversion of the calling user may be provided as a network provider option. If provided by the network, the network shall support the functional entity actions/information flows necessary for the “calling user receives notification that his call has been diverted” subscription option.

If not provided by the network, the network will not support the functional entity actions/information flows necessary for the “calling user receives notification that his call has been diverted” subscription option.

2.8 SDL diagrams for functional entities

Notification of diversion of the calling user may be provided as a network provider option. If provided by the network, the network shall support the functional entity actions/information flows necessary for the “calling user receives notification that his call has been diverted” subscription option.

If not provided by the network, the network will not support the functional entity actions/information flows necessary for the “calling user receives notification that his call has been diverted” subscription option.

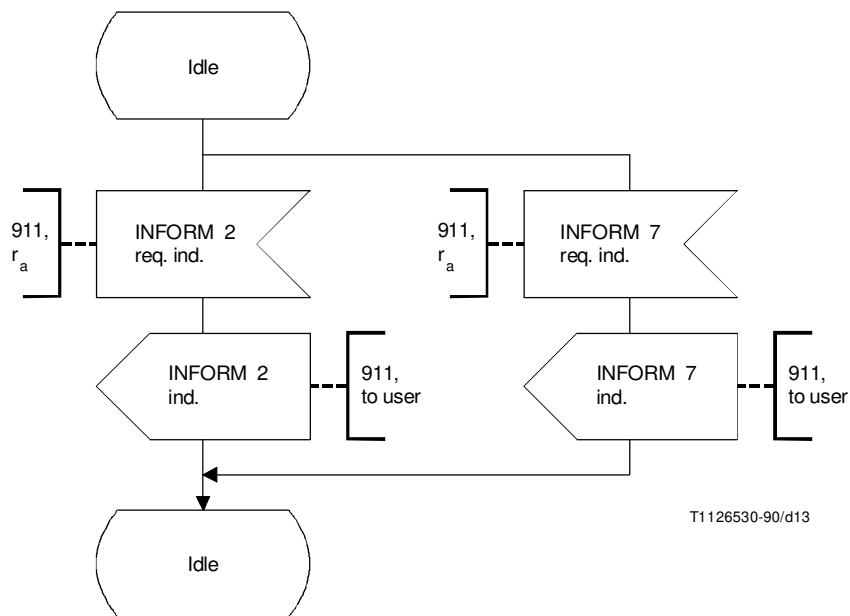
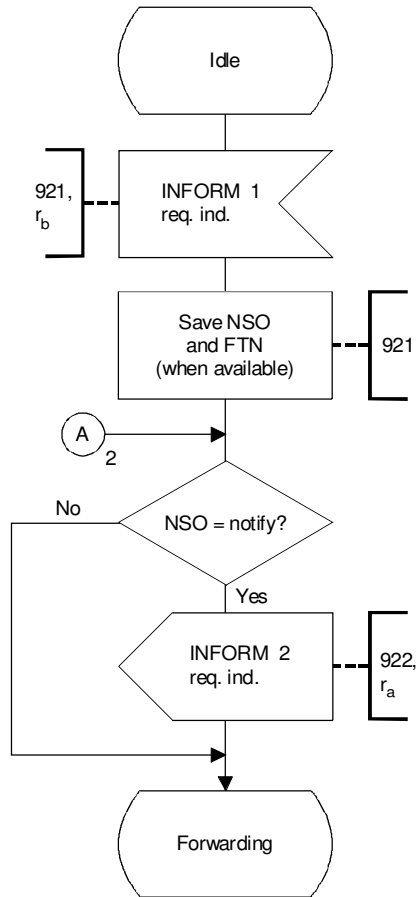

FIGURE 2-13/Q.82

FE1. Call Diversion



T1 126540-90/d14

FIGURE 2-14/Q.82 (sheet 1 of 2)

FE2. Call Diversion

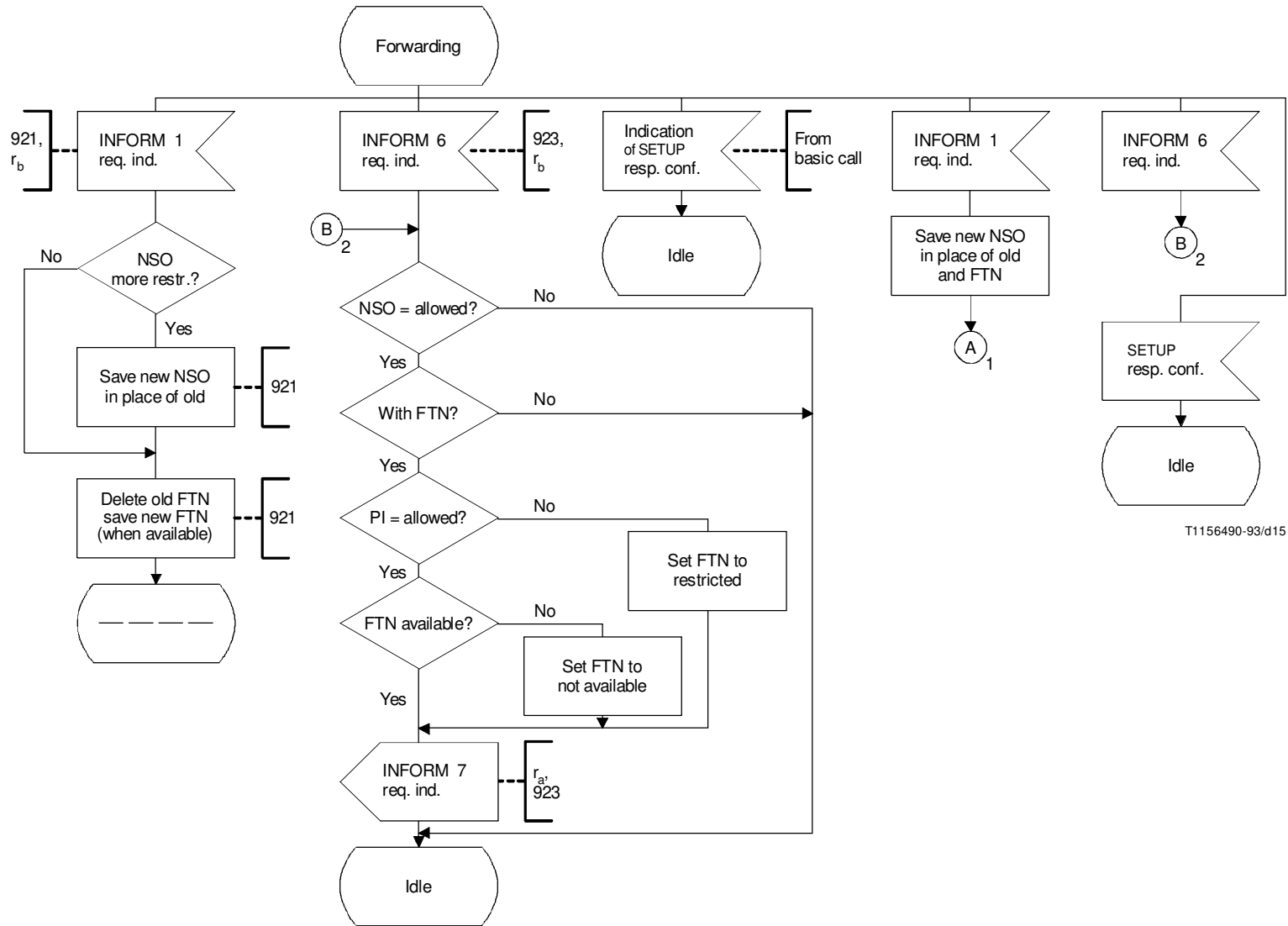

T1156490-93/d15

FIGURE 2-14/Q.82 (sheet 2 of 2)
FE2. Call Diversion

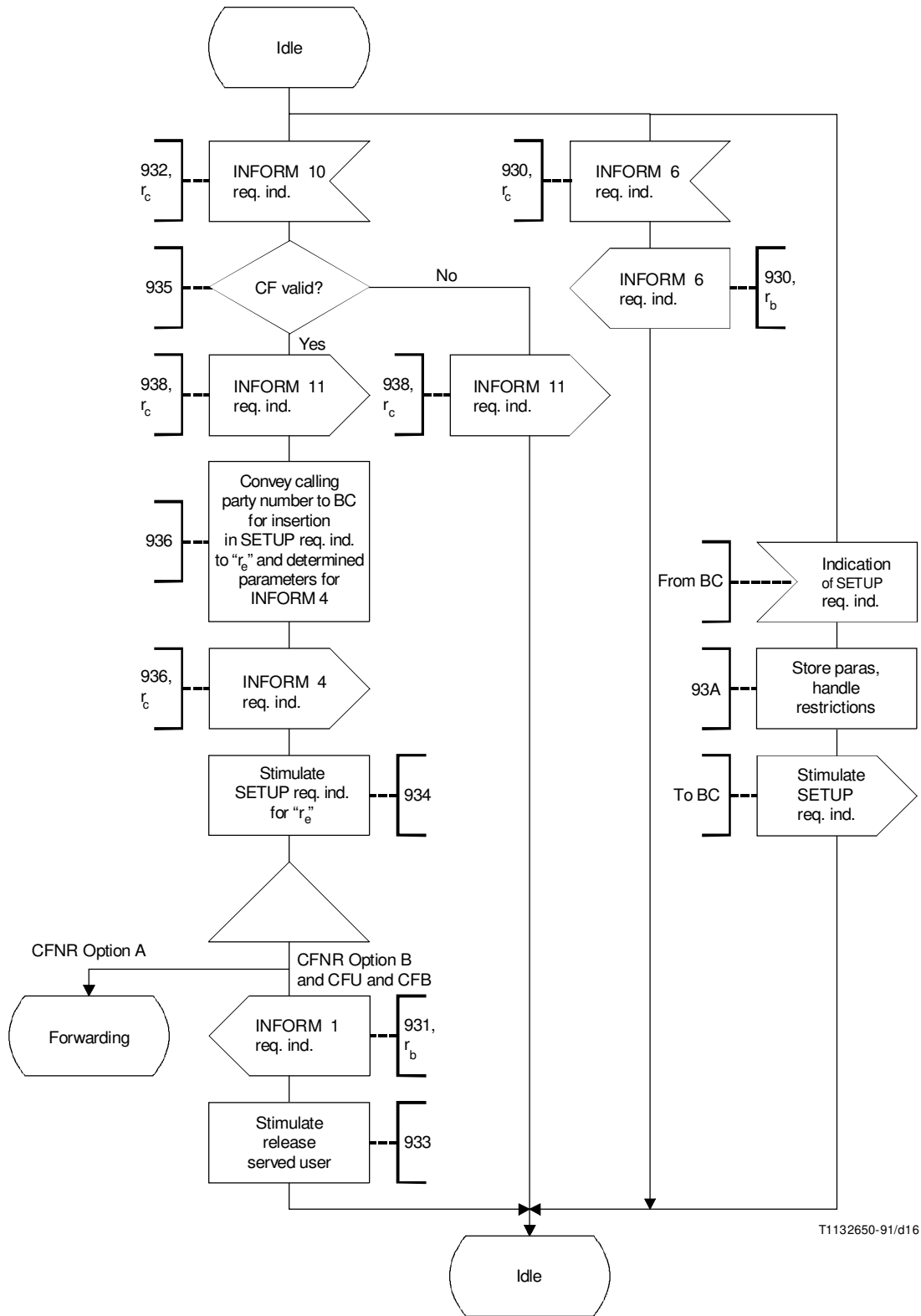

T1132650-91/d16

FIGURE 2-15/Q.82
FE3. Call Forwarding

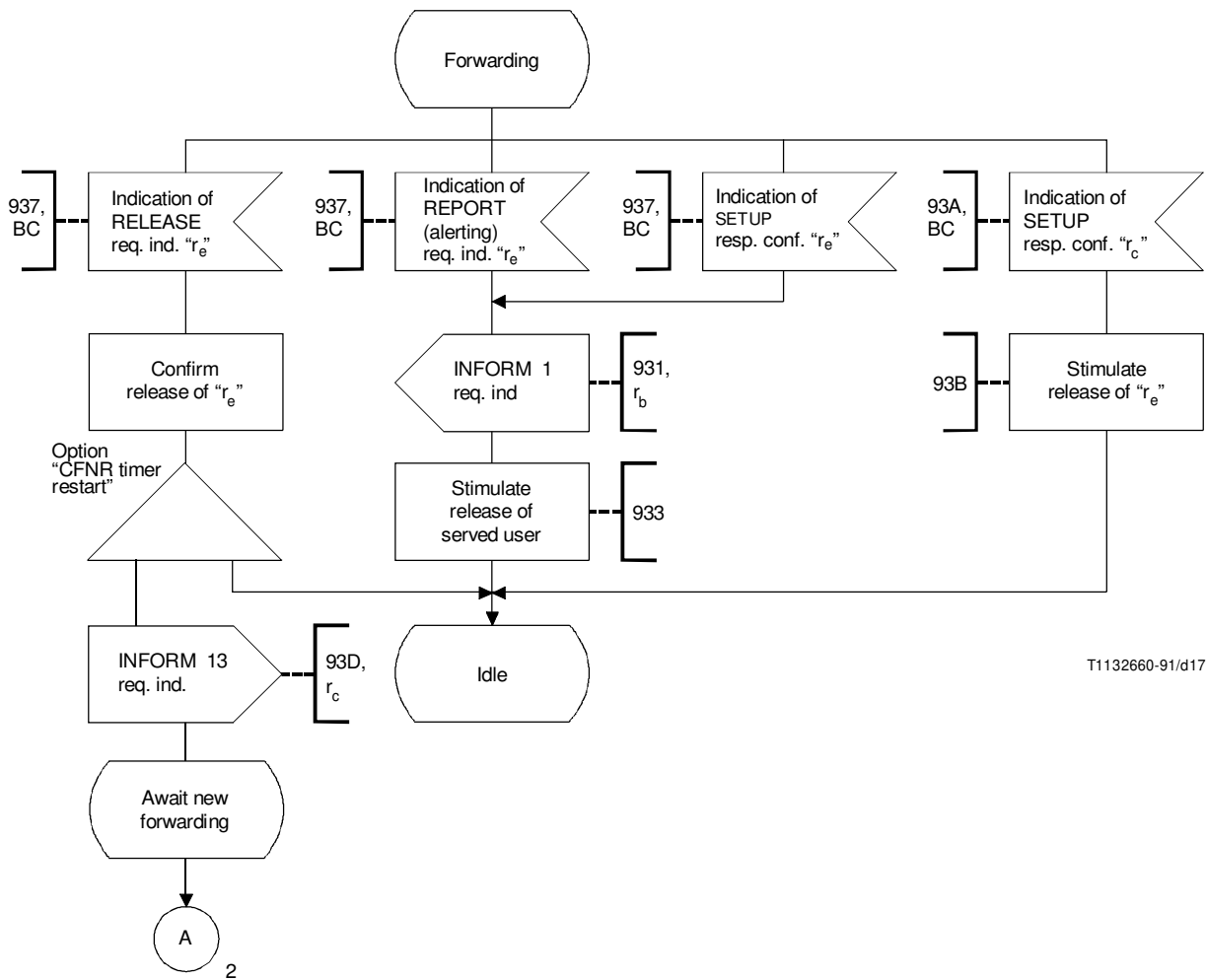

T1132660-91/d17

FIGURE 2-16/Q.82 (sheet 1 of 2)

FE3. Call Forwarding

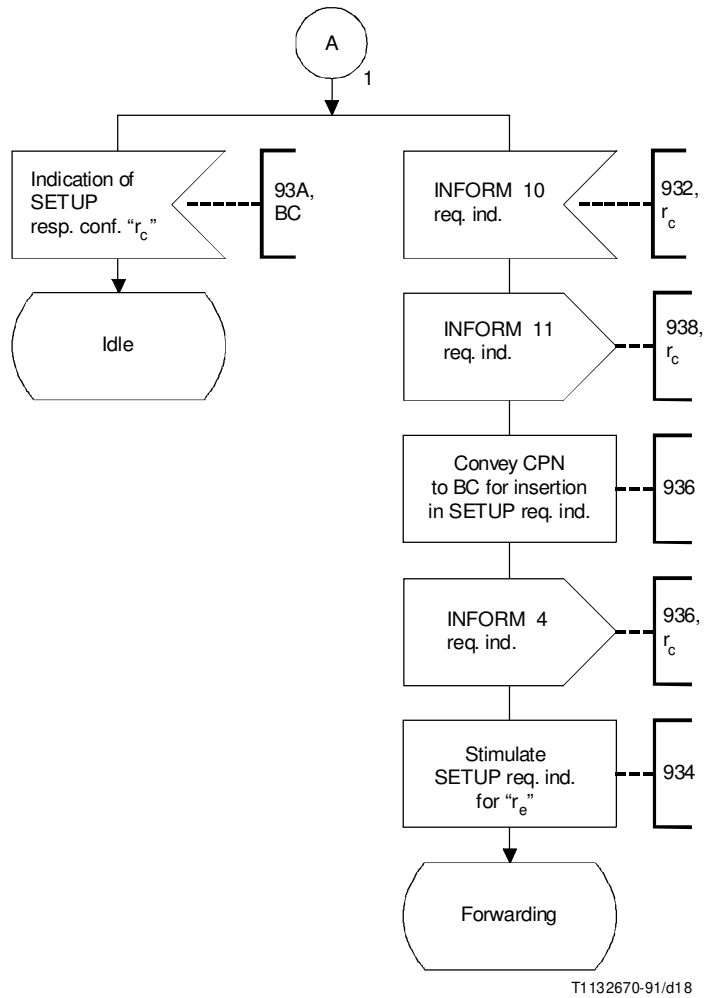
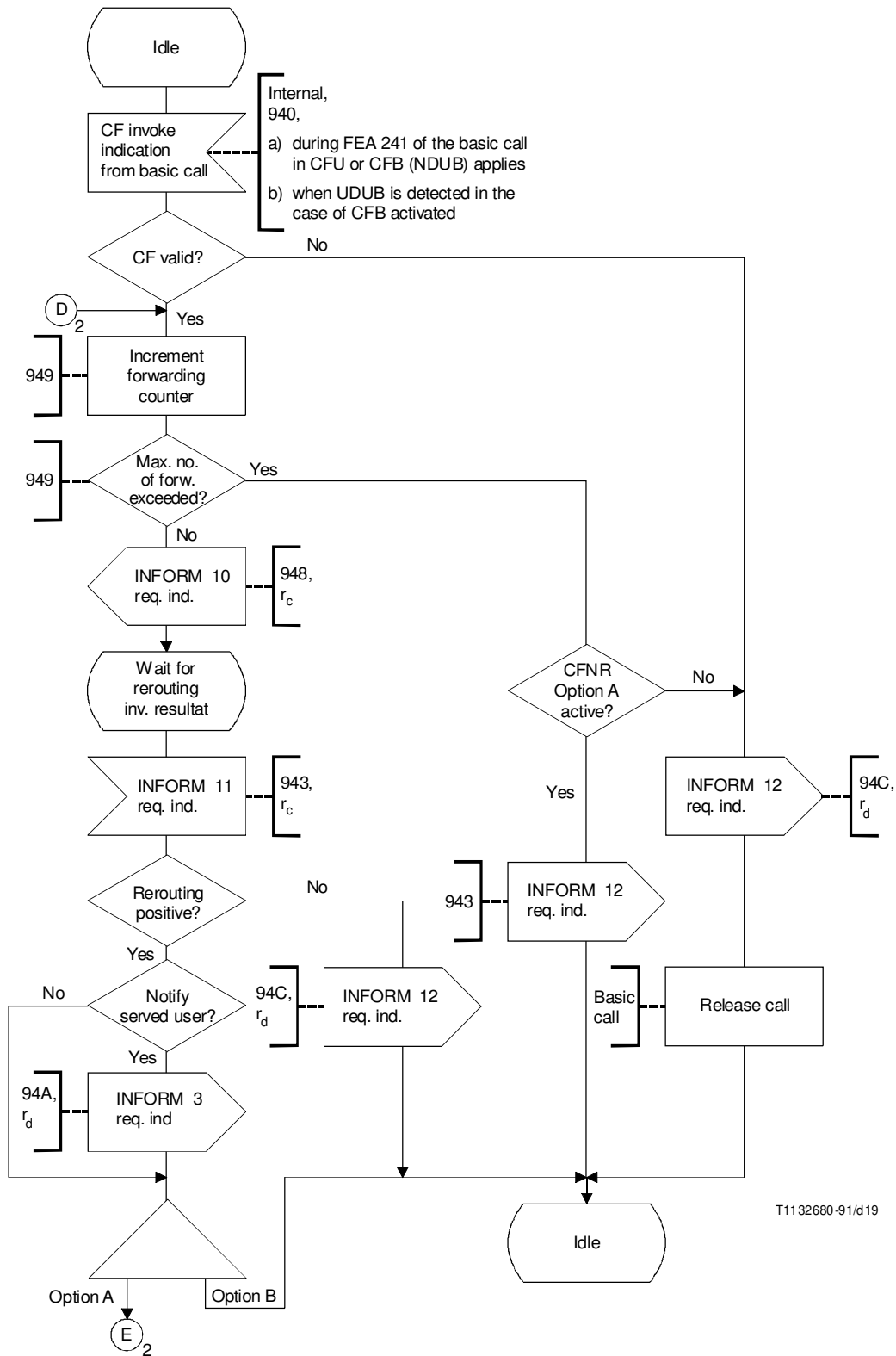

FIGURE 2-16/Q.82 (sheet 2 of 2)

FE3. Call Forwarding



T1132680-91/d19

FIGURE 2-17/Q.82 (sheet 1 of 2)

FE4. Call Forwarding

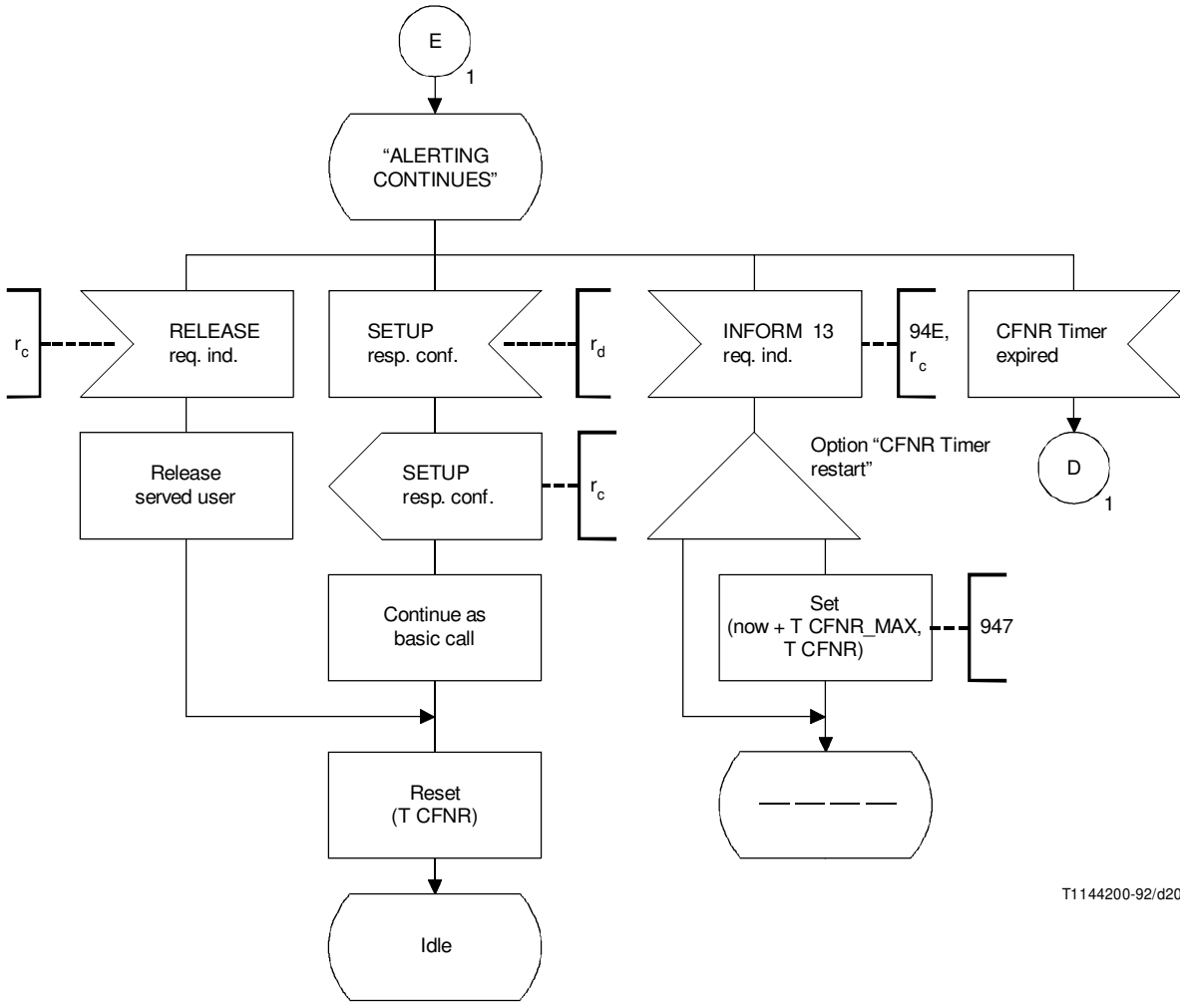

T1144200-92/d20

FIGURE 2-17/Q.82 (sheet 2 of 2)

FE4. Call Forwarding

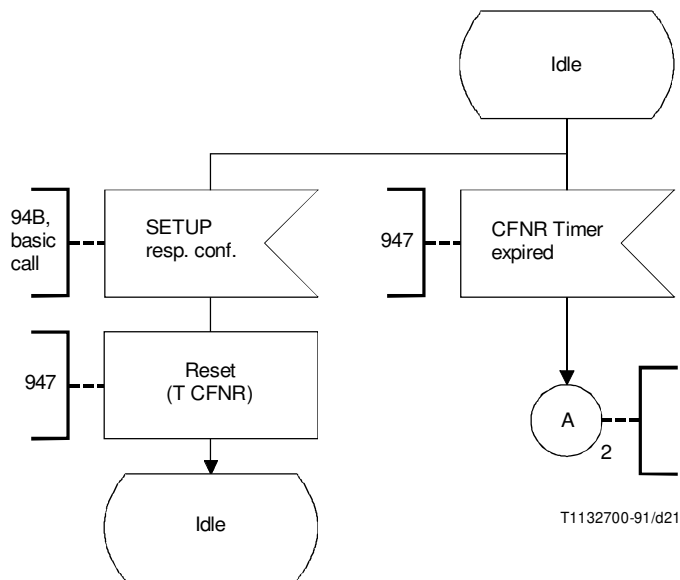
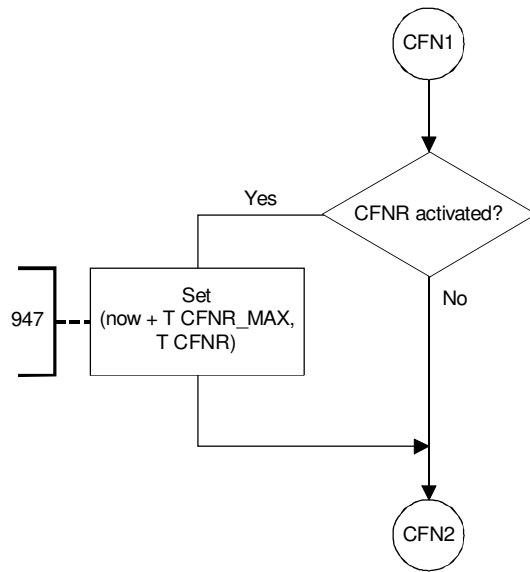

T1132700-91/d21

NOTE – CFN1 and CFN2 break the basic call, Recommendation Q.71 [4], between Connectors S4/27 and S4/28.

FIGURE 2-18/Q.82 (sheet 1 of 2)

FE4. Call Forwarding No Reply

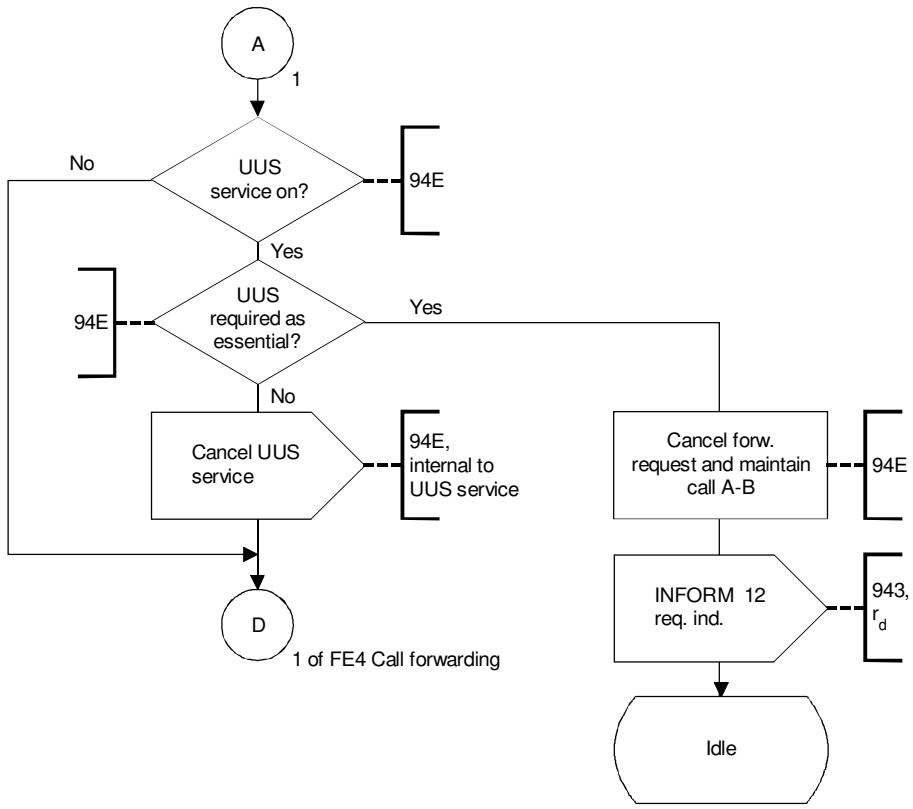

T1132710-91/d22

FIGURE 2-18/Q.82 (sheet 2 of 2)
FE4. Call Forwarding No Reply

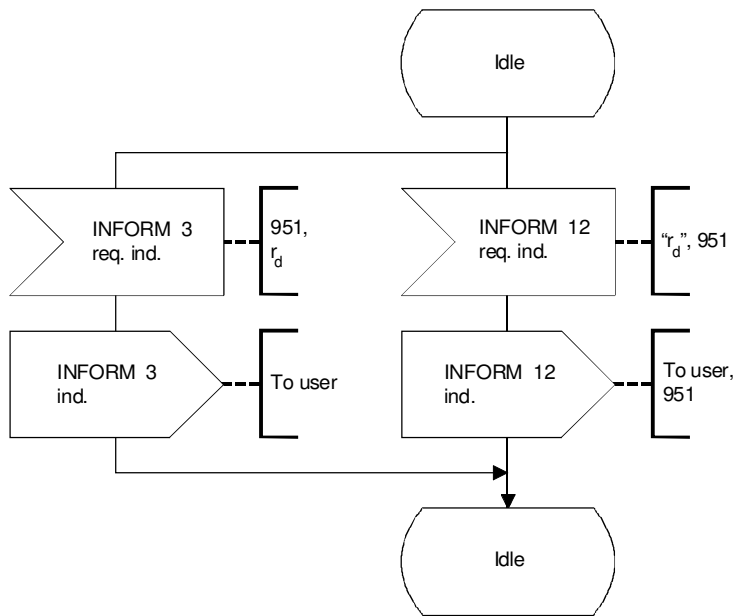

T1 126620-90/d23

FIGURE 2-19/Q.82
FE5. Call Forwarding

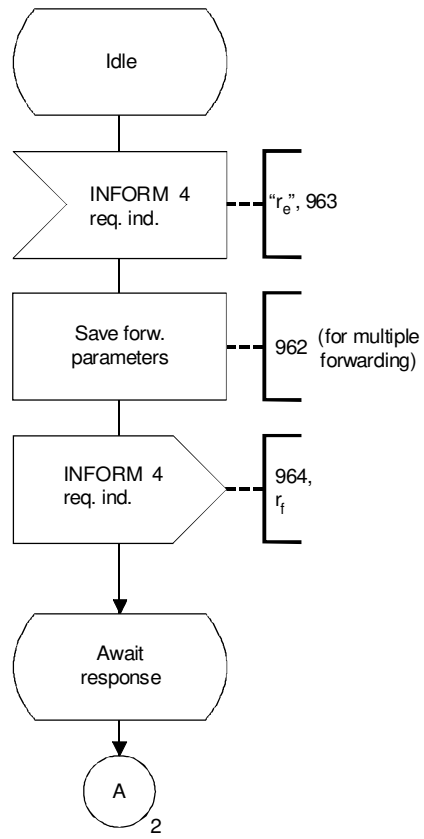

T1132730-91/d24

FIGURE 2-20/Q.82 (sheet 1 of 3)
FE6. Call Forwarding

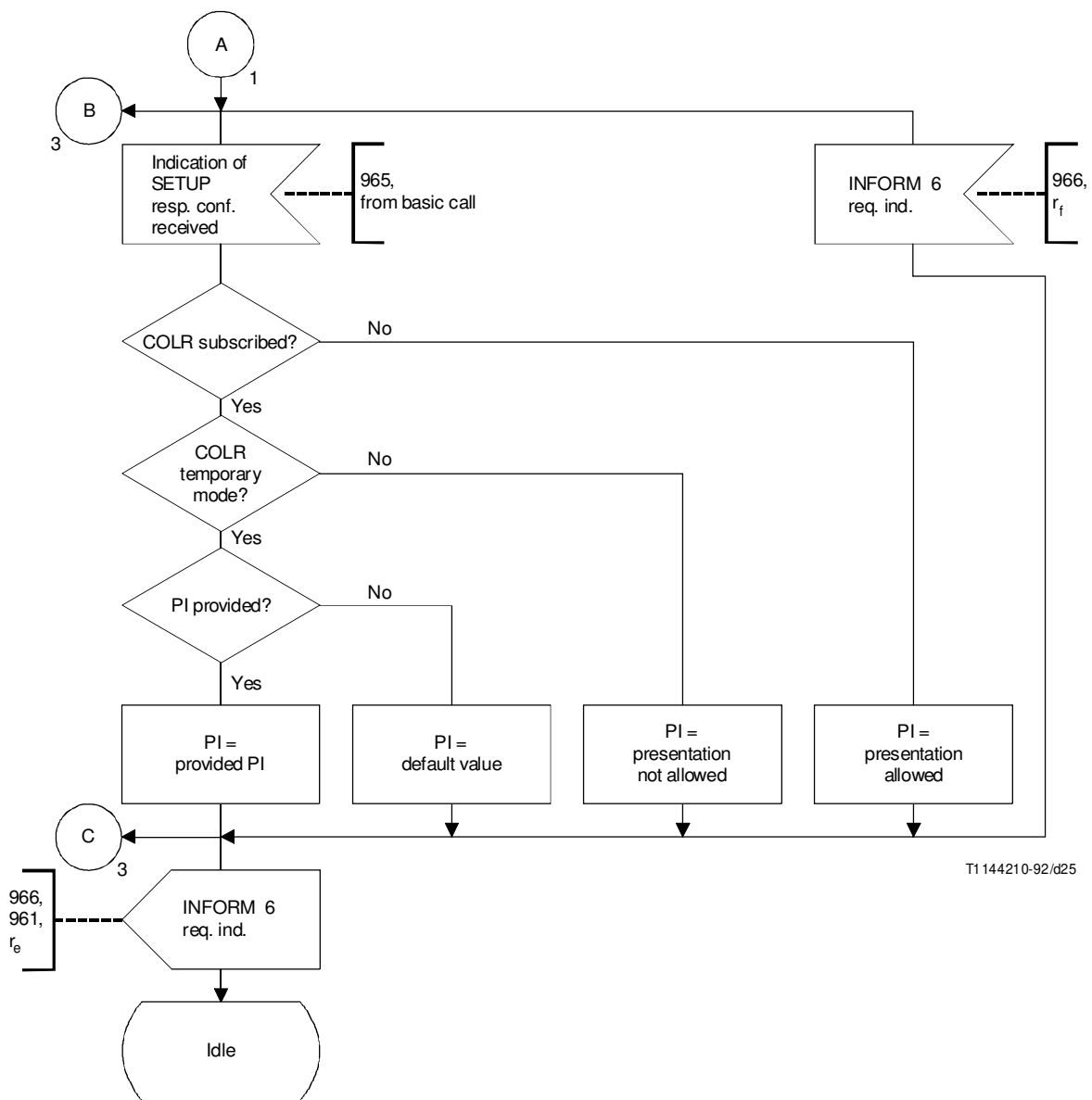

T1 144210-92/d25

FIGURE 2-20/Q.82 (sheet 2 of 3)

FE6. Call Forwarding

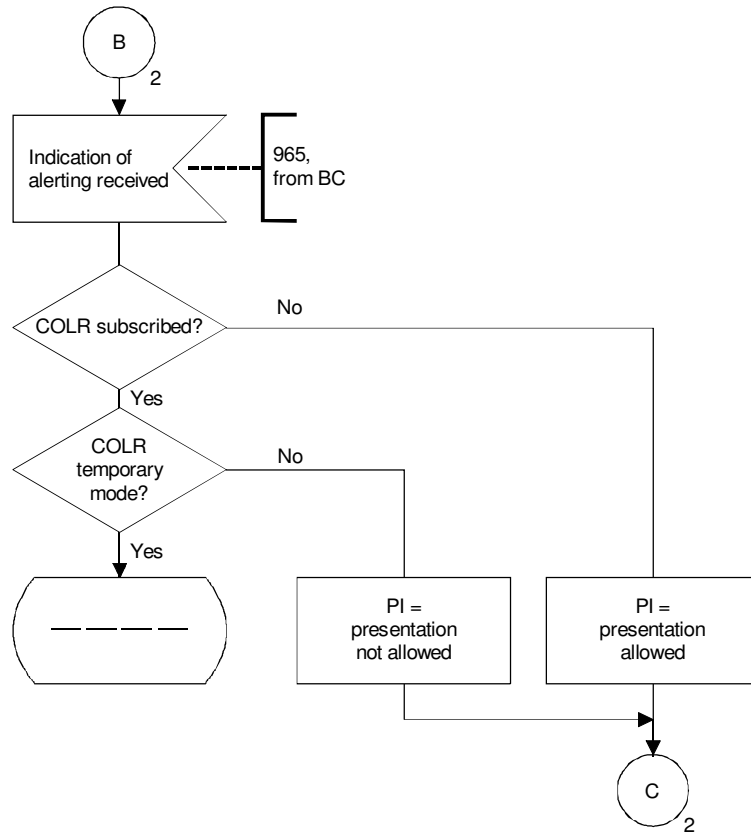

T1132750-91/d26

NOTE – The PI shall be determined by considering the interactions with COLR Supplementary Service and the Basic Service.

FIGURE 2-20/Q.82 (sheet 3 of 3)

FE6. Call Forwarding

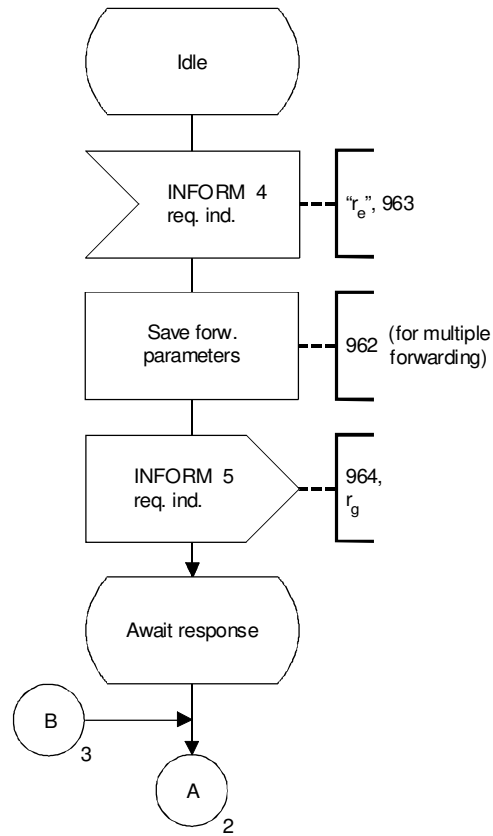

T1132760-91/d27

FIGURE 2-21/Q.82 (sheet 1 of 3)
FE7. Call Forwarding

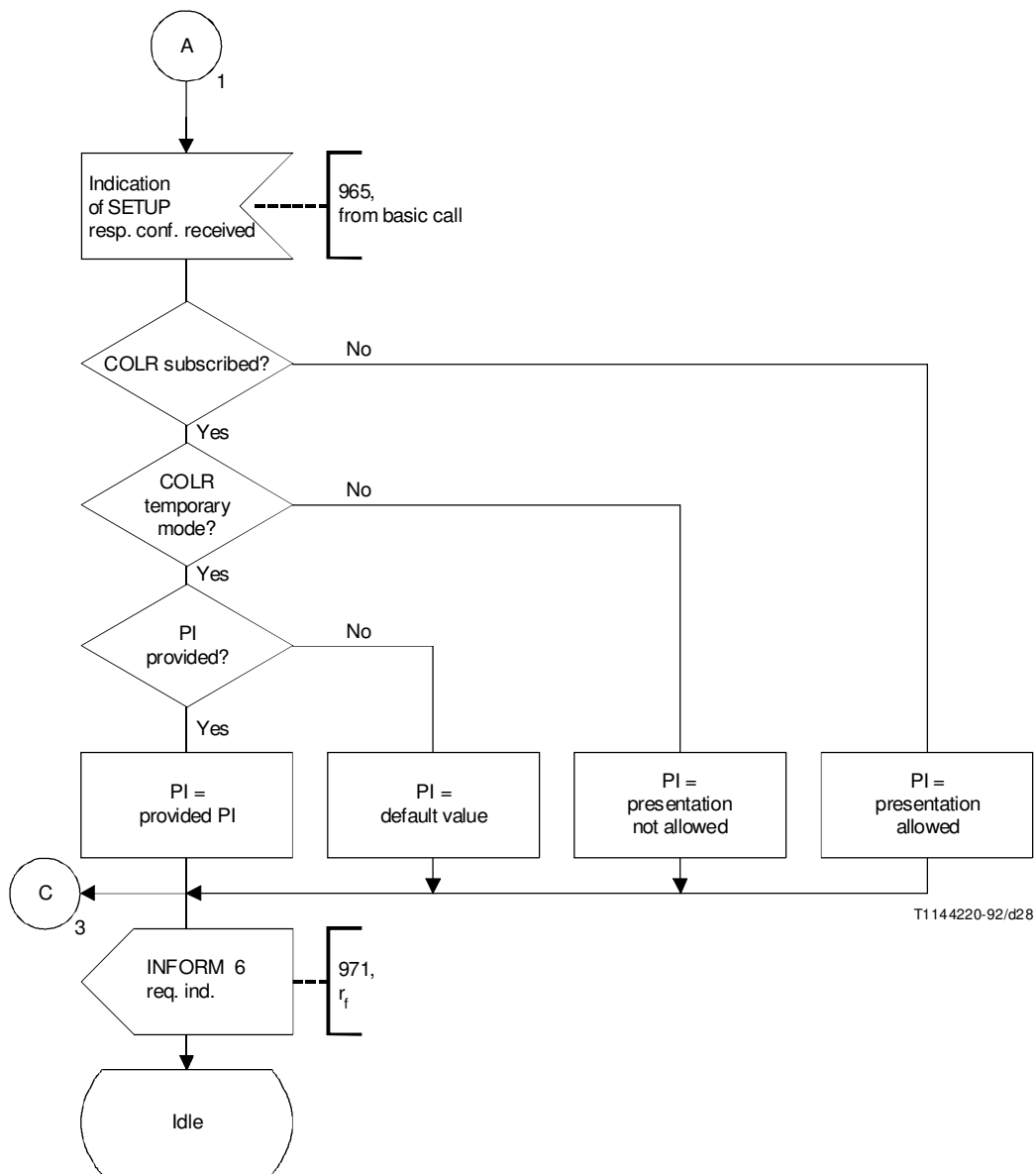

T1144220-92/d28

FIGURE 2-21/Q.82 (sheet 2 of 3)

FE7. Call Forwarding

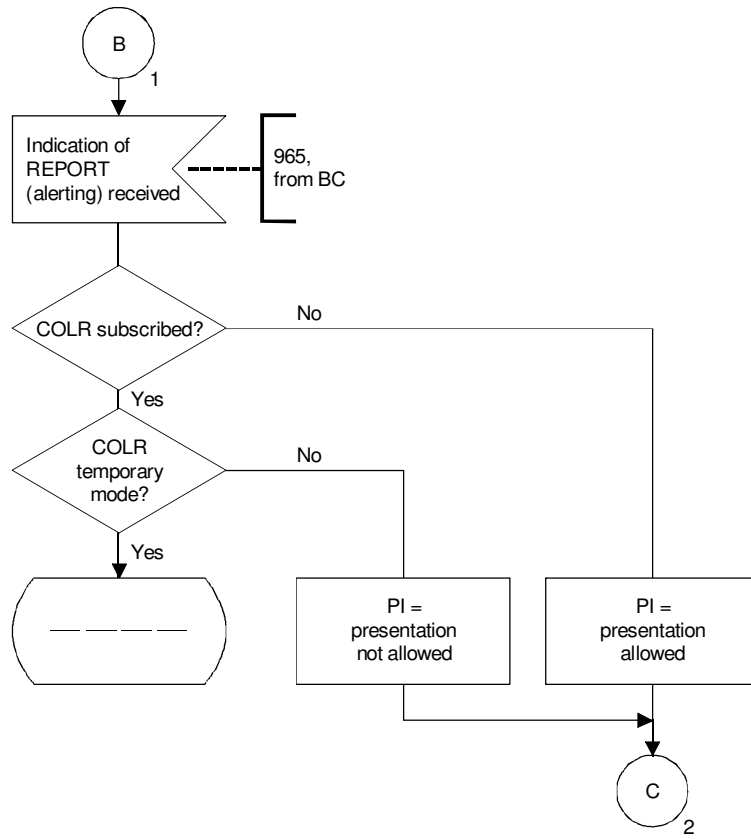

T1132780-91/d29

NOTE – The PI shall be determined by considering the interactions with COLR Supplementary Service and the Basic Service.

FIGURE 2-21/Q.82 (sheet 3 of 3)

FE7. Call Forwarding

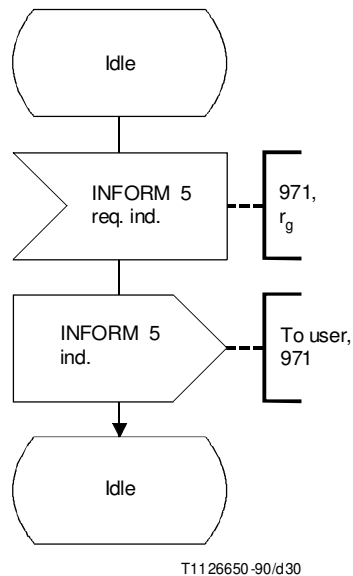

FIGURE 2-22/Q.82
FE7. Call Diversion

2.9 Functional entity actions

In the following subclauses the actions specific for the supplementary service Call Forwarding at the different functional entities are described.

Notification of diversion of the calling user may be provided as a network provider option. If provided by the network, the network shall support the functional entity actions/information flows necessary for the “calling user receives notification that his call has been diverted” subscription option.

If not provided by the network, the network will not support the functional entity actions/information flows necessary for the “calling user receives notification that his call has been diverted” subscription option.

2.9.1 Functional Entity Actions for FE1

911: Receive indications related to the service from FE2 and present them to the calling user.

2.9.2 Functional Entity Actions for FE2

921: Receive INFORM 1;

Delete old FTN if already saved;

Save new FTN (when available);

Save NSO, if it is the first or a subsequent more restrictive NSO.

922: Send INFORM 2 to FE1 if allowed.

923: Receive INFORM 6 and send INFORM 7 to FE1 if allowed.

2.9.3 Functional Entity Actions for FE3

931: Send INFORM 1 to FE2.

932: Receive INFORM 10 (forwarding request) including all necessary parameters from FE4.

- 933: Stimulate release procedures for the leg towards the served user.
- 934: Stimulate basic call set-up towards the forwarded-to user.
- 935: Decide whether forwarding is allowed and valid.
- 936: Insert stored parameters (FEA 93A) into INFORM 4 req.ind or SETUP req.ind towards the forwarded-to user and send them with all necessary information to FE6.
- 937: Receive indication from the Basic Call of REPORT (alerting), SETUP resp.conf. or RELEASE req.ind. detected on the leg towards the forwarded-to user.
- 938: Send INFORM 11 (result of forwarding request) to FE4.
- 930: Receive INFORM 6 from FE6 and send it to FE2.
- 93A: Receive indication of SETUP req.ind. from Basic Call and store calling party number and restriction indicator.
- 93B: Stimulate release of the leg towards the forwarded-to user.
- 93C: Receive indication from the Basic Call of SETUP resp.conf. detected on the leg towards the served user after the forwarding attempt has started (served user answers the call).
- 93D: Send INFORM 13 to FE4.

2.9.4 Functional Entity Actions for FE4

- 941:
- 942:
- 943: Receive INFORM 11 and, if forwarding, request and determine the success or failure of the forwarding request.
- 945: Validation of Call Forwarding request.
- 946: Receive necessary parameters from FE6 (internal) in case of multiple forwarding (not described in the flows and SDLs).
- 947: Run periodic timers specific to the service.
- 948: Determine parameters for INFORM 10 and send INFORM 10 to FE3.
- 949: Increment forwarding counter and stimulate release procedure when the service call count limit is exceeded with the reason "Supplementary Service Incompatibility".
- 940: Recognize Call Forwarding invoked from Basic Service and retrieve necessary parameters in case of multiple forwarding.
- 94A: Send INFORM 3 to FE5 if required.
- 94B: Receive indication from the Basic Call of SETUP resp.conf. detected from the served user after the forwarding attempt has started (served user answers the call in case of CFNR).
- 94C: Send INFORM 12 to FE5.
- 94D: Inform Basic Call of CF invocation failure.
- 94E: Receive INFORM 13 from FE3.

2.9.5 Functional Entity Actions for FE5

- 951: Receive indications related to the served user from FE4 and present them to the served user.
- 952: (Deleted.)

2.9.6 Functional Entity Actions for FE6

- 961: Send INFORM 6 to FE3.
(This FEA is only required when the “PI” is determined in FE6.)
- 962:
- 963: Receive INFORM 4 from FE3, store
 - last forwarding number + restriction indicator;
 - originally called number + restriction indicator.
- 964: Send INFORM 4 to FE7;
restrict, if required, originally called number and/or last forwarding number.
- 965: Receive indication from the Basic Call of receipt of REPORT (alerting) req.ind. or SETUP resp.conf. and determine “PI” by interaction between the Basic Service, the Call Diversion and the COLR supplementary service.
(This FEA is only required when COLR is provided across the entire access.)
- 966: Relay any received INFORM 6.
- 967: Pass stored parameters to new FE3 (internal) when multiple forwarding occurs (not described in the SDL).

2.9.7 Functional Entity Actions for FE7

- 971: Send INFORM 6 to FE6.
- 972: Save forwarding parameters for use in the next FE4 (internal) when multiple forwardings apply (not described in the flows and SDLs).
- 973: Receive INFORM 4 from FE6.
- 974: Send INFORM 5 to FE8.
- 975: Receive indication from the Basic Call of receipt of REPORT (alerting) req.ind or SETUP resp.conf and determine “PI” by interaction between the Basic Service, the Call Diversion and the COLR supplementary service.

2.9.8 Functional Entity Actions for FE8

- 981: Receive indications related to the service from FE6 and present them to the called user.

2.10 Allocation of functional entities to physical locations

The possible physical locations of functional entities are shown in Table 2-14.

TABLE 2-14/Q.82

Scenarios for Call Forwarding

Scenario	A Party		B1 Party			C Party		
	FE1	FE2	FE3	FE4	FE5	FE6	FE7	FE8
1	TE	LE	LE	LE	TE	LE	LE	TE
2	PNX	LE	LE	LE	TE	LE	LE	TE
3	TE	LE	PNX	PNX	TE	LE	LE	TE
4	TE	LE	LE	LE	TE	LE	PNX	TE
5	PNX	LE	LE	LE	TE	LE	PNX	TE
7	TE	LE	PNX	PNX	TE	LE	PNX	TE
8 (Note 1)	TE	LE	LE	LE	PNX	LE	LE	TE
9 (Note 1)	TE	LE	LE	LE	PNX	LE	PNX	TE
10	TE	LE	LE	PNX	TE	LE	LE	TE
11	PNX	LE	LE	PNX	TE	LE	LE	TE
12	TE	LE	LE	PNX	TE	LE	PNX	TE
13	PNX	LE	LE	PNX	TE	LE	PNX	TE

NOTES

- 1 All calls to the PNX FE5 are diverted to the same forwarded-to number.
- 2 The network provider may limit the number of calls simultaneously diverted from a particular access.
- 3 The provision of partial rerouting is a public network provider option. In networks which provide partial rerouting, PNXs may operate scenarios 10, 11, 12 and 13.

Annex A

(to clause 2)

(This annex forms an integral part of this Recommendation)

A.2.1 Multiple diversion address handling

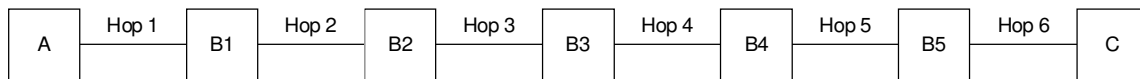

T1126660-90/d31

FIGURE A.2-1/Q.82

Hops

TABLE A.2-1/Q.82

Information carried in the INFORM 4 req.ind.

Parameter	Hop 1	Hop 2	Hop 3	Hop 4	Hop 5	Hop 6
Calling party number	A	A	A	A	A	A
Calling party address	B1	B2	B3	B4	B5	C
Last forwarding number (subscription option)		B1	B2	B3	B4	B5
Original called number (subscription option)		B1	B1	B1	B1	B1
Forwarding counter		1	2	3	4	5
Last forwarding cause		V(B1) (Note)	V(B2) (Note)	V(B3) (Note)	V(B4) (Note)	V(B5) (Note)
Original forwarding cause		V(B1) (Note)	V(B1) (Note)	V(B1) (Note)	V(B1) (Note)	V(B1) (Note)

NOTE 1 – (B) indicates the reason for forwarding from party B with a value (V) equal to: unknown/not available, user busy, no reply, unconditional, deflection (immediate response) or deflecting (alerting) when forwarding occurs.

TABLE A.2-2/Q.82

Information in the backwards direction to A Party (r_b)

Parameter	Hop 1	Hop 2	Hop 3	Hop 4	Hop 5	Hop 6
Subscription options for notification from		B1	B2	B3	B4	B5
Forwarded-to-number from ^{a)}		B1	B2	B3	B4	B5
Presentation indicator		b)	b)	b)	b)	C

^{a)} Optionally.
^{b)} Only when an alerting state is reached at B_n (CFNR, CD).

A.2.2 Explanatory model for multiple diversion

Figure A.2-2 contains an explanatory model for multiple diversions.

In Figure A.2-2 the functional model is mapped on a model for a basic call. When Call Forwarding is implemented by forward switching, FE3 and FE4 are always co-located at the same CC.

The different hops of a call encountering several diversions are linked at the level of the basic call.

In the nodes (CCs) where new hops occur, both the FE6 resp. FE7 of the last hop and FE3 resp. FE4 of the new hop must be co-located.

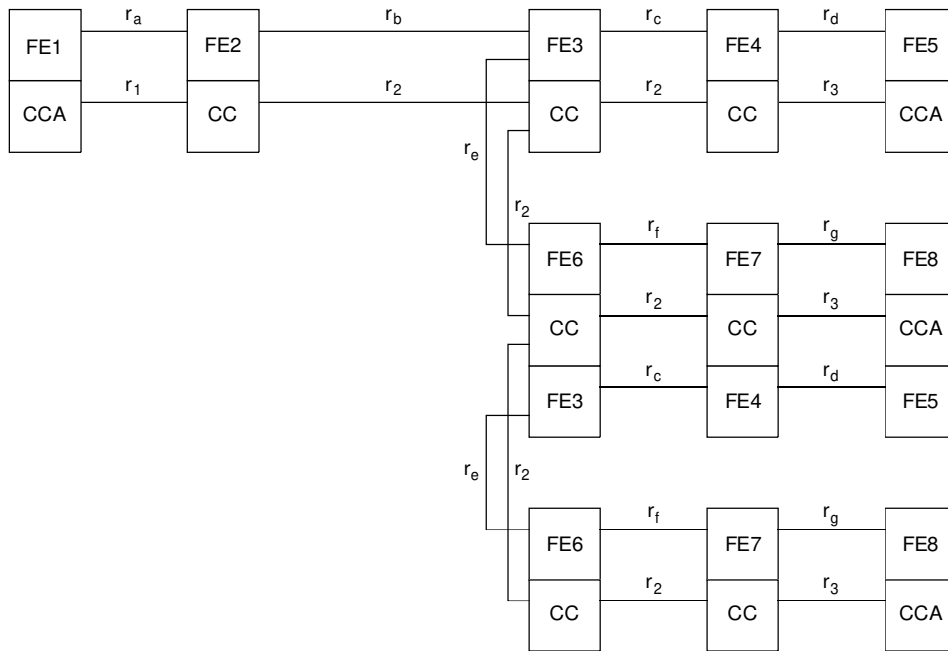

T1132790-91/d32

FIGURE A.2-2/Q.82
Explanatory model for multiple diversions

Annex B (to clause 2)

Activation, deactivation, registration and interrogation

(This annex forms an integral part of this Recommendation)

B.2.1 Definitions

In addition to the CF supplementary service, the following definitions apply:

Supplementary Service Control (SSC) – The SSC is responsible for the activation, deactivation and interrogation of the supplementary service. The SSC consists of the following service control entities (SCE):

SCE1, Service Controller's Agent – This entity provides the functionality enabling the controller to activate and deactivate the supplementary service.

SCE2, Profile Control and Service – This entity acts under the instructions from SCE1, making modifications to the global data associated with the service profile. It also supplies information to SCE3 about changes to the service, and responds to interrogation requests from SCE3.

SCE3, Service User's Agent – This entity provides the functionality enabling the user to interrogate the supplementary service, and receives notification of changes to the service.

GD, Global Data – This is data which is available to the Service Profile process in order to determine the states of the controlled supplementary service, and service specific details such as the nominated number. The global data can be modified only via SCE2.

B.2.2 Symbols and abbreviations

See subclause 2.4.

B.2.3 Description

To activate CF, the served user must supply:

- 1) the forwarded-to number, which may be accompanied by a forwarded-to sub-address;
- 2) information as to whether all calls or all calls of a specified basic service should be forwarded;
- 3) possibly the ISDN number for which CF should apply (e.g. MSN).

Deactivation is possible in either of two ways:

- 1) the user can specifically deactivate the CF activation, whereupon the network shall discard the forwarded-to number;
- 2) the user can activate CF for the specified basic service to another number, thus causing the previous invocation of CF to be overridden.

Interrogation should be possible by means of an appropriate request. The network response to such a request should provide the relevant information for the user.

B.2.4 Derivation of the functional model

B.2.4.1 Functional model description

The functional model is shown in Figure B.2-1.

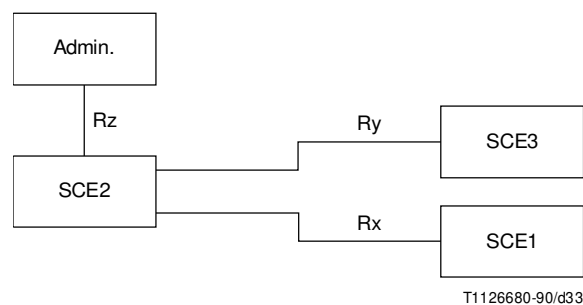

NOTE – SCE1 provides only the additional functionality required to activate and deactivate the service. As a result every SCE1 must have an associated SCE3, although SCE3 can stand alone.

FIGURE B.2-1/Q.82
Functional Model

B.2.4.2 Description of the functional service control entities

- SCE1: Service controller's agent
- SCE2: Profile control and service
- SCE3: Service user's agent.

B.2.4.3 Relationship with a basic service

The relationship with a basic service is shown in Figure B.2-2.

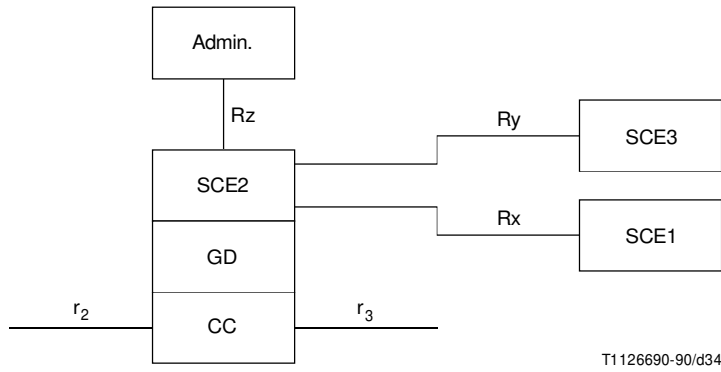

**FIGURE B.2-2/Q.82
Relationship with Basic Service**

B.2.4.4 Relationship of the user's SCM to the CF functional entity model

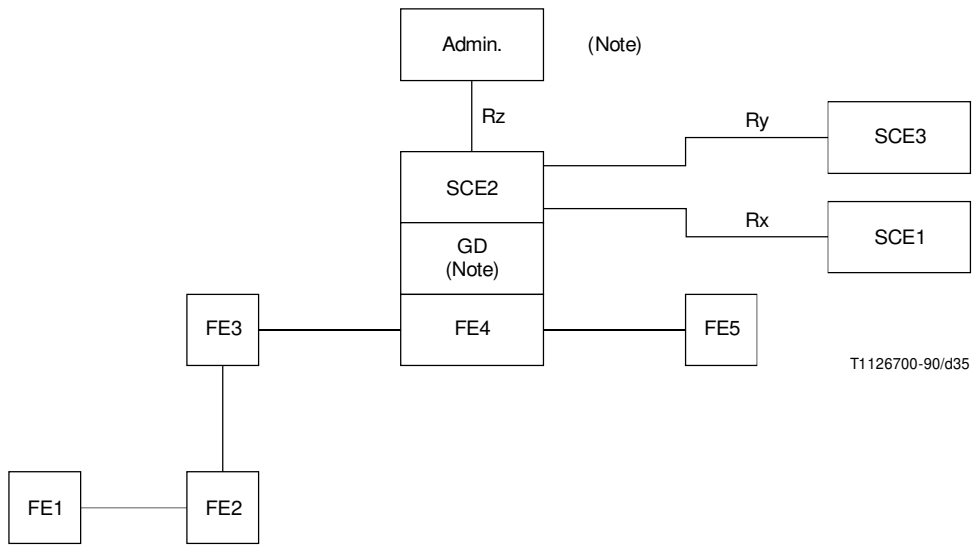

NOTE – Outside the scope of this Recommendation.

**FIGURE B.2-3/Q.82
Relationship to Functional Model**

B.2.5 Information flows

B.2.5.1 Information flow diagram for the supplementary service control

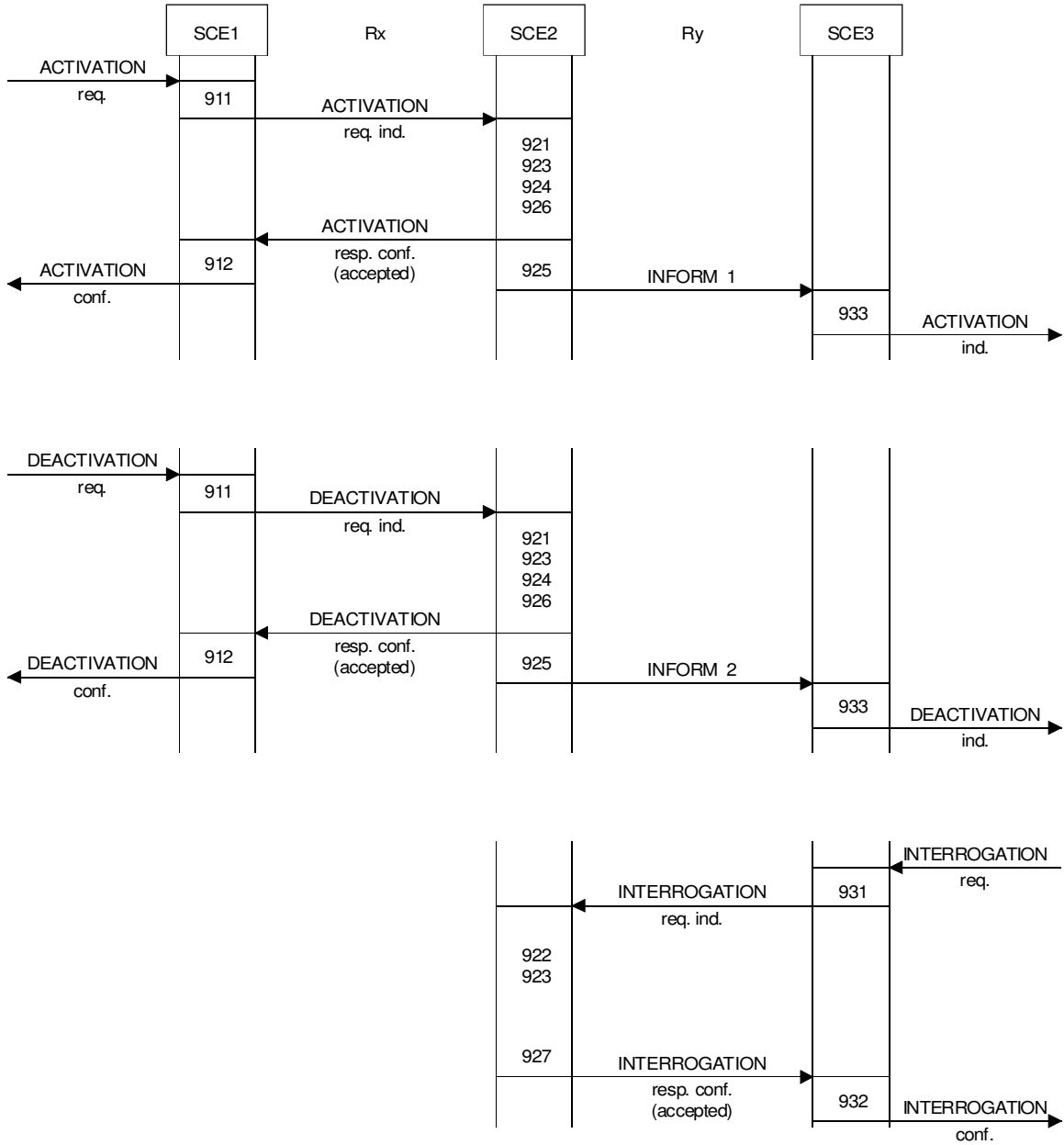

T1132800-91/d36

FIGURE B.2-4/Q.82
Information flow

B.2.5.2 Definition of individual information flows

Relationship Rx

SCE1 to SCE2

ACTIVATION req.ind

- FTN (may be accompanied by a sub-address)
- information as to whether:
 - all calls; or
 - all calls of a specified Basic Service should be forwarded
- ISDN number for which CF should apply (e.g. MSN)

SCE2 to SCE1

ACTIVATION resp.conf

- activation accepted, incl. FTN
- activation not accepted with cause, possible causes are:
 - service not subscribed to
 - use of an operator access prefix
 - insufficient information
 - forwarded-to number is a special service code (e.g. police)
 - forwarded-to number is served user's number
 - forwarded-to number is invalid ISDN number
 - Basic Service to which relevance is requested is not subscribed to

SCE1 to SCE2

DEACTIVATION req.ind

- deactivation of CF, including FTN to be discarded
- information as to whether diversion of:
 - all calls; or
 - all calls of the specified Basic Service should be cancelled
- ISDN number for which Call Forwarding should be deactivated

SCE2 to SCE1

DEACTIVATION resp.conf

- deactivation accepted
- deactivation not accepted with cause, e.g.
 - incorrect origination ISDN number

Relationship Ry

SCE2 to SCE3

INFORM 1

- activation of CF with FTN and specified Basic Service(s)

INFORM 2

- deactivation of CF with the specified Basic Service(s)

SCE3 to SCE2

INTERROGATION req.ind

- appropriate request

SCE2 to SCE3

INTERROGATION resp.conf

- activated or deactivated state of the supplementary service
- if activated:
 - FTN(s)
 - activated for which Basic Service(s)
- ISDN number(s) to which the response applies

B.2.6 SDL diagrams for the service control entities

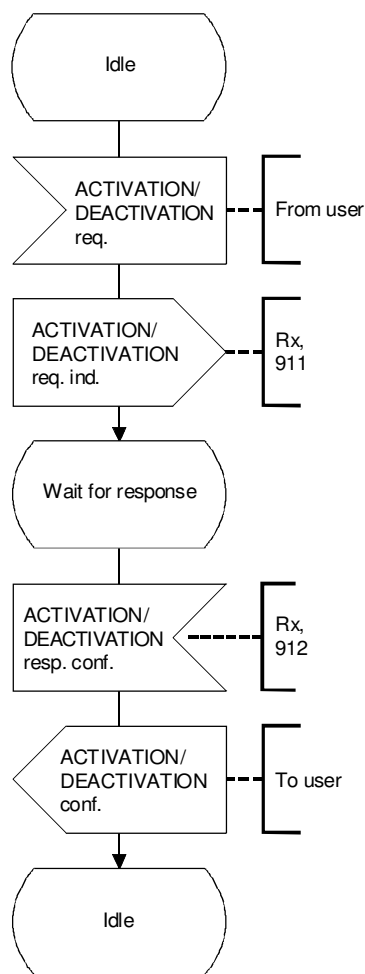

T1126720-90/d37

FIGURE B.2-5/Q.82
SCE1 function of supplementary service control

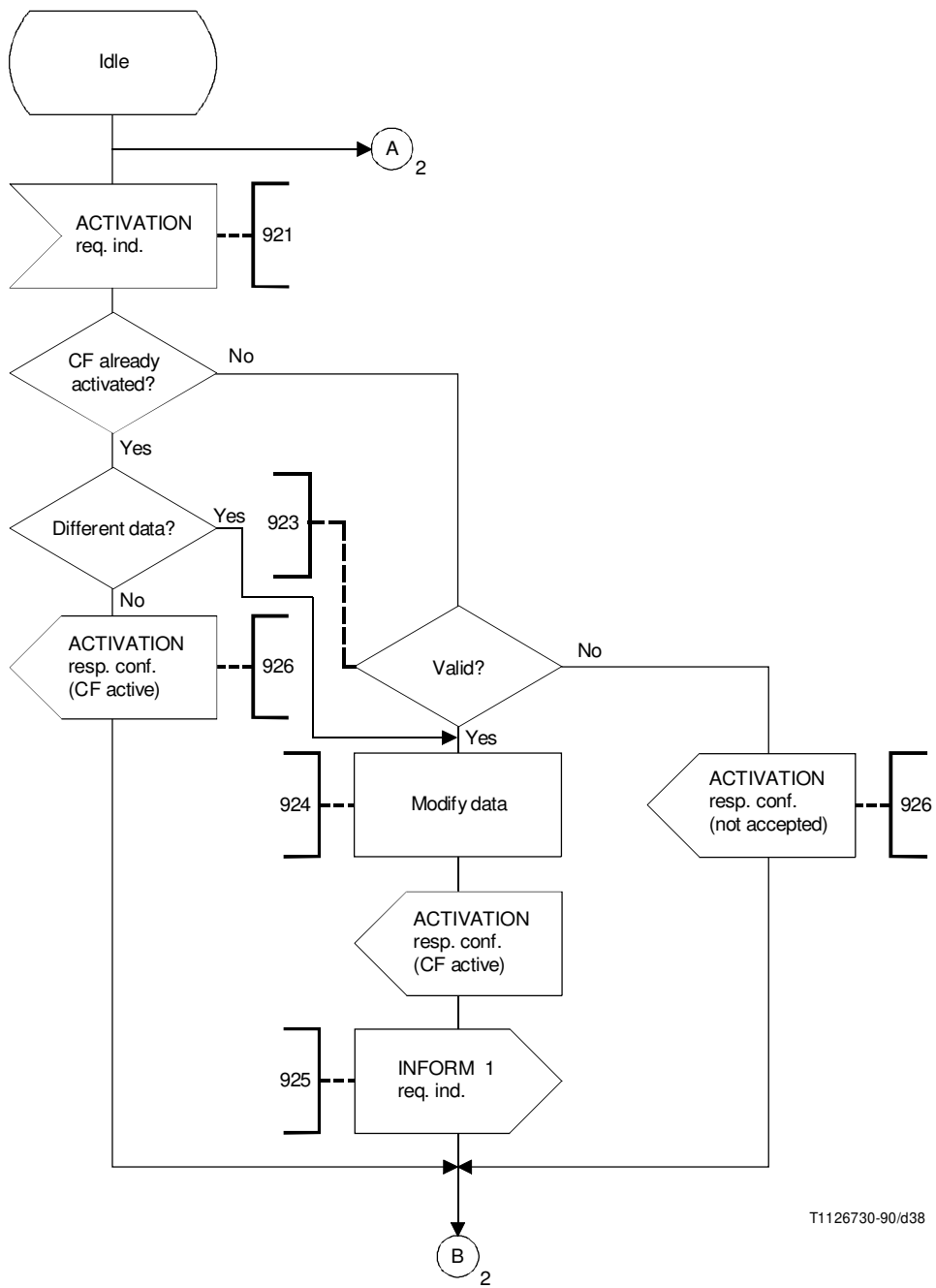
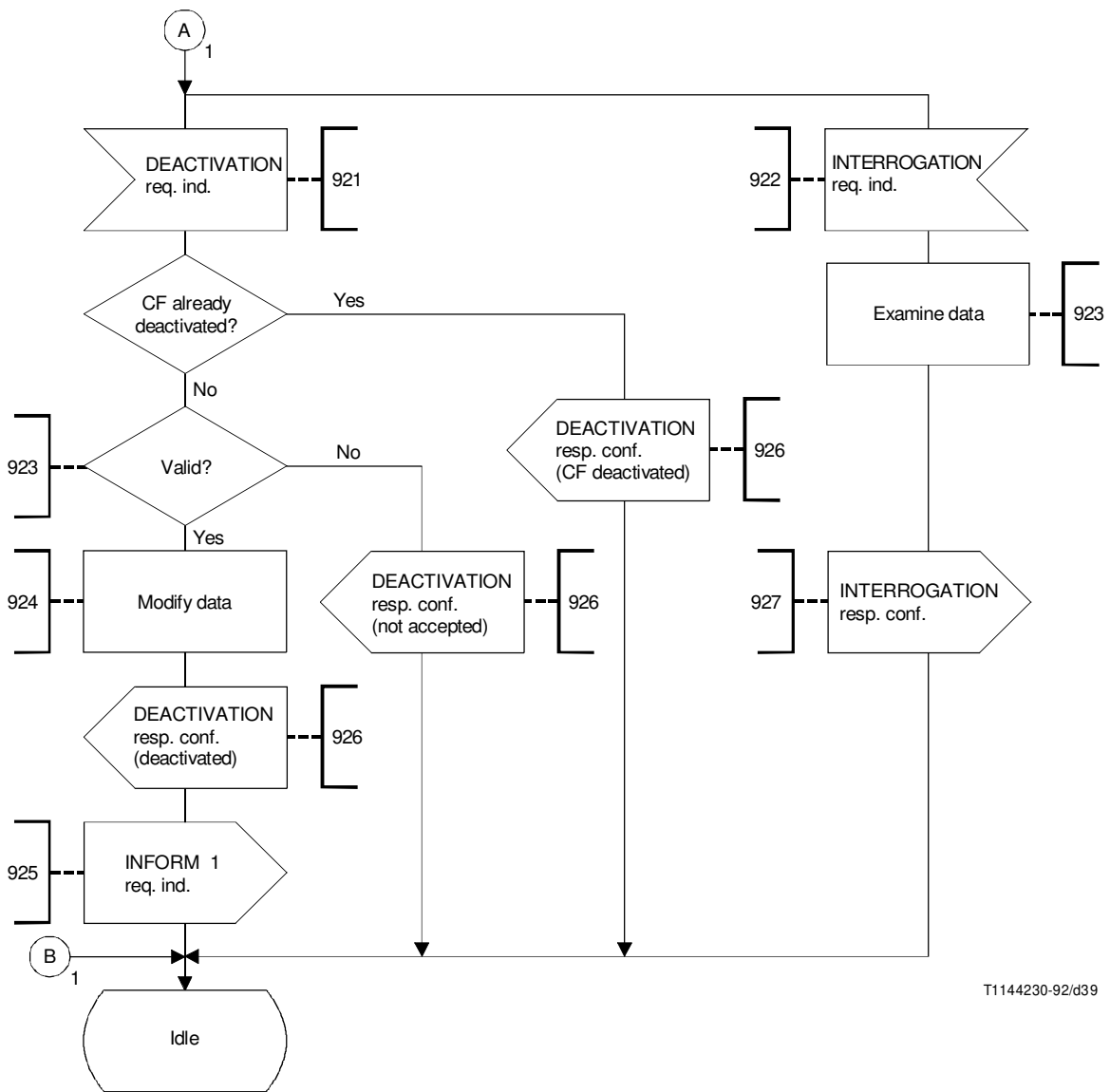
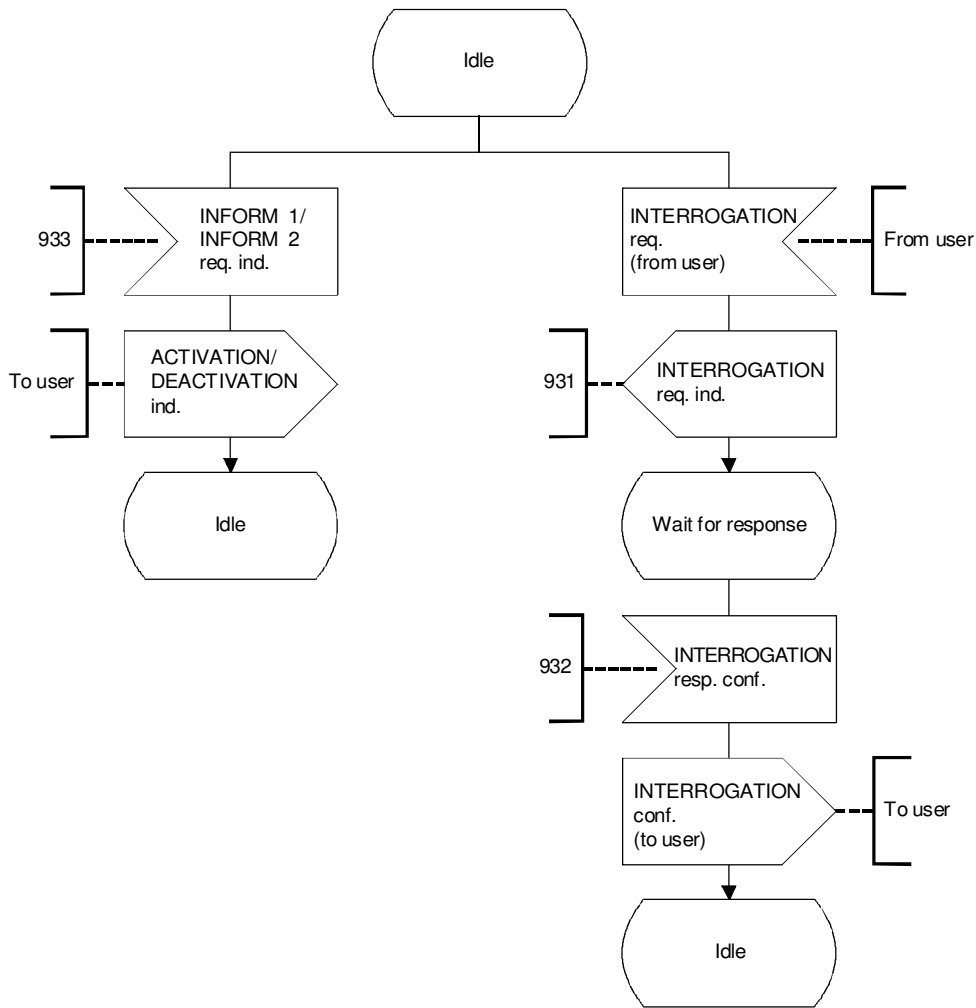

FIGURE B.2-6/Q.82 (sheet 1 of 2)
SCE2 functions of supplementary service control



T1144230-92/d39

FIGURE B.2-6/Q.82 (sheet 2 of 2)
SCE2 functions of supplementary service control



T1132810-91/d40

FIGURE B.2-7/Q.82
SCE3 function of supplementary service control

B.2.7 Service control entity actions

B.2.7.1 SCEA of SCE1

911: Formulate and forward activation and deactivation requests received from the controller to SCE2.

912: Receive responses relating to the success or failure of the requested action.

B.2.7.2 SCEA of SCE2

921: Receive requests for activation and deactivation from SCE1.

922: Receive requests for interrogation from SCE3.

- 923: Validate requests on the basis of correct information content and user authority.
- 924: Update relevant global data on receipt of valid activation and deactivation requests.
- 925: Inform all SCE3s of successful modifications to services.
- 926: Inform the requesting SCE of the success or failure of requests, and register charge in case of successful activation.
- 927: Respond to valid requests for interrogation from SCE3 by formulating the response and forwarding it to the requesting SCE3.

B.2.7.3 SCEA of SCE3

- 931: Formulate and forward interrogation received from the user to SCE2.
- 932: Receive responses to interrogation requests.
- 933: Receive notification from SCE2 of successful activations and deactivations made by any SCE1.

B.2.8 Allocation of service control entities to physical locations

Scenarios	B Party	
	SCE1/3	SCE2
1	TE	LE
2	TE	PNX

3 Call deflection

3.1 Scope

This Recommendation defines the stage 2 for the Call Deflection (CD) supplementary service of Integrated Services Digital Network (ISDN) as provided by public telecommunications operators. Stage 2 identifies the functional capabilities and the information flows needed to support the service description. The stage 2 description also identifies user operations not directly associated with a call (see Recommendation I.130 [1]).

This Recommendation is specified according to the methodology specified in Recommendation Q.65 [2].

This Recommendation does not formally describe the relationship between this supplementary service and the basic call, but where possible this information is included for guidance.

In addition, this Recommendation does not specify the requirements where the service is provided to the user via a private ISDN. This Recommendation does not specify the requirements for the allocation of defined functional entities within a private ISDN; it does however define which functional entities may be allocated to a private ISDN.

This Recommendation does not specify the additional requirements where the service is provided to the user via a telecommunications network that is not an ISDN.

This Recommendation describes the Call Deflection supplementary services, when implemented using the “forward switching” network routing algorithm and partial rerouting at the public/private network interface as contained in Recommendation Q.80 [3].

The description of full rerouting as described in Recommendation Q.80 is outside the scope of this Recommendation.

The CD supplementary service permits a served user to, in real time, request that the network redirects an incoming call addressed to the served user’s ISDN number to another number. The served user’s originating service is unaffected.

This Recommendation is applicable to the stage 3 Recommendations for the ISDN CD supplementary service. The term “stage 3” is also defined in Recommendation I.130 [1]. Where the text indicates the status of a requirement, i.e. as strict command or prohibition, as authorization leaving freedom, as a capability or possibility, this shall be reflected in the text of the relevant stage 2 and stage 3 Recommendations.

Furthermore, conformance to this Recommendation is met by conforming to the stage 3 Recommendations with the field of application appropriate to the equipment being implemented. Therefore, no method of testing is provided for this Recommendation.

3.2 References

This Recommendation incorporates by dated or undated reference, provisions from other publications. These references are cited at the appropriate places in the Recommendation and the publications are listed hereafter. For dated references, subsequent amendments to, or revisions of any of these publications apply to this Recommendation only when incorporated in it by amendment or revision. For undated references the latest edition of the publication referred to applies.

- [1] CCITT Recommendation I.130 *Method for the characterization of telecommunication services supported by an ISDN and network capabilities of an ISDN*, 1988.
- [2] CCITT Recommendation Q.65 *Stage 2 of the method for the characterization of services supported by an ISDN*, 1988.
- [3] CCITT Recommendation Q.80 *Introduction to Stage 2 Service descriptions for supplementary services*, 1988.
- [4] CCITT Recommendation Q.71 *ISDN 64 kbit/s circuit mode switched bearer service*, 1992.
- [5] CCITT Recommendation I.112 *Vocabulary of terms for ISDNs*, 1988.
- [6] CCITT Recommendation E.164 *Numbering plan for the ISDN era*, 1988.
- [7] CCITT Recommendation I.252.5 *Call Deflection (CD)*, 1992.

3.3 Definitions

For the purpose of this Recommendation, the following definitions apply:

Integrated Services Digital Network (ISDN): See 2.3/I.112 [5], definition 308.

Service – telecommunications service: See 2.2/I.112 [5], definition 201.

ISDN number: A number conforming to the numbering plan and structure specified in Recommendation E.164 [6].

Originally Called Number: The number of the B1-party.

Connected Number: The number of the final destination.

Forwarding Number: The number of the served user, i.e. the subscriber who initiates the forwarding service and from where the call has been forwarded.

deflected to number (DTN): The number to which a call has been deflected.

Forwarding Indicator (FI): Indicator showing that a call has been forwarded and indicating whether this information should be given to the calling party.

Presentation Indicator (PI): Indicator showing whether the DTN should be presented to the calling user, as derived from the C-party's COLR supplementary service.

Forwarding Cause: Parameter which contains the forwarding reason, e.g. CFU, CFB, CFNR, CD.

Network Facility Indicator (NFI): Indicator showing the preferred transit network to be used for deflection.

Redirecting Number Presentation Indicator (RPI): Indicator showing whether the Forwarding Number should be allowed to be presented to the deflected-to user.

3.4 Symbols and abbreviations

Abbreviations used:

BC	Basic Call
CC	Call Control
CCA	Call Control Agent
CD	Call Deflection
CFB	Call Forwarding Busy
CFNR	Call Forwarding No Reply
CFPC	Call Forwarding Profile Control
CFU	Call Forwarding Unconditional
DTN	Deflected-to number
FC	Forwarding Cause
FE	Functional Entity
FI	Forwarding Indicator
LE	Local Exchange
NFI	Network Facility Indicator
NDUB	Network Determined User Busy
NSO	Notification Subscription Option
PI	Presentation Indicator
PN	Private Network
PNX	Private Network Exchange
RPI	Redirection Number Presentation Indicator
TE	Terminal Equipment
UDUB	User Determined User Busy

3.5 Description

The general description of the CD supplementary service is specified in I.252.5 [7].

3.6 Derivation of the functional model

3.6.1 Functional model description

The functional model for the CD supplementary service is shown in Figure 3-1.

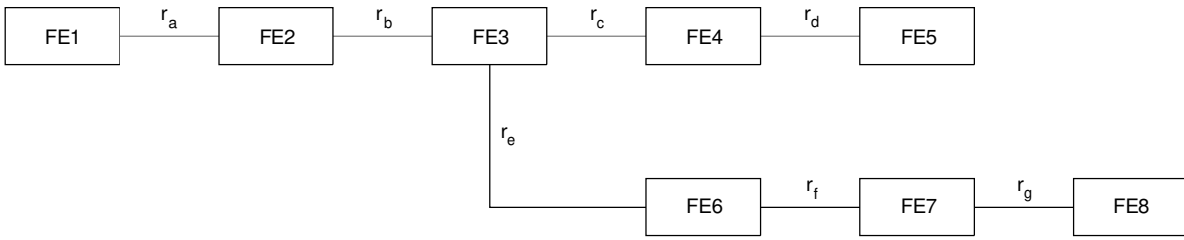

T1132720-91/d41

FIGURE 3-1/Q.82
Functional model

3.6.2 Description of the functional entities

The functional entities required by the CD supplementary service in addition to those of the basic call are as follows:

- FE1: Caller's service agent
- FE2: Caller's service control entity
- FE3: Call deflection execution entity
- FE4: Call deflection detection and control entity
- FE5: Served user's service agent
- FE6: Interface controlling entity
- FE7: Deflected-to user's service control entity
- FE8: Deflected-to user's service agent

3.6.3 Relationship with a basic service

The relationship with a basic service is shown in Figure 3-2.

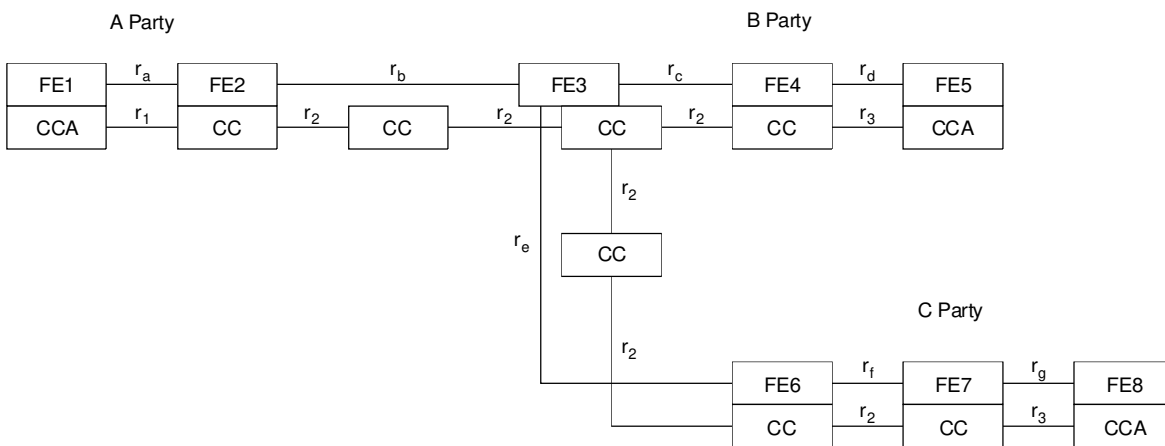

T1156510-93/d42

FIGURE 3-2/Q.82
Relationship with a basic service

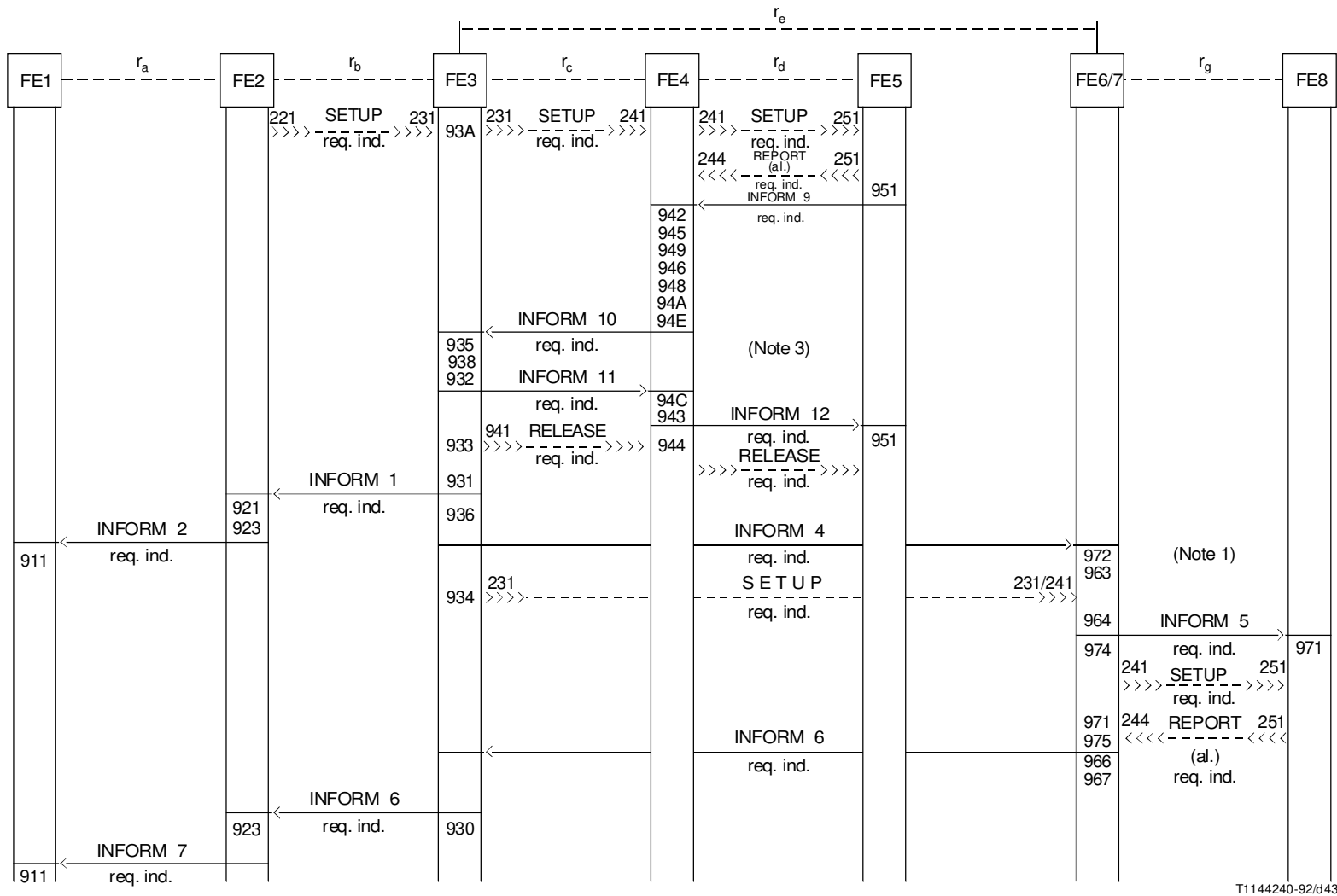

T1144240-92/d43

NOTE – The Notes are found after Figure 3-8.

FIGURE 3-3/Q.82
Call deflection, option B, early release of the served user

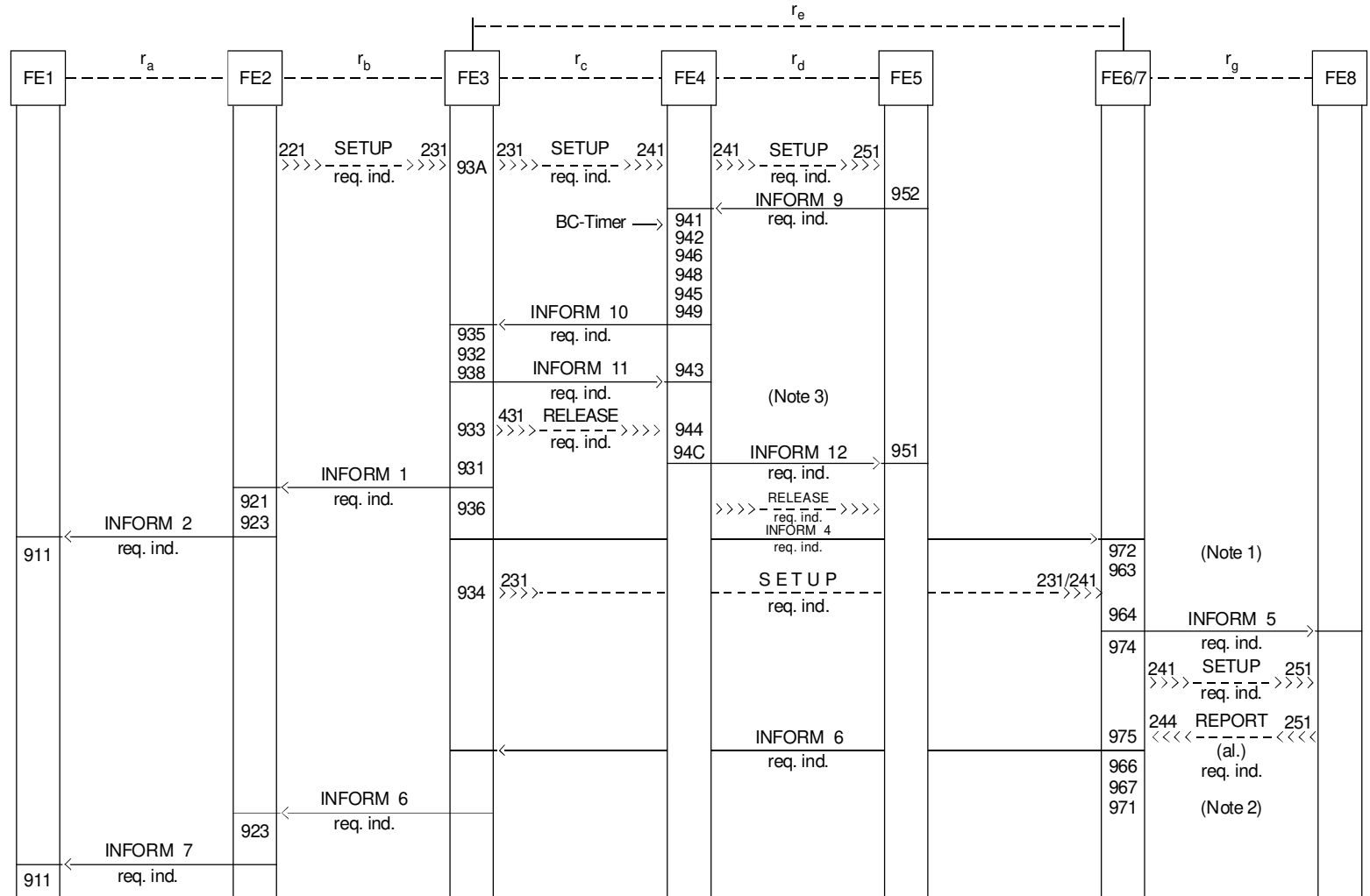

T1144250-92/d44

NOTE – The Notes are found after Figure 3-8.

FIGURE 3-4/Q.82

Call deflection, option B, early release of the served user, immediate response

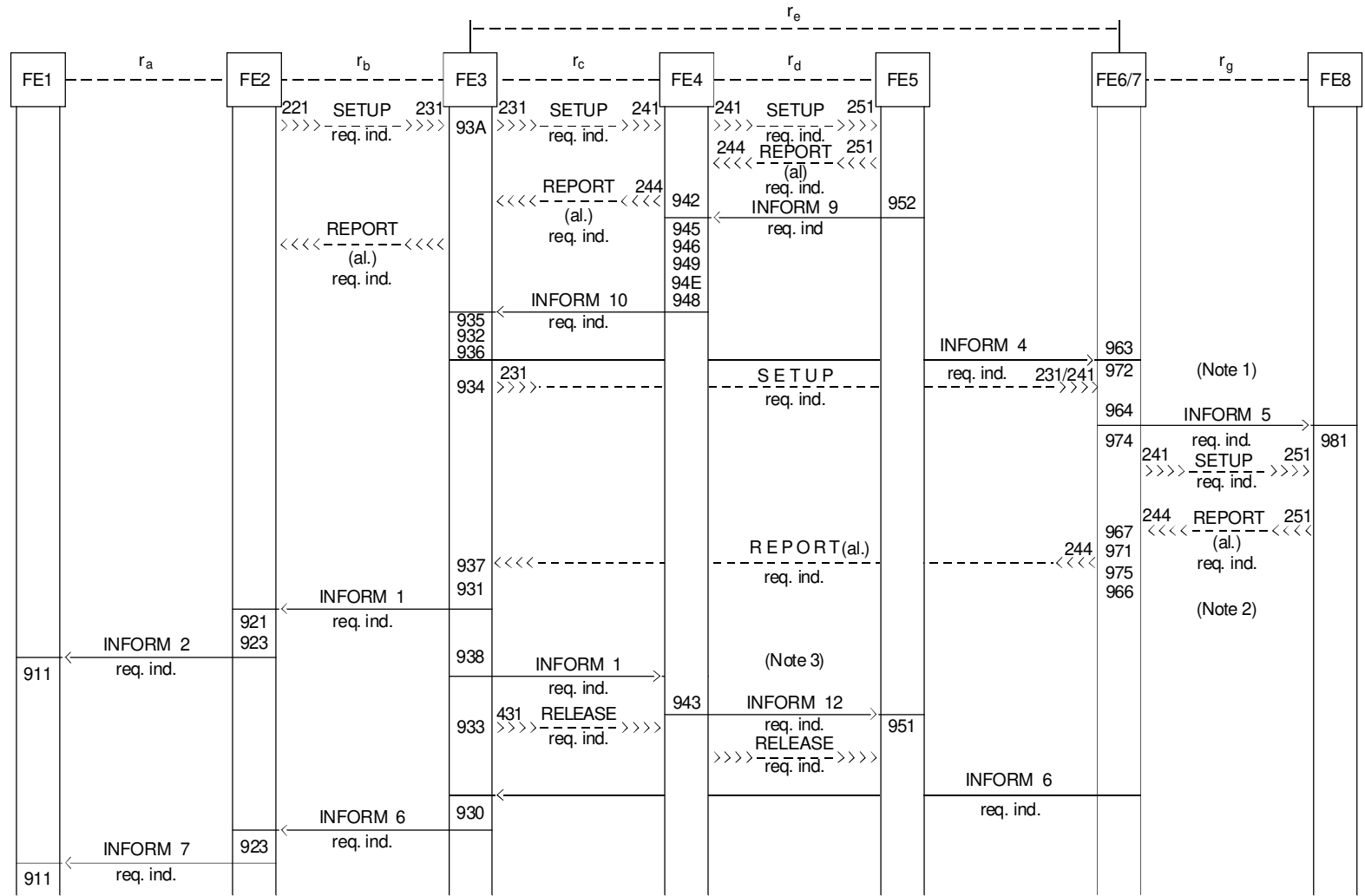

T1144260-92/d45

NOTE – The Notes are found after Figure 3-8.

FIGURE 3-5/Q.82
Call deflection, option A, late release of the served user, response during alerting phase

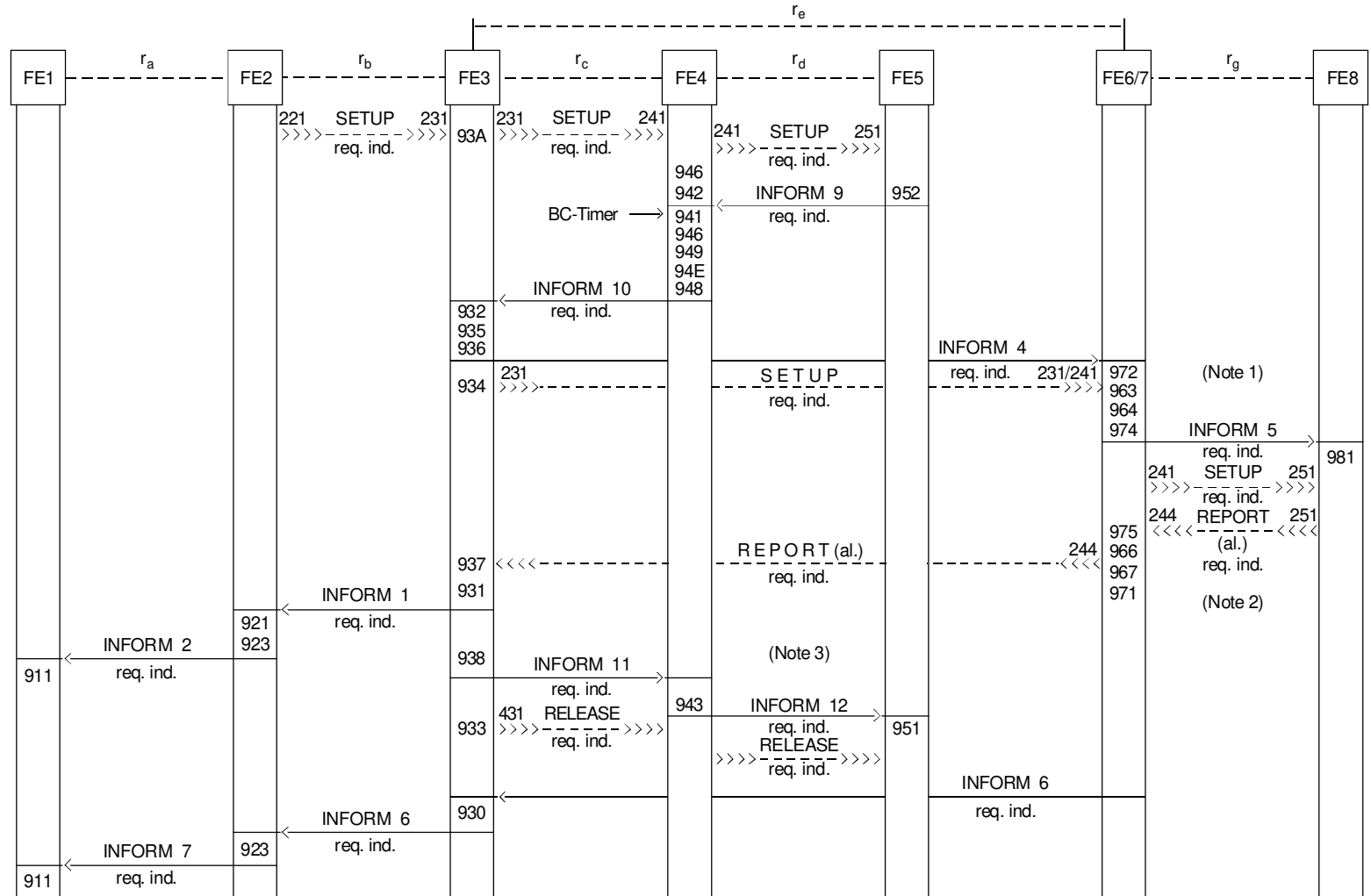

T1144270-92/d46

NOTE – The Notes are found after Figure 3-8.

FIGURE 3-6/Q.82

Call deflection, option A, late release of the served user, immediate response

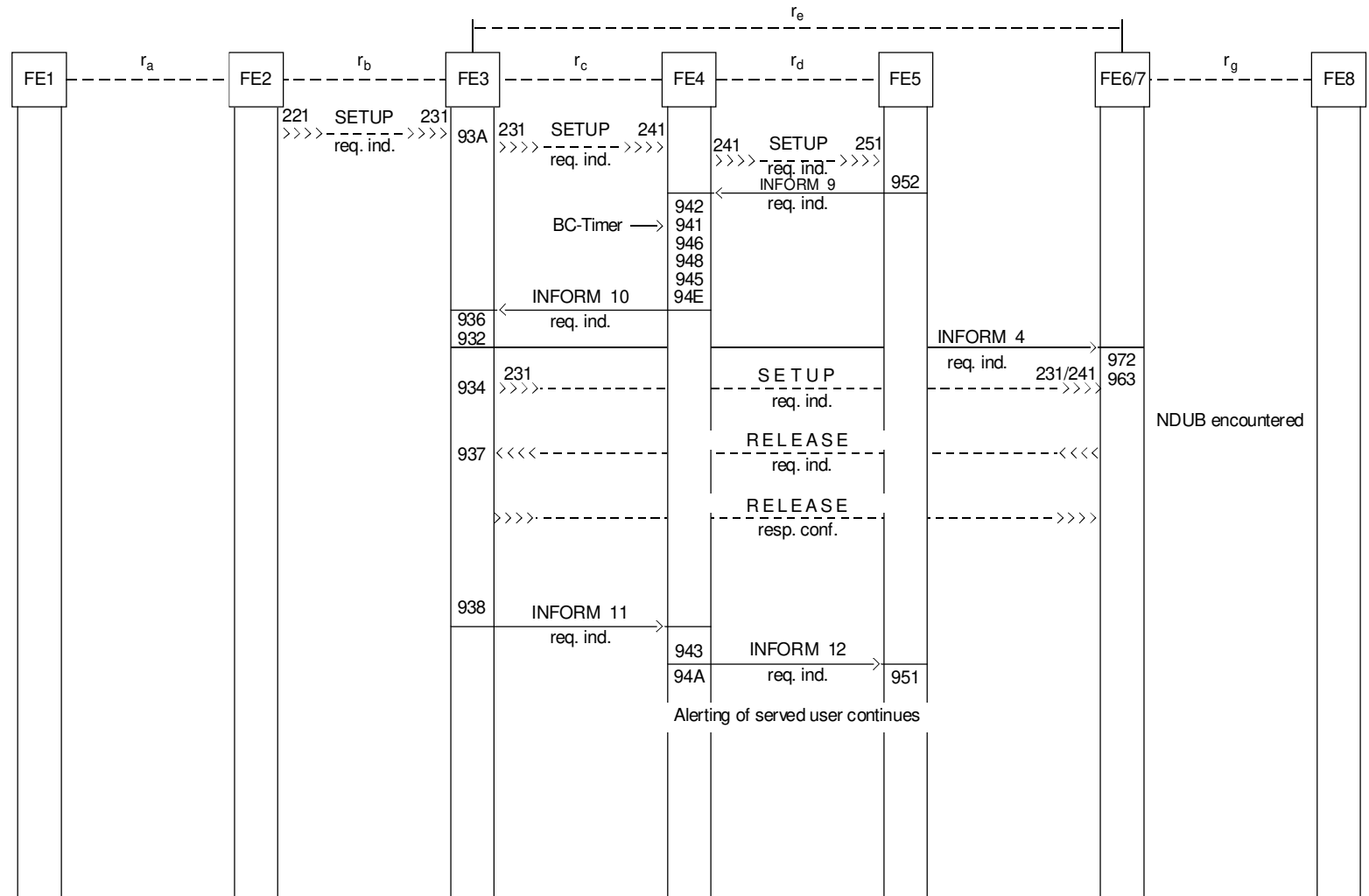

T1144280-92/d47

NOTE – The notes are found after Figure 3-8.

FIGURE 3-7/Q.82
Call deflection, option A, C-Party network determined user busy

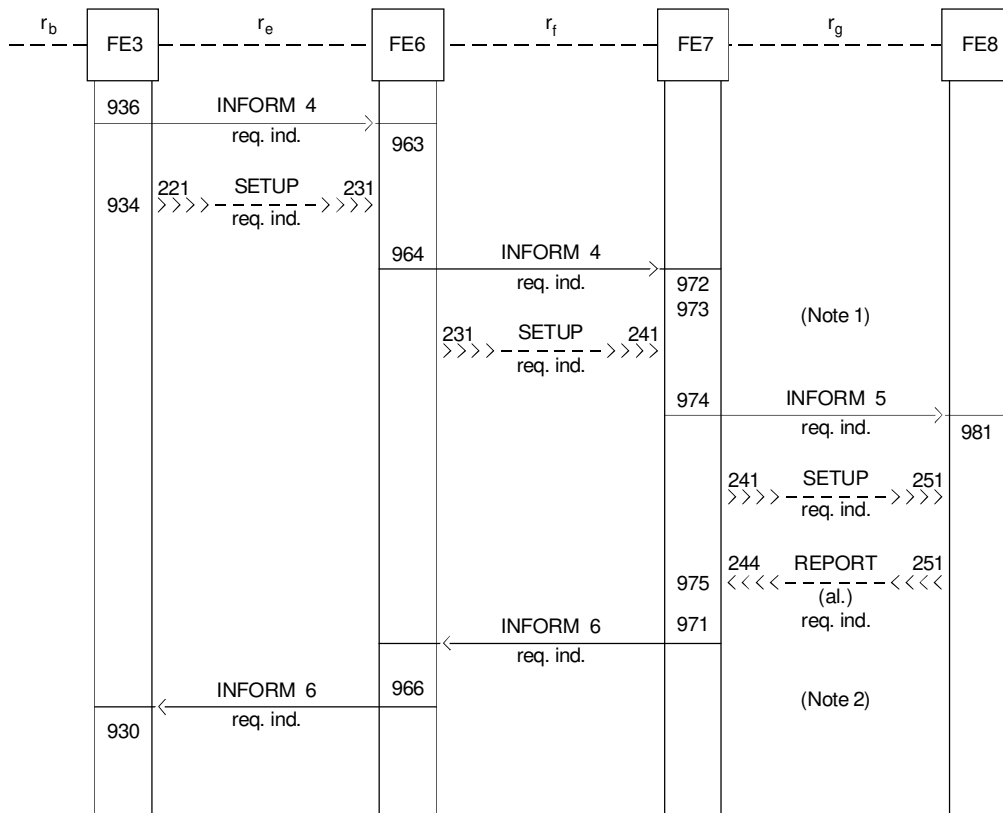

T1144290-92/d48

FIGURE 3-8/Q.82

Flows across the public/private network interface at C-Party

NOTES related to Figures 3-3 to 3-8:

- 1 The INFORM 5 shall be presented to FE8 not later than the associated SETUP req. ind.
- 2 In case of
 - COLR temporary mode; or
 - immediately responding terminals at C; the PI-value will be determined on receipt of SETUP resp. conf. from FE8.
- 3 The INFORM 12 shall be presented to FE5 at the same time as the associated RELEASE req. ind.

3.7.2 Definition of individual information flows

Relationship r_a

INFORM 2 (Notes 2 and 7)

The contents of INFORM 2 are shown in Table 3-1.

TABLE 3-1/Q.82

Parameter	Allowed value	req.ind
Forwarding indicator		M

INFORM 7 (Notes 3 and 7)

The contents of INFORM 7 are shown in Table 3-2.

TABLE 3-2/Q.82

Parameter	Allowed value	req.ind
Forwarded-to-number	– ISDN number – Number restricted – Number not available	M

Relationship r_b

INFORM 1 (Note 7)

The contents of INFORM 1 are shown in Table 3-3.

TABLE 3-3/Q.82

Parameter	Allowed value	req.ind
Forwarding indicator (FI) including notification subscription option	No Yes, without DTN Yes, with DTN	M
Forwarding cause	CD (immediate) CD (alerting)	M
Forwarded-to-number (Note)		O
NOTE – This optional refers to the situation in which the forwarded-to number is withheld on the basis of a network provider decision.		

INFORM 6 (Note 7)

The contents of INFORM 6 are shown in Table 3-4.

TABLE 3-4/Q.82

Parameter	Allowed value	req.ind
Presentation indicator	Presentation allowed Presentation not allowed	M

Relationship r_c

INFORM 10

The contents of INFORM 10 are shown in Table 3-5.

TABLE 3-5/Q.82

Parameter	Allowed value	req.ind
Cause for forwarding (CD)		M
Called party address (incl. DTN)		M
Forwarding indicator		M
Forwarding number		O
Restriction indicator for forw.#		M
Telecommunication service inf.		M
User-to-user information		O
Forwarding counter		M
Calling party sub-address		O
Network facility indicator		O
Redirecting number presentation indicator		O

INFORM 11

The contents of INFORM 11 are shown in Table 3-6.

TABLE 3-6/Q.82

Parameter	Allowed value	req.ind
Forwarding invocation result	Positive/negative acknowledgment	M

Relationship r_d

INFORM 9

The contents of INFORM 9 are shown in Table 3-7.

TABLE 3-7/Q.82

Parameter	Allowed value	req.ind
Forwarded-to-number	ISDN number	M
Forwarded-to-sub-address		O
Network facility indicator		O
Redirecting number presentation indicator		O

INFORM 12

The contents of INFORM 12 are shown in Table 3-8.

TABLE 3-8/Q.82

Parameter	Allowed value	req.ind
CD invocation result	Positive/negative acknowledgment	M
Served user's number		M
Telecom. service information		M

Relationship r_e

INFORM 4

The contents of INFORM 4 are shown in Table 3-9.

TABLE 3-9/Q.82

Parameter	Allowed value	req.ind
Forwarding cause		M
Forwarding number (Note 5)		M
Forwarding counter		M
Original called number (Note 5)		M

INFORM 6 (Note 7)

The contents of INFORM 6 are shown in Table 3-10.

TABLE 3-10/Q.82

Parameter	Allowed value	req.ind
Presentation Indicator for DTN	Presentation allowed Presentation not allowed	M ^{a)}
a) Mandatory in case of presentation allowed.		

Relationship r_f

INFORM 4

The contents of INFORM 4 are shown in Table 3-11.

TABLE 3-11/Q.82

Parameter	Allowed value	req.ind
Forwarding cause		M
Forwarding number (Note 5)		M
Forwarding counter		M
Originally called number (Note 5)		M

Relationship r_g

INFORM 5

The contents of INFORM 5 are shown in Table 3-12.

TABLE 3-12/Q.82

Parameter	Allowed value	req.ind
Last forwarding cause		M
Last forwarding number (Note 6)		O
Originally called number (Note 6)		O
Calling party address (Note 1)		O

The contents of INFORM 6 are shown in Table 3-13.

TABLE 3-13/Q.82

Parameter	Allowed value	req.ind
Presentation Indicator for DTN	Presentation allowed Presentation not allowed	M ^{a)}
a) Mandatory in case of presentation allowed.		

Notes related to this sub-clause (3.7.2) and to the tables:

1 The calling party address shall be included if required by the “calling line identification presentation supplementary service”, if not restricted.

2 The INFORM 2 shall be sent only if the B-party has subscribed to the subscription option “calling user receives notification his call has been forwarded”.

3 The forwarded-to number shall be sent to FE1 only if the B-party has subscribed to the additional option that notification can include the forwarded-to number and if the C-party has not invoked to COLR.

4 The INFORM 6 shall be sent after it has been determined that COLR will not be invoked, i.e.:

- COLR perm. mode not subscribed to;
- COLR temp. mode not subscribed to;
- COLR temp. mode subscribed but not invoked.

When COLR temp. mode is subscribed to but not invoked INFORM 6 will be sent when the COLP allowed presentation indicator is received at FE6.

5 This number will always be transferred in the network together with a “restriction indicator” whose value is set according to the subscription options of the user.

On boundaries between different networks or to private networks the number might not be passed depending on a network provider decision.

If provided, the redirecting number presentation indicator is used to set the “restriction indicator” for the forwarding number, overriding the user’s default subscription options.

6 This number shall only be included if no restrictions exist.

7 Notification of diversion of the calling user may be provided as a network provider option. If provided by the network, the network shall support the functional entity actions/information flows necessary for the “calling user receives notification that his call has been diverted” subscription option.

If not provided by the network, the network will not support the functional entity actions/information flows necessary for the “calling user receives notification that his call has been diverted” subscription option.

3.8 SDL diagrams for functional entities

Notification of diversion of the calling user may be provided as a network provider option. If provided by the network, the network shall support the functional entity actions/information flows necessary for the “calling user receives notification that his call has been diverted” subscription option.

If not provided by the network, the network will not support the functional entity actions/information flows necessary for the “calling user receives notification that his call has been diverted” subscription option.

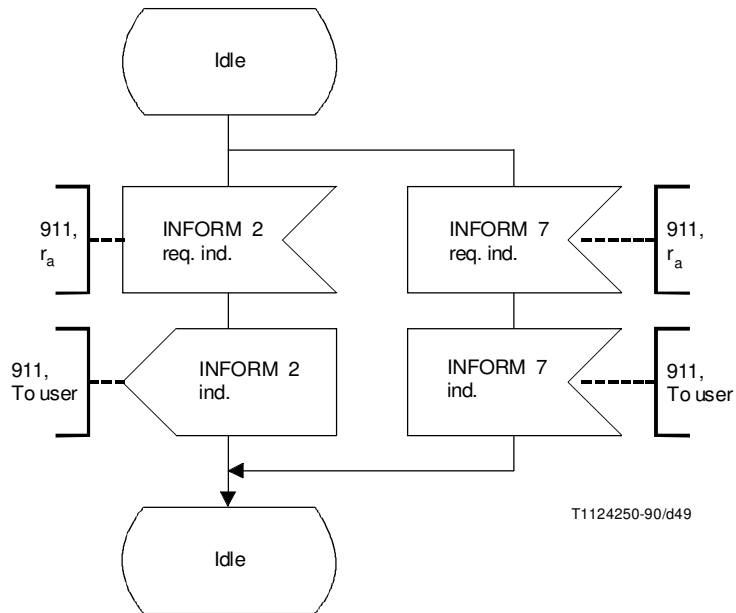
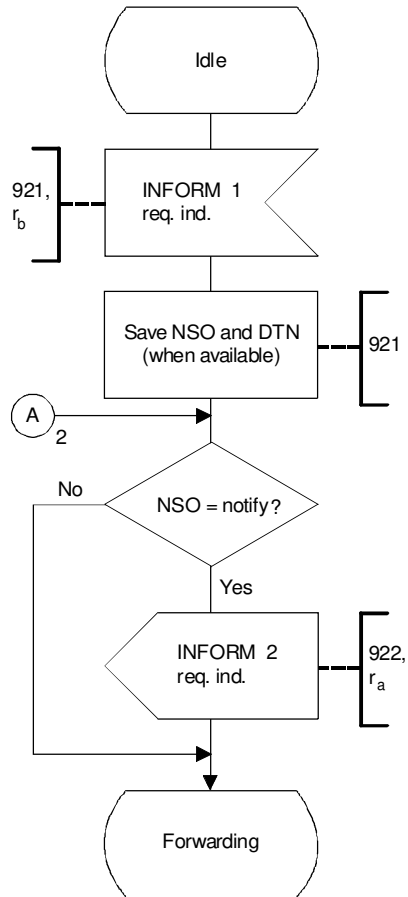
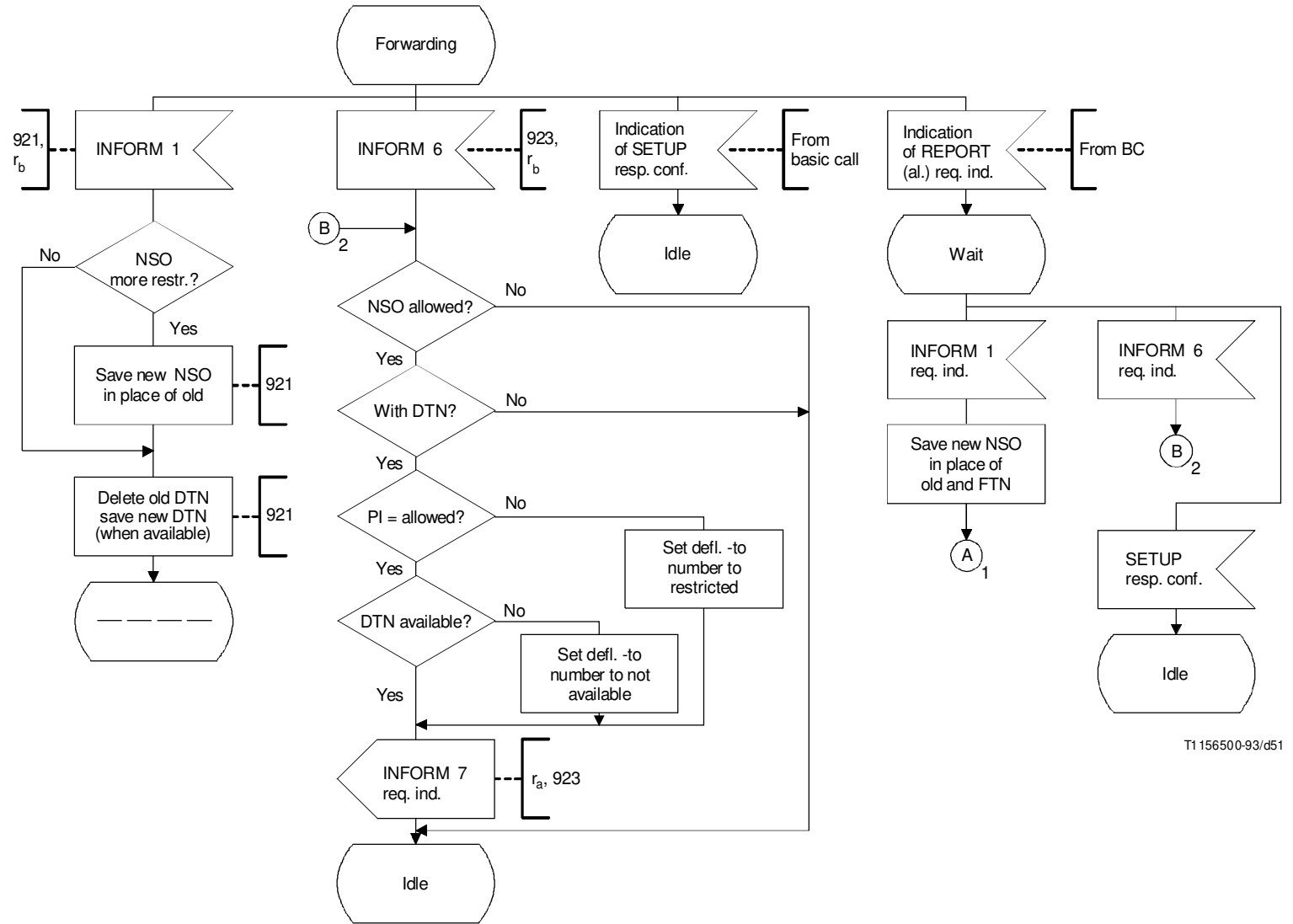

FIGURE 3-9/Q.82
Functional entity FE1 call diversion



T1124260-90/d50

FIGURE 3-10/Q.82 (sheet 1 of 2)
Functional entity FE2 call diversion



T1 156500-93/d51

FIGURE 3-10/Q.82 (sheet 2 of 2)
 Functional entity FE2 call diversion

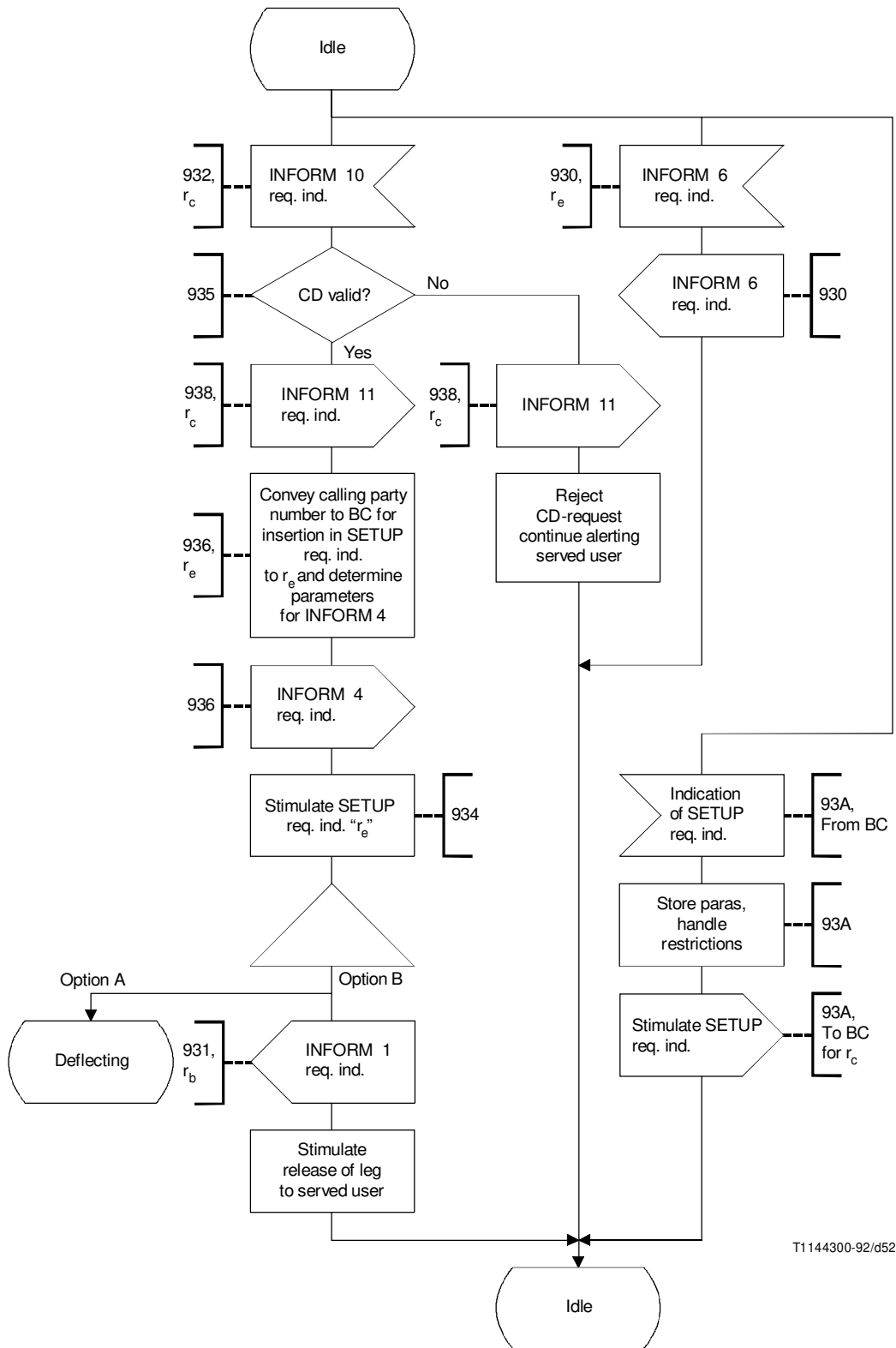

T1144300-92/d52

FIGURE 3-11/Q.82 (sheet 1 of 2)

Functional entity FE3 call deflection

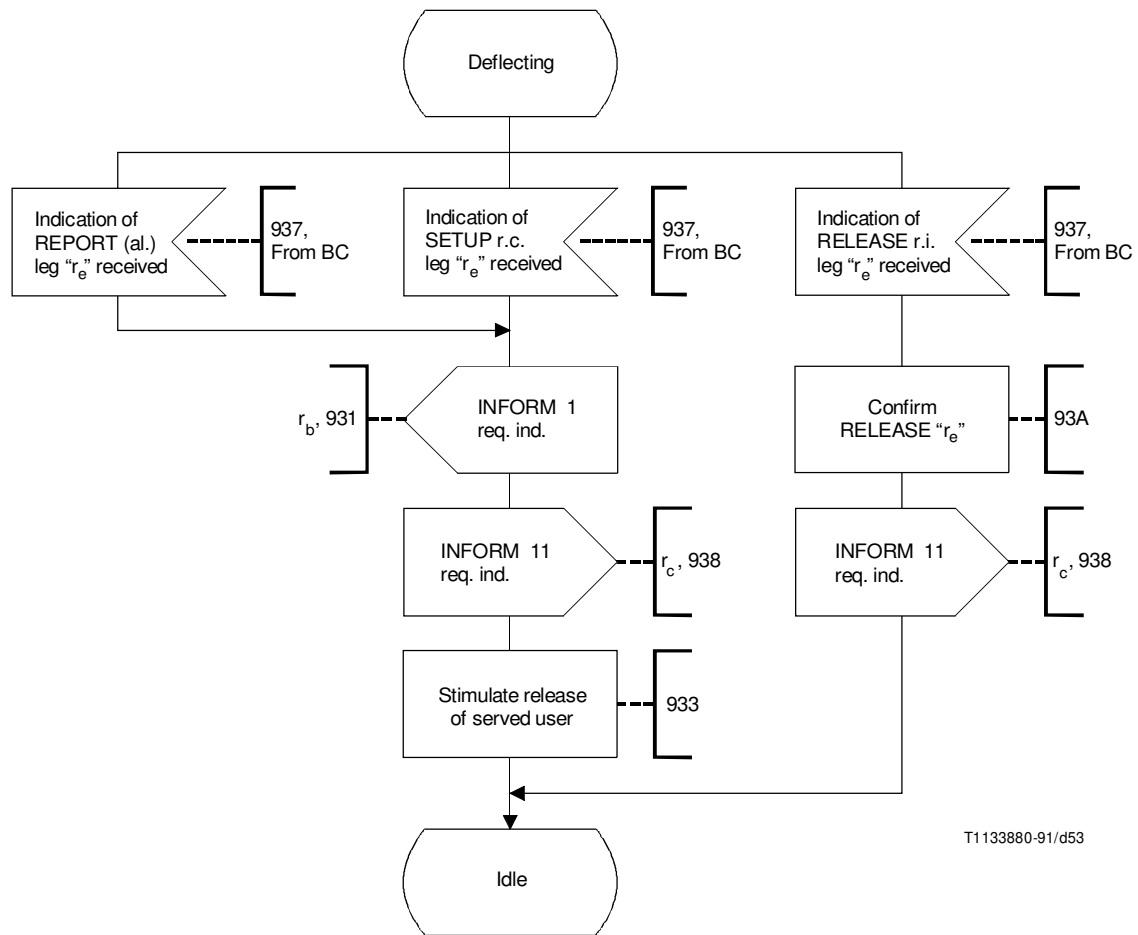

T1133880-91/d53

FIGURE 3-11/Q.82 (sheet 2 of 2)
Functional entity FE3 call deflection

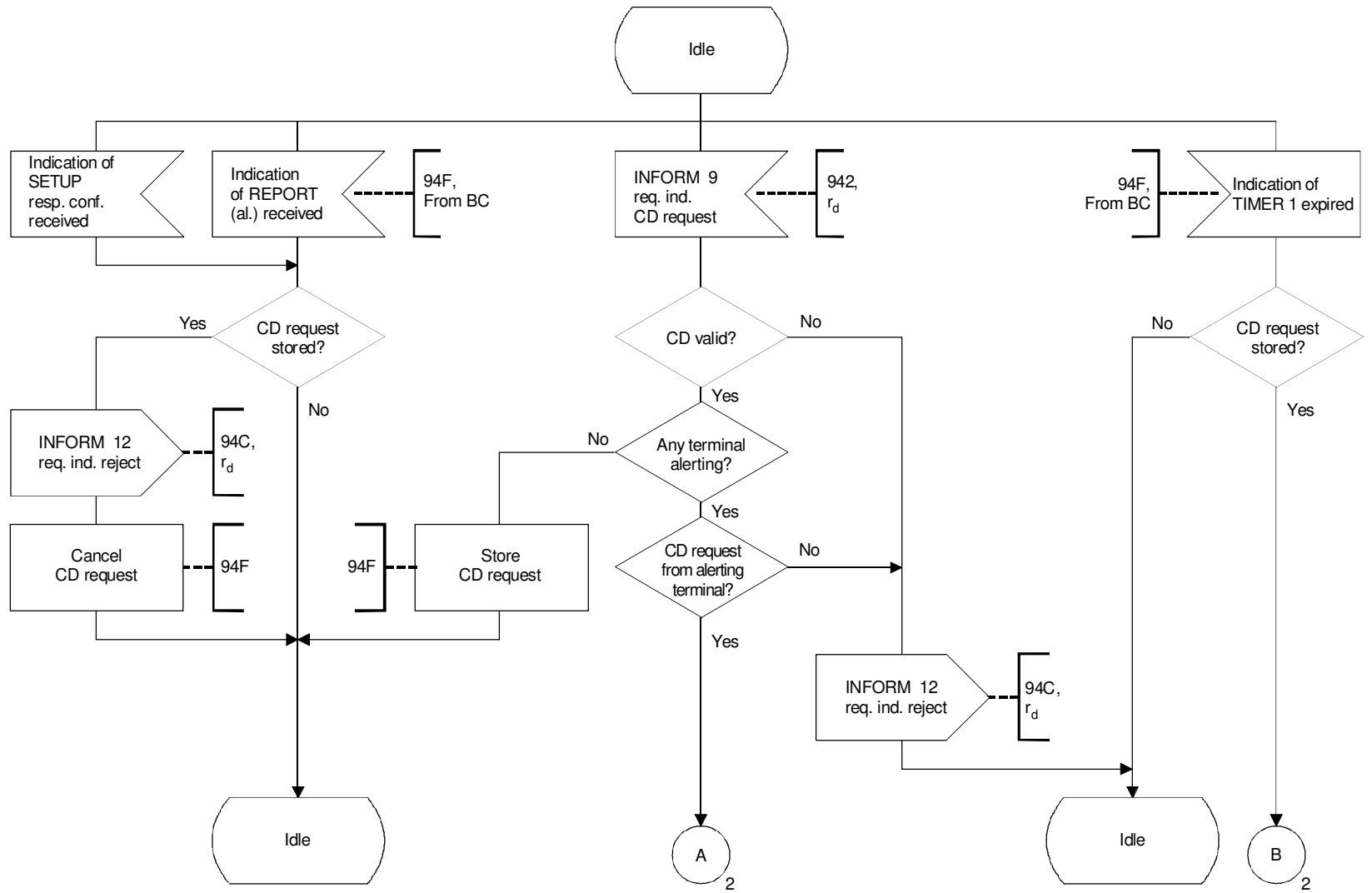

T1133890-91/d54

FIGURE 3-12/Q.82 (sheet 1 of 3)
 Functional entity FE4 call deflection

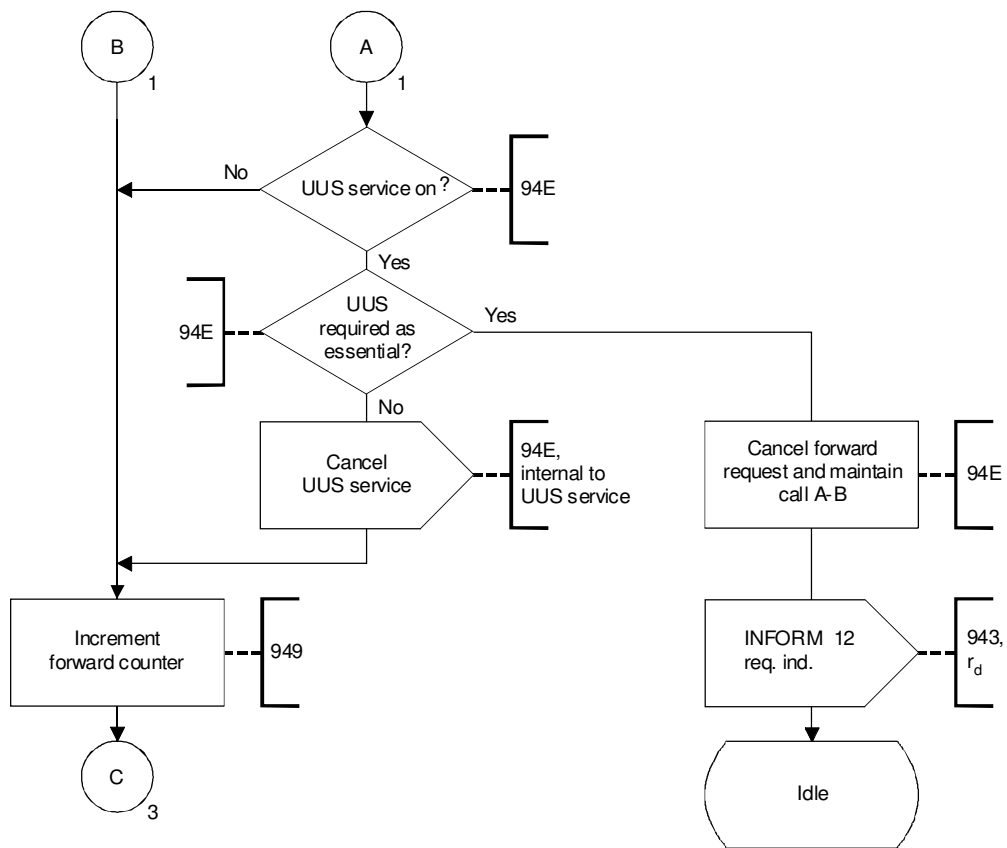

T1 133900-91/d55

FIGURE 3-12/Q.82 (sheet 2 of 3)
Functional entity FE4 call deflection

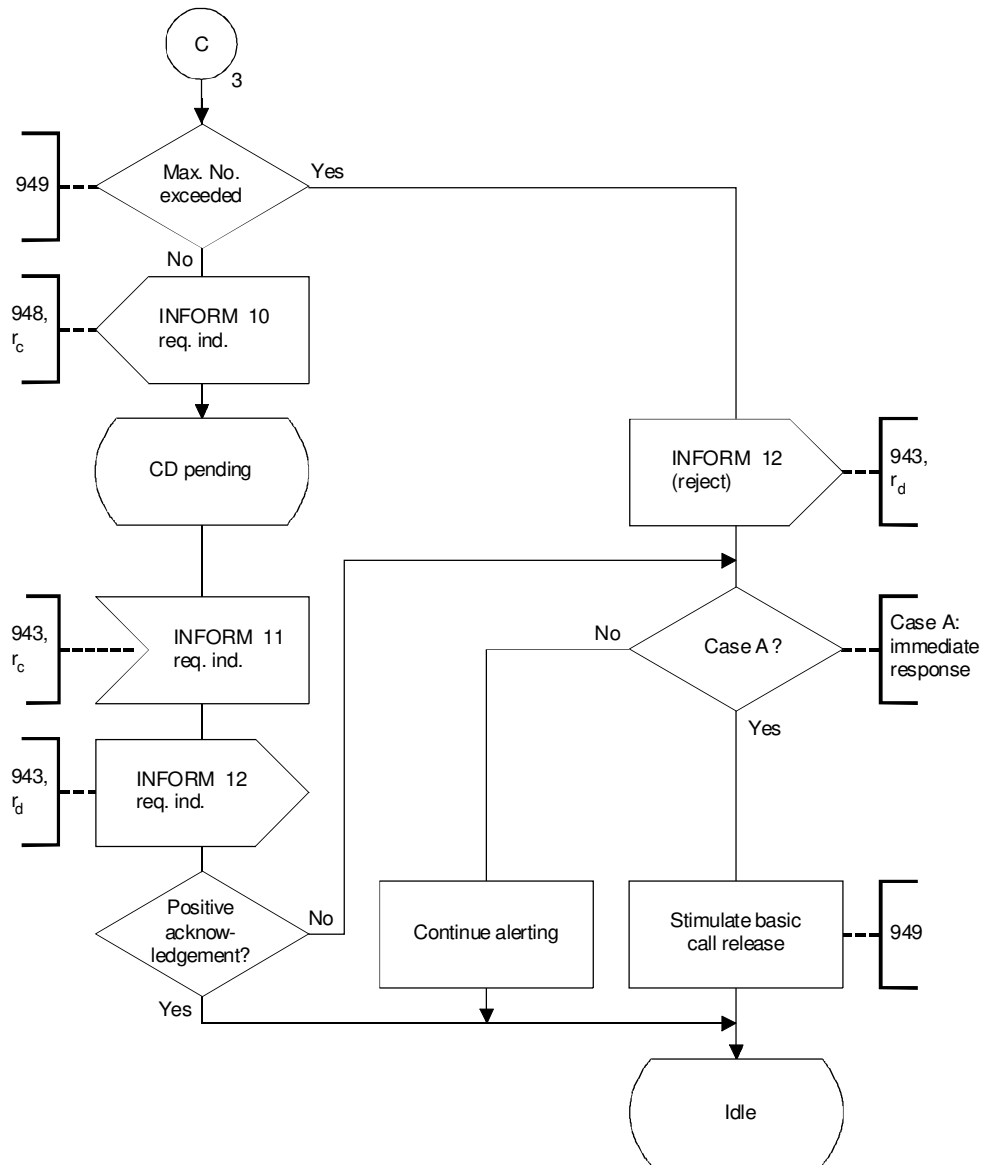

T1144310-92/d56

FIGURE 3-12/Q.82 (sheet 3 of 3)
Functional entity FE4 call deflection

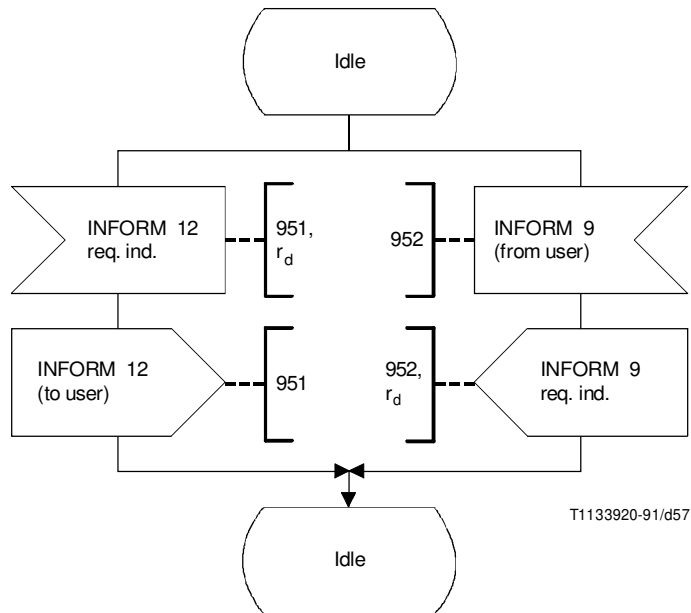
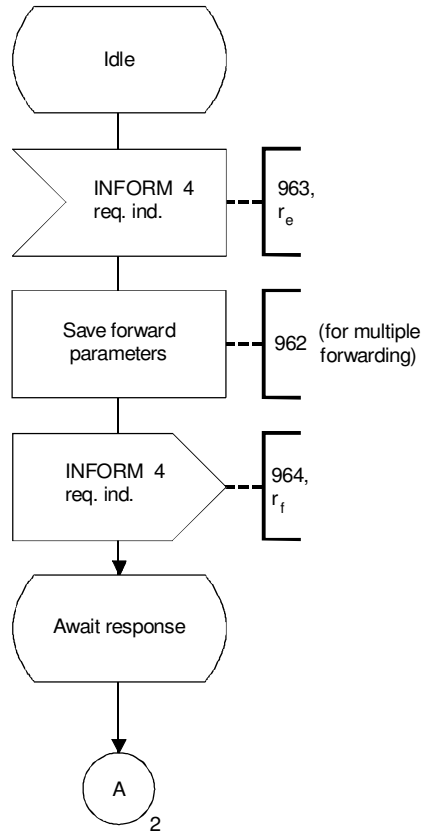
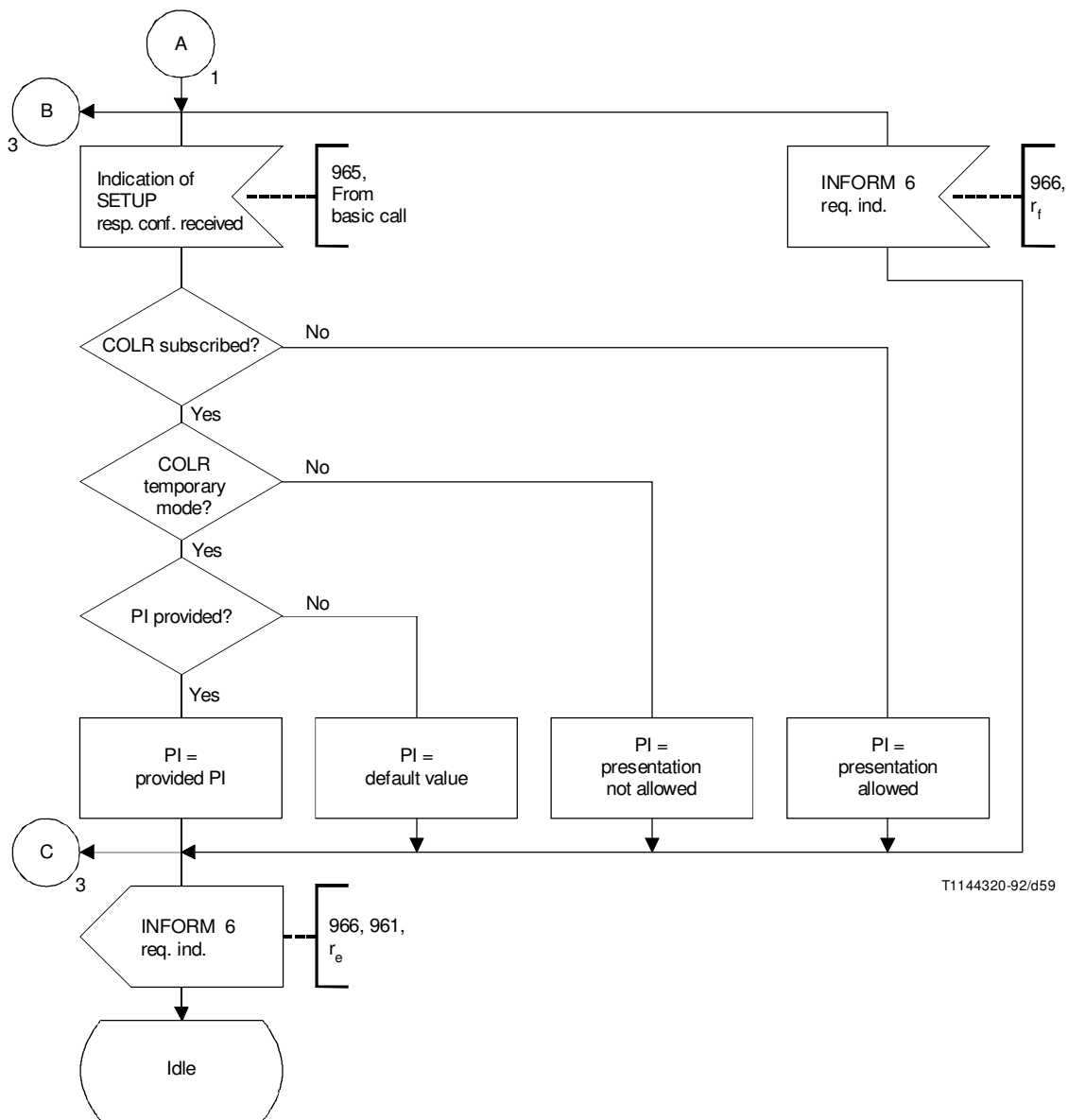

FIGURE 3-13/Q.82
Functional entity FE5 call deflection



T1133930-91/d58

FIGURE 3-14/Q.82 (sheet 1 of 3)
Functional entity FE6 call deflection



T1144320-92/d59

FIGURE 3-14/Q.82 (sheet 2 of 3)
Functional entity FE6 call deflection

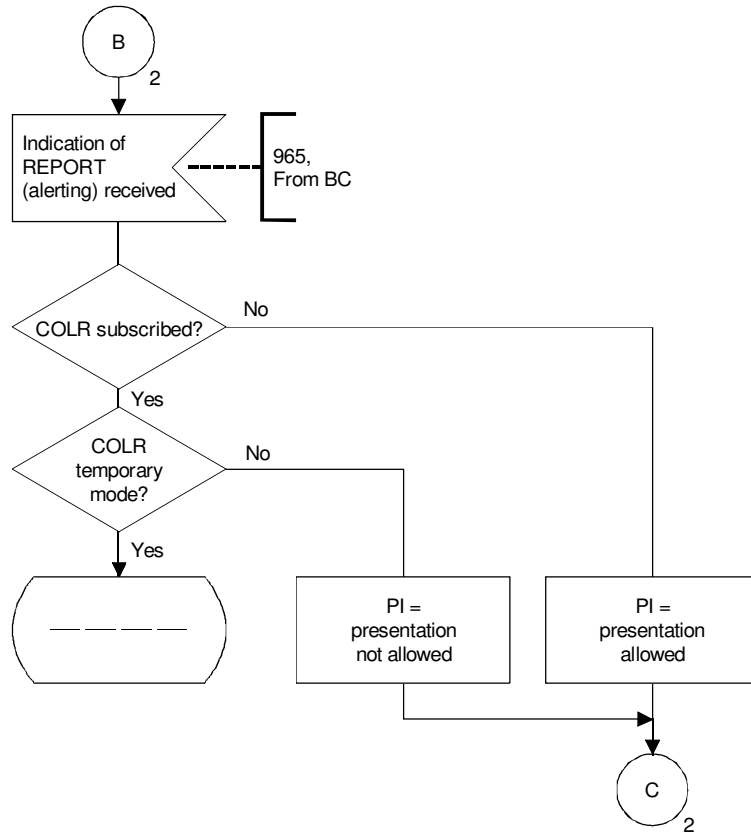

T1133950-91/d60

NOTE – The PI shall be determined by considering the interactions with COLR Supplementary Service and the Basic Service

FIGURE 3-14/Q.82 (sheet 3 of 3)
Functional entity FE6 call deflection

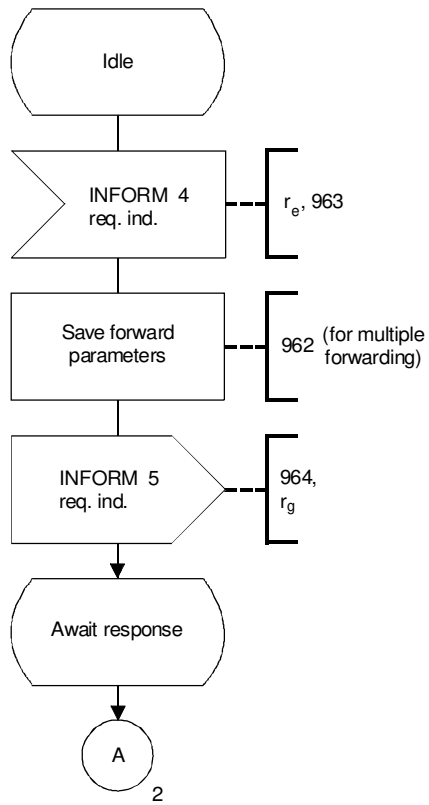

T11 33960-91/d61

FIGURE 3-15/Q.82 (sheet 1 of 3)
Functional entity FE7 call deflection

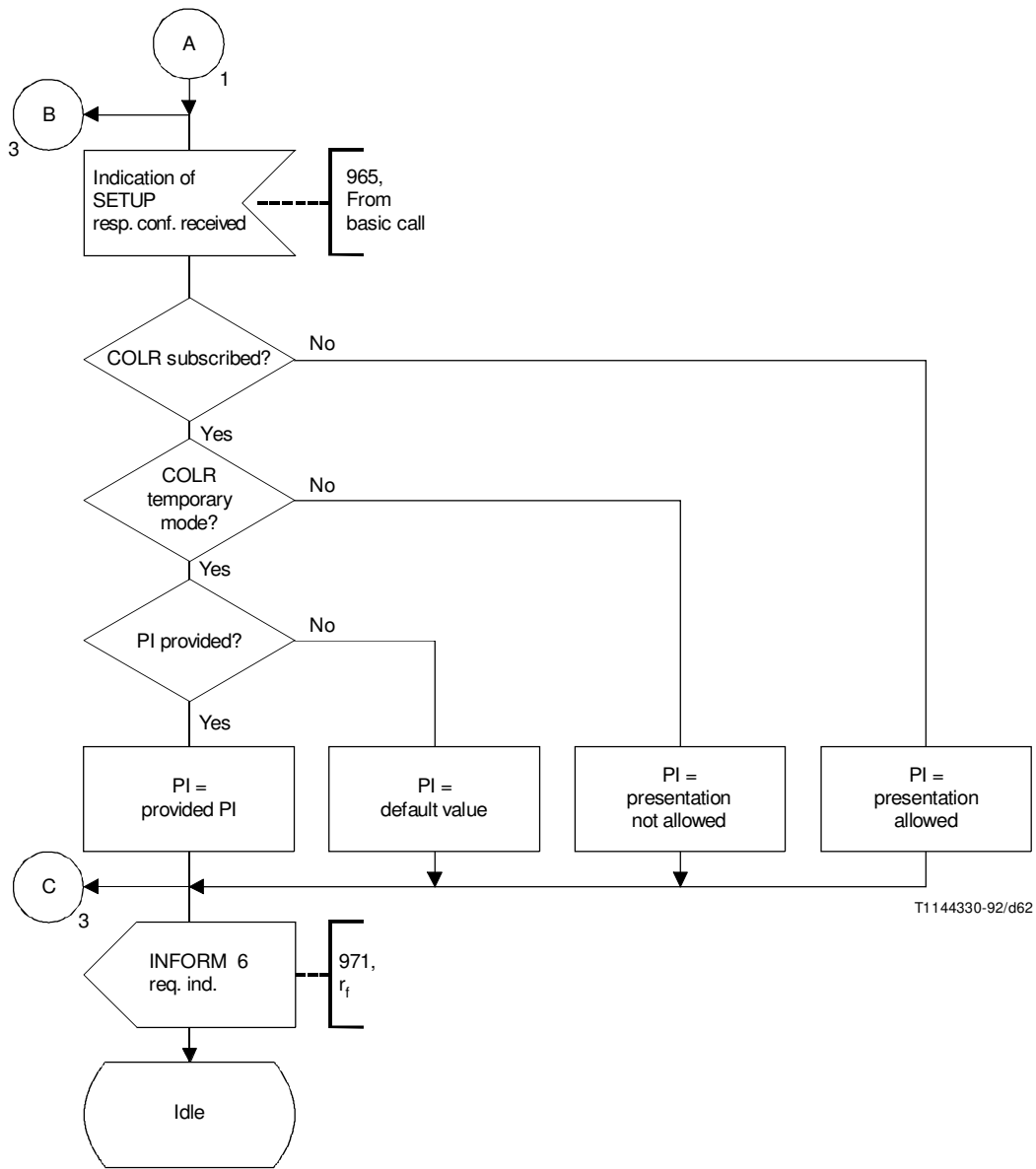
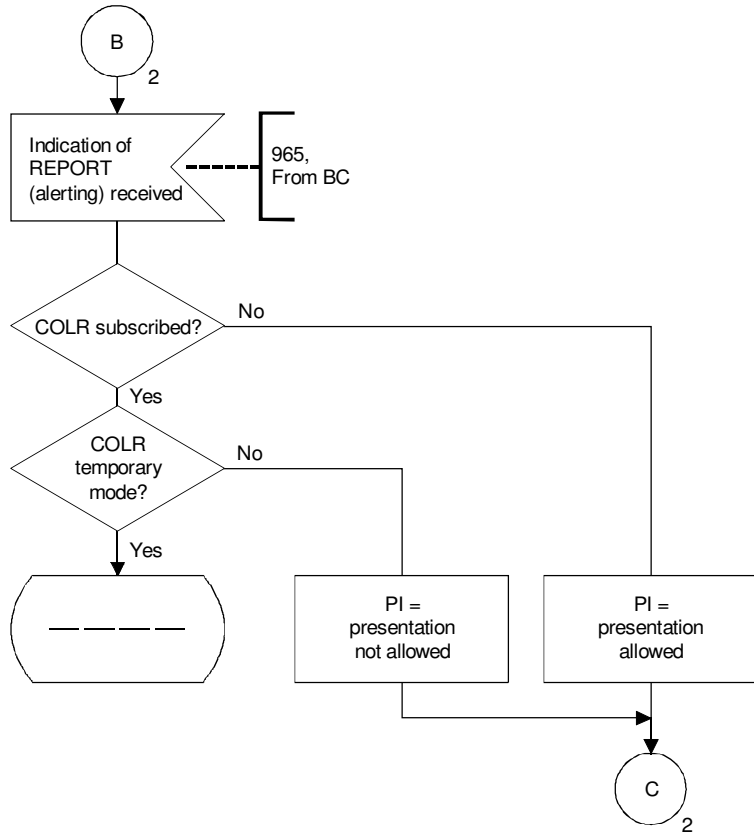

FIGURE 3-15/Q.82 (sheet 2 of 3)

Functional entity FE7 call deflection



T1133980-91/d63

NOTE – The PI shall be determined by considering the interactions with COLR Supplementary Service and the Basic Service.

FIGURE 3-15/Q.82 (sheet 3 of 3)
Functional entity FE7 call deflection

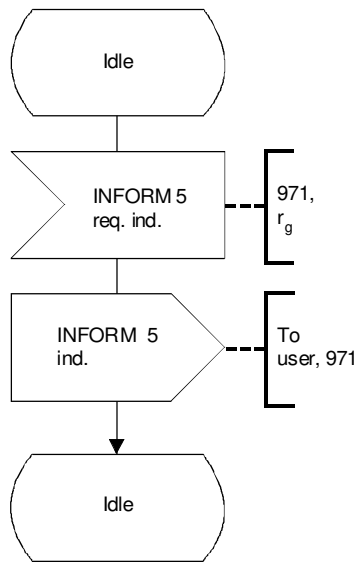

T11 24340-90/d64

FIGURE 3-16/Q.82
Functional entity FE7 call diversion

3.9 Functional entity actions

In the following subclauses the actions specific for the supplementary service call forwarding at the different functional entities are described.

Notification of diversion of the calling user may be provided as a network provider option. If provided by the network, the network shall support the functional entity actions/information flows necessary for the “calling user receives notification that his call has been diverted” subscription option.

If not provided by the network, the network will not support the functional entity actions/information flows necessary for the “calling user receives notification that his call has been diverted” subscription option.

3.9.1 Functional entity actions for FE1

911: Receive indications related to the service from FE2 and present them to the calling user.

3.9.2 Functional entity actions for FE2

921: Receive INFORM 1.

Delete old DTN if already saved.

Save new DTN (when available).

Save NSO, if it is the first or a subsequent more restrictive NSO.

922: Send INFORM 2 to FE1 if allowed.

923: Receive INFORM 6 and send INFORM 7 to FE1 if allowed.

3.9.3 Functional entity actions for FE3

- 931: Send INFORM 1 to FE2.
- 932: Receive INFORM 10 (deflection request) including all necessary parameters from FE4.
- 933: Stimulate release procedures for the leg towards the served user.
- 934: Stimulate basic call set-up towards the deflected-to user.
- 935: Decide whether deflection is allowed and valid.
- 936: Insert stored parameters (FEA 931) into SETUP req.ind and INFORM 4, send INFORM 4 with all necessary information to FE6.
- 937: Receive indications from the basic call of REPORT (alerting), SETUP resp.conf. or RELEASE req.ind. detected on the leg towards the deflected-to user.
- 938: Send INFORM 11 (result of deflection request) to FE4.
- 939:
- 930: Receive INFORM 6 from FE6 and send it to FE2.
- 93A: Receive indication of SETUP req.ind. from BASIC Call and store calling party number and restriction indicator.

3.9.4 Functional entity actions for FE4

- 941: Wait for expiry of BC Timer 1.
- 942: Receive INFORM 9 (call deflection request) from FE5.
- 943: Receive INFORM 11 and determine the success or failure of the deflection request.
- 944: Detect release of the served user.
- 945: Validation of call deflection request.
- 946: Receive necessary parameters from FE6 (internal) in case of multiple forwarding (not described in the flows and SDLs).
- 947: Run periodic timers specific to the service.
- 948: Determine parameters for INFORM 10 and send INFORM 10 to FE3.
- 949: Increment forwarding counter and when the service call count limit is exceeded
 - Case A (immediate CD request):
stimulate release procedures with the reason:
“Supplementary Service Incompatibility”
 - Case B (CD request during alerting):
return to Basic Call and continue alerting served user.
- 94C: Send INFORM 12 to FE5.
- 94F: Determine preconditions for CD invocation.

3.9.5 Functional entity actions for FE5

- 951: Receive indications related to the service from FE4 and present them to the served user.
- 952: Send INFORM 9 (Deflection Request) with new destination address to FE4.

3.9.6 Functional entity actions for FE6

- 961: Send INFORM 6 to FE3.
(This FEA is only required when the “PI” is determined in FE6.)
- 962:
- 963: Receive INFORM 4 from FE3, store
 - last forwarding number + restriction indicator
 - originally called number + restriction indicator

- 964: Send INFORM 4 to FE7,
restrict, if required, originally called number and/or last forwarding number.
- 965: Receive indication from the Basic Call of receipt of REPORT (alerting) req.ind. or SETUP resp.conf. and determine “PI” by interaction between the Basic Service, the Call Diversion and the COLR supplementary service.

(This FEA is only required when COLR is provided across the entire access.)
- 966: Relay any received INFORM 6.
- 967: Pass stored parameters to new FE3 (internal) when multiple forwarding occurs (not described in the SDL).

3.9.7 Functional entity actions for FE7

- 971: Send INFORM 6 to FE6.
- 972: Save forwarding parameters for use in next FE4 (internal) when multiple forwardings apply (not described in the flows and SDLs).
- 973: Receive INFORM 4 from FE8.
- 974: Send INFORM 5 to FE8.
- 975: Receive indication from the Basic Call of receipt of SETUP resp.conf. and determine “PI” by interaction between the Basic Service, the Call Diversion and the COLR supplementary service.

3.9.8 Functional entity actions for FE8

- 981: Receive indications related to the service from FE6 and present them to the called user.

3.10 Allocation of functional entities to physical locations

The possible physical locations of functional entities are shown in Table 3-14.

TABLE 3-14/Q.82
Scenarios for call deflection

	A Party		B1 Party			C Party		
	FE1	FE2	FE3	FE4	FE5	FE6	FE7	FE8
Scenario 1	TE	LE	LE		TE	LE		TE
2	PNX	LE	LE		TE	LE		TE
3	TE	LE	PNX		TE	LE		TE
4	TE	LE	LE		TE	LE	PNX	TE
5	PNX	LE	LE		TE	LE	PNX	TE
7	TE	LE	PNX		TE	LE	PNX	TE
8	TE	LE	LE	PNX	TE	LE		TE
9	PNX	LE	LE	PNX	TE	LE		TE
10	TE	LE	LE	PNX	TE	LE	PNX	TE
11	PNX	LE	LE	PNX	TE	LE	PNX	TE

NOTES

1 The network provider may limit the number of calls simultaneously diverted from a particular access.

2 The provision of partial rerouting is a public network provider option. In networks which provide partial rerouting, PNXs may operate scenarios 8, 9, 10 and 11.

Annex A

(to Clause 3 of Recommendation Q.82)

Multiple diversion address handling

(This annex forms an integral part of this Recommendation)

(See Annex A to Clause 2 on this Recommendation.)