



INTERNATIONAL TELECOMMUNICATION UNION

**ITU-T**

TELECOMMUNICATION  
STANDARDIZATION SECTOR  
OF ITU

**Q.764**

(03/93)

**SPECIFICATIONS OF  
SIGNALLING SYSTEM No. 7**

---

**SIGNALLING SYSTEM No. 7 –  
ISDN USER PART SIGNALLING  
PROCEDURES**

**ITU-T Recommendation Q.764**

(Previously “CCITT Recommendation”)

---

## FOREWORD

The ITU Telecommunication Standardization Sector (ITU-T) is a permanent organ of the International Telecommunication Union. The ITU-T is responsible for studying technical, operating and tariff questions and issuing Recommendations on them with a view to standardizing telecommunications on a worldwide basis.

The World Telecommunication Standardization Conference (WTSC), which meets every four years, established the topics for study by the ITU-T Study Groups which, in their turn, produce Recommendations on these topics.

ITU-T Recommendation Q.764 was revised by the ITU-T Study Group XI (1988-1993) and was approved by the WTSC (Helsinki, March 1-12, 1993).

---

## NOTES

1 As a consequence of a reform process within the International Telecommunication Union (ITU), the CCITT ceased to exist as of 28 February 1993. In its place, the ITU Telecommunication Standardization Sector (ITU-T) was created as of 1 March 1993. Similarly, in this reform process, the CCIR and the IFRB have been replaced by the Radiocommunication Sector.

In order not to delay publication of this Recommendation, no change has been made in the text to references containing the acronyms "CCITT, CCIR or IFRB" or their associated entities such as Plenary Assembly, Secretariat, etc. Future editions of this Recommendation will contain the proper terminology related to the new ITU structure.

2 In this Recommendation, the expression "Administration" is used for conciseness to indicate both a telecommunication administration and a recognized operating agency.

© ITU 1994

All rights reserved. No part of this publication may be reproduced or utilized in any form or by any means, electronic or mechanical, including photocopying and microfilm, without permission in writing from the ITU.

## CONTENTS

|   | <i>Page</i> |
|---|-------------|
| 1 General.....  | 1           |
| 2 Basic call control and signalling procedures.....   | 1           |
| 2.1 Successful call set-up .....  | 1           |
| 2.2 Unsuccessful call set-up .....  | 19          |
| 2.3 Normal call release .....   | 20          |
| 2.4 Suspend, resume .....   | 22          |
| 2.5 Signalling procedures for connection type allowing fallback .....   | 23          |
| 2.6 Propagation delay determination procedure.....  | 26          |
| 2.7 Echo control procedure .....  | 28          |
| 2.8 Network features.....   | 43          |
| 2.9 Abnormal conditions.....  | 48          |
| 2.10 ISDN User Part signalling congestion control .....   | 63          |
| 2.11 Automatic congestion control.....  | 63          |
| 2.12 Unequipped circuit identification code message (national use) .....  | 64          |
| 2.13 ISDN User Part availability control.....   | 64          |
| 2.14 MTP Pause/Resume .....   | 65          |
| 2.15 Overlength messages.....   | 65          |
| Annex A.....  | 66          |
| Annex B – Figures on basic call control signalling procedures.....  | 70          |
| Annex C – Examples of echo control signalling procedures .....  | 74          |
| C.1 Echo control equipment in all exchanges .....   | 74          |
| C.2 Multiple forwardings .....  | 74          |
| C.3 Echo control equipment is not available in all exchanges .....  | 74          |
| C.4 Echo control equipment is not available in all exchanges .....  | 75          |
| C.5 Interworking with signalling systems not supporting the echo control procedure in the preceding network.....  | 75          |
| C.6 Interworking with signalling systems not supporting the echo control procedure in the succeeding network..... | 75          |
| C.7 Procedures after address complete – backward direction.....   | 75          |
| C.8 Procedures after address complete – forward direction .....   | 82          |
| Annex D – Examples of signalling procedures for connection type allowing fallback.....                            | 82          |
| Annex E – Test calls.....   | 85          |
| E.1 Called number for test calls.....   | 85          |
| E.2 Accounting of test calls .....  | 85          |
| Annex F – Cause values.....   | 86          |
| Annex G – Start up procedures.....  | 86          |
| G.1 Initial procedure for putting the first group of circuits into service .....                                  | 87          |
| G.2 Initial procedure for putting additional circuits into service.....   | 87          |
| G.3 Test procedures.....  | 87          |



**SIGNALLING SYSTEM No. 7 –  
ISDN USER PART SIGNALLING PROCEDURES**

*(Málaga-Torremolinos 1984; modified at Helsinki, 1993)*

**1 General**

This Recommendation describes the ISDN-User Part signalling procedures for the set-up and clear down of national and international ISDN connections. Actions common for all types of exchanges are described only once. Different or additional actions required in an exchange are specified in a separate subclause applicable to that type of exchange.

The procedures specified in clause 2 relate to basic call (i.e. calls not involving supplementary services).

Recommendation Q.761 provides an overview of the signalling capabilities of the complete ISDN-User Part (both basic and supplementary services).

NOTE – In international operation the use of en-bloc or overlap signalling is based on bilateral agreements.

**2 Basic call control and signalling procedures**

Figures B.1 to B.4 show the ISDN call set-up sequences which are described below.

**2.1 Successful call set-up**

**2.1.1 Forward address signalling – En bloc operation**

**2.1.1.1 Actions required at the originating exchange**

a) *Circuit selection*

When the originating gateway exchange has received the complete selection information from the calling party, and has determined that the call is to be routed to another exchange, selection of a suitable, free, inter-exchange circuit takes place and an initial address message is sent to the succeeding exchange.

Appropriate routing information is either stored at the originating exchange or at a remote database to which a request may be made.

The selection of the route will depend on the called party number, connection type required and the network signalling capability required. This selection process may be performed at the exchange or with the assistance of the remote database.

In addition, in the case of a subscriber with digital access, the set-up message contains bearer capability information which is analyzed by the originating exchange to determine the correct connection type and network signalling capability. The bearer capability information will be mapped into the user service information parameter of the initial address message. The high layer capability information will be mapped into the user teleservice information parameter of the initial address message. The information received from the access interface is used to set the value of the transmission medium requirement parameter.

The connection types allowed are:

- speech;
- 3.1 kHz audio;
- 64 kbit/s unrestricted;
- 64 kbit/s unrestricted preferred;
- 2 × 64 kbit/s unrestricted;           multirate connection type
- 384 kbit/s unrestricted;           multirate connection type
- 1536 kbit/s unrestricted;           multirate connection type
- 1920 kbit/s unrestricted;           multirate connection type.

The network signalling capabilities allowed are:

- ISDN-User Part preferred;
- ISDN-User Part required;
- ISDN-User Part not required (any signalling system).

The information used to determine the routing of the call by the originating exchange will be included in the initial address message (as transmission medium requirement and forward call indicators) to enable correct routing at intermediate exchanges. The initial address message conveys implicitly the meaning that the indicated circuit has been seized.

b) *Address information sending sequence*

The sending sequence of address information on international calls will be the country code followed by the national (significant) number. On national connections, the address information may be the subscriber number or the national (significant) number as required by the Administration concerned. For calls to international operator positions (Code 11 and Code 12) refer to Recommendation Q.107.

The end-of-pulsing (ST) signal will be used when ever the originating exchange is in a position to know by digit analysis that the final digit has been sent.

c) *Initial address message*

The initial address message in principle contains all the information that is required to route the call to the destination exchange and connect the call to the called party.

If the initial address message would exceed the 272 octet limit for Message Transfer Part transfer, it shall be segmented by use of the segmentation message; see 2.1.12.

All initial address messages will include a protocol control indicator (in the forward call indicator parameter) and a transmission medium requirement parameter.

The originating exchange will set the parameters in the protocol control indicator and in the ISDN-User Part preference indicator to indicate:

- i) the type of end-to-end method that can be accommodated (see Recommendation Q.730);
- ii) the availability of Signalling System No. 7 signalling;
- iii) the use of the ISDN-User Part;
- iv) network signalling capability required, e.g. ISDN-User Part required all the way.

The ISDN-User Part preference indicator is set according to the bearer service, teleservice and supplementary service(s) requested. The exact setting depends on the service demand conditions and may be different depending on individual cases. In principle, if the service demand requires ISDN-User Part to be essential then the indicator is set to “required”, if the service required is optional but preferred it is set to “preferred”, otherwise it is set to “not required”. The indicator is set to either “required” or “preferred”, or “not required”, according to the most stringent condition required by one or more of the parameters in the initial address message.

The nature of connection indicators are set appropriately based on the characteristics of the selected outgoing circuit.

The transmission medium requirement parameter contains the connection type required information, e.g. 3.1 kHz audio.

The propagation delay counter is included according to 2.6.

The originating exchange may also include in the initial address message:

- i) a call reference (including the point code of the originating exchange) to enable the destination exchange to establish an end-to-end connection (see Recommendation Q.730);
- ii) the calling party number if this is to be passed forward without being requested. The calling party number could contain Code 11 or 12 if the call is from an international operator;
- iii) an SCCP connection request parameter (see Recommendation Q.730); and
- iv) other information related to supplementary services and network utilities.

The initial address message can contain an access transport parameter.

d) *Completion of transmission path*

Through connection of the transmission path will be completed in the backward direction (the transmission path is completed in the forward direction on receipt of a connect or answer message) at the originating exchange immediately after the sending of the initial address message, except in those cases where conditions on the outgoing circuit prevent it (see 7/Q.724).

It is also acceptable that on speech or 3.1 kHz audio calls, through-connection of the transmission path will be completed in both directions immediately after the initial address message has been sent, except in those cases where conditions on the outgoing circuit prevent it (see 7/Q.724).

e) *Network protection timer*

When the originating exchange has sent the initial address message, the awaiting address complete timer (T7) is started. If timer (T7) expires, the connection is released and an indication is returned to the calling subscriber.

### **2.1.1.2 Actions required at an intermediate national exchange**

a) *Circuit selection*

An intermediate national exchange, on receipt of an initial address message will analyze the called party number and the other routing information [see 2.1.1.1 a)] to determine the routing of the call. If the intermediate national exchange can route the call using the connection type specified in the transmission medium requirement parameter, a free inter-exchange circuit is seized and an initial address message is sent to the succeeding exchange. Within a network if the intermediate national exchange does not route the call using just the connection type specified in the transmission medium requirement parameter, the exchange may also examine the user service information containing the bearer capability information and/or the user teleservice information containing the high layer capability information, if available, to determine if a suitable route can be selected. In this case if a new connection type is provided the transmission medium requirement parameter is modified to the new connection type.

b) *Parameters in the initial address message*

An intermediate national exchange may modify signalling information received from the preceding exchange according to the capabilities used on the outgoing route. Signalling information that may be changed are nature of connection indicator and propagation delay counter. Other signalling information is passed on transparently, e.g. the access transport parameter, user service information, etc.

The satellite indicator in the nature of connection parameter should be incremented if the selected outgoing circuit is a satellite circuit. Otherwise, the indicator is passed on unchanged.

c) *Completion of transmission path*

Through-connection of the transmission path in both directions will be completed at an intermediate national exchange immediately after the initial address message has been sent, except in those cases where conditions on the outgoing circuit prevent it (see 7/Q.724).

### **2.1.1.3 Actions required at an outgoing international exchange**

a) *Circuit selection*

An outgoing international exchange, on receipt of an initial address message will analyze the called party number and the other routing information [see 2.1.1.1 a)] to determine the routing of the call. If the outgoing international exchange can route the call using the connection type specified in the transmission medium requirement parameter, a free inter-exchange circuit is seized and an initial address message is sent to the succeeding exchange.

If the outgoing international exchange can not trust that the transmission medium requirement value received from the national network reflects the minimum value of the information transfer susceptance, then the transmission medium requirement value may be modified according to the contents of the information transfer capability and information transfer rate fields of the user service information parameter (if available).

The outgoing international exchange must ensure that the transmission medium requirement parameter is set according to the service requested by the customer (see Recommendation E.172). More specifically this parameter is carried unchanged within the international network.

b) *Parameters in the initial address message*

An outgoing international exchange may modify signalling information received from the preceding exchange according to the capabilities used on the outgoing route. Signalling information that may be changed are nature of connection indicator and propagation delay counter; the most significant digits in the called party number may be amended or omitted (country code is removed at the last exchange before the incoming international exchange). Other signalling information is passed on transparently, e.g. the access transport parameter, user service information, etc.

If the outgoing international exchange belongs to a country using  $\mu$ -law PCM encoding nationally and the transmission medium requirement indicates speech or 3.1 kHz audio then the user information layer 1 protocol identification field of the user service information parameter must be checked, if it indicates "Recommendation G.711  $\mu$ -law" this must be changed to "Recommendation G.711 A-law" and a  $\mu$ -law to A-law convertor must be enabled.

The satellite indicator in the nature of connection parameter should be incremented if the selected outgoing circuit is a satellite circuit. Otherwise, the indicator is passed on unchanged.

The outgoing international gateway exchange should include the originating ISC point code parameter in the initial address message. This information is used for statistical purposes, e.g. accumulation of the number of incoming calls on an originating international switching center basis.

If a location number parameter is received, the nature of address indicator is checked. If the nature of address indicator is set to "international number" then the parameter is passed unchanged, otherwise the number is modified to the international number format and the nature of address is set to "international number" before being passed.

The end of pulsing (ST) signal will be used when ever the outgoing exchange is in a position to know by digit analysis that the final digit has been sent.

c) *Completion of transmission path*

Through-connection of the transmission path in both directions will be completed at an outgoing international exchange immediately after the initial address message has been sent, except in those cases where conditions on the outgoing circuit prevent it (see 7/Q.724).

d) *Network protection timer*

When an outgoing international exchange has sent the initial address message, the awaiting address complete timer (T7) is started. If timer (T7) expires, the connection is released and an indication is returned to the calling subscriber.

#### **2.1.1.4 Actions required at an intermediate international exchange**

a) *Circuit selection*

An intermediate international exchange, on receipt of an initial address message will analyze the called party number and the other routing information [see 2.1.1.1 a)] to determine the routing of the call. If the intermediate international exchange can route the call using the connection type specified in the transmission medium requirement parameter, a free inter-exchange circuit is seized and an initial address message is sent to the succeeding exchange.

b) *Parameters in the initial address message*

An intermediate international exchange may modify signalling information received from the preceding exchange according to the capabilities used on the outgoing route. Signalling information that may be changed are nature of connection indicator and propagation delay counter; the most significant digits in the called party number may be amended or omitted (country code is removed at the last exchange before the incoming international exchange). Other signalling information is passed on transparently, e.g. the access transport parameter, user service information, etc.

The satellite indicator in the nature of connection parameter should be incremented if the selected outgoing circuit is a satellite circuit. Otherwise, the indicator is passed on unchanged.

c) *Completion of transmission path*

Through-connection of the transmission path in both directions will be completed at an intermediate international exchange immediately after the initial address message has been sent, except in those cases where conditions on the outgoing circuit prevent it (see 7/Q.724).



d) *Network protection timer*

When an intermediate international exchange has sent the initial address message, the awaiting address complete timer (T7) is started. If timer (T7) expires, the connection is released and an indication is returned to the calling subscriber.

#### 2.1.1.5 Actions required at an incoming international exchange

a) *Circuit selection*

An incoming international exchange, on receipt of an initial address message will analyze the called party number and the other routing information [see 2.1.1.1 a)] to determine the routing of the call. If the incoming international exchange can route the call using the connection type specified in the transmission medium requirement parameter, a free inter-exchange circuit is seized and an initial address message is sent to the succeeding exchange.

b) *Parameters in the initial address message*

An incoming international exchange may modify signalling information received from the preceding exchange according to the capabilities used on the outgoing route. Signalling information that may be changed are nature of connection indicator and propagation delay counter. Other signalling information is passed on transparently, e.g. the access transport parameter, user service information, etc.

The satellite indicator in the nature of connection parameter should be incremented if the selected outgoing circuit is a satellite circuit. Otherwise, the indicator is passed on unchanged.

If the incoming international exchange belongs to a country using  $\mu$ -law PCM encoding nationally and the transmission medium requirement indicates speech or 3.1 kHz audio then the user information layer 1 protocol identification field of the user service information parameter must be checked, if it indicates "Recommendation G.711 A-law" this must be changed to "Recommendation G.711  $\mu$ -law" and a  $\mu$ -law to A-law convertor must be enabled.

The incoming international gateway exchange should delete the originating ISC point code parameter from the initial address message and set up a connection to the national network. This information is used for statistical purposes, e.g. accumulation of the number of incoming calls on an originating international switching center basis.

c) *Completion of transmission path*

Through-connection of the transmission path in both directions will be completed at an incoming international exchange immediately after the initial address message has been sent, except in those cases where conditions on the outgoing circuit prevent it (see 7/Q.724).

d) *Network protection timer*

When an incoming international exchange has sent the initial address message, the awaiting address complete timer (T7) is started. If timer (T7) expires, the connection is released and an indication is returned to the calling subscriber.

#### 2.1.1.6 Actions required at the destination exchange

a) *Selection of called party*

Upon receipt of an initial address message, the destination exchange will analyze the called party number to determine to which party the call should be connected. It will also check the called party's line condition and perform various checks to verify whether or not the connection is allowed. These checks will include correspondence of compatibility checks, e.g. checks associated with supplementary services.

In this case where the connection is allowed, the destination exchange will set up a connection to the called party. If a continuity check has to be performed on one or more of the circuits involved in a connection, setting up of the connection to the called party must be prevented until the continuity of such circuits has been verified.

b) *Segmented initial address message*

If the initial address message had been segmented by the use of the segmentation message, the remainder of the call set up information is awaited; see 2.1.12.

### 2.1.1.7 Called party number for operator calls

International gateways should support access to operators equipment as specified in Recommendation Q.101.

The sending sequence of specific forward address information to be sent for calls to operators (incoming, delay or particular delay operator) is shown below. The other parameters of the initial address message are coded as the ones for an automatic call initial address message (e.g. nature of connections indicator, transmission medium requirement, etc.).

#### 2.1.1.7.1 International transit operator call

i) Called party number:

nature of address indicator: "0000100" international number

address:

- country code: I1, I1I2, I1I2I3
- extra digit designating the incoming international exchange N1 (Note 1)
- access to operator's position: Code 11 or Code 12 or special number (Note 2)
- number of a particular position: x1(x2x3...)
- sending finished: ST

NOTES

1 The extra digit (N1) designating the incoming international exchange is used in cases where more than one incoming international exchange can be reached in the country of destination. The insertion of the extra digit is not mandatory (see Recommendation Q.107).

2 The incoming operator or the delay operator may be obtained by using a special number (see Recommendation Q.101).

ii) Calling party category:

- "00000001" operator, language French
- "00000010" operator, language English
- "00000011" operator, language German
- "00000100" operator, language Russian
- "00000101" operator, language Spanish

#### 2.1.1.7.2 International terminal operator call

i) Called party number:

nature of address indicator: "0000011" national (significant) number

address:

- extra digit designating the incoming international exchange N1 (Note 1 of 2.1.1.7.1)
- access to operator's position: Code 11 or Code 12 or special number (Note 2 of 2.1.1.7.1)
- number of a particular position: x1(x2x3...)
- sending finished: ST

ii) Calling party category:

- "00000001" operator, language French
- "00000010" operator, language English
- "00000011" operator, language German
- "00000100" operator, language Russian
- "00000101" operator, language Spanish

### 2.1.1.8 Called number for calls to testing and measuring devices

This subclause only describes the standard sending sequence of forward address information in the case of calls to testing and measuring devices.

i) Called party number:

nature of address indicator: "0000011" national (significant) number

address:

- access code for particular testing or measuring device: XY (as given in Recommendation Q.107).
- sending finished: ST

ii) Calling party category:

"00001101" test call

NOTE – The principles in Recommendation Q.107 are not always applicable to the international network.

### 2.1.2 Forward address signalling – Overlap operation

#### 2.1.2.1 Actions required at the originating exchange

a) *Circuit selection*

When the originating exchange has received sufficient information [see 2.1.2.1 c)] from the calling party to determine that the call is to be routed to another exchange, selection of a suitable, free, inter-exchange circuit takes place and an initial address message is sent to the succeeding exchange.

Appropriate routing information is either stored at the originating exchange or at a remote database to which a request may be made.

The selection of the route will depend on the called party number, connection type required and the network signalling capability required. This selection process may be performed at the exchange or with the assistance of a remote database.

In addition, in the case of a subscriber with digital access, the set-up message contains bearer capability information which is analyzed by the originating exchange to determine the correct connection type and network signalling capability. The bearer capability information will be mapped into the user service information parameter of the initial address message. The high layer capability information will be mapped into the user teleservice information parameter of the initial address message. The information received from the access interface is used to set the value of the transmission medium requirement parameter.

The connection types allowed are:

- speech;
- 3.1 kHz audio;
- 64 kbit/s unrestricted;
- 64 kbit/s unrestricted preferred;
- 2 × 64 kbit/s unrestricted;           multirate connection type
- 384 kbit/s unrestricted;            multirate connection type
- 1536 kbit/s unrestricted;          multirate connection type
- 1920 kbit/s unrestricted;          multirate connection type.

The network signalling capabilities allowed are:

- ISDN-User Part preferred;
- ISDN-User Part required;
- ISDN-User Part not required (any signalling system).

The information used to determine the routing of the call by the originating exchange will be included in the IAM (as transmission medium requirement and forward call indicators) to enable correct routing at intermediate exchanges. The initial address message conveys implicitly the meaning that the indicated circuit has been seized.

b) *Address information sending sequence*

The sending sequence of address information on international calls will be the country code followed by the national (significant) number. On national connections, the address information may be the subscriber number or the national (significant) number as required by the Administration concerned. For calls to international operator positions (Code 11 and Code 12) refer to Recommendation Q.107.

The end-of-pulsing (ST) signal will be used when ever the originating exchange is in a position to know by digit analysis that the final digit has been sent.

c) *Content of initial and subsequent address messages*

The initial and subsequent address messages in principle contain all of the information that is required to route the call to the destination exchange and connect the call to the called party. The contents of the initial address message is the same as described in 2.1.1.1 c). The only purpose of the subsequent address message is to carry further digits.

If the initial address message would exceed the 272 octet limit for Message Transfer Part transfer, it shall be segmented by use of the segmentation message; see 2.1.12.

Within national networks the address information contained within the initial address message may vary depending on the routing requirement within the network.

The remaining digits of the number may be sent in subsequent address messages containing one or several digits as they are received. Efficiency can be gained by grouping together as many digits as possible. However, to prevent an increase in post sending delay in those cases where overlap operation with subscribers' dialling is used, it may be desirable to send the last few digits individually.

The end-of-pulsing (ST) signal is always sent in the following situations:

- i) semi-automatic calls;
- ii) test calls; and
- iii) when the end-of-pulsing (ST) signal is received.

In automatic working, the end-of-pulsing (ST) signal will be sent whenever the originating exchange is in a position to know, by digit analysis, that the final digit has been sent. Digit analysis may consist of an examination of the country code and counting the maximum (or fixed) number of digits of the national number. In other cases, the end-of-pulsing signal is not sent and the end-of-address information is determined by the receipt of the address complete message or connect message from the incoming exchange.

d) *Completion of transmission path*

Through-connection of the transmission path in the backward direction (the transmission path is completed in the forward direction on receipt of connect or answer message) at the originating exchange will be completed except in the cases where conditions on the outgoing circuit prevent it (see 7/Q.724):

- i) immediately after the sending of the initial address message; or
- ii) when digit analysis or timer (T10), or receipt of the address complete message indicates that all digits have been received. It is also acceptable that on speech or 3.1 kHz audio calls, through connection of the transmission path will be completed in both directions immediately after the initial address message has been sent, except in the cases where conditions on the outgoing circuit prevent it (see 7/Q.724).

e) *Network protection timer*

Each time when the originating exchange has sent an address message, the awaiting address complete timer (T7) is started. If timer (T7) expires, the connection is released and an indication is sent to the calling subscriber.

### 2.1.2.2 Actions required at an intermediate national exchange

#### a) *Circuit selection*

An intermediate national exchange, on receipt of an initial address message, will analyze the digits available and the other routing information [see 2.1.2.1 a)] to determine the routing of the call. If the intermediate national exchange can route the call using the connection type specified in the transmission medium requirement parameter, a suitable free inter-exchange circuit is seized and an initial address message is sent to the succeeding exchange. If the number of digits in the called party number are not sufficient to route the call, the routing will be carried out when the intermediate national exchange has received additional digits in subsequent address message(s). Any address digits received in subsequent address messages during the circuit selection process may be included in this initial address message. Any subsequent address messages received after the initial address message has been sent, are forwarded to the succeeding exchange as subsequent address message(s).

Within the network if the intermediate national exchange does not route the call just using the connection type specified in the transmission medium requirement parameter, the exchange may also examine the user service information containing the bearer capability information and/or the user teleservice information containing the high layer capability information, if available, to determine if a suitable route can be selected. In this case the transmission medium requirement parameter is modified to the new connection type.

#### b) *Parameters in the initial address message*

An intermediate national exchange may modify signalling information received from the preceding exchange according to the capabilities used on the outgoing route. Signalling information that may be changed are nature of connection indicator and propagation delay counter. Other signalling information is passed on transparently, e.g. the access transport parameter, user service information, etc.

The satellite indicator in the nature of connection parameter should be incremented if the selected outgoing circuit is a satellite circuit. Otherwise, the indicator is passed on unchanged.

#### c) *Completion of transmission path*

Through-connection of the transmission path in both directions will be completed at an intermediate national exchange immediately after the initial address message has been sent, except in those cases where conditions on the outgoing circuit prevent it (see 7/Q.724).

### 2.1.2.3 Actions required at an outgoing international exchange

#### a) *Circuit selection*

An outgoing international exchange, on receipt of an initial address message, will analyze the digits available and the other routing information [see 2.1.2.1 a)] to determine the routing of the call. If the outgoing international exchange can route the call using the connection type specified in the transmission medium requirement parameter, a suitable free inter-exchange circuit is seized and an initial address message is sent to the succeeding exchange. All digits required for routing the call through the international network will be sent in the initial address message. On calls with a country code in the number (except in the case of calls to special operators), the initial address message will contain a minimum of 4 digits and should contain as many digits as are available. If the number of digits in the called party number is not sufficient to route the call, the routing will be carried out when the outgoing international exchange has received additional digits in subsequent address message(s). Any address digits received in subsequent address messages during the circuit selection process may be included in this initial address message. Any subsequent address messages received after the initial address message has been sent, are forwarded to the succeeding exchange as subsequent address message(s).

If the outgoing international exchange can not trust that the transmission medium requirement value received from the national network reflects the minimum value of the information transfer susceptance, then the transmission medium requirement value may be modified according to the contents of the information transfer capability and information transfer rate fields of the user service information parameter (if available).

The outgoing international exchange must ensure that the transmission medium requirement parameter is set according to the service requested by the customer (see Recommendation E.172). More specifically this parameter is carried unchanged within the international network.

b) *Parameters in the initial address message*

An outgoing international exchange may modify signalling information received from the preceding exchange according to the capabilities used on the outgoing route. Signalling information that may be changed are nature of connection indicator and propagation delay counter; the most significant digits in the called party number may be amended or omitted (country code is removed at the last exchange before the incoming international exchange). Other signalling information is passed on transparently, e.g. the access transport parameter, user service information, etc.

In automatic working, the end-of-pulsing (ST) signal will be sent whenever the outgoing international exchange is in a position to know, by digit analysis, that the final digit has been sent. Digit analysis may consist of an examination of the country code and counting the maximum (or fixed) number of digits of the national number. In other cases, the end-of-pulsing signal is not sent and the end-of-address information is determined by the receipt of the address complete message or connect message from the incoming exchange.

If the outgoing international exchange belongs to a country using  $\mu$ -law PCM encoding nationally and the transmission medium requirement indicates speech or 3.1 kHz audio then the user information layer 1 protocol identification field of the user service information parameter must be checked, if it indicates "Recommendation G.711  $\mu$ -law" this must be changed to "Recommendation G.711 A-law" and a  $\mu$ -law to A-law convertor must be enabled.

The satellite indicator in the nature of connection parameter should be incremented if the selected outgoing circuit is a satellite circuit. Otherwise, the indicator is passed on unchanged.

The outgoing international gateway exchange should include the originating ISC point code parameter in the initial address message. This information is used for statistical purposes, e.g. accumulation of the number of incoming calls on an originating international switching center basis.

c) *Completion of transmission path*

Through-connection of the transmission path in both directions will be completed at an outgoing international exchange immediately after the initial address message has been sent, except in those cases where conditions on the outgoing circuit prevent it (see 7/Q.724).

d) *Network protection timer*

Each time when an outgoing international exchange has sent an address message, the awaiting address complete timer (T7) is started. If timer (T7) expires, the connection is released and an indication is returned to the calling subscriber.

#### **2.1.2.4 Actions required at an intermediate international exchange**

a) *Circuit selection*

An intermediate international exchange, on receipt of an initial address message, will analyze the digits available and the other routing information [see 2.1.2.1 a)] to determine the routing of the call. If the intermediate international exchange can route the call using the connection type specified in the transmission medium requirement parameter, a suitable free inter-exchange circuit is seized and an initial address message is sent to the succeeding exchange. If the number of digits in the called party number are not sufficient to route the call, the routing will be carried out when the intermediate international exchange has received additional digits in subsequent address message(s). Any address digits received in subsequent address messages during the circuit selection process may be included in this initial address message. Any subsequent address messages received after the initial address message has been sent, are forwarded to the succeeding exchange as subsequent address message(s).

b) *Parameters in the initial address message*

An intermediate international exchange may modify signalling information received from the preceding exchange according to the capabilities used on the outgoing route. Signalling information that may be changed are nature of connection indicator and propagation delay counter; the most significant digits in the called party number may be amended or omitted (country code is removed at the last exchange before the incoming international exchange). Other signalling information is passed on transparently, e.g. the access transport parameter, user service information, etc.

The satellite indicator in the nature of connection parameter should be incremented if the selected outgoing circuit is a satellite circuit. Otherwise, the indicator is passed on unchanged.

c) *Completion of transmission path*

Through-connection of the transmission path in both directions will be completed at an intermediate international exchange immediately after the initial address message has been sent, except in those cases where conditions on the outgoing circuit prevent it (see 7/Q.724).

d) *Network protection timer*

Each time when an intermediate international exchange has sent an address message, the awaiting address complete timer (T7) is started. If timer (T7) expires, the connection is released and an indication is returned to the calling subscriber.

### 2.1.2.5 Actions required at an incoming international exchange

a) *Circuit selection*

An incoming international exchange, on receipt of an initial address message, will analyze the digits available and the other routing information [see 2.1.2.1 a)] to determine the routing of the call. If the incoming international exchange can route the call using the connection type specified in the transmission medium requirement parameter, a suitable free inter-exchange circuit is seized and an initial address message is sent to the succeeding exchange. If the number of digits in the called party number are not sufficient to route the call, the routing will be carried out when the incoming international exchange has received additional digits in subsequent address message(s). Any address digits received in subsequent address messages during the circuit selection process may be included in this initial address message. Any subsequent address messages received after the initial address message has been sent, are forwarded to the succeeding exchange as subsequent address message(s).

Selection of the outgoing national circuit normally can start at an incoming international exchange on receipt of the initial address message and signalling can proceed on the first national link.

b) *Parameters in the initial address message*

An incoming international exchange may modify signalling information received from the preceding exchange according to the capabilities used on the outgoing route. Signalling information that may be changed are nature of connection indicator and propagation delay counter. Other signalling information is passed on transparently, e.g. the access transport parameter, user service information, etc.

If the incoming international exchange belongs to a country using  $\mu$ -law PCM encoding nationally and the transmission medium requirement indicates speech or 3.1 kHz audio then the user information layer 1 protocol identification field of the user service information parameter must be checked, if it indicates "Recommendation G.711 A-law" this must be changed to "Recommendation G.711  $\mu$ -law" and a  $\mu$ -law to A-law convertor must be enabled.

The satellite indicator in the nature of connection parameter should be incremented if the selected outgoing circuit is a satellite circuit. Otherwise, the indicator is passed on unchanged.

Incoming international gateway exchanges may delete the originating ISC point code parameter in the initial address message and set up a connection to the national network. This information is used for statistical purposes, e.g. accumulation of the number of incoming calls on an originating international switching center basis.

c) *Completion of transmission path*

Through-connection of the transmission path in both directions will be completed at an incoming international exchange immediately after the initial address message has been sent, except in those cases where conditions on the outgoing circuit prevent it (see 7/Q.724).

d) *Network protection timer*

Each time when an incoming international exchange has sent an address message, the awaiting address complete timer (T7) is started. If timer (T7) expires, the connection is released and an indication is returned to the calling subscriber.

### **2.1.2.6 Actions required at the destination exchange**

#### a) *Selection of called party*

Upon the receipt of the sufficient called party number information the destination exchange will analyze the called party number to determine to which party the call should be connected. It will also check the called party's line condition and perform various checks, to verify whether or not the connection is allowed. These checks will include correspondence of compatibility checks, e.g. checks associated with supplementary services.

In the case where the connection is allowed, the destination exchange will set up a connection to the called party. If a continuity check has to be performed on one or more of the circuits involved in a connection, setting up of the connection to the called party must be prevented until the continuity of such circuits has been verified.

#### b) *Segmented initial address message*

If the initial address message had been segmented by the use of the segmentation message, the remainder of the call set up information is awaited; see 2.1.12.

### **2.1.2.7 Called party number for operator calls**

See 2.1.1.7.

### **2.1.2.8 Called number for calls to testing and measuring devices**

See 2.1.1.8.

### **2.1.3 Calling party number**

#### a) *International network*

The calling party number can only be included in the initial address message [see 2.1.1.1 c) and 2.1.2.1 c)].

#### b) *National networks*

The calling party number can either be included in the initial address message [see 2.1.1.1 c) and 2.1.2.1 c)] or requested by the destination exchange (see 2.1.6). If the calling party number is required at the destination exchange but is not included in the initial address message, the destination exchange may request the calling party number. The destination exchange will investigate the presence/absence of the calling party number parameter to determine whether a request is useful or not. Further it may be necessary to withhold the sending of the address complete message until the calling party number has been successfully delivered.

### **2.1.4 Address complete message or connect message**

If the address complete or connect message would exceed the 272 octet limit for Message Transfer Part transfer, it shall be segmented by use of the segmentation message; see 2.1.12.

#### **2.1.4.1 Actions required at the destination exchange**

- i) An address complete message will be sent from the destination exchange as soon as it has been determined that the complete called party number has been received, or an indication received from the called party that an inband tone is being connected (for this case see 2.1.5 and 2.2.4). However there is no direct mapping from alerting, received from the access signalling system, to address complete in the network. In the case that the continuity check is performed, the destination exchange will withhold sending the address complete message until a successful continuity indication has been received (see 7/Q.724).

Address complete is sent from the destination exchange in the following conditions:

- 1) In the case where the terminating access is non ISDN the following action takes place at the destination exchange:
  - a) In all cases an address complete message is sent as soon as it has been determined that the complete called party number has been received, and the destination exchange established that the subscriber is free. Indicators in the address complete message will be set to indicate:
    - call line status: "Subscriber free"
    - ISDN access indicator: "Non ISDN"



- b) In the case of a PBX an address complete message is sent as soon as it has been determined that the called party number has been received. Indicators in the address complete message will be set to indicate:
  - called line status: “No indication”
  - ISDN access indicator: “Non ISDN”
- 2) In the case where the terminating access is ISDN, the following conditions can apply:
  - a) If an indication that the address is complete or no status indication has been received from the ISDN access prior to the destination exchange determining that the complete called party number has been received, the indicators in the address complete message will be set as follows:
    - called line status: “No indication”
    - ISDN access indicator: “ISDN”

NOTE – In case a) the indication that the destination user is being alerted is transferred in a call progress message (see 2.1.5).
  - b) The destination exchange concludes from the receipt of an indication from the ISDN access that the complete called party number has been received. In this case the indicators in the address complete message will be set as follows:
    - called line status: “Subscriber free”
    - ISDN access indicator: “ISDN”
- ii) If a connect indication is received from the ISDN access under the following conditions:
  - no alerting indication received from the ISDN access; and
  - an address complete message has not yet been sent by the destination exchange,

a connect message is sent by the destination exchange. This connect message signifies both address complete and answer conditions. Indicators in the connect message will indicate:

  - called line status: “Subscriber free”
  - ISDN access indicator: “ISDN”

The destination exchange will through-connect before the connect message is sent.

Call history information is included in the connect message.

#### **2.1.4.2 Actions required at an intermediate national exchange**

Upon receipt of an address complete message an intermediate national exchange will send the corresponding address complete message to the preceding exchange, and if this is the exchange controlling charging, the awaiting answer timer T9 is started. If timer (T9) expires, the connection is released and an indication is sent to the calling subscriber.

If a connect message is received at an intermediate national exchange instead of an address complete message, a connect message will be sent to the preceding exchange.

#### **2.1.4.3 Actions required at an outgoing international exchange**

Upon receipt of an address complete message, the awaiting address complete timer (T7) is stopped and the awaiting answer timer (T9) is started. If timer (T9) expires, the connection is released and an indication is sent to the calling subscriber.

If the connect message is received, then the awaiting address complete timer (T7) is stopped.

See also 2.1.4.2.

#### **2.1.4.4 Actions required at an intermediate international exchange**

Upon receipt of an address complete or connect message, the awaiting address complete timer (T7) is stopped.

See also 2.1.4.2.

#### **2.1.4.5 Actions required at an incoming international exchange**

Upon receipt of an address complete or connect message, the awaiting address complete timer (T7) is stopped.

See also 2.1.4.2.

#### **2.1.4.6 Actions required at the originating exchange**

- a) On receipt of an address complete message with the called line status indicator set to “subscriber free”, an alerting indication is passed to the calling party if possible.
- b) On receipt of the address complete message, the awaiting address complete timer (T7) is stopped and the awaiting answer timer (T9) is started. If timer (T9) expires, the connection is released and an indication is sent to the calling subscriber.
- c) If the connect message is received, then the awaiting address complete timer (T7) is stopped (see 2.1.7.6).

#### **2.1.4.7 Through-connection and awaiting answer indication at the destination exchange**

The sending of the awaiting answer indication (e.g. ring tone) at the destination exchange depends on the type of call. On speech and 3.1 kHz calls and call to an analogue called party, the awaiting answer indication is applied to the transmission path to the calling party from the destination exchange on receipt of an alerting indication from the called party or from information contained within the destination exchange that the called party will not or is prohibited from providing in-band tone.

Regardless of whether tones are to be provided or not, the destination exchange will through-connect after the reception of the connection indication from the called party and before sending the answer/connect message to the preceding exchange.

If the destination exchange does not send the awaiting answer indication because the destination user provides for the sending of tones, then the destination exchange will through-connect the transmission path in the backward direction on receipt of the progress indication.

The complete through-connection of the transmission path at answer is covered in 2.1.7.

#### **2.1.4.8 Address complete message with other information**

Additional information can be included in the address complete messages (e.g. echo control information).

#### **2.1.4.9 Return of address complete message in interworking situations**

An address complete message will not be sent until the cross-office check is made, if applicable (see Recommendation Q.543). If the succeeding network does not provide electrical called-party's-line-condition indications, the last Signalling System No. 7 exchange shall originate and send an address complete message when the end of address signalling has been determined:

- a) by receipt of an end-of-pulsing (ST) signal; or
- b) by receipt of the maximum number of digits used in the national numbering plan; or
- c) by analysis of the national (significant) number to indicate that a sufficient number of digits has been received to route the call to the called party; or
- d) by receipt of an end-of-selection signal from the succeeding network (e.g. number received signal in Signalling System No. 5); or
- e) exceptionally, if the succeeding network uses overlap signalling and number analysis is not possible, by observing that timer (T10) has elapsed since the last digit was received, and that no fresh information has been received; in such circumstances, transmission to the national network of the last digit received must be prevented until the end of the waiting period which causes an address complete message to be sent backward. In this way, it is ensured that no national answer signal can arrive before an address complete message has been sent.

If in normal operation, a delay in the receipt of an address complete signal from the succeeding network is expected, the last common channel signalling exchange will originate and send an address complete message 15 to 20 seconds [timer (T11)] after receiving the latest address message. The time-out condition is an upper limit considering the clauses of 2.9.8.3 [20 to 30 seconds waiting for address complete message timer (T7) for outgoing international exchanges in abnormal release conditions].

#### **2.1.4.10 Access delivery indication**

In case the destination exchange delivered any call set-up information at the ISDN access, this will be indicated in the access delivery indicator in the first backward message (address complete, connect or release).

Only the destination exchange can generate the access delivery indicator.

An intermediate exchange (e.g. an outgoing international exchange) is required to recognize the access delivery indicator when it is received, and pass it on if possible.

When an intermediate exchange does not receive the access delivery indicator, no action is required. This would be the case when the destination exchange or the network between the destination exchange and the intermediate exchange does not support the access delivery indicator.

#### **2.1.5 Call progress (basic call)**

The call progress message is sent (only after the address complete message) from an exchange in the backward direction indicating that an event has occurred during call set-up which should be relayed to the calling party.

If the call progress message would exceed the 272 octet limit for Message Transfer Part transfer, it shall be segmented by use of the segmentation message; see 2.1.12.

##### **2.1.5.1 Actions required at the destination exchange**

The call progress message is sent from the destination exchange if the address complete message has been sent and subsequently:

- an indication is received that the called party is being alerted, the call progress message contains an event indicator that is set to “alerting”;
- a progress indication is received from the called party, the call progress message contains an event indicator that is set to “progress”.

If the indication received from the called party contains a “progress indication”, this is carried by the call progress message in the access transport parameter (transported unchanged across the public network).

The destination exchange may on receipt of the indication from the called party, that contains an appropriate progress indicator, through-connect the speech path, see 2.1.4.7.

In the case of call failure and the connection of a tone or announcement being returned before the address complete message has been returned, see 2.2.4.

##### **2.1.5.2 Actions required at an intermediate national, outgoing international, intermediate international and incoming international exchange**

On receipt of a call progress message, an intermediate exchange will send the corresponding call progress message to the preceding exchange.

##### **2.1.5.3 Actions required at the originating exchange**

On receipt of a call progress message at the originating exchange, no state change occurs, and the appropriate indication is sent to the calling user. If the call progress message contains information carried in the access transport parameter, it is transferred unaltered into the indication returned to the calling user.

#### **2.1.6 Information messages**

##### **2.1.6.1 Requesting information (national use)**

An information request message may be sent to any exchange in the forward (backward) call establishment direction after sending (receiving) an initial address message until when routing is complete, i.e. when the address complete message or connect message is generated at the destination exchange or when it is received by the intermediate or originating exchange.

### **2.1.6.2 Sending solicited information (national use)**

On sending an information request message a timer (T33) is started. No second information request message may be sent in the same direction until a response information message is received. If the timer (T33) expires before the response message is received, see 2.9.7. The value of this timer (T33) is 12-15 seconds to allow for a cascade of information request messages, as described in item ii). The response information message may be sent as follows:

- i) if all the information requested is available locally, then an information message containing all the required information is sent in response;
- ii) if all the information is not available locally, but may be available remotely, then an information request message may be sent to a subsequent exchange in the connection in an attempt to extract the information not locally available. (This information request message may be delayed if one has already been sent and the response not yet received.) On receipt of a response, all the information necessary to respond to the original information message is sent in an information message;
- iii) if all the information is not available locally or remotely, then an information message containing only the available information is sent and the requested but not delivered information is indicated as “not available”, using either the indication in the information indicator or an appropriate coding in the requested parameter.

### **2.1.6.3 Receiving a solicited information message (national use)**

Upon receipt of an information message timer T33 is stopped.

If this message neither contains the requested information nor an indication that the requested information is not available, the actions taken will depend on whether the call can be progressed. Any information which was not requested is discarded.

### **2.1.7 Answer message**

If the answer message would exceed the 272 octet limit for Message Transfer Part transfer, it shall be segmented by use of the segmentation message; see 2.1.12.

#### **2.1.7.1 Actions required at the destination exchange**

When the called party answers, the destination exchange connects through the transmission path and the ringing tone is removed if applicable. An answer message to the preceding exchange is sent. If the destination exchange is the exchange controlling charging, then charging may begin.

#### **2.1.7.2 Actions required at an intermediate national exchange**

Upon receipt of an answer message, an intermediate national exchange sends the corresponding answer message to the preceding exchange and, if this is the exchange controlling charging, charging may begin, and timer (T9) is stopped.

#### **2.1.7.3 Actions required at an outgoing international exchange**

Upon receipt of an answer message, an outgoing international exchange sends the corresponding answer message to the preceding exchange and timer (T9) is stopped.

#### **2.1.7.4 Actions required at an intermediate international exchange**

Upon receipt of an answer message, an intermediate international exchange send the corresponding answer message to the preceding exchange.

#### **2.1.7.5 Actions required at an incoming international exchange**

See 2.1.7.4.

#### **2.1.7.6 Actions required at the originating exchange**

When the originating exchange receives an answer message indicating the required connection has been completed, the transmission path is connected-through in the forward direction, if not already connected. The awaiting answer timer (T9) is stopped. If the originating exchange is the exchange controlling charging, charging may begin if applicable. The calling party is informed.

### **2.1.7.7 Return of answer from automatic terminals**

When connections are set-up to terminals having an automatic answer feature, the alerting indication may not be received from the called party. If a destination exchange receives an answer indication, an answer message is sent provided that an address complete message has been sent, otherwise the connect message is sent.

### **2.1.8 Continuity-check**

Because the signalling in Signalling System No. 7 does not pass over the circuit, facilities should be provided for making a continuity-check of the circuit in the circumstances described below.

The application of the continuity-check depends on the type of the transmission system used for the circuit. For transmission systems having some inherent fault indication features giving an indication to the switching system in case of fault, a continuity-check is not required. However, a per call continuity-check may be needed on fully digital circuits when circuits or bundles of circuits in primary multiplex groups are dropped and inserted en route between switches, and alarm indications carried on bits of the primary multiplex frame structure are lost in passing through an intermediate transmission facility that does not relay them transparently. Typical, per call continuity-checks may be needed when the transmission link between switches contains a TDMA satellite system, a digital circuit multiplication system or a digital access and cross connection system, where fault indications are lost (see Recommendation Q.33).

When an initial address message is received with a request for a continuity-check, a continuity-check loop is connected.

Means should be provided in Signalling System No. 7 to detect circuit identification code misunderstandings between Signalling System No. 7 exchanges.

For exchanges having both analogue and digital circuits served by Signalling System No. 7, the continuity-check initiated by a continuity-check request message could be used to test for proper alignment of circuit code identities. On those exchanges, reception of a continuity-check request message should always cause a loop to be attached to the circuit.

Alternative methods for detection of circuit identity misunderstandings in exchanges with all digital circuits may be employed.

The continuity-check is not intended to eliminate the need for routine testing of the transmission path.

The continuity check of the circuit will be done, link-by-link, on a per call basis or by a statistical method prior to the commencement of conversation. Procedures and requirements are specified in 7/Q.724.

The actions to be taken when pilot supervision is used are described in 9/Q.724.

When an initial address message is received with a request for continuity check (either on this circuit or on a previous circuit), timer T8 is started. On receipt of a successful indication of continuity check in a continuity message, timer T8 is stopped. However, if timer T8 expires, the connection is cleared (cause 41).

If an indication of continuity check failure is received in a continuity message, timer T27 is started awaiting a continuity re-check request. Also, the connection to the succeeding exchange is cleared. Timer T27 is stopped when the continuity-check request message is received and timer T36 is started awaiting a continuity or release message.

If either timer T27 or timer T36 expires, a reset circuit message is sent to the preceding exchange. On reception of the release complete message, the circuit is set to idle.

Where circumstances require per call continuity checking for multi-rate connection type calls, the continuity of the single 64 kbit/s circuit whose circuit identification code is contained in the initial address message shall be checked.

### **2.1.9 Charging**

Charging indicators are basically defined for national use. Therefore, unless there is bilateral agreement, the decision to charge a call or not, or to start international accounting will not be decided upon reception of these indicators.

### 2.1.10 Forward transfer message

The forward transfer message may be sent in telephony semi-automatic working in either of the following two cases:

- a) following a call switched automatically to a subscriber, or following a call established via a special operator, the controlling operator wishes to call in an assistance operator. On receipt of the forward transfer message at the incoming international exchange, an assistance operator is called in;
- b) following a call via Codes 11 and 12, the controlling operator wishes to recall the incoming international exchange. Receipt of the forward transfer message at the incoming international exchange recalls the incoming operator on calls completed via the operator positions at the exchange.

The support of the forward transfer message in the international interface does not impose that the related functions are implemented in each incoming or outgoing international exchange (e.g. language assistance).

### 2.1.11 Transit network selection (national use)

If transit network selection information is included in the set-up information from the calling party or is provided on a subscription basis, this information is carried in the transit network selection parameter, and is used for routing of the call, e.g. to a specific carrier.

A sequence of transit networks may be specified by the calling party, in which case the transit network selection parameter is repeated in the order specified.

### 2.1.12 Simple segmentation

The simple segmentation procedure uses the segmentation message to convey an additional segment of an overlength message. Any message containing either the optional forward or backward call indicators can be segmented using this method. This procedure provides a mechanism for the transfer of certain messages whose contents are longer than 272 octets but not longer than 544 octets.

The procedure is as follows:

- a) The sending exchange, on detecting that the message to be sent exceeds the 272 octet limit of the Message Transfer Part, can reduce the message length by sending some parameters in an segmentation message sent immediately following the message containing the first segment.
- b) The parameters that may be sent in the second segment using the segmentation message, are the user-to-user information, generic digit, generic notification, generic number and access transport parameters. If the user-to-user information and access transport parameters cannot be carried in the original message and the two together do not fit in the segmentation message, the user-to-user information parameter is discarded.
- c) The sending exchange sets the Simple Segmentation Indicator in the optional forward or backward call indicators to indicate that additional information is available.
- d) When a message is received, at a local exchange, with the Simple Segmentation Indicator set to indicate additional information is available, the exchange starts timer T34 to await the segmentation message. This action may also take place at incoming or outgoing international exchanges if policing of information is required.
- e) When the segmentation message is received timer T34 is stopped, and the call continues.
- f) In case any other message except the ones listed below is received before the segmentation message containing the second segment, the exchange should react as if the second segment is lost, i.e. the timer T34 is stopped and the call continues.

The messages are :

- Continuity;
- Blocking;
- Blocking acknowledgement;
- Circuit group blocking;

- Circuit group blocking acknowledgement;
  - Unblocking;
  - Unblocking acknowledgement;
  - Circuit group unblocking;
  - Circuit group unblocking acknowledgement;
  - Circuit group query;
  - Circuit group query response.
- g) After expiry of timer T34, the call shall proceed and a received segmentation message containing the second segment of a segmented message is discarded.
- h) At an incoming or outgoing international exchange, when following the simple segmentation procedure, it is possible that the exchange has to reassemble an incoming message and subsequently re-segment it for onward transmission. In this case it has to be ensured that any unrecognized parameters received in the first, or second, segment are transmitted in the first, or second, segment respectively, when the passing of the parameter is required by the compatibility procedure.

#### **2.1.12.1 Interworking with Q.767 and Blue Book (1988 version) ISDN-User Parts**

For interworking with these ISDN-User Part exchanges no special action is required.

## **2.2 Unsuccessful call set-up**

If at any time in the call set-up the connection cannot be completed, the exchange will (if applicable):

- a) return an indication (in band or out band) to the calling party (see 2.2.4); or
- b) attempt to re-route the call set-up; or
- c) initiate release procedures to the preceding and/or succeeding exchange (see 2.2.1).

### **2.2.1 Actions at exchange initiating a release message**

The initiating exchange immediately starts the release of the switched path (if established). The exchange sends a release message to the preceding and/or succeeding exchange and timers T1 and T5 are started to ensure that a release complete message is received from the preceding and/or succeeding exchange (expiration of timers T1 and T5 is covered in 2.9.6).

### **2.2.2 Actions at intermediate exchange**

On receipt of a release message an intermediate exchange:

- i) immediately start the release of the switched path; when the circuit is reselectable, a release complete message is sent;
- ii) at the same time as the start of the release of the switched path, a release message is sent to the preceding or succeeding exchange. Timers T1 and T5 are started to ensure that a release complete message is received from the preceding or succeeding exchange (expiration of timers T1 and T5 is covered in 2.9.6).

### **2.2.3 Actions at the controlling exchange (i.e. the exchange controlling the call)**

On receipt of a release message from the preceding or succeeding exchange, the controlling exchange starts the release of the switched path. In addition, the controlling exchange will (if applicable):

- a) return an indication (in-band or out-band) to the calling party (see 2.2.4); or
- b) attempt to re-route the call set-up; or
- c) initiate release procedures to the preceding or succeeding exchange (see 2.2.1).

In case a) above an indication is carried in the call progress message or address complete message indicating in-band information is available along with the cause parameter. The cause value should reflect the reason of call failure in the same way as the in-band tone or announcement to be applied by the controlling exchange (see 2.2.4).

When the controlling exchange is ready for circuit re-selection, a release complete message is sent to the preceding or succeeding exchange.

#### **2.2.4 Tones and announcements**

The applicability of tones and announcements is decided based on the transmission medium requirements. Tones and announcements are applicable for the following transmission medium requirements;

- speech;
- 3.1 kHz audio; and
- 64 kbit/s unrestricted preferred.

If a call set-up fails and no in-band tone or announcement has to be returned to the calling party from an exchange succeeding the controlling exchange, this exchange sends a release message to the controlling exchange. The cause value should reflect the reason of the call failure in the same way as the in-band tone or announcement to be applied by the controlling exchange.

If a call set-up fails and an in-band tone or announcement has to be returned to the calling party from an exchange or called party, the exchange or user concerned connects the in-band tone or announcement to the transmission path. If a time-out occurs at the exchange providing the in-band tone or announcement, the exchange sends a release message to the preceding exchange with cause value 31 (normal unspecified).

If an address complete message has been returned to the preceding exchange a call progress message indicating that in-band tone information is available along with the cause parameter, is returned to the preceding exchange (see 2.1.5). The cause value should reflect the reason of call failure in the same way as the in-band tone or announcement to be applied.

If an address complete message has not been returned to the preceding exchange already, an address complete message, with the cause parameter and the “in-band information” indicator set in the optional backward call indicator, will be returned to the originating exchange. The cause value should reflect the reason of call failure in the same way as the in-band tone or announcement to be applied.

In case a special tone or announcement has to be applied due to an event only known by a certain exchange and not covered by a cause value, no cause parameter is included in either the address complete or call progress messages. The answer message must not be sent in this case.

For the preceding exchanges the inclusion of the cause parameter in the address complete or call progress messages implies an unsuccessful call set-up. The cause parameter will not be included for unsuccessful call set-up's when interworking has occurred and the in-band tone or announcement is returned from the exchange beyond the interworking point.

#### **2.2.5 Address incomplete**

The determination that the proper number of digits has not been received can be made at once if the end-of-pulsing signal is received.

When overlap working is used and the end-of-pulsing has not been received, the release message with cause 28 (address incomplete) will be sent 15-20 seconds (T35) after receipt of the latest address message and before receipt of the minimum or fixed number of digits for forward routing of the call.

### **2.3 Normal call release**

The release procedures are based on a two message (release, release complete) approach where by the release message initiates release of the circuit switched connection.

The same procedures are used in the network irrespective of whether they are initiated by the calling party, the called party or the network.

To satisfy the need for rapid transfer of release across the network, it is required that the circuit is selectable from the subsequent exchange within the mean cross-office transfer time,  $T_{cu}$ , for simple messages as specified in Recommendation Q.766.



### 2.3.1 Release initiated by a calling party

#### a) *Actions at the originating exchange*

On receipt of a request to release the call from the calling party, the originating exchange immediately starts the release of the switched path. A release message is sent to the succeeding exchange and timers T1 and T5 are started to ensure that a release complete message is received from the succeeding exchange (expiration of timers T1 and T5 is covered in 2.9.6).

#### b) *Actions at an intermediate exchange*

On receipt of a release message from the preceding exchange, an intermediate exchange:

- i) immediately starts the release of the switched path; when the circuit is reselectable, a release complete message is returned to the preceding exchange;
- ii) at the same time as the start of the release of the switched path, sends a release message to the succeeding exchange. Timers T1 and T5 are started to ensure that a release complete message is received from the succeeding exchange (expiration of timers T1 and T5 is covered in 2.9.6).

#### c) *Actions at the destination exchange*

On receipt of a release message from the preceding exchange, the destination exchange will start the release of the switched path. When the circuit is ready for reselection, a release complete message is returned to the preceding exchange.

#### d) *Charging (national use)*

Charging is stopped upon receipt of the release message at the charging exchange or on receipt of a request to release the call from the calling party when the charging exchange is the originating exchange.

#### e) *Collision of release messages*

In the case when two points in the connection both initiate the release of a call, a release message may be received at an exchange from a succeeding or preceding exchange after the release of the switched path is initiated. In this case, the exchange will return a release complete message to the exchange from which the concerned release message was received. The release complete message will be sent when the switch path has been released.

### 2.3.2 Release initiated by a called party

The procedures in 2.3.1 apply, except that the functions at the originating and destination exchanges are transposed.

### 2.3.3 Release initiated by the network

The procedures in 2.3.1 apply, except that they can be initiated at any exchange (originating, destination or intermediate).

### 2.3.4 Storage and release of initial address message information

Each exchange of the connection shall store during the call set-up the initial address message information sent (the originating exchange) or received (intermediate or destination exchange). The information to be stored includes all parameters in the initial address message and, if the initial address message has been segmented, in the subsequent segmentation message. The contents of the initial address message information shall be updated, if the value of parameters change during the call set-up.

The initial address message information can be released from memory:

- a) in the originating exchange when the address complete message or connect message has been received and the calling party does not subscribe to a supplementary service which would cause a new call set-up. The release of the information when the calling party does subscribe to a supplementary service is covered in Recommendation Q.730;
- b) in the intermediate exchange when the address complete message or the connect message has been received;

- c) in the destination exchange when the address complete message or connect message has been sent and the called party does not subscribe to a supplementary service which would cause a new call set-up. The release of the information when the called party does subscribe to a supplementary service is covered in Recommendation Q.730,

and when the call is released earlier and no automatic repeat attempt is to be attempted.

## **2.4 Suspend, resume**

### **2.4.1 Suspend**

The suspend message indicates a temporary cessation of communication without releasing the call. It can only be accepted during the conversation/data phase.

A suspend message can be generated by the network in response to a clearback indication from an interworking node or an on-hook condition from an analogue called party.

- a) *Action at the destination exchange or an interworking exchange*

On receipt of an on-hook condition in the destination exchange or a clearback signal at the interworking exchange, the exchange may send a suspend (network) message to the preceding exchange.
- b) *Action at the intermediate exchange*

On receipt of a suspend message the exchange will send a suspend message to the preceding exchange.
- c) *Action at the controlling exchange*

On receipt of the on-hook condition or clearback indication or suspend message, the controlling exchange starts a timer (T6) to ensure that an off-hook condition, a re-answer indication, a resume (network) message or a release message is received. The value of this timer (T6) is covered in Recommendation Q.118. If the timer (T6) expires, the procedures in 2.4.3 apply.
- d) *Actions at the incoming international exchange*

On receipt of the on-hook condition or clearback indication or suspend (network) message, the incoming international exchange sends to the preceding exchange a suspend (network) message and starts a timer (T38), to ensure that a release message is received. The value of this timer is covered in Recommendation Q.118. If the timer (T38) expires, the procedure in 2.4.3 applies. The procedure described above may not be applied in the incoming international exchange if a similar arrangement is already made in the network of the incoming country.

### **2.4.2 Resume**

A resume message indicates a request to recommence communication. A request to release the call received from the calling party will override the suspend/resume sequence and the procedures given in 2.3 will be followed.

A resume message is initiated by the network, if a suspend message had previously been sent, in response to a re-answer indication from an interworking node or an off-hook condition from an analogue called party.

- a) *Action at the destination exchange or interworking exchange*

On receipt of a re-answer indication at the interworking exchange or an off-hook condition in the destination exchange, the exchange may send a resume (network) message to the preceding exchange if a suspend (network) message had previously been sent.
- b) *Actions of the intermediate exchange*

On receipt of a resume message the exchange will send a resume message to the preceding exchange.
- c) *Action of the controlling exchange (i.e. exchange controlling the call)*

On receipt of the off-hook condition, re-answer signal, release message or resume message the controlling exchange stops the timer (T6) [started in 2.4.1 c)].

d) *Actions at the incoming international exchange*

On receipt of the off-hook condition, re-answer signal, release message or resume (network) message from the succeeding exchange, the incoming international exchange stops the timer (T38) [started in 2.4.1 d)].

### 2.4.3 Expiration of timer (T6) or timer (T38)

If a request for reconnection or a resume (network) message is not received within timer (T6) or timer (T38) both covered in Recommendation Q.118, then the exchange where the timer has been started will initiate the release procedure on both sides. Cause value 102 is used in the release message.

## 2.5 Signalling procedures for connection type allowing fallback

### NOTES

1 The procedure assumes that Recommendation E.172 will at an appropriate time include routing rules for the transmission medium requirement parameter value “64 kbit/s unrestricted preferred”.

2 The question of additional network signalling procedures to support the provision of tones and announcements in the case of 64 kbit/s unrestricted calls without the application of fallback is for further study.

### 2.5.1 Actions in the forward direction

#### 2.5.1.1 Actions at the originating exchange

Two bearer capability information elements are received in the call request from the access. These bearer capability information elements are mapped into one corresponding user service information parameter and one corresponding user service information prime parameter to be carried in the initial address message.

The user service information prime parameter carries the preferred bearer capability and the user service information parameter carries the fallback bearer capability.

The transmission medium requirement parameter is coded “64 kbit/s unrestricted preferred”, and the call is routed on a circuit according to this transmission medium requirement parameter.

This means that the connection must be capable of satisfying the connection type requirements of both 64 kbit/s unrestricted and 3.1 kHz audio or speech connection types, e.g. it must be possible to invoke echo control on the connection and/or A-law/ $\mu$ -law conversion if applicable, and the signalling procedures for fallback.

The transmission medium requirement prime parameter carries the fallback connection type and is coded either as 3.1 kHz audio or speech, depending on which connection type should be used in the case of fallback.

See Figures D.1 to D.6.

#### 2.5.1.2 Actions at an intermediate exchange

Actions in this subclause may apply both for incoming or outgoing international exchanges, and national or international intermediate exchanges.

##### 2.5.1.2.1 Succeeding network does have the capability of performing fallback

The intermediate exchange will set up the call on a circuit according to the transmission medium requirement parameter 64 kbit/s unrestricted preferred whenever available.

See Figures D.1 to D.4.

If congestion on the route is encountered, and if there is no alternative route available supporting the connection type allowing fallback, fallback procedures will be initiated according to 2.5.1.2.2.

##### 2.5.1.2.2 Succeeding network does not have the capability of performing fallback

In case of either:

- interworking to an ISDN-User Part not supporting the transmission medium requirement parameter “64 kbit/s unrestricted preferred”; or
- there is no circuit available being capable of satisfying the connection type requirements of “64 kbit/s unrestricted preferred”,

the intermediate exchange will continue the call, discard the user service information prime parameter, maintain the user service information parameter, change the transmission medium required parameter in accordance with the fallback connection type contained in the transmission medium requirement prime parameter and then discard the transmission medium requirement prime parameter. This will typically be the case when the succeeding network consists of an ISDN-User Part conforming to Q.767 or a version of this Recommendation not supporting the procedures.

NOTE – This will also be the case during an interim period of time when interworking to ISDN-User Part networks not capable of outband control of echo control devices and/or  $\mu$ -law/A-law converters.

See Figure D.6.

In case of:

- interworking to PSTN,

the intermediate exchange will continue the call into the PSTN with the fallback connection type.

See Figure D.5.

If echo control is required on the connection, appropriate procedures will be initiated (see 2.7).

### **2.5.1.3 Actions at the destination exchange**

If the destination access is ISDN, then the information carried in the user service information parameter and the user service information prime parameter are sent to the called user in accordance with the user network interface protocol.

See Figures D.1 to D.3.

If the called user is an analogue subscriber, the destination exchange will continue the call into the PSTN.

See Figure D.4.

## **2.5.2 Actions in the backward direction – Fallback indicated before answer**

### **2.5.2.1 Actions at the destination exchange**

Fallback before answer may be indicated by the access. The destination exchange will also know that fallback has occurred when the called user is an analogue subscriber.

If the destination exchange knows that fallback has occurred, this will be indicated in the backward direction by including a transmission medium used parameter (which has been set according to the fallback connection type indicated by the transmission medium requirement prime parameter) in the address complete message or call progress message.

The transmission medium used parameter is indicating the fallback connection type.

Appropriate actions to modify network resources will be initiated.

If echo control is required on the connection, appropriate procedures will be initiated (see 2.7).

See Figures D.3 and D.4.

### **2.5.2.2 Actions at the intermediate exchange**

Actions in this subclause may apply both for incoming or outgoing international exchanges, and national or international intermediate exchanges.

#### **2.5.2.2.1 Succeeding network does have the capability of performing fallback**

The intermediate exchange will know that fallback has occurred by receiving the transmission medium used parameter. This parameter indicates the fallback connection type.

Appropriate actions to modify network resources, e.g.  $\mu$ -law/A-law conversion, will be initiated if applicable.

If echo control is required on the connection, appropriate procedures will be initiated (see 2.7).

See Figures D.2, D.3, D.4 and D.6.

#### **2.5.2.2.2 Succeeding network does not have the capability of performing fallback**

The intermediate exchange will include a transmission medium used parameter (which has been set according to the fallback connection type indicated in the transmission medium requirement prime parameter) in the address complete message or call progress message indicating that fallback has occurred for this call.

Appropriate actions to modify network resources, e.g.  $\mu$ -law/A-law conversion, will be initiated.

If echo control is required on the connection, appropriate procedures will be initiated (see 2.7).

See Figures D.5 and D.6.

#### **2.5.2.3 Actions at the originating exchange**

The originating exchange will know that fallback has occurred by receiving the transmission medium used parameter. The transmission medium used parameter indicates the fallback connection type.

Appropriate actions to modify network resources will be initiated.

If echo control is required on the connection, appropriate procedures will be initiated (see 2.7).

See Figures D.2, D.3, D.4, D.5 and D.6.

### **2.5.3 Actions in the backward direction – Fallback indicated at answer**

#### **2.5.3.1 Actions at the destination exchange**

When the destination exchange knows at answer that fallback has occurred, this will be indicated by including a transmission medium used parameter (which has been set according to the fallback connection type indicated in the transmission medium requirement prime parameter) in the answer or connect message.

This will typically be the case when the called user is ISDN, and has indicated fallback bearer capability information, or no bearer capability information at all when answering the call.

Appropriate actions to modify network resources will be initiated.

If echo control is required on the connection, appropriate procedures will be initiated (see 2.7).

See Figure D.2.

#### **2.5.3.2 Actions at the intermediate exchange**

Actions in this subclause may apply both for incoming or outgoing international exchanges, and national or international intermediate exchanges.

The intermediate exchange will know that fallback has occurred by receiving the transmission medium used parameter. This parameter indicates the fallback connection type.

Appropriate actions to modify network resources, e.g.  $\mu$ -law/A-law conversion, will be initiated.

If echo control is required on the connection, appropriate procedures will be initiated (see 2.7).

See Figure D.2.

#### **2.5.3.3 Actions at the originating exchange**

The originating exchange will know that fallback has occurred by receiving the transmission medium used parameter. The transmission medium used parameter indicates the fallback connection type.

Appropriate actions to modify network resources will be initiated.

If echo control is required on the connection, appropriate procedures will be initiated (see 2.7).

See Figure D.2.

### **2.5.4 Actions in the backward direction – Fallback does not occur**

The non-occurrence of fallback is indicated in the backward direction by the absence of the transmission medium used parameter.

No further actions are required in any of the exchanges involved in the call.

See Figure D.1.

## **2.6 Propagation delay determination procedure**

The procedure provides means to determine the total propagation delay for a connection.

The propagation delay information is accumulated during call set-up in the forward direction. The result is sent in the backward direction as call history information before the active phase of a call.

### **2.6.1 Procedure**

The procedure starts from the principle that the propagation delay of a connection is detected during call set-up by increasing the propagation delay counter contained in the initial address message and that the accumulated result is sent in backward direction included in the answer or connect message.

#### **2.6.1.1 Actions at the initiating exchange**

The initiating exchange is the exchange which initiates the procedure, e.g. a typical case is the originating local exchange.

##### **2.6.1.1.1 Actions referring to the propagation delay counter**

The initiating exchange shall always include the propagation delay counter into the initial address message. Initially, the counter is set to 0 ms or if an access delay value is available, it is set to that delay value.

Depending on the chosen route to the succeeding exchange, the originating exchange increases the counter by the value representing the appropriate delay value prior to sending the initial address message.

The value of the delay for each circuit has to be available in the exchange.

If the chosen circuit includes a satellite link, also the satellite indicator must be set accordingly.

##### **2.6.1.1.2 Actions referring to the call history information**

Upon receipt of the call history information parameter in the answer or connect message, the initiating exchange has to store the received delay value until the call is released.

#### **2.6.1.2 Actions at an intermediate exchange**

An intermediate exchange can be a national transit exchange, an incoming or outgoing gateway exchange or an international transit exchange.

##### **2.6.1.2.1 Actions referring to the propagation delay counter**

Upon receipt of the initial address message, the intermediate exchange analyzes the routing information in order to select a suitable circuit to the succeeding exchange.

After choosing a circuit, the propagation delay counter shall be increased by the value of the corresponding delay value.

The value of the delay for each circuit has to be available in the exchange.

The initial address message is sent to the succeeding exchange containing the new value of the propagation delay counter.

##### **2.6.1.2.2 Actions referring to the call history information**

The intermediate exchange shall pass on the received answer or connect message including the call history information parameter.

#### **2.6.1.3 Actions at the terminating exchange**

The terminating exchange is the exchange which terminates the procedure, e.g. a typical case is the local destination exchange.

##### **2.6.1.3.1 Actions referring to the propagation delay counter**

Upon receipt of the initial address message including the propagation delay counter, the destination exchange shall increase the value by the delay value of the terminating access if available and store the delay value until the call is released.

### **2.6.1.3.2 Actions referring to the call history information**

Prior to sending the answer or connect message to the preceding exchange, the call history information parameter shall be included in the message.

The value of the call history information parameter is set according to the stored value of the propagation delay counter.

### **2.6.1.4 Interactions with other signalling systems**

There are two basic interworking situations namely:

- i) signalling systems supporting the procedure toward signalling systems not supporting the procedure;
- ii) signalling systems not supporting the procedure toward signalling systems supporting the procedure.

#### **2.6.1.4.1 Interworking from signalling systems supporting the procedure to signalling systems not supporting the procedure**

In case of an interworking situation, the interworking exchange shall store the propagation delay value accumulated up to this point until the call is released. If a delay value referring to the part of the connection where the procedure is not supported is available, this delay value shall be added to the stored one.

The interworking exchange acts like a terminating exchange according to 2.6.1.3.

Upon receipt of the answer or connect message, the interworking exchange shall include the call history information parameter set to the stored delay value.

The answer or connect message including the call history information parameter is sent to the preceding exchange by the interworking exchange.

#### **2.6.1.4.2 Interworking from signalling systems not supporting the procedure to signalling systems supporting the procedure**

Because of the signalling systems which do not support the procedure do not include the propagation delay counter, the interworking exchange shall insert the propagation delay counter in the initial address message resetting it to 0 ms. If a delay value referring to the part of the connection where the procedure is not supported is available, the propagation delay counter shall be set to this delay value.

The interworking exchange acts like an initiating exchange according to 2.6.1.1.

The calculated delay value in the interworking exchange shall reflect the delay incurred on the preceding circuit(s). This includes delay values corresponding to satellite delays, if applicable.

Prior to sending the initial address message to the succeeding exchange, the propagation delay counter shall be increased according to the value of the outgoing circuit chosen.

### **2.6.1.5 Abnormal procedures**

At any exchange where the incoming signalling system supports the propagation delay determination procedure, the propagation delay counter parameter may be missing from the received initial address message. In this case, a propagation delay value should be created as in the interworking case described in 2.6.1.4.2. The procedure should then continue as in 2.6.1.2, 2.6.1.3 or 2.6.1.4 as appropriate.

At any exchange where the outgoing signalling system supports the propagation delay determination procedure, the call history information parameter may be missing from the answer or connect message received. In this case, no special action is required; the answer or connect message is sent backwards without this parameter.

At any exchange that supports the propagation delay procedure, a confusion message may be received referring to the propagation delay counter or the call history information parameter. The confusion message should be discarded. Any stored propagation delay value is also discarded.

## **2.7 Echo control procedure**

### **2.7.1 General**

The echo control procedure is used on a per call basis to convey information between exchange nodes about the demand and ability to insert half echo control devices.

The procedure is invoked when a call is to be routed on a connection for which echo control is necessary or when the accumulated delay the call has encountered exceeds the allowed value (see Recommendation G.131). It could be initiated at the originating exchange, at an intermediate exchange or at the destination exchange.

It is recognized in these procedures that not all exchanges will support the dynamic echo control procedures. It is therefore recognized that there will be a coexistence of exchanges supporting echo control signalling procedures of *Blue book* with the signalling procedures described in this Recommendation. This coexistence should result in proper echo control procedures as defined in Recommendation Q.115 and should not result in a requirement for new signalling capabilities in exchanges not supporting dynamic echo control procedures described in this Recommendation.

After the address complete has been sent, there may be a need to invoke echo control procedures. Echo control procedure can be used to activate or deactivate echo control devices.

The procedures given below make use of the propagation delay determination procedure. The complete set of criteria for including echo control devices in a connection is given in Recommendation Q. 115.

If there is no explicit indication for the setting of the indicators of the echo control information parameter field, the coding 00 (no information) is assumed.

### **2.7.2 Before address complete**

#### **2.7.2.1 Forward direction**

##### **2.7.2.1.1 Action at the originating exchange**

If an originating exchange has sufficient information to determine that echo control is necessary for the outgoing circuit, then:

- An outgoing half echo control device is enabled.
- The echo control device indicator in the nature of connection indicators parameter of the initial address message is set to “outgoing half echo control device included”.
- The exchange notes in memory that there may be a need to include/enable an incoming half echo control device in the circuit for this call provided the exchange does not know that the succeeding exchange will include an incoming half echo control device.

##### **2.7.2.1.2 Action at an intermediate exchange**

The echo control procedure invoked at an intermediate exchange is based on the calculated delay value for the connection at the exchange. The calculated delay value is the sum of the delay obtained from the incoming initial address message and the delay value of the outgoing circuit.

- a) When the nature of connection indicators parameter in the initial address message indicates that an half echo control device is already included, the actions are independent of the calculated delay value. The following actions occur:
  - i) The exchange has echo control devices available
    - No change is made to the nature of connection indicators parameter in the initial address message.
    - The exchange notes in memory that there may be a need to include/enable an incoming half echo control device in the circuit for this call provided the exchange does not know that the succeeding exchange will include an incoming half echo control device.
    - Any outgoing half echo control device is disabled.
  - ii) The exchange does not have any echo control devices available
    - No special action is taken.



- b) When the nature of connection indicators parameter in the initial address message does not indicate that an half echo control device is already included or the exchange has not sufficient information to determine that echo control is required for the outgoing circuit, the action depends on the delay value, if available. In case the calculated delay value is not available, no special action is taken. If the calculated delay value is available and higher than the allowed value or the exchange has sufficient information to determine that echo control is necessary, the following actions occur:
- i) The exchange has echo control devices available
    - The exchange notes in memory that there may be a need to include/enable an outgoing half echo control device in the circuit for this call.
    - The exchange notes in memory that there may be a need to include/enable an incoming half echo control device in the circuit for this call provided the exchange does not know that the succeeding exchange will include an incoming half echo control device.
    - The echo control device indicator in the nature of connection indicators parameter of the initial address message is set to “outgoing half echo control device included”.
  - ii) The exchange does not have echo control devices available
    - No special action is taken.

If the calculated delay value is lower than the allowed one, no special action is taken.

### **2.7.2.1.3 Action at the destination exchange**

See 2.7.2.2.1.

## **2.7.2.2 Backward direction**

### **2.7.2.2.1 Action at the destination exchange**

Upon the receipt of an initial address message, the outgoing echo control device indicator in the nature of connection indicators parameter in the initial address message and the delay value of the connection, if available, is evaluated.

- a) When the nature of connection indicators parameter in the initial address message indicates that an outgoing half echo control device is included, the actions are independent of the calculated delay value. The following actions occur:
- i) The exchange has echo control devices available
    - An incoming half echo control device is enabled.
    - The request for outgoing half echo control device is included in the echo control information parameter in the first backward message (i.e. address complete or connect message).
    - The echo control information parameter in the first backward message is set to “outgoing half echo control device not included”.
    - The echo control device indicator of the backward call indicators parameter in the first backward message (i.e. address complete or connect message) is set to “incoming half echo control device included”.
    - Any outgoing half echo control device is disabled.
  - ii) The exchange does not have any echo control devices available
    - The request for an incoming half echo control device is included in the echo control information parameter in the first backward message (i.e. address complete or connect message).
    - The request for an outgoing half echo control device is included in the echo control information parameter in the first backward message (i.e. address complete or connect message).
    - The echo control information parameter in the first backward message is set to “outgoing half echo control device not included”.
    - The echo control device indicator of the backward call indicators parameter in the first backward message (i.e. address complete or connect message) is set to “incoming half echo control device not included”.

- b) When the nature of connection indicators parameter in the initial address message indicates that an half echo control device is not included, the actions depend on the calculated delay value, if available. If the calculated delay value is lower than the allowed one or not available, no special action is taken.

The following actions occur if the calculated delay value is higher than the allowed one and there are echo control devices available:

- i) If an incoming half echo control device is available
- An incoming half echo control device is enabled.
  - The echo control device indicator of the backward call indicators in the first backward message (i.e. address complete or connect message) is set to “incoming half echo control device included”.
- ii) If an incoming half echo control device is not available
- The request for an incoming half echo control device is included in the echo control information parameter in the first backward message (i.e. address complete or connect message).
  - The echo control device indicator of the backward call indicators in the first backward message (i.e. address complete or connect message) is set to “incoming half echo control device not included”.
- iii) If an outgoing half echo control device is available
- The exchange notes in memory that there may be a need to include/enable an outgoing half echo control device.
  - Timer T37 is started.
  - The request for outgoing half echo control device is included in the echo control information parameter in the first backward message (i.e. address complete or connect message).
  - The echo control information parameter in the first backward message (i.e. address complete or connect message) is set to “outgoing half echo control device included”.
- iv) If an outgoing half echo control device is not available
- The request for outgoing half echo control devices is included in the echo control information parameter in the first backward message (i.e. address complete or connect message).
  - The echo control information parameter in the first backward message is set to “outgoing half echo control device not included”.
- c) i) If the destination exchange receives from the preceding exchange the echo control information parameter in a network resource management message indicating that an outgoing half echo control device has been included, the actions at the destination exchange depend on if the exchange has a note in memory that there may be a need to include/enable an outgoing half echo control device in the circuit for the call or not.

If the exchange has a note in memory that there may be a need to include/enable an outgoing half echo control device in the circuit for the call, it will release the outgoing half echo control device and timer T37 is stopped.

If the exchange has no note in memory that there may be a need to include/enable an outgoing half echo control device in the circuit for the call, no special action occurs.

- ii) If the exchange receives a forward network resource management message with the echo control information parameter set to indicate that an outgoing half echo control device is not included, the actions depend on whether the exchange has a note in memory that there may be a need to include/enable an outgoing half echo control device in the circuit for the call.

If the exchange has a note in memory that there may be a need to include/enable an outgoing half echo control device in the circuit for the call, the device is included/enabled and timer T37 is stopped.

If the exchange has no note in memory that there may be a need to include/enable an outgoing half echo control device in the circuit for the call, no special action is taken.

iii) If timer T37 expires, the outgoing half echo control device is included.

#### **2.7.2.2.2 Action at an intermediate exchange**

##### **2.7.2.2.2.1 Interworking of different ISDN User Part messages containing echo control information**

The actions occurring in an intermediate exchange depend on which messages are received and which information is included in the messages. When interworking the different messages, the following principles apply:

- The incoming half echo control device included indication in the backward call indicators parameter in the address complete or connect message is mapped to the corresponding messages sent in the backward direction. If an address complete message has been sent earlier a network resource management message including the indication will be sent.
- The request for an outgoing half echo control device included in the echo control information parameter in the address complete or connect message is mapped to the corresponding message sent in the backward direction. The request for an incoming half echo control device included in the echo control information parameter in the address complete or connect message is mapped to the corresponding message sent in the backward direction if the exchange has no incoming half echo control device available. If an address complete message has been sent earlier this mapping will occur in a network resource management message.
- If a network resource management message is received on the outgoing circuit it is sent backward as a network resource management message.
- If there is no outgoing half echo control device included/enabled and the exchange has no knowledge that there may be a need to include/enable an outgoing half echo control device in the circuit for this call, and a network resource management message is received on the incoming circuit, it is sent forward as a network resource management message.

NOTE – An exchange that has performed a call forwarding is considered as an intermediate exchange.

##### **2.7.2.2.2.2 Actions on the different values of the echo control indicators**

When receiving the different values of the indicators, one of the following actions occurs:

- a) If the echo control device indicator in the address complete, connect message is not set, the actions depend on whether the exchange has a note in memory that there may be a need to include/enable an incoming half echo control device in the circuit for the call or not.

If the exchange has a note in memory that there may be a need to include/enable an incoming half echo control device in the circuit for the call, the following actions are taken:

- The incoming half echo control device is included/enabled.
- The echo control device indicator in the address complete or connect message, is set to “incoming echo control device included”.

If there is no available incoming half echo control device, no special action is taken.

- b) If the echo control device indicator in the address complete, connect is set, or the echo control information parameter in the network resource management message indicates that an incoming half echo control device is included, the actions depend on whether there is an incoming half echo control device included/enabled or not. If the exchange has included/enabled an incoming half echo control device in the circuit for the call, the following actions are taken:

- It shall release the incoming half echo control device.
- No change is made to echo control device indicator in the backward call indicators parameter in the address complete or connect message.
- No change is made to echo control information parameter in the network resource management message.

If there is no incoming half echo control device included/enabled in the exchange, no special action is taken.

c) If the exchange does not receive an echo control information parameter in the address complete or connect message, the following actions occur:

i) If the exchange has echo control devices available

If the exchange knows that a preceding exchange has included/enabled an outgoing half echo control device or that a preceding exchange has a note in memory that there may be a need to include/enable an outgoing half echo control device, the echo control information parameter is set to:

- “outgoing half echo control device requested”;
- “outgoing half echo control device not included”;

and the backward call indicators parameter is set to:

- “incoming half echo control device included”, either because the indication was received in the address complete or connect message, or because the exchange has included one.

If the exchange has a note in memory that there may be a need to include/enable an incoming and outgoing half echo control device, the echo control information parameter is set to:

- “outgoing half echo control device requested”;
- “outgoing half echo control device included”;

and the backward call indicators parameter is set to:

- “incoming half echo control device included”, either because the indication was received in the address complete or connect message, or because the exchange has included one.

If no action was taken when the initial address message was received, no special action is taken.

ii) If the exchange has no echo control device available

If the exchange knows that a preceding exchange has included/enabled an outgoing half echo control device or that a preceding exchange has a note in memory that there may be a need to include/enable an outgoing half echo control device, the echo control information parameter is set to:

- “outgoing half echo control device requested”;
- “outgoing half echo control device not included”;
- “incoming half echo control device requested”, if the echo control device indicator received in the address complete or connect message is set to “incoming half echo control device not included”,

the echo control device indicator is passed as received.

If the exchange does not know that a preceding exchange has included/enabled an outgoing half echo control device or that a preceding exchange has a note in memory that there may be a need to include/enable an outgoing half echo control device, the exchange has to evaluate the propagation delay value.

- If the calculated delay value is available and higher than the allowed one, the echo control information parameter is set to:
  - “outgoing half echo control device requested”;
  - “outgoing half echo control device not included”;
  - “incoming half echo control device requested”, if the echo control device indicator received in the address complete or connect message is set to “incoming half echo control device not included”,

the echo control device indicator is passed as received.

- If the calculated delay value is lower than the allowed one or not available, no special action is taken.

- d) If the echo control information parameter in the address complete, connect, or network resource management message is indicating that an incoming half echo control device is requested, the following actions occur:
- i) If the exchange has half echo control device available
    - An incoming half echo control device is included.
    - The echo control device indicators in the backward call indicators parameter in the address complete or connect message is set to “incoming half echo control device included”.
    - The echo control information parameter in the address complete, connect or network resource management message is set to “incoming half echo control device included”.
    - The echo control information parameter in the address complete, connect or network resource management message is set to “incoming half echo control device not requested”.
  - ii) If the exchange has no echo control device available, no special action is taken.
- e) If the exchange receives the echo control information parameter of the network resource management, address complete or connect message with a request for an outgoing half echo control device, the action depends on whether an outgoing half echo control device is available or not, and if the exchange knows that a preceding exchange has included/enabled an outgoing half echo control device or that a preceding exchange has a note in memory that there may a need to include/enable an outgoing half echo control device in the circuit for the call.

If there are outgoing half echo control devices available and the exchange does not know that a preceding exchange has included/enabled an outgoing half echo control device or that a preceding exchange has a note in memory that there may a need to include/enable an outgoing half echo control device in the circuit for the call. The following actions are taken:

- If the exchange has not enabled an outgoing half echo control device the exchange notes in memory that there may be a need to include/enable an outgoing half echo control device in the circuit for the call. Timer T37 is started.
- If the echo control information parameter indicates that an outgoing half echo control device has been included at a succeeding exchange, a network resource management message is sent in the forward direction indicating in the echo control information parameter, “outgoing half echo control device included”.
- The exchange indicates in the echo control information parameter in the network resource management, address complete or connect message a request for an outgoing half echo control device, and the indication, “outgoing half echo control device included”.

If there is no available half echo control device, no special action is taken.

If the exchange knows that a preceding exchange has included/enabled an outgoing half echo control device or that a preceding exchange has a note in memory that there may be a need to include/enable an outgoing half echo control device in the circuit for the call, no special action is taken.

- f) If the exchange receives a network resource management message from the preceding exchange indicating in the echo control information parameter that an outgoing half echo control device is included, the following actions are taken:
- If the exchange has included/enabled an outgoing half echo control device or has a note in memory that there may be a need to include/enable an outgoing half echo control device in the circuit for the call, it releases or disables the outgoing half echo control device and timer T37 is stopped.
  - If the exchange has not included/enabled an outgoing half echo control device or has not a note in memory that there may be a need to include/enable an outgoing half echo control device in the circuit for the call, no special action is taken.
- g) The outgoing echo control device is included if timer T37 expires.
- h) If the exchange receives a forward network resource management message with the echo control information parameter set to indicate that an outgoing half echo control device is not included, the actions depend on whether the exchange has a note in memory that there may be a need to include/enable an outgoing half echo control device in the circuit for the call.

If this exchange has a note in memory that there may be a need to include/enable an outgoing half echo control device in the circuit for the call, the device is included/enabled and timer T37 is stopped. The network resource management message is not sent to the succeeding exchange.

If this exchange has not a note in memory that there may be a need to include/enable an outgoing half echo control device in the circuit for the call, the network resource management message is passed to the succeeding exchange.

### 2.7.2.2.3 Action at the originating exchange

The actions at the originating exchange depend on the information received in the echo control device indicators in the backward call indicator in the address complete or connect message and the echo control information parameter in the address complete, connect, or network resource management message, and if there are any echo control devices available.

- a) If the echo control device indicator in the address complete or connect message is set to “incoming half echo control device not included”, the actions depend on whether the exchange has a note in memory that there may be a need to include/enable an incoming half echo control device in the circuit for the call or not.

If the exchange has a note in memory that there may be a need to include/enable an incoming half echo control device in the circuit for the call, the following actions are taken:

- An incoming half echo control device is included and if there is no incoming half echo control device, no special action is taken.
- b) If the echo control device indicator in the address complete or connect message is set to “incoming half echo control device included”, or the echo control information parameter in the network resource management message indicates that an incoming half echo control device is included, the actions depend on whether the exchange has included/enabled an incoming half echo control device for the call or not.
    - If the exchange has included/enabled an incoming half echo control device it shall release the incoming half echo control device.
    - If the exchange has not included/enabled an incoming half echo control device, no special action is taken.
  - c) If the echo control information parameter in the address complete, connect or network resource management message is indicating that an incoming half echo control device is requested, the actions are independent on whether the echo control device indicator in the backward call indicators parameter is set or not or the network resource management message indicates that an incoming half echo control device is included or not.

If there is an available half echo control device in the exchange, an incoming half echo control device is included.

If no incoming half echo control device is available in the exchange, no special action is taken.

- d) If the exchange receives in the echo control information parameter in the network resource management, address complete or connect message a request for an outgoing half echo control device, the action depends on whether an outgoing half echo control device is available or not.

If there are outgoing half echo control devices available, the following actions are taken:

- The exchange enables an outgoing half echo control device.
- If the echo control information parameter indicates that an outgoing half echo control device has been included at a succeeding exchange, a network resource management message is sent in the forward direction. The network resource management message indicates in the echo control information parameter that an outgoing half echo control device is included.

If there is no available echo control device, the actions taken depend on whether the echo control information parameter indicates that an outgoing half echo control device is included

- If the echo control information parameter indicates that an outgoing half echo control device is already included, then a network resource management message is sent in the forward direction indicating in the echo control information parameter that an outgoing half echo control device is not included.

- If the echo control information parameter indicates that an outgoing half echo control device is not already included, then no special action is taken.

### **2.7.2.3 Abnormal situations in an exchange which does not support the dynamic echo control procedure**

If an exchange has enabled an outgoing half echo control device and receives an echo control device indicator in the first backward message indicating that an incoming half echo control device is not included in a succeeding exchange, then the following actions are taken:

- The call is not cleared.
- The outgoing half echo control device is not disabled.
- The incoming half echo control device indicator is sent as received in intermediate exchanges.

If an exchange receives the information that an incoming half echo control device is included in the connection although an outgoing half echo control device is not enabled in this exchange or any preceding exchange, then the following actions are taken:

- The call is not cleared.
- The echo control device indicator is transferred transparently.

## **2.7.3 After address complete**

### **2.7.3.1 Echo control device activation**

Depending on which end of the call recognizes the need to invoke echo control activation procedures, the following procedures apply.

#### **2.7.3.1.1 Activation from the originating exchange**

##### **2.7.3.1.1.1 Actions at the originating exchange**

The actions at the originating exchange depend on whether the originating exchange is equipped with outgoing and/or incoming echo control devices.

If the originating exchange has outgoing half echo control devices available, the following actions occur:

- The outgoing half echo control device is included.
- The echo control information parameter in the network resource management message sent forward will indicate that an outgoing half echo control device is included.

If the originating exchange has no outgoing half echo control devices available, the following action occurs:

- The echo control information parameter in the network resource management message sent forward will indicate that no outgoing half echo control device is included and that an outgoing half echo control device is required.

If the originating exchange has incoming half echo control devices available, the following actions occur:

- The exchange notes in memory that there may be a need to include/enable an incoming half echo control device in the circuit for the call and timer T37 is started provided the exchange does not know that the succeeding exchanges will include an incoming half echo control device.
- The echo control information parameter in the network resource management message sent forward will indicate that an incoming half echo control device is included and that an incoming half echo control device is requested.

If the originating exchange has no incoming half echo control devices, the following action occurs:

- The echo control information parameter in the network resource management message sent forward will indicate that no incoming half echo control device is included and that an incoming half echo control device is requested.

If the originating exchange receives from the succeeding network the echo control information parameter in a network resource management message indicating that an incoming half echo control device has been included, the actions at the originating exchange depend on if the exchange has a note in memory that there may be a need to include/enable an incoming half echo control device in the circuit for the call.

If the originating exchange has a note in memory that there may be a need to include/enable an incoming half echo control device in the circuit for the call, it will release the incoming half echo control device and stop the timer T37.

If timer T37 expires, the incoming half echo control device is included.

If the exchange receives a backward network resource management message with the echo control information parameter set to indicate that an incoming half echo control device is not included, the actions depend on whether the exchange has a note in memory that there may be a need to include/enable an incoming half echo control device in the circuit for the call.

If this exchange has a note in memory that there may be a need to include/enable an incoming half echo control device in the circuit for the call, the device is included/enabled and timer T37 is stopped.

If the exchange has no note in memory that there may be a need to include/enable an incoming half echo control device in the circuit for the call, no special action is taken.

#### **2.7.3.1.1.2 Actions at an intermediate exchange**

The actions at an intermediate exchange depend on which information is received in the network resource management message and if the intermediate exchange is equipped with outgoing and/or incoming half echo control devices.

- a) If the intermediate exchange receives in the echo control information parameter in the network resource management message from the preceding exchange an indication that an outgoing half echo control device is included, it will release any outgoing half echo control device used for the call. The outgoing half echo control device response indicator is passed on unchanged. As the network resource management message, in this case, contains a request for an incoming half echo control device, the network resource management message is sent forward with the incoming half echo control device request indicator unchanged.
- b) If the intermediate exchange receives in the echo control information parameter in the network resource management message from the preceding exchange an indication that an outgoing half echo control device is required, the following actions occur depending on if outgoing half echo control devices are available or not.

If outgoing half echo control devices are available, the following actions occur:

- The outgoing half echo control devices included.
- The echo control information parameter in the network resource management message sent forward will indicate that an outgoing half echo control device is included and the outgoing half echo control device request indicator is set to “no information”.

If no outgoing half echo control devices are available, the following action occurs:

- The echo control information parameter in the network resource management message sent forward will be unchanged.

- c) If the intermediate exchange receives in the echo control information parameter in the network resource management message from the preceding exchange an indication that an incoming half echo control device is required, the following actions occur depending on if incoming half echo control devices are available or not.

If incoming half echo control devices are available, the following actions occur:

- The exchange notes in memory that there may be a need to include/enable an incoming half echo control device in the circuit for the call and timer T37 is started provided the exchange does not know that the succeeding exchanges will include an incoming half echo control device.
- The echo control information parameter in the network resource management message sent forward will indicate that an incoming half echo control device is included and that an incoming half echo control device is requested.

If the echo control information parameter indicates that an incoming half echo control device has been included at a preceding exchange, a network resource management message is sent in the backward direction indicating in the echo control information parameter that an incoming half echo control device included.



If no incoming half echo control devices are available, the following action occurs:

- The echo control information parameter in the network resource management message sent forward will be unchanged.
- d) If the intermediate exchange receives from the succeeding exchange the echo control information parameter in a network resource management message indicating that an incoming half echo control device has been included, the actions at the intermediate exchange depend on if the exchange has a note in memory that there may be a need to include/enable an incoming half echo control device in the circuit for the call or not.

If the exchange has a note in memory that there may be a need to include/enable an incoming half echo control device in the circuit for the call, it will release the incoming half echo control device and timer T37 is stopped.

If the exchange has no note in memory that there may be a need to include/enable an incoming half echo control device in the circuit for the call, the network resource management message will be sent backward to the preceding exchange.

- e) If the exchange receives a backward network resource management message with the echo control information parameter set to indicate that an incoming half echo control device is not included, the actions depend on whether this exchange has a note in memory that there may be a need to include/enable an incoming half echo control device in the circuit for the call.

If the exchange has a note in memory that there may be a need to include/enable an incoming half echo control device in the circuit for the call, the device is included/enabled and timer T37 is stopped. The network resource management message is not sent to the preceding exchange.

If the exchange has no note in memory that there may be a need to include/enable an incoming half echo control device in the circuit for the call, the network resource management message is passed to the preceding exchange.

- f) If timer T37 expires, the incoming half echo control device is included/enabled.

#### **2.7.3.1.1.3 Actions at the destination exchange**

The actions at the destination exchange depend on which information is received in the echo control information parameter in the network resource management message and if the destination exchange is equipped with outgoing and/or incoming half echo control devices.

- a) If the destination exchange receives from the preceding exchange in the echo control information parameter in the network resource management message an indication that an outgoing half echo control device is included, it will release any outgoing half echo control device used for the call and sent the received network resource management message forward.
- b) If the destination exchange receives from the preceding exchange in the echo control information parameter in the network resource management message an indication that an outgoing half echo control device is required, the following actions occur depending on if outgoing half echo control devices are available or not.

If outgoing half echo control devices are available, the following action occurs:

- The outgoing half echo control device is included.

If no outgoing half echo control devices are available, no special action is taken.

- c) If the destination exchange receives from the preceding exchange in the echo control information parameter in the network resource management message an indication that an incoming half echo control device is required, the following actions occur depending on if incoming half echo control devices are available or not.

If incoming half echo control devices are available, the following actions occur:

- The incoming half echo control device is included.
- A network resource management message with the echo control information parameter set to “incoming half echo control device included” is sent backward to the preceding exchange, if the network resource management message received indicated that an incoming half echo control device was included.

If there is no available incoming half echo control device, the actions depend on whether the network resource management message indicates that an incoming half echo control device is included.

If the network resource management message indicates that an incoming half echo control device is already included, then a network resource management message is sent in the backward direction indicating in the echo control information parameter that an incoming half echo control device is not included.

If the network resource management message indicates that an incoming half echo control device is not already included, no special action is taken.

### **2.7.3.1.2 Activation from the destination exchange**

#### **2.7.3.1.2.1 Actions at the destination exchange**

The actions at the destination exchange depend on whether the exchange is equipped with outgoing and/or incoming half echo control devices.

If the exchange has incoming half echo control devices available, the following actions occur:

- The incoming half echo control device is included.
- The echo control information parameter in the network resource management message sent backward will indicate that an incoming half echo control device is included.

If the destination exchange has no incoming half echo control devices available, the following action occurs:

- The echo control information parameter in the network resource management message sent backward will indicate that an incoming half echo control device is not included and that an incoming half echo control device is requested.

If the destination exchange has an outgoing half echo control device available, it will note in memory that there may be a need to include/enable an outgoing half echo control device in the circuit and timer T37 is started. A network resource management message is sent to the preceding exchange indicating that an outgoing half echo control device is included/enabled and an outgoing half echo control device is requested.

If the destination exchange receives from the preceding exchange the echo control information parameter in a network resource management message indicating that an outgoing half echo control device has been included, the actions at the destination exchange depend on if the exchange has a note in memory that there may be a need to include/enable an outgoing half echo control device in the circuit for the call or not.

If the exchange has a note in memory that there may be a need to include/enable an outgoing half echo control device in the circuit for the call, it will release the outgoing half echo control device and timer T37 is stopped.

If the exchange has no note in memory that there may be a need to include/enable an outgoing half echo control device in the circuit for the call, no special action occurs.

If timer T37 expires, the outgoing half echo control device is included.

If the exchange receives a forward network resource management message with the echo control information parameter set to indicate that an outgoing half echo control device is not included, the actions depend on whether the exchange has a note in memory that there may be a need to include/enable an outgoing half echo control device in the circuit for the call.

If the exchange has a note in memory that there may be a need to include/enable an outgoing half echo control device in the circuit for the call, the device is included/enabled and timer T37 is stopped.

If the exchange has no note in memory that there may be a need to include/enable an outgoing half echo control device in the circuit for the call, no special action is taken.

#### **2.7.3.1.2.2 Actions at an intermediate exchange**

The actions at an intermediate exchange depend on which information is received in the echo control information parameter in the network resource management message and if the intermediate exchange is equipped with outgoing and/or incoming half echo control devices.

- a) If the exchange receives from the succeeding exchange in the echo control information parameter in the network resource management message an indication that an incoming half echo control device is included, it will release any incoming half echo control devices used for the call. The incoming half echo control device response indicator is passed on unchanged. As the network resource management message, in this case, contains a request for an outgoing half echo control device, the network resource management message is sent backward with the outgoing half echo control device request indicator unchanged.

- b) If the exchange receives from the succeeding exchange in the echo control information parameter in the network resource management message an indication that an incoming half echo control device is required, the following actions occur depending on if incoming half echo control devices are available or not.

If incoming half echo control devices are available, the following actions occur:

- The incoming half echo control device is included.
- The echo control information parameter in the network resource management message sent backward will indicate that an incoming half echo control device is included and the incoming half echo control device request indicator is set to “no information”.

If no incoming half echo control devices are available, the following action occurs:

- The echo control information parameter in the network resource management message sent backward will be unchanged.

- c) If the exchange receives from the succeeding exchange in the echo control information parameter in the network resource management message in indication that an outgoing half echo control device is requested, the following actions occur depending on whether outgoing half echo control devices are available or not.

If outgoing half echo control devices are available, the following actions occur:

- The exchange notes in memory that there may be a need to include/enable an outgoing half echo control device in the circuit for the call and timer T37 is started, provided the exchange does not know that the preceding exchanges will include an outgoing half echo control device.
- The echo control information parameter in the network resource management message sent backward will indicate that an outgoing half echo control device is requested and that an outgoing half echo control device is included.

If the received echo control information parameter indicates that an outgoing half echo control device has been included at a succeeding exchange, a network resource management message is sent in the forward direction indicating in the echo control information parameter that an outgoing half echo control device is included.

If no outgoing half echo control devices are available, the following action occurs:

- The echo control information parameter in the network resource management message sent backward will be unchanged.

- d) If the exchange receives from the preceding exchange the echo control information parameter in a network resource management message indicating that an outgoing half echo control device has been included at a preceding exchange, the actions at the intermediate exchange depend on if the exchange has a note in memory that there may be a need to include/enable an outgoing half echo control device in the circuit for the call or not.

If the exchange has a note in memory that there may be a need to include/enable an outgoing half echo control device in the circuit for the call, it will release the outgoing half echo control device and timer T37 is stopped. The network resource management message is not sent to the succeeding exchange.

If the exchange has no note in memory that there may be a need to include/enable an outgoing half echo control device in the circuit for the call, the network resource management message will be sent forward to the succeeding exchange.

- e) If the exchange receives a forward network resource management message with the echo control information parameter set to indicate that an outgoing half echo control device is not included, the actions depend on whether the exchange has a note in memory that there may be a need to include/enable an outgoing half echo control device in the circuit for the call.

If the exchange has a note in memory that there may be a need to include/enable an outgoing half echo control device in the circuit for the call, the device is enabled and timer T37 is stopped. The network resource management message is not sent to the succeeding exchange.

If the exchange has no note in memory that there may be a need to include/enable an outgoing half echo control device in the circuit for the call, the network resource management message is passed to the succeeding exchange.

- f) If timer T37 expires, the outgoing half echo control device is included/enabled.

### 2.7.3.1.2.3 Actions at the originating exchange

The actions at the originating exchange depend on which information is received in the echo control information parameter in the network resource management message and if the originating exchange is equipped with outgoing and/or incoming half echo control devices.

- a) If the originating exchange receives in the echo control information parameter in the network resource management message an indication that an incoming half echo control device is included, it will release any incoming half echo control devices used for the call and send the received network resource management message backward.
- b) If the originating exchange receives in the echo control information parameter in the network resource management message an indication that an incoming half echo control device is requested, the following actions occur depending on if incoming half echo control devices are available or not.

If incoming half echo control devices are available, the following action occurs:

- The incoming half echo control device is included.

If no incoming half echo control devices are available, no special action is taken.

- c) If the originating exchange receives in the echo control information parameter in the network resource management message an indication that an outgoing half echo control device is requested, the following actions occur depending on if outgoing half echo control devices are available or not.

If outgoing half echo control devices are available, the following actions occur:

- The outgoing half echo control device is included.
- A network resource management message with the echo control information parameter set to “outgoing half echo control device included” is sent forward to the succeeding exchange, if the network resource management message received before indicated that an outgoing half echo control device was already included.

If there is no available echo control device, the actions depend on whether the network resource management message indicates that an outgoing half echo control device is included.

If the network resource management message indicates that an outgoing half echo control device is already included, a network resource management message is sent in the forward direction indicating in the echo control information parameter that an outgoing half echo control device is not included.

If the network resource management message indicates that an outgoing half echo control device is not already included, no special action is taken.

### 2.7.3.2 Echo control device deactivation

Depending on which end of the call recognizes a need to invoke echo control deactivation procedure, the following procedures apply.

#### 2.7.3.2.1 Deactivation from the originating exchange

##### 2.7.3.2.1.1 Actions at the originating exchange

The actions at the originating exchange depend on whether the originating exchange has included an outgoing and/or incoming half echo control device.

If the exchange has included an outgoing half echo control device, the following actions occur:

- The outgoing half echo control device is released.
- The echo control information parameter in the network resource management message sent forward will indicate a request that an outgoing half echo control device shall be deactivated.

If the originating exchange has no outgoing half echo control devices available, the following action occurs:

- The echo control information parameter in the network resource management message sent forward will indicate a request that an outgoing half echo control device shall be deactivated.

If the originating exchange has included an incoming half echo control device, the following actions occur:

- The incoming half echo control device is deactivated.
- The echo control information parameter in the network resource management message sent forward will indicate a request that an incoming half echo control device shall be deactivated.

If the originating exchange has no incoming half echo control devices available, the following action occurs:

- The echo control information parameter in the network resource management message sent forward will indicate a request that an incoming half echo control device shall be deactivated.

#### **2.7.3.2.1.2 Actions at an intermediate exchange**

The actions at an intermediate exchange depend on which information is included in the echo control information parameter in the network resource management message and if the intermediate exchange has an outgoing and/or incoming half echo control device for the call.

- a) If the intermediate exchange receives from the preceding exchange in the echo control information parameter in the network resource management message a request that an outgoing half echo control device shall be deactivated, the following actions occur depending on if outgoing half echo control devices are included for the call or not.

If outgoing half echo control devices are included for the call, the following actions occur:

- The outgoing half echo control device is released.
- The echo control information parameter in the network resource management message is sent forward as received.

If no outgoing half echo control device is available, the following action occurs:

- The echo control information parameter in the network resource management message is sent forward as received.

- b) If the intermediate exchange receives from the preceding exchange in the echo control information parameter in the network resource management message a request that an incoming half echo control device shall be deactivated, the following actions occur depending on if incoming half echo control devices are included for the call or not.

If an incoming half echo control device is included for the call, the following actions occur:

- The incoming half echo control device is deactivated.
- The echo control information parameter in the network resource management message is sent forward as received.

If no incoming half echo control device is available for the call, the following action occurs:

- The echo control information parameter in the network resource management message is sent forward as received.

#### **2.7.3.2.1.3 Actions at the destination exchange**

The actions at the destination exchange depend on which information is received in the echo control information parameter in the network resource management message and if the destination exchange has included an outgoing and/or incoming half echo control device for the call.

- a) If the destination exchange receives from the preceding exchange in the echo control information parameter in the network resource management message a request that an outgoing half echo control device shall be deactivated, the actions depend on if it has included an outgoing half echo control device for the call or not.

If an outgoing half echo control device is included, the following action occurs:

- The outgoing half echo control device is deactivated.

If no outgoing half echo control device is included, no special action is taken.

- b) If the destination exchange receives from the preceding exchange in the echo control information parameter in the network resource management message a request that an incoming half echo control device shall be deactivated, the following actions occur depending on if an incoming half echo control device is included for the call or not.

If an incoming half echo control device is included, the following action occurs:

- The incoming half echo control device is deactivated.

If no incoming half echo control devices are available, no special action occurs.

### **2.7.3.2.2 Deactivation from the destination exchange**

#### **2.7.3.2.2.1 Actions at the destination exchange**

The actions at the destination exchange depend on whether the destination exchange has included outgoing and/or incoming half echo control device for the call.

If the destination exchange has outgoing half echo control devices included, the following actions occur:

- The outgoing half echo control device is released.
- The echo control information parameter in the network resource management message sent backward will indicate a request that an outgoing half echo control device shall be deactivated.

If the destination exchange has no outgoing half echo control device available, the following action occurs:

- The echo control information parameter in the network resource management message sent backward will indicate a request that an outgoing half echo control device shall be deactivated.

If the destination exchange has included an incoming half echo control device, the following actions occur:

- The incoming half echo control device is released.
- The echo control information parameter in the network resource management message sent backward will indicate a request that an incoming half echo control device shall be deactivated.

If the destination exchange has no incoming half echo control device available, the following action occurs:

- The echo control information parameter in the network resource management message sent backward will indicate a request that an incoming half echo control device shall be deactivated.

#### **2.7.3.2.2.2 Actions at an intermediate exchange**

The actions at the intermediate exchange depend on which information is received in the echo control information parameter in the network resource management message and if the exchange has included an outgoing and/or incoming half echo control device for the call.

- a) If the intermediate exchange receives from the succeeding exchange in the echo control information parameter in the network resource management message a request that an outgoing half echo control device shall be deactivated, the following actions occur depending on if outgoing half echo control devices are included for the call or not.

If outgoing half echo control devices are included for the call, the following actions occur:

- The outgoing half echo control device is released.
- The echo control information parameter in the network resource management message is sent backward as received.

If no outgoing half echo control device is available, the following action occurs:

- The echo control information parameter in the network resource management message is sent backward as received.

- b) If the intermediate exchange receives from the succeeding exchange in the echo control information parameter in the network resource management message a request that an incoming half echo control device shall be deactivated, the following actions occur depending on if incoming half echo control devices are included for the call or not.

If incoming half echo control devices are included, the following actions occur:

- The incoming half echo control device is deactivated.
- The echo control information parameter in the network resource management message is sent backward as received.

If no incoming echo control device is available, the following action occurs:

- The echo control information parameter in the network resource management message is sent backward as received.

#### **2.7.3.2.2.3 Actions at the originating exchange**

The actions at the originating exchange depend on which information is received in the echo control information parameter in the network resource management message and if the originating exchange has included an outgoing and/or incoming half echo control device for the call.

- a) If the originating exchange receives from the succeeding exchange in the echo control information parameter in the network resource management message a request that an outgoing half echo control device shall be deactivated, the actions depend on if it has included an outgoing half echo control device for the call or not.

If an outgoing half echo control device is included, the following action occurs:

- The outgoing half echo control device is deactivated.

If no outgoing half echo control device is included, no special action is taken.

- b) If the originating exchange receives from the succeeding exchange in the echo control information parameter in the network resource management message a request that an incoming half echo control device shall be deactivated, the actions depend on if it has included an incoming half echo control device for the call or not.

If an incoming half echo control device is included, the following action occurs:

- The incoming half echo control device is deactivated.

If no incoming half echo control device is included, no special action occurs.

## **2.8 Network features**

### **2.8.1 Automatic repeat attempt**

Automatic repeat attempt, as defined in Recommendation Q.12, is provided in Signalling System No. 7. An automatic repeat attempt will be made (up to the point when the initial address message information is released, see 2.3.4):

- i) on detection of dual seizure (at the non-control exchange) (see 2.9.1.4);
- ii) on receipt of the blocking message after sending an address message and before any backward message has been received (see 2.8.2);
- iii) on receipt of a reset circuit message after sending an address message and before a backward message has been received [see 2.9.3.1 e)];
- iv) on failure of continuity-check, when a continuity check is performed;
- v) on receipt of an unreasonable message during call set up (see 2.9.5).

### **2.8.2 Blocking and unblocking of circuits and circuit groups**

The blocking (unblocking) message and the circuit group blocking (unblocking) message are provided to permit the switching equipment or maintenance system to remove from (and return to) traffic the distant terminal(s) of a circuit or group of circuits because of a fault or to permit testing.

Since the circuits served by the ISDN User Part have both-way capability, the blocking message or circuit group blocking message can be originated by either exchange. The receipt of a blocking message or a circuit group blocking message will have the effect of prohibiting non test calls on the relevant circuit(s) outgoing from the exchange until an unblocking message or an appropriate circuit group unblocking message is received, but will not prohibit test calls incoming to that exchange. Test calls generated in the outgoing direction from the exchange that sent the blocking or circuit group blocking message will also be processed. Non-test initial address messages will result in an abnormal case

[see 2.8.2.3 xiv)]. An acknowledgement sequence is always required for the blocking and unblocking message as well as for the circuit group blocking message and circuit group unblocking messages using the blocking acknowledgement message, the unblocking acknowledgement message, the appropriate circuit group blocking acknowledgement messages and the appropriate circuit group unblocking acknowledgement message respectively. The acknowledgement is not sent until the appropriate action – either blocking or unblocking – has been taken. The release message should not override a blocking message and return circuits to service which might be faulty. The blocked circuit(s) will be returned to service on transmission of the unblocking acknowledgement message or the appropriate circuit group unblocking acknowledgement message at one exchange and on receipt of the unblocking acknowledgement message or the appropriate circuit group unblocking acknowledgement message at the other exchange.

The use of circuits for multirate calls has no effect on the blocking (unblocking) procedures, which apply on a per circuit, not per call basis.

### **2.8.2.1 Other actions on receipt of a blocking message**

In the event of a blocking message being received, after an initial address message has been sent in the opposite direction on that circuit, and before a backward message relating to that call has been received, an automatic repeat attempt will be made on another circuit. The exchange receiving the blocking message releases the original call attempt in the normal manner after sending the blocking acknowledgement message and will not seize that circuit for subsequent calls.

If the blocking message is received:

- after an initial address message has been sent for that circuit in the opposite direction and after at least one backward message relating to that call has been received; or
- after an initial address message has been received for that circuit beforehand,

the exchange will not seize that circuit for subsequent calls, and the current call proceeds.

The fact that the circuit is engaged on a call will not delay transmission of the blocking (unblocking) acknowledgement message.

If a blocking message is sent and subsequently an initial address message is received in the opposite direction, the following action is taken:

- for test calls, the call should be accepted, if possible. In the case where the test call cannot be accepted, the blocking message must be returned;
- for calls other than test calls, the blocking message must be returned and the initial address message discarded.

When a circuit is blocked by use of the blocking message, the maintenance system should be informed at both ends of the circuit.

### **2.8.2.2 Circuit group blocking and unblocking messages**

The following circuit group blocking (unblocking) messages and their corresponding acknowledgement messages are provided:

- maintenance oriented circuit group blocking (unblocking) message;
- hardware failure oriented circuit group blocking (unblocking) message;

The circuits to be blocked (unblocked) are indicated in the status field.

The maximum number of circuits to be blocked (unblocked) with one circuit group blocking (unblocking) message is limited to 32.

A received circuit group blocking (unblocking) acknowledgement message has to match in the parameter value of the circuit identification code, the circuit group supervision message type indicator, and the range field (see Recommendation Q.763) with the previously sent group blocking (unblocking) message in order to be considered a valid acknowledgement.

A circuit is controlled by the ISDN User Part if it can be used by the ISDN User Part as a circuit switched bearer. Hence, time slots in a digital path that are used for synchronization (e.g. time slot 0 in a 2048 kbit/s digital path) or as signalling channels are not circuits whose control is allocated to the ISDN User Part.



Some of the circuit identification code values covered by the range field of a circuit group blocking/unblocking (acknowledgement) message may not be allocated to any circuit. Then the corresponding status bits in the status field are set to 0. This is not allowed for the circuit identification code values related to status bits being set to 1. Those circuit identification code values must always be allocated to circuits whose control is allocated to the ISDN User Part. In particular, the circuit identification code value indicated in the label of a message must be allocated to a circuit.

The maintenance oriented circuit group blocking (unblocking) procedures set (remove) the same blocking states as the blocking (unblocking) procedures. This means that a blocking state set by a maintenance oriented circuit group blocking message or indicated as blocked for maintenance purposes in the status field of a circuit group reset acknowledgement message can be removed by an unblocking message. Similarly, a blocking state set by a blocking message can be removed by a maintenance oriented circuit group unblocking message.

The maintenance blocked state set by maintenance oriented circuit group blocking message, by a status indicator in a circuit group reset acknowledgement message or a blocking message, cannot be removed by a hardware oriented circuit group unblocking message.

The range of circuits to be blocked (unblocked) is indicated in the range field. Those circuits within the range that have to be blocked (unblocked) are indicated in the status field. The same rule applies to the acknowledgements.

For the circuits blocked for maintenance reasons, the same conditions apply and the same actions have to be taken as described in 2.8.2.1.

For the circuits seized by ongoing calls or call attempts and blocked for reasons of hardware failure, the following actions will be taken:

- all interconnected circuits have to be released by the appropriate messages;
- the affected circuits are set to the condition “idle hardware blocked ”without any exchange of release messages.

The fact that a circuit is engaged on a call will not delay the transmission of the corresponding circuit group blocking (unblocking) acknowledgement message.

The hardware blocked state can only be removed by a hardware failure oriented circuit group unblocking message.

For all instances of circuit group blocking, the maintenance system should be notified at both ends of the circuit(s).

### **2.8.2.3 Abnormal blocking and circuit group blocking procedures**

The following procedures are designed to cover abnormal cases which may occur in the circuit group blocking/unblocking procedures:

- i) If a circuit group blocking message is received relating to remotely blocked circuits, then blocking acknowledgement indications for those circuits are given in the status field of the corresponding circuit group blocking acknowledgement message which will be sent in response.
- ii) If a circuit group unblocking message is received relating to circuits which are not in the state remotely blocked, then unblocking acknowledgement indications for those circuits are given in the status field of the corresponding circuit group unblocking acknowledgement message which will be sent in response.
- iii) When an exchange upon receipt of a circuit group blocking (unblocking) message is not able to give an appropriate blocking (unblocking) acknowledgement indication for each circuit identification code (e.g. because that/those circuit identification code(s) is(are) not allocated to any circuit at the receiving exchange) for which also a blocking (unblocking) indication is given in the status field of the received group blocking (unblocking) message, then no blocking (unblocking) acknowledgement indication relating to that/those circuit identification code(s) will be given in the status field of the corresponding circuit group blocking (unblocking) acknowledgement message which will be sent in response.
- iv) If a circuit group blocking acknowledgement message in response to a circuit group blocking message is received containing in the status field the indications no blocking acknowledgement for the circuits which are to be blocked due to the previously sent circuit group blocking message, then the maintenance system should be notified for the concerned circuits. The same rule applies to the unblocking procedures.

- v) If a circuit group blocking acknowledgement message in response to a circuit group blocking message is received containing in the status field blocking acknowledgement indications for the circuits which are not to be blocked due to the previously sent circuit group blocking message and are not marked locally blocked, then the maintenance system should be notified for the circuits concerned.
- vi) If a circuit group unblocking acknowledgement message in response to a group unblocking message is received containing in the status field unblocking acknowledgement indications for circuits which are not to be unblocked due to the previously sent circuit group unblocking message and have to remain marked locally blocked, then the maintenance system should be notified for the circuits concerned.
- vii) If a circuit group blocking acknowledgment message, which is not expected as an acknowledgment for any circuit group blocking message, is received:
  - relating to circuits which all are in the status locally blocked, the received circuit group blocking acknowledgement will be discarded;
  - relating to circuits part or all of which are not in the status locally blocked, then the maintenance system should be notified for the relevant circuits.
- viii) If a circuit group unblocking acknowledgement message, which is not expected as an acknowledgement for any circuit group unblocking message, is received:
  - relating to circuits none of which is in the status locally blocked, then the circuit group unblocking acknowledgement message will be discarded;
  - relating to circuits part or all of which are locally blocked, then the maintenance system should be notified for the relevant circuits.
- ix) If a circuit group blocking (unblocking) message or a circuit group blocking (unblocking) acknowledgement message refers to status changes for more than 32 circuits, the receiving exchange shall discard that message.
- x) If a blocking message is received for a blocked circuit, a blocking acknowledgement message will be sent.
- xi) If an unblocking message is received for an unblocked circuit, an unblocking acknowledgement message will be sent.
- xii) If a blocking acknowledgement message, which is not expected as an acknowledgement for a blocking message, is received:
  - relating to a circuit which is locally blocked, the blocking acknowledgement message is discarded;
  - relating to a circuit which is not locally blocked, then the maintenance system should be notified;
- xiii) If an unblocking acknowledgement message, which is not an expected response to an unblocking message, is received:
  - relating to a circuit which is not locally blocked, the received unblocking acknowledgement message is discarded;
  - relating to a circuit which is locally blocked, then the maintenance system should be notified.
- xiv) If a non test initial address message is received on a remotely blocked circuit, the remotely blocked state of the circuit is removed and the initial address message is processed normally unless the circuit is also locally blocked in which case the initial address message is discarded. This applies to the blocking state whether maintenance, hardware or both. However it should not be the preferred method of unblocking a circuit.
- xv) When an exchange receives a circuit group blocking (unblocking) acknowledgement message which indicates circuits that are not under ISDN User Part control (except for the circuit in the label of the message), these circuits will be ignored.

### **2.8.3 Circuit group query (national use)**

#### **2.8.3.1 General**

The circuit group query test allows an exchange to audit the state of a circuit on a demand or routine basis.

The value N of the range field of the circuit group query message, including N = 0 for a single circuit, indicates the range to be tested. The maximum value of N is 31. If that value is exceeded, the circuit group query message is discarded.

### 2.8.3.2 Interpretation of circuit states

For the purposes of circuit query procedures, there are states which are classified into four major categories, as follows:

- 1) unequipped and transient conditions;
- 2) call processing states;
- 3) maintenance blocking states;
- 4) hardware blocking states.

The two states “unequipped” and “transient” do not overlap with other states.

Call processing states include:

- 1) idle;
- 2) circuit incoming busy;
- 3) circuit outgoing busy.

Maintenance blocking states include:

- 1) unblocked;
- 2) remotely blocked;
- 3) locally blocked;
- 4) locally and remotely blocked.

Hardware blocking states include:

- 1) unblocked;
- 2) remotely blocked;
- 3) locally blocked;
- 4) locally and remotely blocked.

A circuit is “unequipped” if the circuit is not available for ISDN User Part. Call processing or maintenance action cannot be performed on it. This is a unique state and will not overlap with any other state.

The “transient” state refers to any transient call processing or maintenance states.

Call processing is in a transient state

- a) after having sent an initial address message and waiting for the first backward message (whether a suspended call is in a transient state in the context of circuit group query is for further consideration); or
- b) after having sent a release message and waiting for the release complete message.

Transient maintenance states are those where the exchange, after having sent a(group) (un)blocking message, is awaiting the proper (group) (un)blocking acknowledgement message from the remote exchange.

The circuit state is also considered transient as long as a circuit (group)reset message has not been acknowledged.

The “idle” state is a call-processing state of an equipped, non-busy circuit. The “circuit incoming busy” or “circuit outgoing busy” refers to a stable call processing state.

The hardware or maintenance “remotely blocked” state refers to the state marked by the exchange when the far-end exchange initiates blocking. The maintenance blocking state can co-exist with “idle”, “circuit incoming busy”, or “circuit outgoing busy” state. The hardware blocking state can only co-exist with the “idle” call processing state, as calls are immediately released when hardware blocking is invoked.

The hardware or maintenance “locally blocked” state refers to the state marked by the exchange when it initiated blocking to the far-end exchange and the proper acknowledgement was received. The maintenance blocking state can coexist with “idle”, “circuit incoming busy”, or “circuit outgoing busy” state. The hardware blocking state can only coexist with the “idle” call processing state, as calls are immediately released when hardware blocking is invoked.

To initiate the circuit group query procedure, the sending exchange sends a circuit group query message indicating in the routing label and range field those circuits to be audited. If no response to the circuit group query message is received before timer T28 expires, maintenance systems should be informed.

The receiving exchange will process the circuit group query message, and return a circuit group query response message setting the circuit state indicators to the state of the circuits being audited.

If this circuit group procedure uncovers discrepancies in the state of a circuit as perceived at the two ends, the actions to be taken in order to align the two views are for further study.

## **2.9 Abnormal conditions**

### **2.9.1 Dual seizure**

Because Signalling System No. 7 circuits have the capability of bothway operation, it is possible that the two exchanges will attempt to seize the same circuit at approximately the same time.

#### **2.9.1.1 Unguarded interval**

The exchange must detect dual seizure and take action as defined in 2.9.1.4.

#### **2.9.1.2 Detection of dual seizure**

A dual seizure is detected by an exchange from the fact that it receives an initial address message for a circuit for which it has sent an initial address message, but before it receives a valid backwards message.

As a circuit group may handle a mixture of 64 kbit/s and multirate connection types, dual seizure by calls of different connection types is possible. In this case the initial address messages may have different circuit identification codes.

#### **2.9.1.3 Preventive action**

Different methods for circuit selection can be envisaged to minimize the occurrence of dual seizure. In the following, two methods are described. For bothway circuit groups supporting multirate connection types, method 1 only (described below) should be used. For bothway circuit groups not supporting multirate connection types, either method 1 or 2 may be used. Further study is required to determine the field of application of each method and to ensure that the two methods do inter-work satisfactorily.

Other methods for circuit selection may also be used provided that they give the same degree of protection against dual seizure also when one of the methods specified is used at the other end.

##### **Method 1**

An opposite order of selection is used at each exchange of a bothway circuit group.

##### **Method 2**

Each exchange of a bothway circuit group has priority access to the group of circuits which it is controlling (see 2.9.1.4). Of this group, the circuit which has been released the longest is selected (first-in, first-out). In addition, each exchange of a bothway circuit group has non-priority access to the group of circuits which it is non-controlling. Of this group, the latest released circuit is selected (last-in, first-out) if all circuits in the group are busy.

It is necessary to take preventive action in cases where Signalling System No. 7 uses a signalling data link with long propagation time.

#### **2.9.1.4 Action to be taken on detection of dual seizures**

In the event of dual seizure, one exchange will be the control exchange and the other the non-control exchange. On detection of a dual seizure, the call being processed by the control exchange will be completed and the received initial address message will be disregarded. If the initial address message has been segmented using a segmentation message, then this second segment will also be disregarded.

Under these conditions, the call being processed by the control exchange will be allowed to mature. The call being processed by the non-control exchange will be backed off and the switch-path released. A release message will not be sent. The non-control exchange will make an automatic repeat attempt on the same or on an alternative route.

The control exchange will be determined as follows:

a) *Where neither call involved is a multirate connection type*

Each exchange will control one half of the circuits in a bothway circuit group the exchange with the higher signalling point code will control all even-numbered circuits (circuit identification code) and the other exchange the odd-numbered circuits.

b) *Where the calls involved are of different connection types*

The exchange processing the call involving the greater number of 64 kbit/s circuits will be the control exchange.

c) *Where both calls are of the same multirate connection type*

The circuit identification code used in the initial address message shall be divided by the number of 64 kbit/s circuits required by the call; if the result is even then the exchange with the higher signalling point code will control and the other exchange will control if the result is odd.

#### **2.9.2 Transmission alarm handling for digital inter-exchange circuits**

When fully digital circuits are provided between two exchanges, which have some inherent fault indication feature giving an indication to the switching system when faults on transmission systems are detected, the switching system should inhibit selection of the circuits concerned for the period the fault conditions persist.

#### **2.9.3 Reset of circuits and circuit groups**

In systems which maintain circuit status in memory there may be occasions when the memory becomes mutilated. In such a case the circuits must be reset to the idle condition at both exchanges to make them available for new traffic. Since the exchange with the mutilated memory does not know whether the circuits are idle, busy outgoing, busy incoming, blocked, etc., reset circuit messages or a circuit group reset message should be sent as appropriate for the affected circuits.

##### **2.9.3.1 Reset circuit message**

If only a few circuits are concerned, a reset circuit message should be sent for each affected circuit.

On receipt of a reset circuit message, the receiving (unaffected) exchange will:

- a) if it is the incoming or outgoing exchange on a connection in any state of call set-up or during a call, accept the message as a release message and respond by sending a release complete message, after the circuit has been made idle;
- b) if the circuit is in the idle condition, accept the message as a release message and respond by sending a release complete message;
- c) if it has previously sent a blocking message, or if it is unable to release the circuit as described above, respond by the blocking message. If an incoming or outgoing call is in progress, this call should be released and the circuit returned to the "idle, blocked" state. A release complete message is sent following the blocking message. The blocking message should be acknowledged by the affected exchange. If the acknowledgement is not received, the repetition procedure specified in 2.9.4 should be followed;
- d) if it has previously received a blocking message, respond by releasing a possible outgoing call or call attempt on the circuit, remove the blocked condition, restore the circuit to the idle state, and respond with a release complete message;
- e) if the message is received after the sending of an initial address message but before receipt of a backward message relating to that call, clear the circuit and make an automatic repeat attempt on another circuit if appropriate;

- f) if the message is received after having sent a reset circuit message, respond by a release complete message. After receipt of the appropriate acknowledgement message, the circuit should be made available for service;
- g) clear any interconnected circuits by the appropriate method (e.g. release);
- h) when the reset circuit message identifies a circuit being used by a multirate connection type call, in addition, in order to make idle all circuits used for the call but not indicated in the reset circuit message, send reset circuit messages (or circuit group reset messages) for those circuits to the affected exchange. Alternatively, the exchange receiving the reset message may, before completing the reset procedure, clear those circuits used for the call but not indicated in the reset message, using the normal release procedure.

The affected exchange will then reconstruct its memory according to the received response(s) to the reset circuit and respond to the message(s) in the normal way, i.e. blocking acknowledgement message in response to a blocking message.

If no release complete message is received in acknowledgement to the reset circuit message before 15-60 seconds (T16), the reset circuit message should be repeated. If an acknowledgement for the message is not received within 5-15 minutes (T17) after the initial reset circuit message, the maintenance system should be notified. However, the sending of the reset circuit message should continue at 5-15 minutes (T17) intervals until maintenance intervention occurs.

### **2.9.3.2 Circuit group reset message**

If a considerable number of circuits or all circuits are affected by a memory mutilation, (a) circuit group reset message(s) should be used to make them available for new traffic.

The maximum number of circuits to be reset with a circuit group reset message is limited to 32.

On receipt of a circuit group reset message, the receiving (unaffected) exchange will:

- a) restore the circuits to the idle state;
- b) send the appropriate circuit group blocking message(s) if it had previously sent a hardware failure oriented circuit group blocking message;
- c) respond by a circuit group reset acknowledgement message in which the status indicator bits of the circuits available for service or blocked for reasons of hardware failure are coded 0 and the status indicator bits of all circuits blocked for maintenance reasons are set to 1;
- d) if it had previously received (a) blocking message(s) or (a) circuit group blocking message(s) for one or more of the circuit(s) involved, the blocked condition will be removed and the circuits will be made available for service;
- e) if a circuit group reset message is received concerning circuits for which a circuit group reset message or reset circuit message(s) have been sent, the circuits concerned are made available for service after receipt of the appropriate acknowledgement message;
- f) appropriate messages should be sent on interconnected circuits to release them;
- g) when the circuit group reset message identifies circuits being used by a multirate connection type call, in addition, in order to make idle all circuits used for the call but not indicated in the circuit group reset message, send reset circuit messages (or circuit group reset messages) for those circuits to the affected exchange. Alternatively, the exchange receiving the reset message may, before completing the reset procedure, clear those circuits used for the call but not indicated in the reset message, using the normal release procedure.

The affected exchange will then reconstruct its memory according to the possibly received circuit group blocking messages and the received circuit group reset acknowledgement message. It will respond to the possibly received circuit group blocking messages in the normal way.

If no acknowledgement to a circuit group reset message is received before 15-60 seconds (T22), the circuit group reset message should be repeated. If an acknowledgement for the circuit group reset message is not received within 5-15 minutes (T23) after sending the initial circuit group reset message, the maintenance system should be notified. However, the sending of the circuit group reset message should continue at 5-15 minutes (T23) intervals until maintenance intervention occurs.

A correct acknowledgement should match the original circuit group reset message in range and circuit identification code indicated in the routing label. The circuit identification code in the routing label of both circuit group reset messages and circuit group reset acknowledgement messages should belong to a circuit whose control is allocated to the ISDN User Part.

All circuit identification codes in the range of a circuit group reset and circuit group reset acknowledgement message must belong to circuits whose control is allocated to the ISDN User Part.

### **2.9.3.3 Abnormal circuit group reset message procedures**

- i) If a circuit group reset message is received indicating reset of more circuits than allowed by the receiving exchange, it is discarded.
- ii) If a circuit group reset acknowledgement message is received which is not a correct response to a sent circuit group reset message, it is discarded.
- iii) If a circuit group reset message is received requesting reset of circuits that are not controlled by the ISDN User Part, or a circuit group reset acknowledgement message that contains circuit identification codes that are not controlled by the ISDN User Part, the message is discarded.

### **2.9.4 Failure in the blocking/unblocking sequence**

An exchange will repeat the blocking (unblocking) message or the circuit group blocking (unblocking) message on failure to receive the appropriate acknowledgement in response to one of these messages before 15-60 seconds (T12, T14, T18, T20 appropriately). (See 2.8.2).

If the appropriate acknowledgement is not received within a period of 5-15 minutes (T13, T15, T19, T21 appropriately) after sending the initial blocking (unblocking) message or group blocking (unblocking) message, the maintenance system should be alerted, the repetition of the blocking (unblocking) message or circuit group blocking (unblocking) message should be continued at one minute intervals until maintenance intervention occurs and the circuit(s) taken out of (returned to) service as appropriate.

### **2.9.5 Receipt of unreasonable signalling information messages**

The message transfer part of the signalling system will avoid mis-sequencing, or double delivery, of messages with a high reliability (see 2/Q.706). However, undetected errors at the signalling link level and exchange malfunctions may produce signalling information messages that are either ambiguous or inappropriate.

Unreasonable or unexpected signalling information may also be received at an exchange due to differing levels of signalling protocol enhancements at different exchanges within a network: an exchange using a more enhanced version of the protocol may send information to a less enhanced exchange which is outside the protocol definition supported at that exchange.

The degree of applicability of the procedures below at exchanges where there are differences between the capabilities of the incoming and outgoing signalling systems, e.g. between the national and international sides of a gateway, is for further study.

The procedures listed below do not include the procedures for the blocking, circuit group blocking and the circuit group reset, these are covered in 2.8.2.3 and 2.9.3.3 respectively.

The following are considered message format errors :

- a) The message length is less than the number of octets required for the fixed mandatory part, the mandatory variable pointers and the start of optional parameters pointer.
- b) A mandatory variable or start of optional parameter's pointer points beyond the message length.
- c) A mandatory variable or optional parameter's length indicator causes the overall message length to be exceeded.

When a message format error is detected, the message shall be discarded.

NOTE – A format error can only be detected when the message is recognized.

For the purposes of format error detection, the message length may be interpreted as either,

- i) received message length; or
- ii) maximum message length (272 octets).

Interpretation i) is preferred as it will detect errors which may not be found by interpretation ii). However, it is not contained in the MTP Recommendations that the received message length is passed to its users by the MTP.

#### **2.9.5.1 Handling of unexpected messages**

An unexpected message is one which contains a message type code that is within the set supported at this exchange, but is not expected to be received in the current state of the call.

In order to resolve possible ambiguities in the state of a circuit when unexpected messages are received, the following procedures will apply:

- a) if a release message is received relating to an idle circuit, it will be acknowledged with a release complete message;
- b) if a release complete message is received relating to an idle circuit, it will be discarded;
- c) if a release complete message is received relating to a busy circuit for which a release message has not been sent, the circuit will be released and a release message will be sent;
- d) if a release complete message is received identifying one of the busy circuits being used by a multirate connection type call for which a release message has not been sent, the call will be cleared, all circuits made idle and a release message sent indicating the lowest circuit identification code of the multiple 64 kbit/s circuits used by the call;
- e) if other unexpected signalling messages are received, the following actions will be undertaken:
  - if the circuit is idle, the reset circuit message is sent;
  - if the circuit is seized by a call, after receipt of a backward message required for the call set-up, the unexpected signalling message is discarded, except in certain cases, see 2.9.1;
  - if the circuit is seized by a call, before receipt of a backward message required for the call set-up, the reset circuit message is sent (or, in the case of a multirate connection type call, a circuit group reset message or multiple reset circuit messages are sent). If the circuit is seized by an incoming call, any interconnected circuits will be released. If the circuit is seized by an outgoing call, an automatic repeat attempt is provided on another circuit.

#### **2.9.5.2 General requirements on receipt of unrecognized signalling information messages and parameters**

It may happen that an exchange receives unrecognized signalling information, i.e. messages, parameter types or parameter values. This can typically be caused by the upgrading of the signalling system used by other exchanges in the network. In these cases, the following compatibility procedures are invoked to ensure the predictable network behaviour.

The procedures to be used on receipt of unrecognized information make use of:

- a) compatibility information received in the same message as the unrecognized information;
- b) the confusion message;
- c) the release message;
- d) the release complete message;
- e) the facility reject message; or
- f) the cause indicators parameter; the following cause values are used:
  - (97) message type non-existent or not implemented – discarded;
  - (99) parameter non-existent or not implemented – discarded;



- (103) parameter non-existent or not implemented – passed on (see Note);
- (110) message with unrecognized parameter – discarded.

NOTE – This cause value may be received from a *Blue Book* (1988) ISDN User Part, but will not be generated from a (1992) ISDN User Part.

For all the above cause values a diagnostic field is included containing, dependant on the cause value either, the unrecognized parameter name(s), the message type code, or the message type code and the unrecognized parameter name(s).

The procedures are based on the following assumptions:

- i) Signalling for a facility completely provided between the originating and destination local exchanges will utilize one of the end-to-end methods defined in Recommendation Q.730, i.e. such facilities do not have to be supported by transit exchanges.
- ii) The forward compatibility information contains different instructions for different exchanges. There are two types of exchanges, type A and type B exchanges. The classification of type A and B exchanges to the functional type an exchange may perform is listed below. It is determined on a per call basis.

*Type A:*

- Originating exchange, i.e. the exchange in which the call is generated from a national public network point of view.
- Destination exchange, i.e. the exchange to which the call is destined from a national public network point of view.
- Interworking exchange, i.e. the exchange in which interworking is performed between ISDN User Part and other user parts or signalling systems.
- Incoming or outgoing international exchange (see Note).

NOTE – In an incoming or outgoing international exchange, the instruction to pass on a message or a parameter does not preclude the normal policing functions of these exchanges. It is recommended that an exchange interconnecting two national networks should behave as an incoming or outgoing international exchange.

*Type B:*

- National or international transit exchange, i.e. an exchange that acts just as a transit node.
- iii) Since type A and type B exchanges can be both national and international exchanges, the compatibility mechanism is applicable to the national and international network.
  - iv) As a minimum, all implementations must recognize all messages specified in Table 3/Q.761 and all parameters specified in Table 4/Q.761.
  - v) If an exchange receives a confusion, a release, a release complete or facility reject message indicating an unrecognized message or parameter received, it assumes interaction with an exchange at a different functional level. See 2.9.5.3 for more details on this.
  - vi) All unrecognized messages that can be received only contain parameters coded as optional parameters, no “new” messages will contain mandatory fixed or mandatory variable parameters.

If messages are received without compatibility information and are not recognized, they are discarded and the confusion message is sent.

When an unrecognized parameter or message is received, the exchange should find some corresponding instructions contained in the parameter compatibility information or message compatibility information parameters respectively. The parameter compatibility information parameter may contain compatibility instructions for more than one parameter. The message compatibility information parameter contains the instructions specific for the handling of the complete message.

If the exchange does not find instructions in an appropriate compatibility parameter or if the compatibility parameter is not found in the message, the actions default to a basic action. Details of this are found in 2.9.5.3.

The instruction indicators are a set of boolean indicators. The following general rules apply to the examination of these instruction indicators:

- i) Depending on the role of the exchange in the call, i.e. type A or type B, and the settings of the indicators only a subset of the indicators are examined, some being ignored.

Only type B exchanges examine the “Transit at Intermediate Exchange indicator”. If it is set to “Transit Interpretation”, the other indicators are ignored. If it is set to “End Node Interpretation”, the according actions are performed.

Type A exchanges always interpret the remaining indicators, i.e. all indicators except the “Transit at Intermediate Exchange indicator”.

Consequently, “End Node Interpretation” means that all kinds of exchanges, i.e. type A and type B, have to interpret the instruction indicators.

- ii) Instruction indicators marked as “spare” are not examined. They may be used by future versions of the ISDN User Part; in this case the future version of the ISDN User Part will set the currently defined instruction indicators to a reasonable value for the current version. This rule ensures that more types of instructions can be defined in the future without creating a backward compatibility problem.
- iii) An exchange must decide what exchange type it is for the call before performing compatibility actions.
- iv) At a type B exchange the unrecognized information should be passed on unchanged, if the “Transit at Intermediate exchange indicator” is set to “Transit Interpretation”.
- v) At a type A exchange the “Transit at Intermediate Exchange indicator” is not applicable.
- vi) At a type B exchange that has not been instructed to pass on the unrecognized information, if the “Release Call indicator” is set to “Release Call”, the call is released.

At a type A exchange, the call is released if the “Release Call indicator” is set to “Release Call”.

- vii) At a type B exchange that has not been instructed to pass on the unrecognized information or at a type A exchange, in any case the following is applicable if the “Release Call indicator” is set to “Do Not Release Call”:
  - if the “Discard Message indicator”, or the “Discard Parameter indicator” is set to “Discard Message/Discard Parameter”, the message or parameter is discarded, as instructed,
  - and then, if the “Send Notification indicator” is set to “Send Notification”, a confusion message is sent towards the exchange that sent the unrecognized information.
- viii) For the case of an unrecognized parameter it is possible for the instruction to require that either the unrecognized parameter or the whole message is discarded. This provides for the case where the sending exchange determines that it is not acceptable for the message to continue being processed without this parameter.
- ix) In case a parameter is included more than once in the same message, the instruction indicator of the parameter compatibility information parameter is set according to the most stringent combination of the possible codings (i.e. the coding “1” of a bit in the instruction indicator is dominant).
- x) In case a message is used for more than one procedure simultaneously and the codings of the instruction indicator of the message compatibility information parameter described in the corresponding texts are different, the instruction indicator is set according to the most stringent combination of the possible codings (i.e. the coding “1” of a bit in the instruction indicator is dominant).
- xi) At a type A exchange where “pass on” has been specified for a message or parameter and “pass on” is not possible, then the “pass on not possible indicator” and “send notification indicator” are checked.
- xii) The following Tables 1 and 2 clarify the handling of the received compatibility information.

### **2.9.5.3 Procedures for the handling of the unrecognized messages or parameters**

A confusion message must not be sent in response to a received confusion, facility reject, release or release complete message. Any unrecognized parameters received in a confusion, facility reject or release complete message are discarded. Any unrecognized mandatory parameter value received in a confusion or facility reject message will result in the message being discarded.

TABLE 1/Q.764

**On receipt of message compatibility information parameter**

| Instruction indicator |   |   | Required action   |
|-----------------------|---|---|---|
| B                     | C | D |   |
| 0                     | 0 | 0 | Pass on message (Note 2)                                    |
| 0                     | 0 | 1 | Discard message   |
| 0                     | 1 | 0 | Pass on message (don't send a notification) (Notes 2 and 3) |
| 0                     | 1 | 1 | Discard message and send notification                       |
| 1                     | X | X | Release call  |

Bit B Release call indicator  
0 Do not release call  
1 Release call

Bit C Send notification indicator  
0 Do not send notification  
1 Send notification

Bit D Discard message indicator  
0 Do not discard message (pass on)  
1 Discard message

NOTES

1 «X» = don't care.

2 Applicable for type B exchanges and incoming or outgoing international exchanges using an ISUP'92 or a later version. Other exchanges (e.g. originating, terminating, interworking) ignore bit D.

3 In case of passing on a message, no notification is sent, bit C is ignored.

**2.9.5.3.1 Unrecognized messages**1) *Actions at type A exchanges*

## a) Compatibility parameter received

Depending on the instructions received in the "Message Compatibility Information parameter", a type A exchange receiving an unrecognized message will either:

- transfer the message transparently (Note);
- discard the message;
- discard the message and send confusion; or
- release the call.

NOTE – The transparent passing of a message is only applicable when the signalling is ISUP'92 or a later version.

A release and a confusion message shall include the cause value 97, "message type non-existent or not implemented – discarded", followed by a diagnostic field containing the message type code.

## b) Compatibility parameter not received

If an unrecognized message is received without "Message Compatibility Information parameter" at an exchange, the message is discarded and a confusion message is returned. A confusion message shall include the cause value 97, "message type non-existent or not implemented – discarded", followed by a diagnostic field containing the message type code.

NOTE – All messages not included in Table 3/Q.761 may be regarded as unrecognized. As a minimum all implementations must recognize all messages specified in Table 3/Q.761.

2) *Actions at type B exchange*

a) Compatibility parameter received

Depending on the instructions received in the “Message Compatibility Information parameter”, a type B exchange receiving an unrecognized message will either:

- transfer the message transparently;
- discard the message;
- discard the message and send confusion; or
- release the call.

A confusion message shall include the cause value 97, “message type non-existent or not implemented – discarded”, followed by a diagnostic field containing the message type code.

A release message shall include the cause value 97, “message type non-existent or not implemented – discarded”, followed by a diagnostic field containing the message type code.

NOTE – All messages not included in Table 3/Q.761 may be regarded as unrecognized. As a minimum all implementations must recognize all messages specified in Table 3/Q.761.

b) Compatibility parameter not received

If an unrecognized message is received without “Message Compatibility Information parameter” at an exchange, the message is discarded and a confusion message is returned. A confusion message shall include the cause value 97, “message type non-existent or not implemented – discarded”, followed by a diagnostic field containing the message type code.

TABLE 2/Q.764

**On receipt of parameter compatibility information parameter**

| Instruction indicator |   |                                    |   | Required action   |
|-----------------------|---|------------------------------------|---|---|
| B                     | C   | D                                  | E |   |
| 0                     | 0   | 0                                  | 0 | Pass on parameter (Note 2)                                    |
| 0                     | 0   | 0                                  | 1 | Discard parameter   |
| 0                     | 0   | 1                                  | 0 | Discard message   |
| 0                     | 0   | 1                                  | 1 | Discard message   |
| 0                     | 1   | 0                                  | 0 | Pass on parameter (don't send a notification) (Notes 2 and 3) |
| 0                     | 1   | 0                                  | 1 | Discard parameter and send notification                       |
| 0                     | 1   | 1                                  | 0 | Discard message and send notification                         |
| 0                     | 1   | 1                                  | 1 | Discard message and send notification                         |
| 1                     | X   | X                                  | X | Release call  |
| Bit                   | B   | Release call indicator             |   |   |
|                       | 0   | Do not release call                |   |   |
|                       | 1   | Release call                       |   |   |
| Bit                   | C   | Send notification indicator        |   |   |
|                       | 0   | Do not send notification           |   |   |
|                       | 1   | Send notification                  |   |   |
| Bit                   | D   | Discard message indicator          |   |   |
|                       | 0   | Do not discard message (pass on)   |   |   |
|                       | 1   | Discard message                    |   |   |
| Bit                   | E   | Discard parameter indicator        |   |   |
|                       | 0   | Do not discard parameter (pass on) |   |   |
|                       | 1   | Discard parameter                  |   |   |
| NOTES                 |   |                                    |   |   |
| 1                     | «X» = don't care.   |                                    |   |   |
| 2                     | Applicable for type B exchanges and incoming or outgoing international exchanges using an ISUP'92 or a later version. Other exchanges (e.g. originating, terminating, interworking) ignore bit D. |                                    |   |   |
| 3                     | In case of passing on a message, no notification is sent, bit C is ignored.   |                                    |   |   |

### 2.9.5.3.2 Unrecognized parameters

Receipt of unrecognized parameters can only refer to optional parameters, since mandatory parameters will always be recognized by their location in a message.

The minimum set of recognized parameters is contained in Table 4/Q.761. Unexpected parameters (a parameter in the “wrong” message) are handled like unrecognized parameters.

i) *Actions at type A exchange*

a) Compatibility parameter received

Depending on the instructions received in the “Parameter Compatibility Information parameter”, a type A exchange receiving an unrecognized parameter will either:

- transfer the parameter transparently;
- discard the parameter;
- discard the message;
- discard the parameter and send confusion;
- discard the message and send confusion; or
- release the call.

NOTE – The transparent passing of a parameter is only applicable when the signalling is ISUP'92 or a later version.

A confusion message shall include the cause value 99, “parameter non-existent or not implemented – discarded” followed by a diagnostic field containing the parameter name, or 110, “message with unrecognized parameter – discarded”, followed by a diagnostic field containing the message name and the name of the first detected unrecognized parameter which caused the message to be discarded. A confusion message may refer to multiple unrecognized parameters.

A release message shall include the cause value 99, “parameter non-existent or not implemented – discarded”, followed by a diagnostic field containing the parameter name.

If an unrecognized parameter is received in a facility request message, the parameter is handled like unrecognized parameters in other messages.

If a release message is received containing an unrecognized parameter, depending on the instructions received in the compatibility information parameter, a type A exchange will either:

- discard the parameter; or
- discard the parameter and send a cause 99, “parameter non-existent or not implemented – discarded”, in the release complete message.

b) Compatibility parameter not received

If an exchange receives and detects an unrecognized parameter without a “Parameter Compatibility Information parameter”, the actions taken will be dependent on whether the unrecognized parameter is passed on or discarded. If the unrecognized parameter is discarded, a confusion message is sent to the exchange from which the unrecognized parameter was received. The confusion message contains the cause value 99, “parameter non-existent or not implemented – discarded”, followed by a diagnostic field containing the parameter name. A confusion message may refer to multiple unrecognized parameters. If the unrecognized parameter is passed on unmodified, no subsequent actions are necessary.

If a facility request message is received with unrecognized parameters, the message is discarded and a facility reject message is returned including the cause value 99, “parameter non-existent or not implemented – discarded”, followed by the parameter name code in the diagnostic field.

If a release message containing an unrecognized parameter is received at a type A exchange, a release complete message is returned including the cause value 99, “parameter non-existent or not implemented – discarded”.

ii) *Actions at type B exchange*

a) Compatibility parameter received

Depending on the instructions received in the “Parameter Compatibility Information parameter”, a type B exchange receiving an unrecognized parameter will either:

- transfer the parameter transparently;
- discard the parameter;
- discard the message;
- discard the parameter and send confusion;
- discard the message and send confusion; or
- release the call.

A confusion message shall include the cause value 99, “parameter non-existent or not implemented – discarded”, followed by a diagnostic field containing the parameter name, or 110, “message with unrecognized parameter – discarded”, followed by a diagnostic field containing the message name and the name of the first detected unrecognized parameter which caused the message to be discarded. A confusion message may refer to multiple unrecognized parameters. If the unrecognized parameter is passed on unmodified, no subsequent actions are necessary.

A release message shall include the cause value 99, “parameter non-existent or not implemented – discarded”, followed by a diagnostic field containing the parameter name.

If an unrecognized parameter is received in a facility request message, the parameter is handled like unrecognized parameters in other messages.

Depending on the instructions received in the “Parameter Compatibility Information parameter”, an exchange receiving an unrecognized parameter in a release message will either:

- transfer the parameter transparently;
- discard the parameter; or
- discard the parameter and send a cause 99, “parameter non-existent or not implemented – discarded”, in the release complete message.

b) Compatibility parameter not received

If an exchange receives and detects an unrecognized parameter without a “Parameter Compatibility Information parameter”, the actions taken will be dependent on whether the unrecognized parameter is passed on or discarded. If the unrecognized parameter is discarded, a confusion message is sent to the exchange from which the unrecognized parameter was received. The confusion message contains the cause value 99, “parameter non-existent or not implemented – discarded”, followed by a diagnostic field containing the parameter name. A confusion message may refer to multiple unrecognized parameters. If the unrecognized parameter is passed on unmodified, no subsequent actions are necessary.

If a facility request message is received with unrecognized parameters, the message is discarded and a facility reject message is returned including the cause value 99, “parameter non-existent or not implemented – discarded”, followed by the parameter name code in the diagnostic field.

If a release message containing an unrecognized parameter that cannot be passed on is received at a type B exchange, a release complete message is returned including the cause value 99, “parameter non-existent or not implemented – discarded”.

### 2.9.5.3.3 Unrecognized parameter values

Any parameter values marked as “spare”, “reserved” or “national use” in Recommendation Q.763 may be regarded as unrecognized.

If an exchange receives and detects a recognized parameter, but the contents are unrecognized, then the actions are as defined as below:

a) *Unrecognized mandatory parameter values*

Unrecognized mandatory parameter values can only occur for parameters defined in messages of the *Blue Book* (1988) ISDN User Part. This ISDN User Part does not contain any mandatory parameters in new messages.

If an exchange receives and detects an unrecognized mandatory parameter value, the actions taken in the different types of exchanges will be dependent on the Tables A.2/Q.763 and A.3/Q.763.

If a facility request message is received with unrecognized mandatory parameter value(s) and without parameter compatibility information, the actions to be taken are described in the above mentioned tables, i.e. the message is discarded and a facility reject message is returned including the cause value 99, "parameter non-existent or not implemented – discarded", followed by the parameter name code in the diagnostic field indicating the first detected unrecognized parameter.

If a release message is received with unrecognized mandatory parameter value(s) and without parameter compatibility information, the actions to be taken are described in the above mentioned tables.

b) *Unrecognized optional parameter values*

The procedures as stated for unrecognized parameters apply. There is no specific compatibility information field for each parameter value. For all parameter values contained in a parameter, the compatibility information of the parameter applies.

If unrecognized parameter values are received and detected in optional parameters which are already defined in *Blue Book* Recommendation Q.763, the actions taken will be dependent on the tables contained in Recommendation Q.763.

## **2.9.5.4 Procedures for the handling of responses indicating unrecognized information has been sent**

### **2.9.5.4.1 Type A exchanges**

Action taken on receipt of these messages at an originating or terminating exchange will depend on the call state and the affected service.

The definition of any procedure that is outside the basic call set-up protocol, as defined in this Recommendation, should include procedures for handling responses that indicate that another exchange has received, but not recognized, information belonging to that procedure. The procedure receiving this response should take the appropriate actions.

The default action taken on receipt of a confusion message is to discard the message without disrupting normal call processing.

### **2.9.5.4.2 Type B exchanges**

i) *Confusion (message type non-existent or not implemented – discarded)*

An exchange receiving confusion (message type non-existent or not implemented – discarded) has to determine the appropriate subsequent actions as described for type A exchanges in the above subclause.

ii) *Confusion (parameter non-existent or not implemented – discarded, or passed on)*

The actions taken at a type B exchange, on receipt of a confusion message will depend on whether the exchange has the functionality to generate the parameter identified in the diagnostic field :

- a) If the exchange does not have the functionality to generate the parameter, the decision on what action should be taken is deferred to an exchange that does contain this functionality. This is achieved by passing the confusion message transparently through the type B exchange.
- b) If this exchange does have the functionality to generate the parameter, the procedural element that created or modified the information should determine any subsequent actions, as described for type A exchanges above.

iii) *Facility reject*

If a type B exchange does not have the capability to take action on receipt of facility reject, it should pass the message transparently to the preceding or succeeding exchange.

iv) *Release and release complete*

Action taken on receipt of a release or a release complete message with cause indicating unrecognized information is as for the normal procedures for these messages.

The above actions are summarized in Table 3.

TABLE 3/Q.764

**a) Handling of responses indicating unrecognized information has been sent**

|                  | Exchange has the functionality to generate the information |                        |                   |                   |
|------------------|--|------------------------|-------------------|-------------------|
|                  | Cause  |                        |                   |                   |
| Message          | Parameter discarded  | Parameter passed on    | Message discarded | Message passed on |
| Confusion        | (procedure dependent action)                               |                        |                   |                   |
| Facility reject  | Normal procedures  | Procedure depend. act. | Not applicable    | Not applicable    |
| Release          | Normal procedures  | Not applicable         | Not applicable    | Not applicable    |
| Release complete | Normal procedures  | Normal procedures      | Not applicable    | Not applicable    |

**b) Handling of responses indicating unrecognized information has been sent**

|                  | Exchange does not have the functionality to generate the information |                     |                   |                   |
|------------------|--|---------------------|-------------------|-------------------|
|                  | Cause  |                     |                   |                   |
| Message          | Parameter discarded  | Parameter passed on | Message discarded | Message passed on |
| Confusion        | Defer action (transit confusion)                                     |                     |                   |                   |
| Facility reject  | Defer action (transit)   |                     |                   |                   |
| Release          | Normal procedures  | Not applicable      | Not applicable    | Not applicable    |
| Release complete | Normal procedures  | Normal procedures   | Not applicable    | Not applicable    |

**2.9.5.5 Procedures for handling unreasonable information**

If a message is received that

- a) is of valid type, i.e. it is not unexpected or unrecognized as described in 2.9.5.1 and 2.9.5.3; and
- b) it contains parameters of recognized type and value, i.e. the procedures in 2.9.5.3 do not apply,

it is still possible that the contents of the message is unreasonable. This can be as a result of conflicting information within the message. The following example of this is identified:

- The Protocol Control Indicators, (in either the Forward or Backward call indicators) can contain conflicting information. e.g. End-to-End Method Indicator set to “no method available”, but the SCCP Method Indicator set to indicate that an SCCP method is available. This situation should be handled by assuming the lower network capability for the affected parameter.

**2.9.6 Failure to receive a “release complete” message – Timer T1 and T5**

If a release complete message is not received in response to a release message before expiry of timer (T1), the exchange will retransmit the release message.



On transmitting the initial release message, a 5-15 minute timer (T5) is started. If no release complete message is received on the expiry of this timer (T5), the exchange shall:

- i) send a reset circuit message;
- ii) alert the maintenance system;
- iii) remove the circuit from service;
- iv) continue the sending of the reset circuit message at 5-15 minute intervals until maintenance action occurs.

### **2.9.7 Failure to receive a response to an information request message (national use)**

If a response is not received in response to an information request message before timer T33 expires, the exchange will release the connection and the maintenance system may be informed.

### **2.9.8 Other failure conditions**

#### **2.9.8.1 Inability to release in response to a release message**

If an exchange is unable to return the circuit to the idle condition in response to a release message, it should immediately remove the circuit from service, alert the maintenance system and send the blocking message.

Upon receipt of the blocking acknowledgement message, the release complete message is sent in acknowledgement of the release message.

#### **2.9.8.2 Call-failure**

The call-failure indication (cause value 31) is sent in a release message (see 2.2) whenever a call attempt fails and other specific cause values do not apply. Reception of the release message at any Signalling System No. 7 exchange will cause the release message to be sent to preceding exchanges. If the signalling does not permit the release message to be sent, the appropriate signal, tone or announcement is sent to preceding exchanges.

#### **2.9.8.3 Abnormal release conditions**

If the conditions for normal release as covered in 2.3 are not fulfilled, release will take place under the following conditions:

a) *Outgoing international or national controlling exchange*

The exchange shall:

- release all equipment and the connection on failure to meet the conditions for normal release of address and routing information before 20-30 seconds after sending the latest address message;
- release all equipment and release the connection on failure to receive an answer message within time T9 specified in Recommendation Q.118 after the receipt of the address complete message.

b) *Incoming international exchange*

An incoming international exchange shall release all equipment and the connection into the national network and send back a release message in the following cases:

- on failure to receive a continuity message if applicable before 10-15 seconds (T8) after receipt of the initial address message; or
- on failure to receive a backward signal from a national network (where expected) before 20-30 seconds (T7) after receipt of the latest address message; or
- on receipt of a release message after an address complete message has been generated; or
- on failure to receive an address message before 15-20 seconds (T35) after receipt of the latest address message and before the minimum or fixed number of digits have been received.

The procedures for the release message are detailed in 2.2.2.

c) *Transit exchange*

The exchange shall release all equipment and the connection and send back the release message in the following cases:

- on failure to receive a continuity message if applicable before 10-15 seconds after receipt of the initial address message; or
- on failure to meet the conditions for normal release as covered in 2.3 before 20-30 seconds after sending the latest address message; or
- on failure to receive an address message before 15-20 seconds (T35) after receipt of the latest address message and before the minimum or fixed number of digits have been received.

The procedures for the release message are detailed in 2.2.2.

## **2.9.9 Temporary trunk blocking (TTB) (national use)**

TTB is essentially a means of blocking circuits on a route, for a predetermined period, to reduce traffic to an exchange which has invoked load control. Circuits are removed from service on a per circuit basis under delay time out conditions applied by the unaffected exchange, on receipt of an overload message.

### **2.9.9.1 Procedures**

a) *Non priority call set-up to an exchange subject to load control*

i) *Actions at originating exchange*

In an originating exchange, calls originating from non-priority class lines will not set the calling party category parameter field to “subscriber with priority” in the outgoing initial address message.

ii) *Actions at an intermediate or terminating exchange*

When an initial address message is received by an exchange which is subject to load control and the calling party category parameter does not indicate a priority call, the initial address message is not processed and an overload message is returned to the preceding exchange.

iii) *Actions on receipt of the overload message*

At an originating, or intermediate exchange receipt of the overload message shall cause the following actions:

- A timer (T3) is started, value 2 minutes. On expiry of the timer the release procedure shall be initiated for the circuit concerned. During the overload time-out period the circuit concerned is not available for traffic from the affected node to the unaffected node.
- The call attempt will be continued on an alternative route if available. If not the call will be released in the backward direction with cause value 42 (switching equipment congestion).

b) *Priority call set-up to an exchange subject to load control*

i) *Actions at originating exchange*

In an originating exchange, calls originating from priority class lines will set the calling party category parameter field to “subscriber with priority” in the outgoing initial address message.

ii) *Actions at intermediate or terminating exchange*

At an intermediate or terminating exchange where load control has been invoked, the priority call will override the load control and the call will continue in its attempt to be set up.

## **2.10 ISDN User Part signalling congestion control**

### **2.10.1 General**

On receipt of congestion indication [contained in MTP status primitives (see also 11.2.3/Q.704)] the ISDN User Part should reduce traffic load (e.g. call attempts) into the affected destination point code in several steps.

### **2.10.2 Procedures**

When the first congestion indication is received by the ISDN User Part, the traffic load into the affected destination point code is reduced by one step. At the same time two timers T29 and T30 are started. During T29 all received congestion indications for the same destination point code are ignored in order not to reduce traffic too rapidly. Reception of a congestion indication after the expiry of T29, but still during T30, will decrease the traffic load by one more step and restart T29 and T30. This step wise reduction of the ISDN User Part signalling traffic is continued until maximum reduction is obtained by arriving at the last step. If T30 expires (i.e. no congestion indications having been received during the T30 period) traffic will be increased by one step and T30 will be restarted unless full traffic load has been resumed.

Timers T29 and T30 have the following values:

T29 = 300-600 ms;

T30 = 5-10 s.

The number of steps of traffic reduction and the type and/or amount of increase/decrease of traffic load at the various steps are considered to be an implementation matter.

## **2.11 Automatic congestion control**

Automatic congestion control (ACC) is used when an exchange is in an overload condition (see also Recommendation Q.542). Two levels of congestion are distinguished, a less severe congestion threshold (congestion level 1) and a more severe congestion threshold (congestion level 2).

If either of the two congestion thresholds are reached, an automatic congestion level parameter is added to all release messages generated by the exchange. This parameter indicates the level of congestion (congestion level 1 or 2) to the adjacent exchanges. The adjacent exchanges, when receiving a release message containing an automatic congestion level parameter should reduce their traffic to the overload affected exchange.

If the overloaded exchange returns to a normal traffic load it will cease including automatic congestion level parameters in release messages.

The adjacent exchanges then, after a predetermined time, automatically return to their normal status.

### **2.11.1 Receipt of a release message containing an automatic congestion level parameter**

When an exchange receives a release message containing an automatic congestion level parameter, the ISDN User Part should pass the appropriate information to the signalling system independent network management/overload control function within the exchange. This information consists of the received congestion level information and the circuit identification to which the release message applies.

If the automatic congestion level procedure is not implemented, the automatic congestion level parameter is not acted upon and discarded as normal.

Automatic congestion level actions are applicable only at exchanges adjacent to the congested exchange. Therefore, an exchange that receives a release message containing an automatic congestion level parameter should discard that parameter after notifying the network management/overload control function.

### **2.11.2 Actions taken during overload**

Whenever an exchange is in an overload state (congestion level 1 or 2), the signalling system independent network management/overload control function will direct the ISDN User Part to include an automatic congestion level parameter in every release message transmitted by the exchange.

The network management/overload control function will indicate which congestion level (1 or 2) to code in the automatic congestion level parameter.

When the overload condition has ended the network management/overload control function will direct the ISDN User Part to cease including automatic congestion level parameters in the transmitted release messages.

### **2.12 Unequipped circuit identification code message (national use)**

An unequipped circuit identification code message is sent by an exchange in response to either the reception of an initial address message, a continuity check request message, a circuit supervision message, or a circuit group supervision message on which it is unable to act as a consequence of its inability to perform a circuit identification code translation.

If an unequipped circuit identification code message is received for an Signalling System No. 7 circuit which has been seized and an initial address message transmitted, the receiving exchange shall:

- 1) remove the indicated circuit from the service and report the circuit to the maintenance system for maintenance action;
- 2) re-attempt the call on another circuit providing the rejected attempt was a first attempt. If the rejected attempt was a second attempt, either a release message should be returned (if the incoming circuit is an Signalling System No. 7) or a recorded announcement connected (if the incoming circuit is conventional).

If an unequipped circuit identification code message is received in response to the transmission of a circuit supervision message, or a continuity check request message, the circuit should be removed from the service and the circuit reported to the maintenance system for maintenance action.

An exchange receiving a circuit group supervision message whose circuit identification code in the routing label is unequipped, should respond with a unequipped circuit identification code message for the circuit in the label. This in effect is the acknowledgement to the initial message. An exchange receiving a circuit group message where the circuit identification code in the routing label is equipped but one or more of the indicated circuits by the range field is unequipped merely responds in the manner that it would have if the circuit were equipped. The unequipped state of the circuit(s) will be recovered when an initial address message, a continuity check request message, or circuit query message is received for the affected circuit(s).

An exchange receiving an unequipped circuit identification code message after having transmitted a circuit group supervision message removes the indicated circuit from service, assumes the regular acknowledgement message will not be received and treats the other circuits as though the responding exchange had not taken the action on the affected circuits indicated in the initial message.

### **2.13 ISDN User Part availability control**

#### **2.13.1 General**

On receipt of a MTP-STATUS primitive with the cause "user part unavailability – inaccessible remote user", the ISDN User Part should mark the concerned user part unavailable and start the availability test procedure.

On receipt of a MTP-STATUS primitive with the cause "user part unavailability – unequipped remote user", the ISDN User Part should inform the management system.

### **2.13.2 Procedures**

When an MTP-STATUS primitive with the cause “user part unavailability – inaccessible remote user” is received, the network management/overload control function should be informed.

The user part shall send a user part test message (using a circuit identification code that is equipped in both switches) to the remote user and starts timer T4 which supervises the receipt of an answer to the user part test message.

As a reaction to the user part test message, the remote ISDN User Part sends the user part available message if it is available again.

If the user part test message is not recognized by the remote user part, a confusion message with cause 97 (message type non-existent or not implemented – discarded) is sent as a response.

All MTP-STATUS primitives with the cause “user part availability – inaccessible remote user” received while timer T4 is running are ignored.

On receipt of a user part available message or any other message timer T4 is stopped, the user part is marked available again and traffic is restarted.

On expiry of timer T4, the procedure is restarted.

When an MTP-STATUS primitive with the cause “user part unavailability – unequipped remote user” is received, the management system should be informed to restrict further traffic. The ISDN User Part should not initiate the availability test procedure for this case.

### **2.14 MTP Pause/Resume**

On the reception of a MTP pause primitive, the ISDN User Part takes the following action:

If the affected destination is not a destination (Signalling Point) known by the ISDN User Part (not connected by circuits to the exchange), no action takes place.

If the affected destination is a destination (Signalling Point) known by the ISDN User Part, all circuits are blocked for new calls.

Calls in progress need not be released even though signalling messages cannot be sent to the affected exchange. (While it may not be technically necessary to release calls in progress, network providers may choose to release such calls, perhaps after some time interval, if there is a concern about over charging due to the exchange’s inability to completely clear the call when either the calling or called party disconnects.)

On the reception of a MTP resume primitive, the ISDN User Part takes the following action:

If the affected destination is not a destination (Signalling Point) known by the ISDN User Part (not connected by circuits to the exchange), no action takes place.

If the affected destination is a destination (Signalling Point) known by the ISDN User Part, the circuits in the idle state can be used for calls immediately. Normal call release procedures that may have started during the period of signalling isolation continue and as such will ensure that affected circuits are returned to idle state.

### **2.15 Overlength messages**

If a sending exchange detects that a message to be sent exceeds the 272 octet MTP limit and the message is not able to be segmented or segmentation has already been applied, then the user-to-user information parameter (if present) should first be discarded followed by all unrecognized optional parameters to bring the message to within the 272 octet limit.

## Annex A

(This annex forms an integral part of this Recommendation)

TABLE A.1/Q.764

### Timers in the ISDN User Part (sheet 1 of 4)

| Symbol | Time-out value              | Cause for initiation   | Normal termination   | At expiry  | Reference                          |
|--------|-----------------------------|--|--|--|------------------------------------|
| T1     | 15-60 seconds               | When release message is sent   | At the receipt of release complete message   | Retransmit release message and start timer T1  | 2.9.6<br>2.2<br>2.3                |
| T2     | 3 minutes                   | When controlling exchange receives suspend (user) message  | At the receipt of resume (user) message at controlling exchange  | Initiate release procedure   | Q.733.4                            |
| T3     | 2 minutes                   | At receipt of overload message   | On expiry  | Initiate release procedure   | 2.9.9                              |
| T4     | 5-15 minutes                | At receipt of MTP-STATUS primitive with the cause "remote user unavailable"  | On expiry, or at receipt of user part available message (or any other)   | Send user part test message. Start T4  | 2.13.2                             |
| T5     | 5-15 minutes                | When initial release message is sent   | At receipt of release complete message   | Send reset circuit message, alert maintenance personnel and remove the circuit from service, stop T1, start T17. Procedure continues until maintenance intervention occurs | 2.9.6                              |
| T6     | Covered in Q.118            | When controlling exchange receives suspend (network)   | At the receipt of resume (network) message or release message  | Initiate release procedure   | 2.4.1<br>2.4.2<br>2.4.3            |
| T7     | 20-30 seconds               | When the latest address message is sent  | When the condition for normal release of address and routing information is met (receipt of ACM, CON messages) | Release all equipment and connection (Send release message)  | 2.1.1<br>2.1.2<br>2.1.4<br>2.9.8.3 |
| T8     | 10-15 seconds               | When an exchange receives initial address message requiring continuity check on this circuit or indicates that continuity check has been performed on a previous circuit | At receipt of continuity message   | Release all equipment and connection into the network (Send release message)   | 2.9.8.3                            |
| T9     | Interval specified in Q.118 | When national controlling or outgoing international exchange receives ACM  | At the receipt of answer   | Release connection send back release message   | 2.1.4<br>2.1.7<br>2.9.8.3          |

TABLE A.1/Q.764

**Timers in the ISDN User Part** (sheet 2 of 4)

| Symbol | Time-out value | Cause for initiation   | Normal termination                                  | At expiry  | Reference          |
|--------|----------------|--|---|--|--------------------|
| T10    | 4-6 seconds    | When last digit is received in interworking situations             | At the receipt of fresh information                 | Send address complete message  | 2.1.2.1<br>2.1.4.9 |
| T11    | 15-20 seconds  | When latest address message is received in interworking situations | When ACM is sent                                    | Send address complete message  | 2.1.4.9            |
| T12    | 15-60 seconds  | When blocking message is sent                                      | At receipt of blocking acknowledgement              | Retransmit blocking message and start T12  | 2.9.4              |
| T13    | 5-15 minutes   | When initial blocking message is sent                              | At receipt of blocking acknowledgement              | Transmit blocking message and alert maintenance personnel, start T13, stop T12. Procedure continues until maintenance intervention occurs      | 2.9.4              |
| T14    | 15-60 seconds  | When unblocking message is sent                                    | At receipt of unblocking acknowledgement            | Retransmit unblocking message and start T14  | 2.9.4              |
| T15    | 5-15 minutes   | When initial unblocking message is sent                            | At receipt of unblocking acknowledgement            | Retransmit unblocking message alert maintenance personnel, start T15 and stop T14. Procedure continues until maintenance intervention occurs   | 2.9.4              |
| T16    | 15-60 seconds  | When reset circuit message is sent not due to expiry of T5         | At the receipt of the acknowledgement (RLC message) | Retransmit reset circuit message and start T16   | 2.9.3.1            |
| T17    | 5-15 minutes   | When initial reset circuit message is sent                         | At the receipt of the acknowledgement               | Alert maintenance personnel, retransmit reset circuit message, start T17, stop T16. Procedure continues until maintenance intervention occurs  | 2.9.3.1            |
| T18    | 15-60 seconds  | When group blocking message is sent                                | At receipt of group blocking acknowledgement        | Retransmit group blocking message and start T18  | 2.9.4              |
| T19    | 5-15 minutes   | When initial group blocking message is sent                        | At receipt of group blocking acknowledgement        | Retransmit group blocking message, alert maintenance personnel, start T19, stop T18. Procedure continues until maintenance intervention occurs | 2.9.4              |
| T20    | 15-60 seconds  | When group unblocking message is sent                              | At receipt of group unblocking acknowledgement      | Retransmit group unblocking message and start T20  | 2.9.4              |

TABLE A.1/Q.764

**Timers in the ISDN user part** (sheet 3 of 4)

| Symbol | Time-out value | Cause for initiation   | Normal termination                             | At expiry  | Reference |
|--------|----------------|--|--|--|-----------|
| T21    | 5-15 minutes   | When initial group unblocking message is sent                  | At receipt of group unblocking acknowledgement | Retransmit group unblocking message, alert maintenance personnel, start T21, stop T20. Procedure continues until maintenance intervention occurs   | 2.9.4     |
| T22    | 15-60 seconds  | When circuit group reset message is sent                       | At the receipt of the acknowledgement          | Retransmit circuit group reset message and start T22   | 2.9.3.2   |
| T23    | 5-15 minutes   | When initial circuit group reset message is sent               | At the receipt of the acknowledgement          | Alert maintenance personnel and start T23, retransmit circuit group reset message, stop T22. Procedure continues until maintenance intervention occurs   | 2.9.3.2   |
| T24    | < 2 seconds    | When check tone is sent  | At the receipt of backward check tone          | Send continuity message with failure indication and:<br>a) start T25 if continuity check was asked in IAM and make automatic repeat attempt; or<br>b) start T26 if continuity check was asked in CCR | Q.724     |
| T25    | 1-10 seconds   | When initial continuity check failure is detected              | –  | Send CCR message and repeat continuity check   | Q.724     |
| T26    | 1-3 minutes    | When second or subsequent continuity check failure is detected | –  | Send CCR message and repeat continuity check   | Q.724     |
| T27    | 4 minutes      | When continuity check failure indication is received           | At receipt of continuity check request message | Send reset circuit message. Start T16 and T17  | 2.1.8     |
| T28    | 10 seconds     | When send CQM  | At receipt of CQR                              | Alert maintenance  | 2.9.3.2   |
| T29    | 300-600 ms     | Congestion indication received when T29 not running            | –  | New congestion indication will be taken into account   | 2.10.2    |
| T30    | 5-10 seconds   | Congestion indication received when T29 not running            | –  | Restore traffic by one step if not yet at full load and start T30  | 2.10.2    |



TABLE A.1/Q.764

**Timers in the ISDN User Part** (sheet 4 of 4)

| Symbol | Time-out value              | Cause for initiation  | Normal termination   | At expiry  | Reference                 |
|--------|-----------------------------|---|--|--|---------------------------|
| T31    | > 6 minutes                 | Release of ISDN User Part signalling connection based on CO SCCP  | On expiry  | Call reference reusable  | Q.730                     |
| T32    | 3-5 seconds                 | When response to request of end-to-end connection establishment is sent                                     | At receipt of first end-to-end message from the remote end   | End-to-end message allowed to be sent                                | Q.730                     |
| T33    | 12-15 seconds               | When send INR   | On receipt of INF  | Release call, alert maintenance personnel                            | 2.1.6.2<br>2.9.7<br>Q.730 |
| T34    | 2-4 seconds                 | When indication of a segmented message is received on an IAM, ACM, CPG, ANM or CON message                  | At receipt of a segmentation message   | Proceed with call  | 2.1.12                    |
| T35    | 15-20 seconds               | At receipt of the latest digit (< > ST) and before the minimum or fixed number of digits have been received | At receipt of ST or when the minimum or fixed number of digits have been received                  | Send release message (cause 28)                                      | 2.2.5<br>2.9.8.3          |
| T36    | 10-15 seconds               | When transit or incoming international exchange receives continuity check request message                   | At receipt of continuity or release message  | Release all equipment, send reset circuit message. Start T16 and T17 | 2.1.8                     |
| T37    | 2-4 seconds                 | When request for an echo control device is sent to another exchange   | On expiry or when an indication of a half echo control device being included/not included is known | Half echo control device is included or enabled                      | 2.7.3                     |
| T38    | Interval specified in Q.118 | When the incoming international exchange sends to the preceding exchange a suspend (network) message        | At receipt of resume (network) or release message  | Send release message (cause 102)                                     | 2.4.1<br>2.4.2<br>2.4.3   |
| T39    | Interval specified in Q.730 | When an MCID request is sent  | At receipt of an MCID response   | Call continues   | Q.731.7                   |

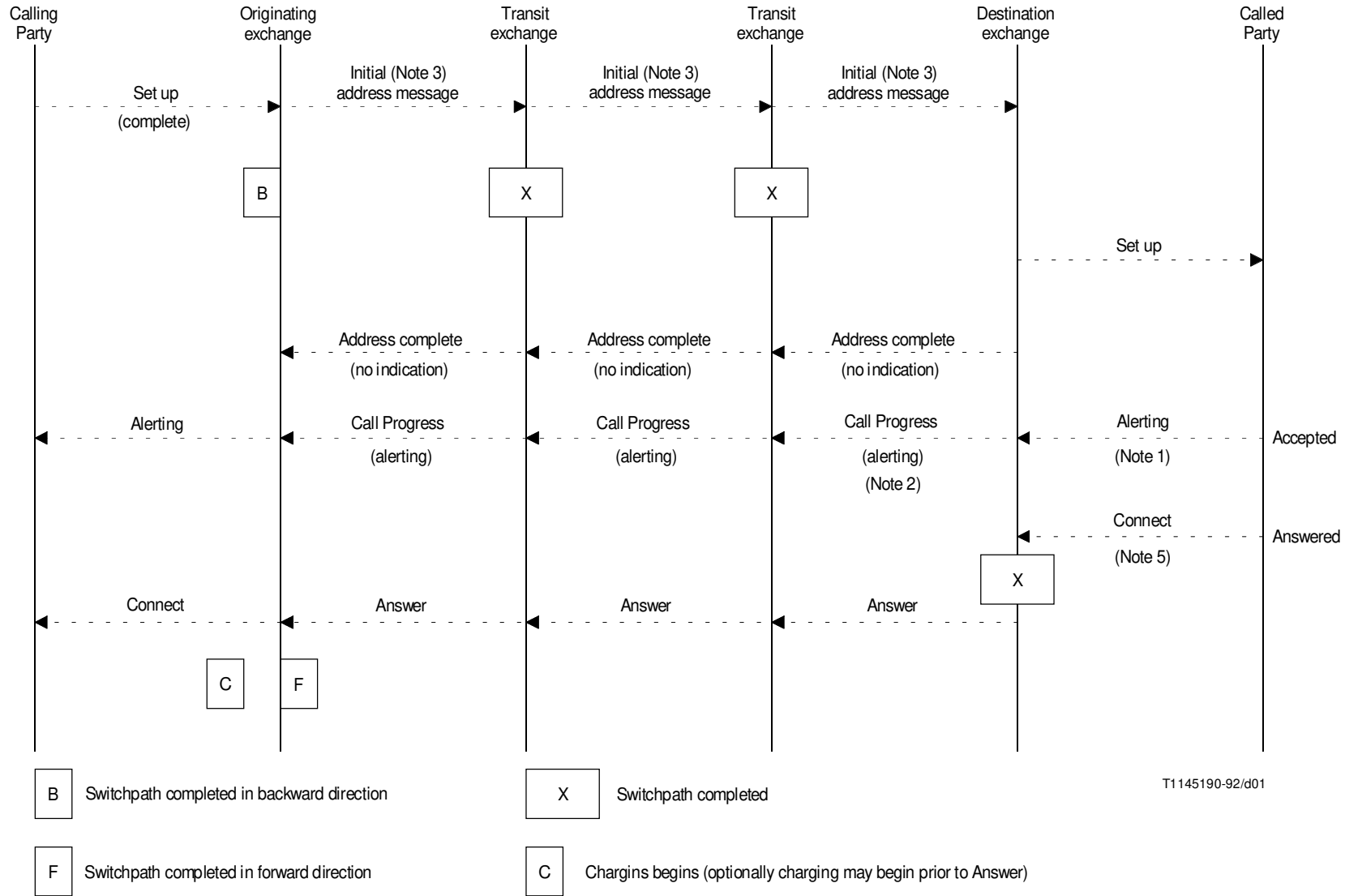

T1145190-92/d01

**Annex B**  
**Figures on basic call control signalling procedures**  
 (This annex forms an integral part of this Recommendation)

NOTE – For explanation of Notes, see at the end of Figure B.3

**FIGURE B.1/Q.764**  
**Successful ordinary call (en bloc operation)**

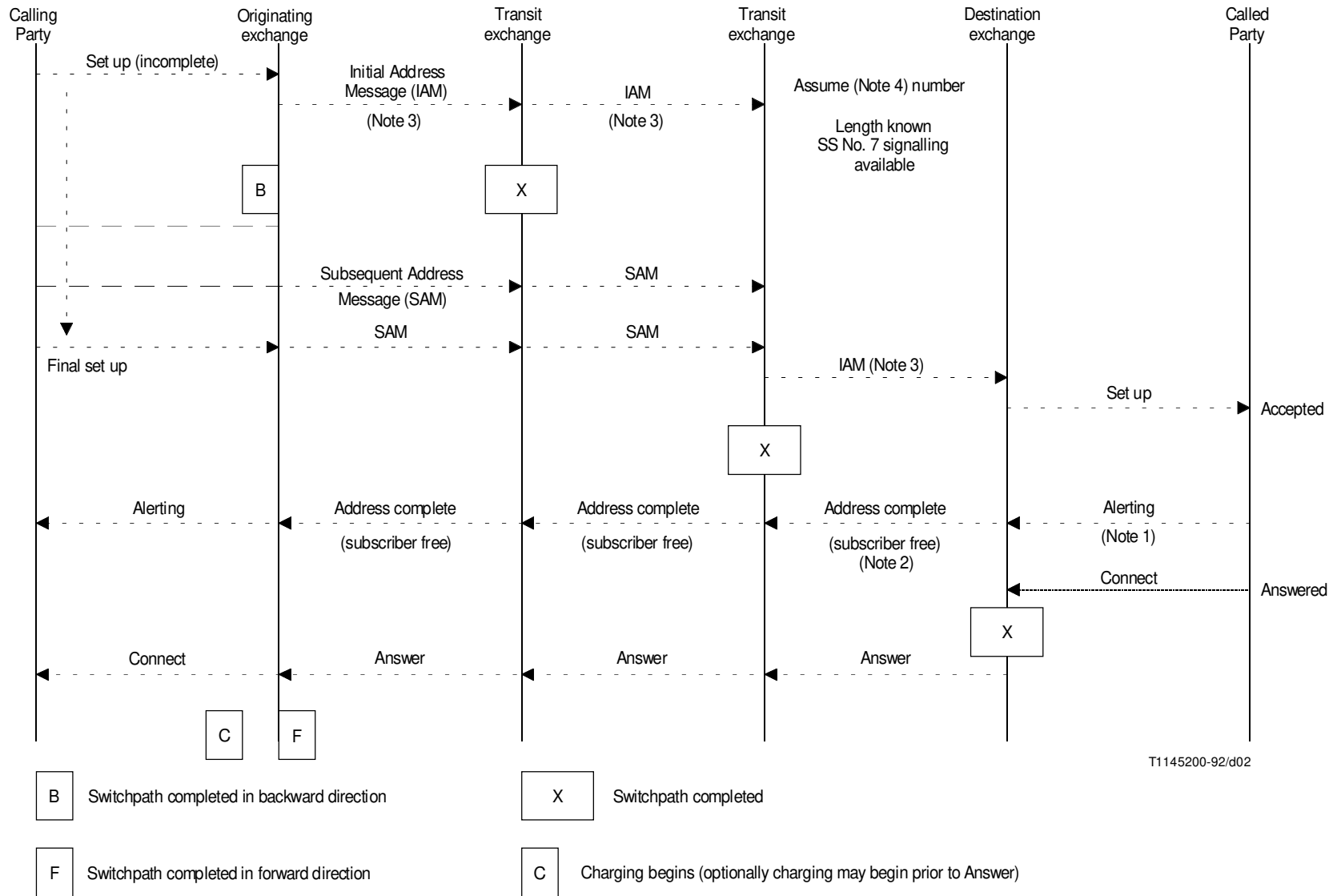

T1145200-92/d02

NOTE – For explanation of Notes, see at the end of Figure B.3

FIGURE B.2/Q.764  
Successful ordinary call (overlap operation)

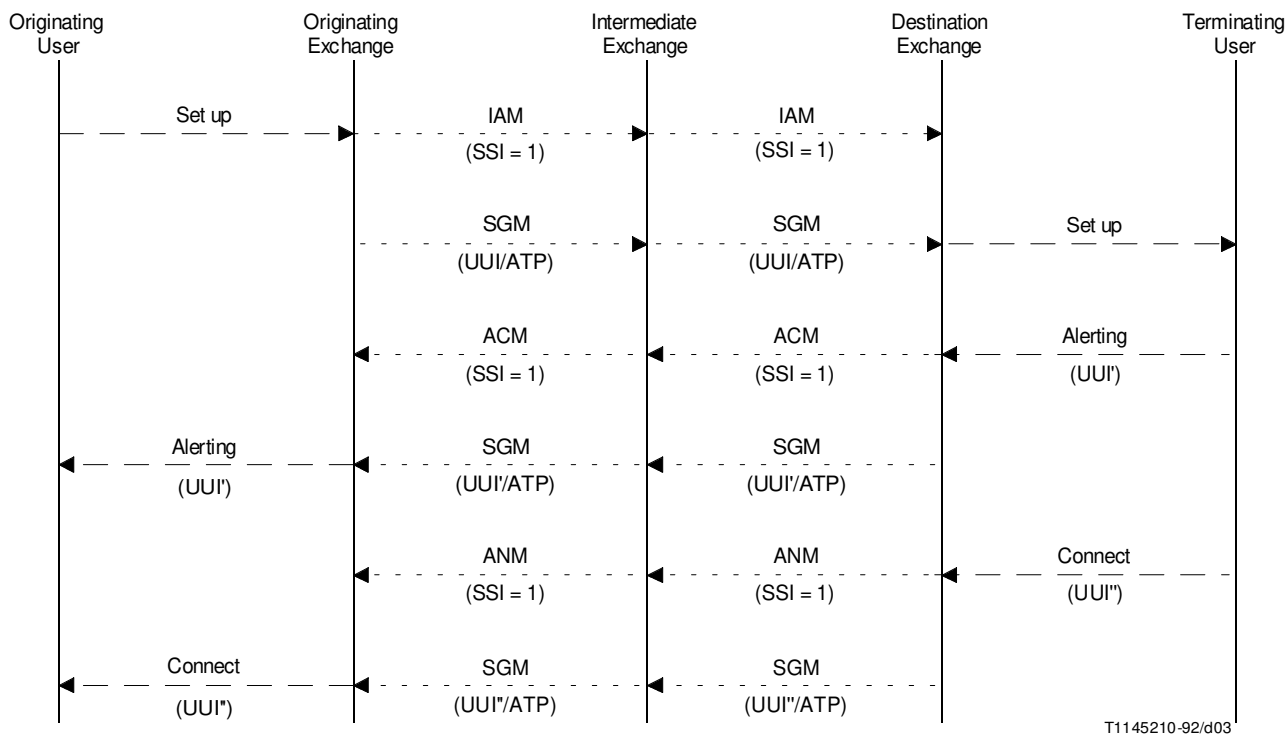

ATP Access Transport Parameter  
 UII User-to-user information  
 ACM Address Complet Message  
 ANM Answer Message  
 IAM Initial Address Message  
 SGM Segmentation message  
 SSI Simple Segmentation Indicator

FIGURE B.3/Q.764  
**Successful call involving overlength messages**

**NOTES referring to Figures B.1 to B.3**

- 1 The alerting message may not be given by a called terminal having automatic answer. Under these circumstances the Connect Message will be sent as soon as the Connect Message is received and through-connection of the speech path has been completed.
- 2 For telephone calls within the ISDN, ringing tone will be applied by the terminating exchange as soon as it is known that the subscriber is free. In the case of a PABX connected to the access interface there is the option of an early through-connection of the switch path so that the in-band call arrival indication generated in the PABX is returned to the calling user. For data calls, ringing tone is not applied.
- 3 The continuity check may be applicable on an intermediate circuit.
- 4 This example assumes that the number length is known at the second transit exchange in order to illustrate the addition of SAMs to the IAM received. This function does not have to be performed in this way.
- 5 Access protocol example is for point-to-point operation only.

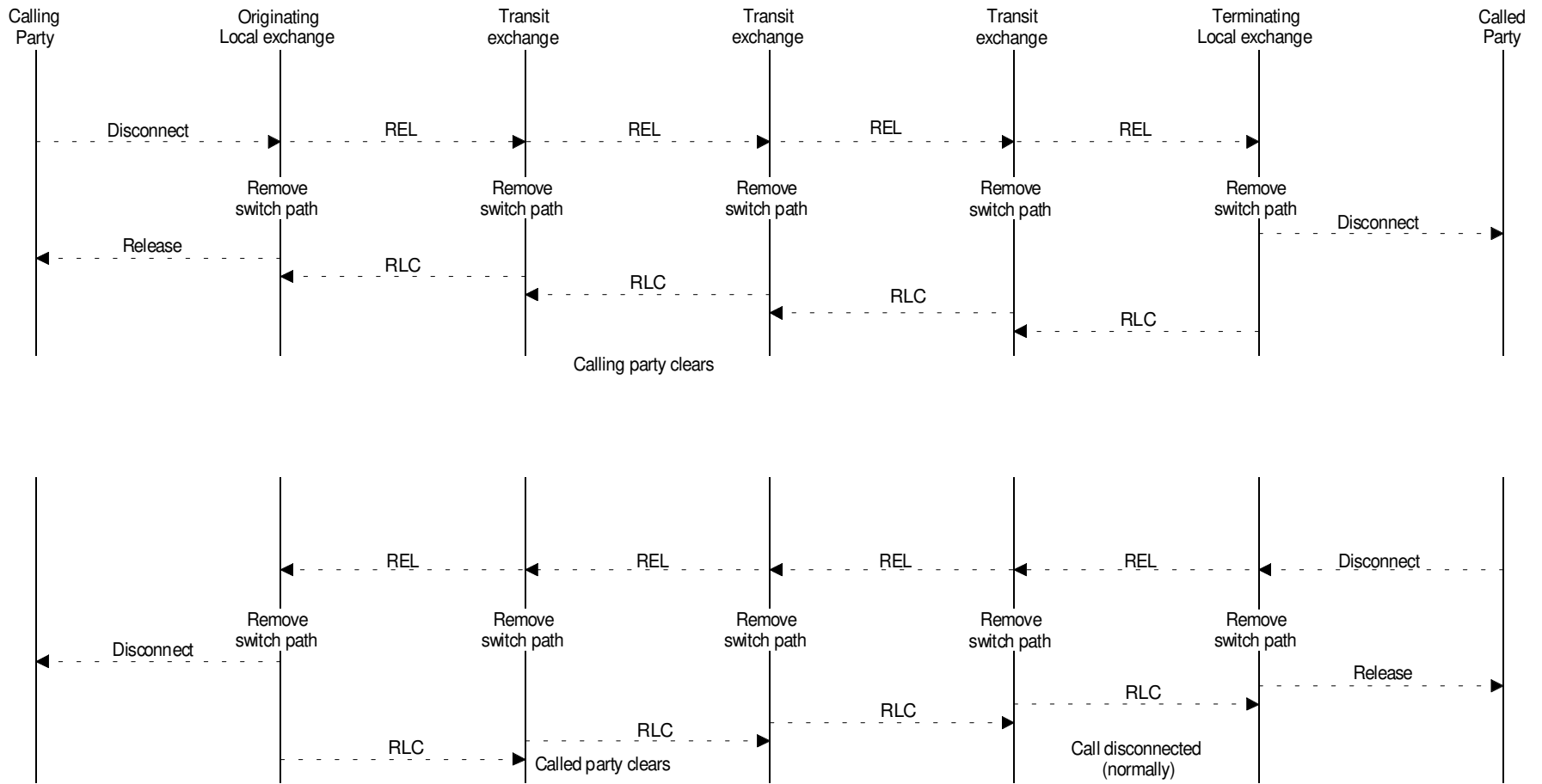

T1145220-92/d04

FIGURE B.4/Q.764  
Normal call release

## Annex C

### Examples of echo control signalling procedures

(This annex forms an integral part of this Recommendation)

The following notations are used in the figures C.1 to C.10.

|           |  |
|-----------|--|
| (o.n.i)   | Outgoing half echo control device not included   |
| (o.i)     | Outgoing half echo control device included   |
| (i.n.i)   | Incoming half echo control device not included   |
| (i.i)     | Incoming half echo control device included   |
| “o.req”   | Outgoing half echo control device requested  |
| “i.req”   | Incoming half echo control device requested  |
| T         | Start timer  |
| (*)       | Echo control device note in memory   |
| *         | Echo control device included   |
| x         | Echo control device released   |
| Ei        | Incoming echo control device   |
| Eo        | Outgoing echo control device   |
| i         | Incoming   |
| o         | Outgoing   |
| (-)       | Propagation delay below the threshold value  |
| (+)       | Propagation delay above the threshold value  |
| “Q.767”   | An exchange supporting the ISDN User Part Q.767 protocol   |
| “Q.764s”  | An exchange supporting the echo control signalling procedures according to the ISDN User Part Q.764 (1992 Recommendation) protocol   |
| “Q.764ns” | An exchange supporting the ISDN User Part Q.764 <i>Blue book</i> (1988 Recommendation) protocol or an exchange which supports the ISDN User Part Q.764 (1992 Recommendation) protocol with the exception of at least the echo control signalling procedures. |
| -         | Indications written in parenthesis are <i>Blue book</i> (1988 Recommendation) encodings (e.g. (i.i) = existing nature of connection indicator “incoming half echo control device included”).   |
| -         | Indications written in quotes are 1992 Recommendation encodings (e.g. “o.req” = an explicit request for an outgoing half echo control device).   |
| -         | If there is no explicit indication for the setting of the indicators in the echo control information parameter, the coding “no information” is assumed.  |

The set of examples is not exhaustive.

#### C.1 Echo control equipment in all exchanges

See Figure C.1.

#### C.2 Multiple forwardings

See Figure C.2.

#### C.3 Echo control equipment is not available in all exchanges

See Figure C.3.

**C.4 Echo control equipment is not available in all exchanges**

See Figure C.4.

**C.5 Interworking with signalling systems not supporting the echo control procedure in the preceding network**

**C.5.1 Interworking from Q.767**

See Figure C.5.

**C.5.2 Interworking from Q.764 not supporting the dynamic echo control procedure**

See Figure C.6.

**C.6 Interworking with signalling systems not supporting the echo control procedure in the succeeding network**

**C.6.1 Interworking to Q.767**

See Figure C.7.

**C.6.2 Interworking to Q.764 not supporting the dynamic echo control procedure**

See Figure C.8.

**C.7 Procedures after address complete – backward direction**

See Figure C.9.

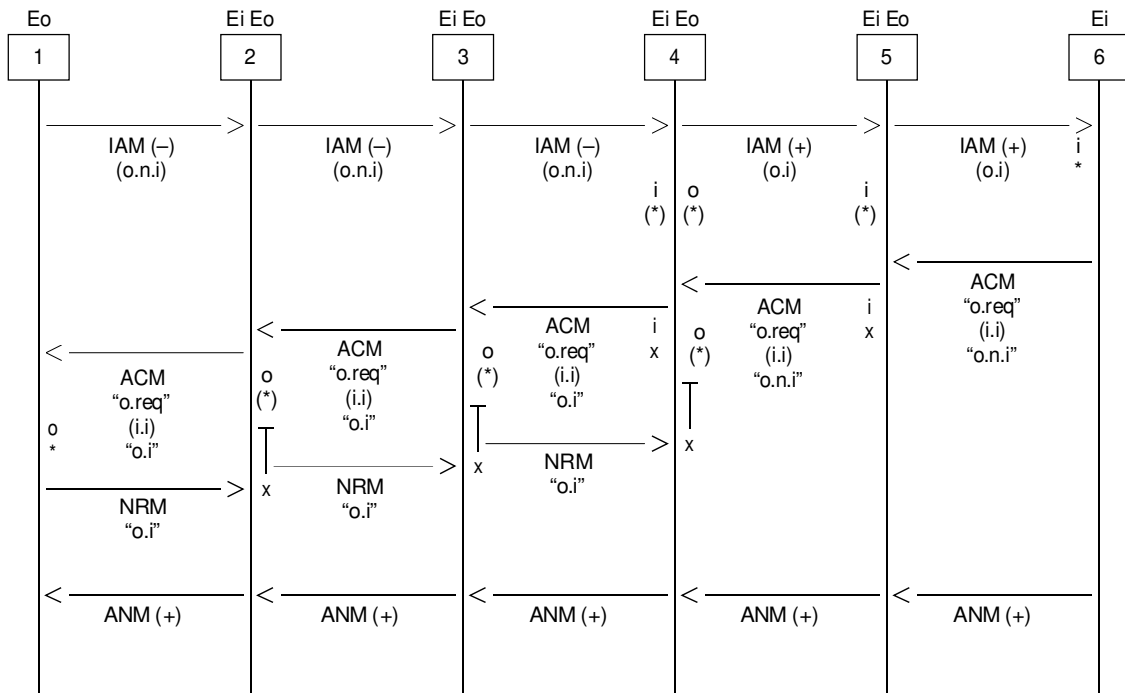

T1140560-91/d05

FIGURE C.1/Q.764

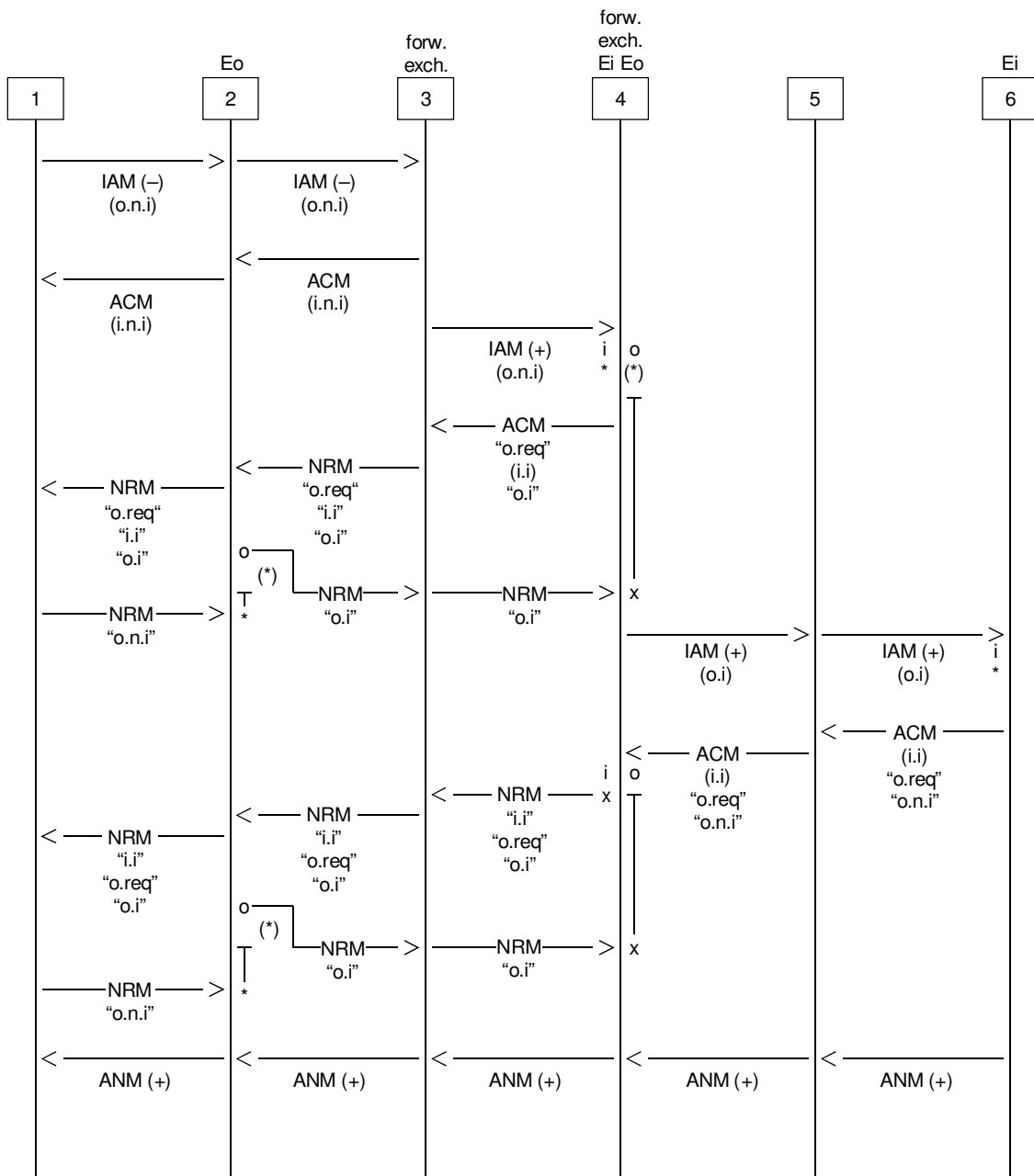

T1140570-91/d06

FIGURE C.2/Q.764



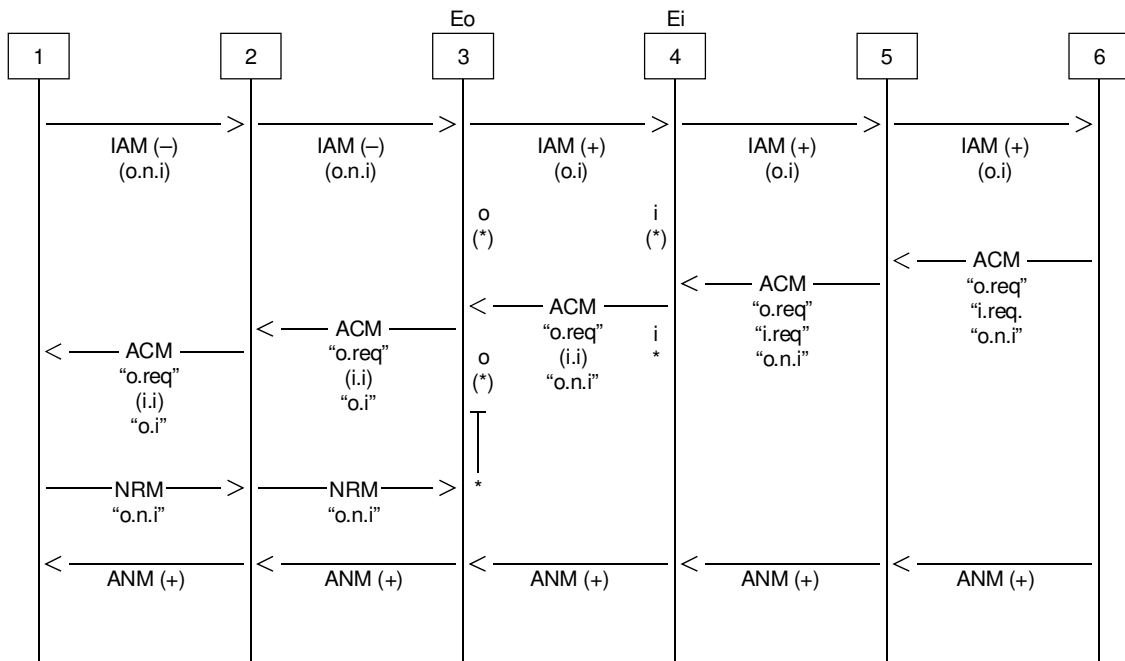

T1140580-91/d07

FIGURE C.3/Q.764

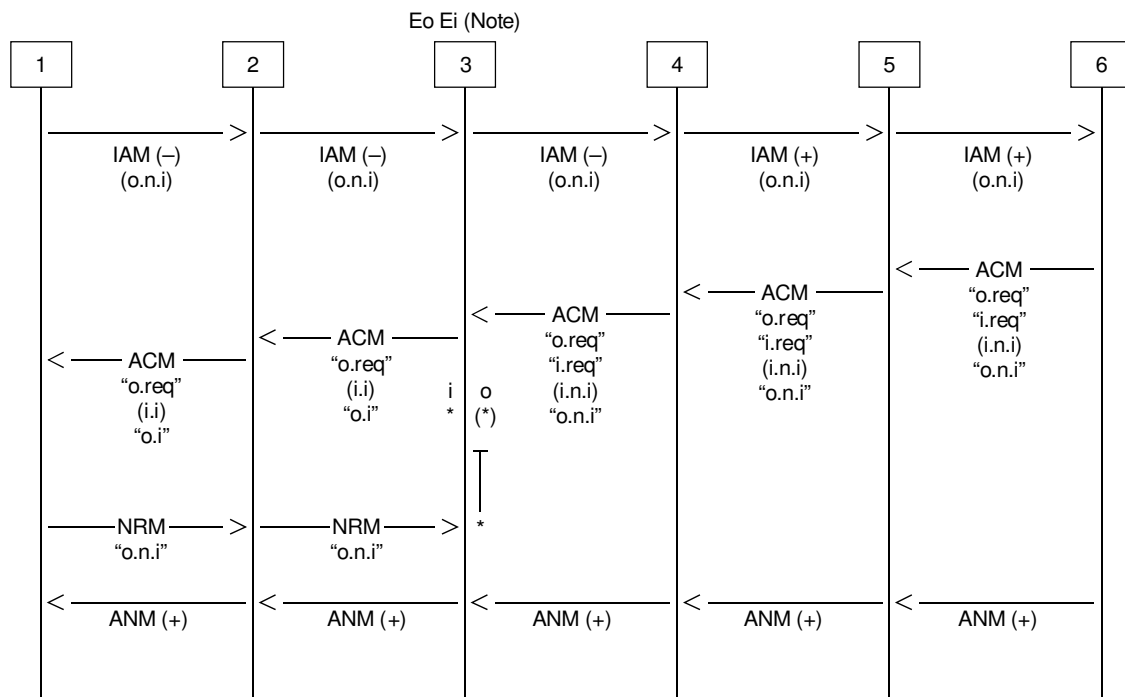

T1140590-91/d08

NOTE – In this case it is assumed that the exchange is capable of associating incoming half echo control device's to outgoing circuits and outgoing half echo control device's to incoming circuits (See 3.10.5/Q.115 revised).

FIGURE C.4/Q.764

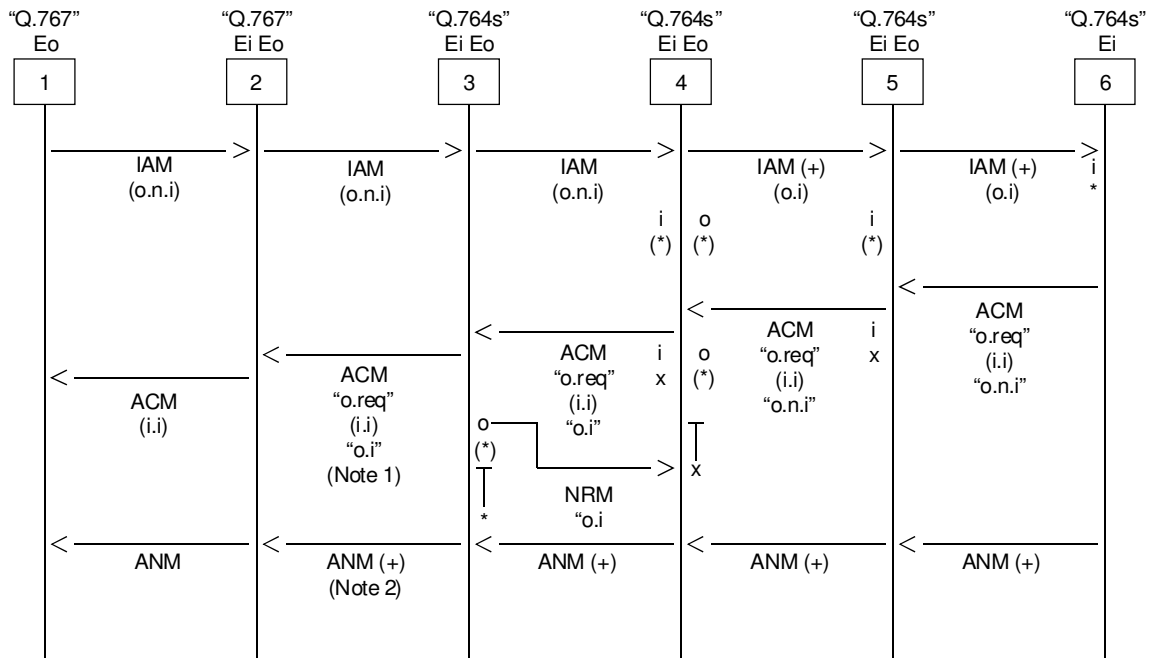

T1140600-91/d09

NOTES

- 1 The indication that an outgoing half echo control device is included and the request for an outgoing half echo control device is passed to the Q.767 exchange. It will be discarded by the Q.767 exchange.
- 2 The call history information is passed on to the Q.767 exchange. It will be discarded by the Q.767 exchange.

FIGURE C.5/Q.764

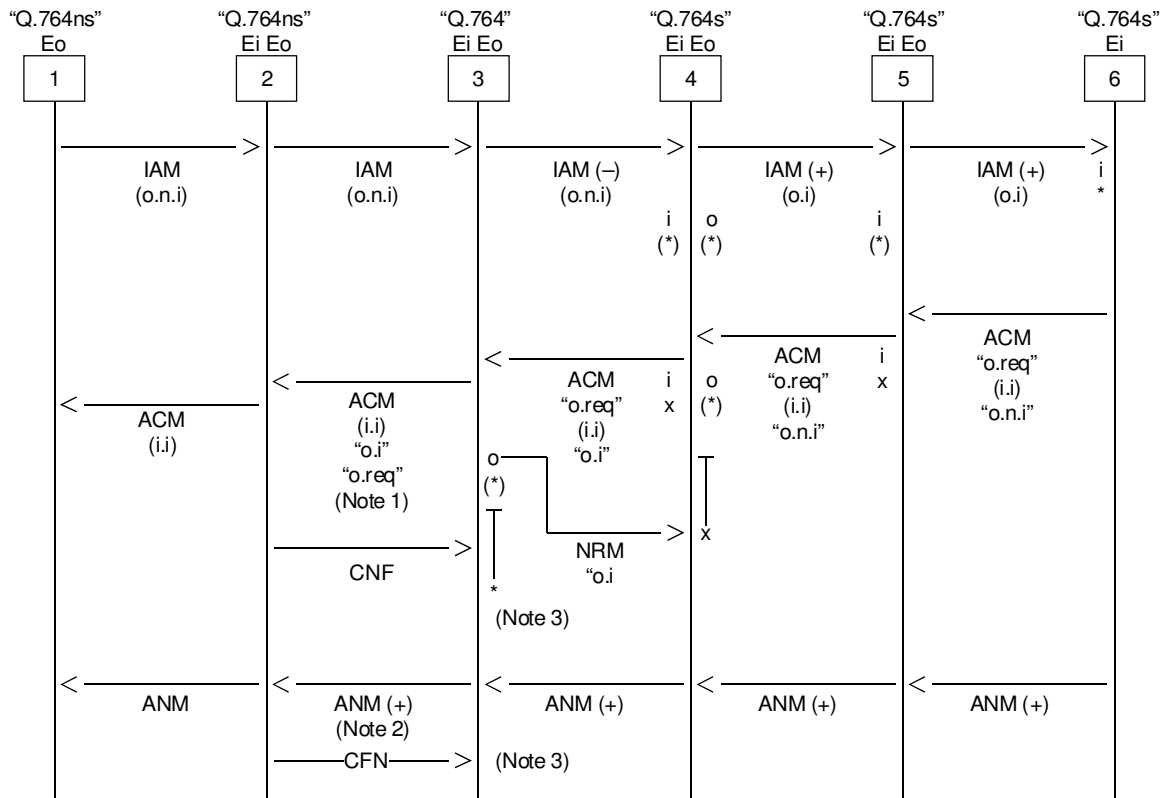

T1140610-91/d10

**NOTES**

- 1 The indication that an outgoing half echo control device is included and the request for an outgoing half echo control device is passed to the Q.764ns exchange. It will normally be discarded by the Q.764ns exchange. The Q.764ns exchange returns a confusion message indicating this.
- 2 The call history information is passed on to the Q.764ns exchange. It will normally be discarded by the Q.764ns exchange. The Q.764ns exchange returns a confusion message indicating this.
- 3 The Q.764s exchange discards the Confusion messages.

FIGURE C.6/Q.764





## C.8 Procedures after address complete – forward direction

See Figure C.10.

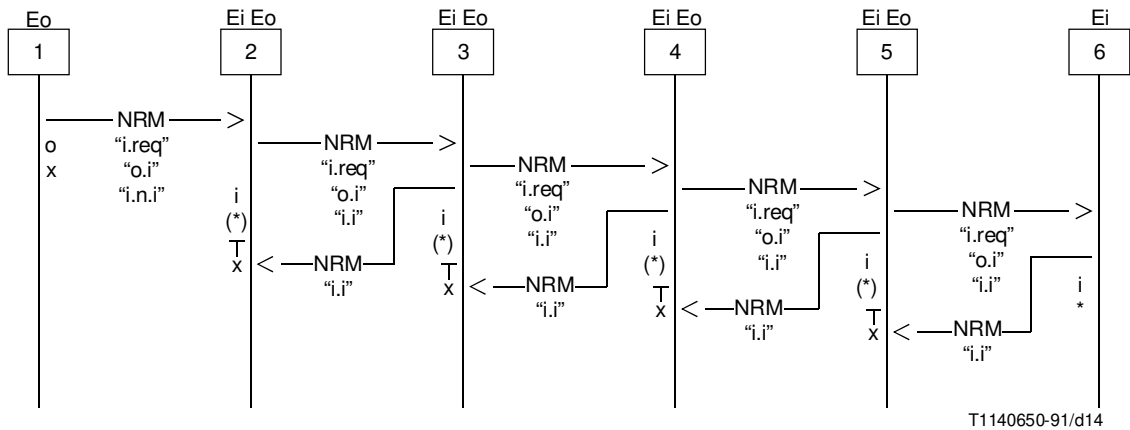

FIGURE C.10/Q.764

## Annex D

### Examples of signalling procedures for connection type allowing fallback

(This annex forms an integral part of this Recommendation)

NOTE – Description of signalling in the DSS 1 in the diagrams of this annex is illustrative only. DSS 1 protocols are defined in other Recommendations.

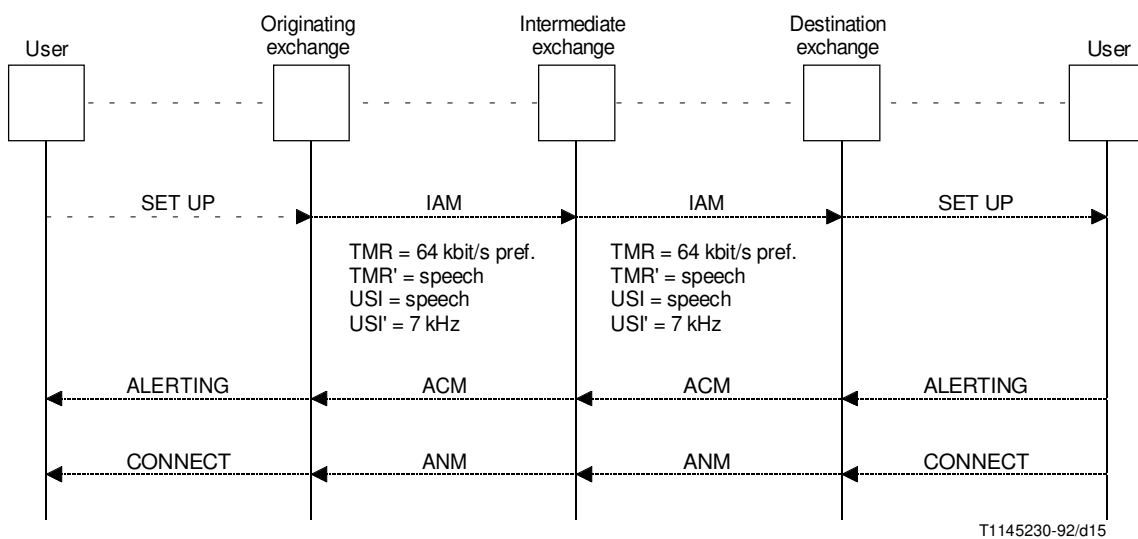
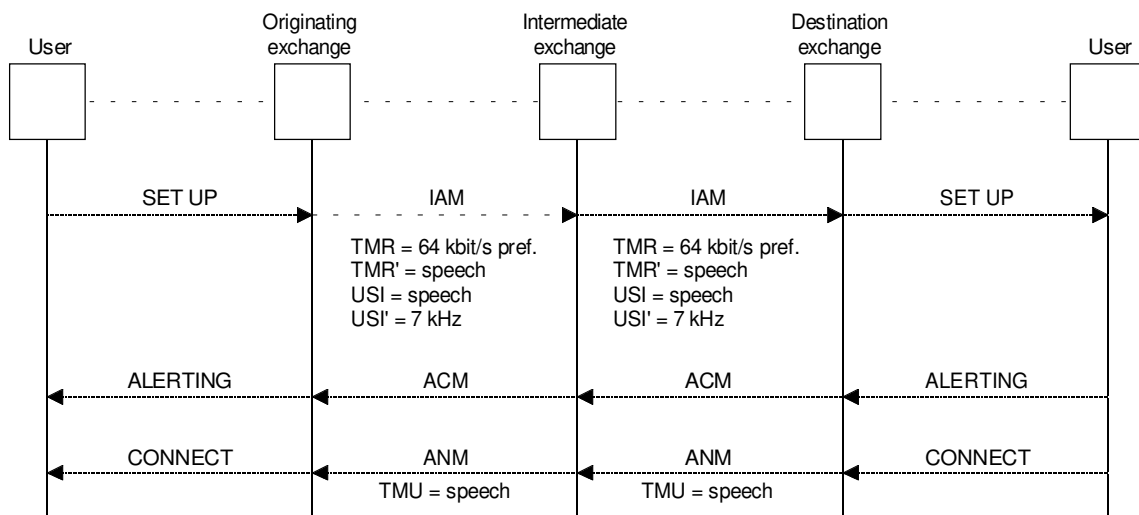

FIGURE D.1/Q.764

Fallback does not occur



T1145240-92/d16

FIGURE D.2/Q.764

**Fallback occurs to speech at the destination interface.  
Fallback indicated in connect**

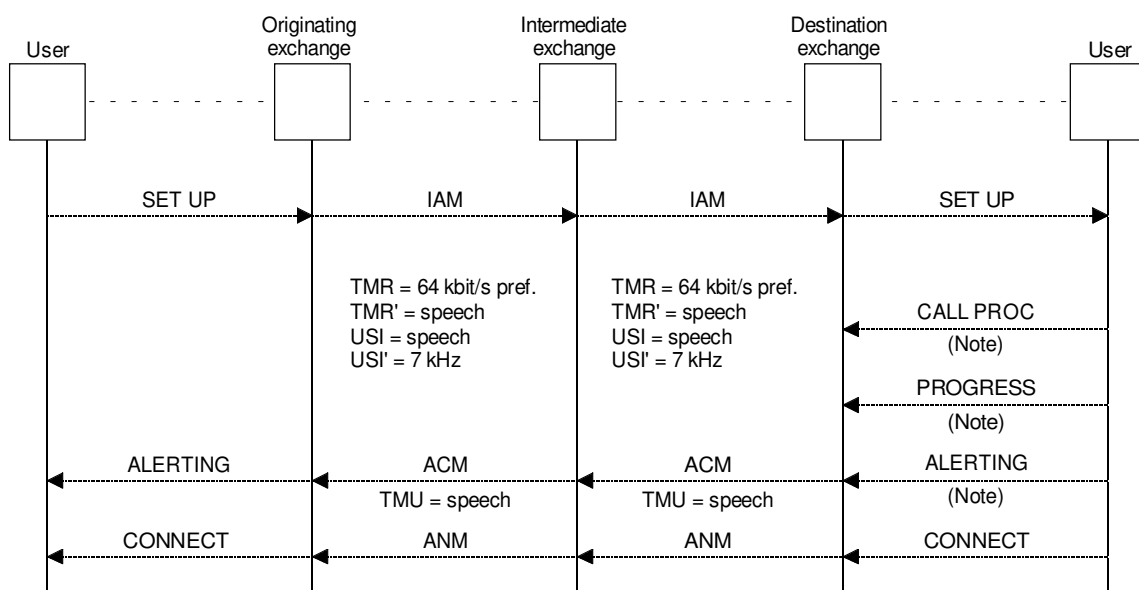

T1145250-92/d17

NOTE – Fallback is indicated by the access.

FIGURE D.3/Q.764

**Fallback occurs to speech at the destination interface. Fallback  
indicated in alerting or any message before alerting**

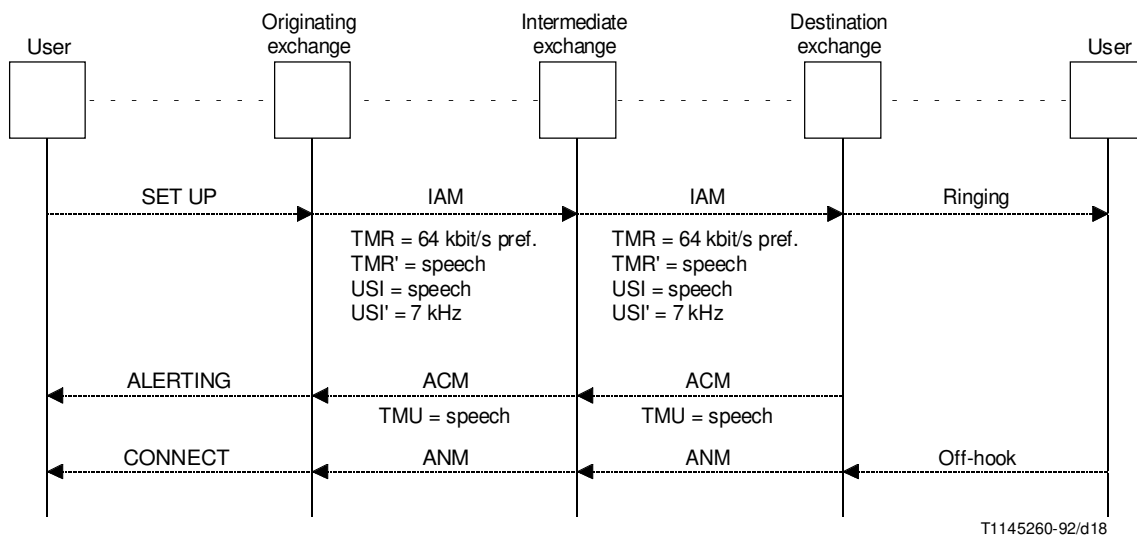

FIGURE D.4/Q.764  
Fallback when called user is non-ISDN

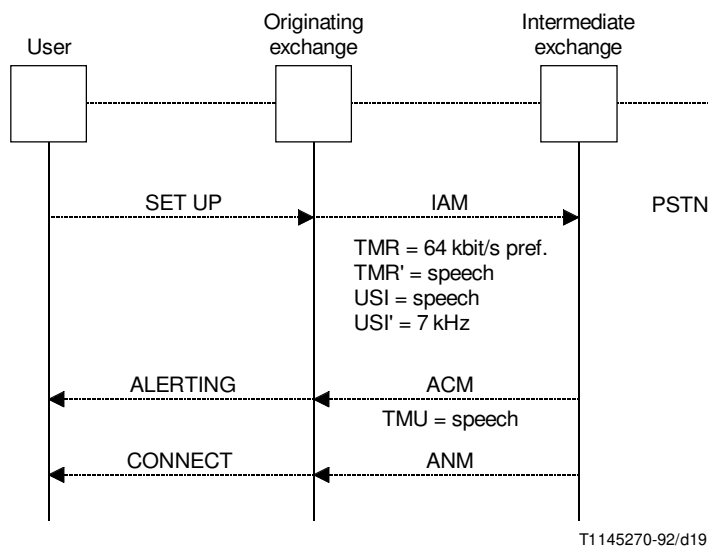
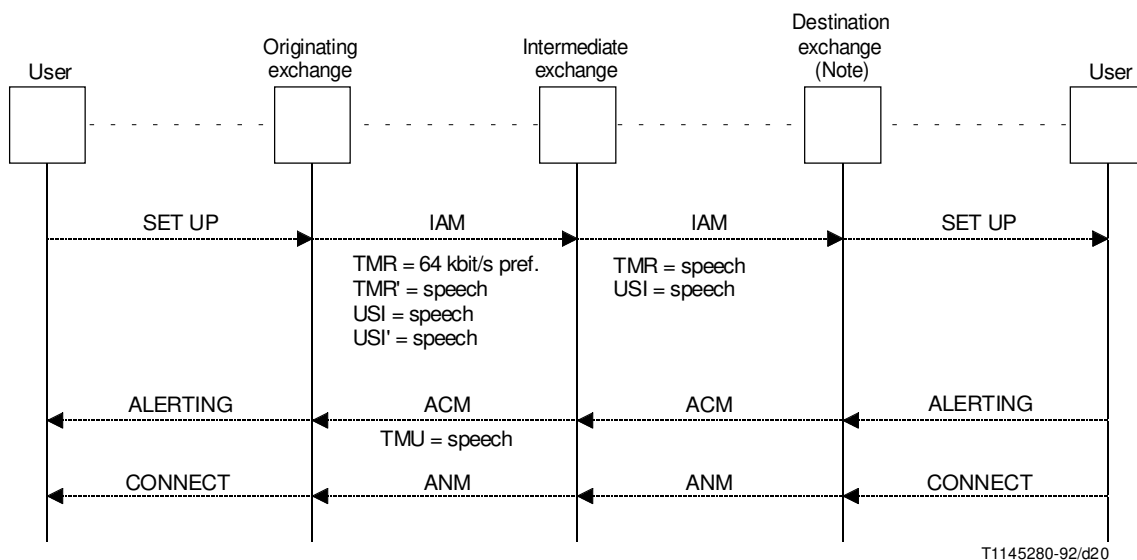

FIGURE D.5/Q.764  
Fallback when interworking with PSTN





NOTE – Q.767 or Q.764 exchange not supporting the fallback procedure.

T1145280-92/d20

FIGURE D.6/Q.764

**Fallback when interworking with version of ISDN User Part which does not support the fallback procedure**

## Annex E

### Test calls

(This annex forms an integral part of this Recommendation)

#### E.1 Called number for test calls

This subclause only describes the sending sequence of forward address information in the case of test calls based on bilateral agreements.

i) Called party number:

nature of address indicator: "0000011" national significant number

address:

- access code N1 ... Nn based on bilateral agreements
- sending finished: ST

ii) Calling party's category:

"00001101" test call

#### E.2 Accounting of test calls

In international accounts, tests should be deducted according to Recommendation D.390 R7.

## **Annex F**

### **Cause values**

(This annex forms an integral part of this Recommendation)

This annex contains clarification of the usage of cause values and the handling of location indicators on the international interface.

This information can be found in Recommendation Q.850.

## **Annex G**

### **Start up procedures**

(This annex forms an integral part of this Recommendation)

The start up procedure for ISDN User Part circuits is a manually controlled procedure. It is initiated by each exchange for its outgoing circuits. Bidirectional circuits are tested by both sides.

During the process of placing circuits into service, unacknowledged circuit supervision messages will most likely be reported to maintenance systems. In order to minimize this impact, it is recommended that coordination takes place between exchanges and established procedures for placing circuits into service be followed. Lack of coordination may result in inefficient use of exchange and maintenance resources.

Before the test itself, some exchanges, named exchanges of type A, do not require anything before the test call, and only respond to received group reset (reset) messages with a group reset acknowledgement (release complete/blocking) message. Other exchanges, named exchanges of type B, do require a group reset/group reset acknowledgement (or reset/release complete) message cycle before the continuity check or the conversation test is performed.

The start up procedure necessary for exchanges of type B is intended both for unidirectional and bidirectional circuits in accordance with G.1 and G.2 below.

Possible relations are:

A - - - - > A

A - - - - > B

B - - - - > A

B - - - - > B

Abbreviations used in messages sequences:

|      |  |
|------|--|
| GRS  | Group reset                              |
| GRA  | Group reset acknowledgement              |
| RSC  | Reset                                    |
| RLC  | Release complete                         |
| IAM  | Initial address message                  |
| ACM  | Address complete message                 |
| ANM  | Answer message                           |
| CGB  | Circuit group blocking                   |
| CGBA | Circuit group blocking acknowledgement   |
| CCR  | Continuity check request                 |
| CGU  | Circuit group unblocking                 |
| CGUA | Circuit group unblocking acknowledgement |
| COT  | Continuity                               |

### G.1 Initial procedure for putting the first group of circuits into service

- a) exchange A ----> exchange A  
No initial procedure required.
  - b) exchange A ----> exchange B  
    <---GRS-----  
    ----GRA---->
  - c) exchange B ----> exchange A  
    ----GRS---->  
    <---GRA-----
  - d) exchange B -----> exchange B  
    ----GRS---->           <---GRS-----  
    <---GRA-----           ----GRA---->
- or
- <---GRS-----           ----GRS---->
  - GRA---->           <---GRA-----

NOTE – It is also possible to have individual reset circuit messages. The diagrams do not intend to cover all possible exchange of messages (see 2.9.3).

### G.2 Initial procedure for putting additional circuits into service

- a) exchange A ----> exchange A  
No initial procedure required.
  - b) exchange A ----> exchange B  
    <---RSC-----  
    ----RLC---->
  - c) exchange B ----> exchange A  
    ----RSC---->  
    <---RLC-----
  - d) exchange B -----> exchange B  
    ----RSC---->           <---RSC-----  
    <---RLC-----           ----RLC---->
- or
- <---RSC-----           ----RSC---->
  - RLC---->           <---RLC-----

### G.3 Test procedures

This subclause describes two different test procedures (named A and B) for the initial testing of circuits. As a minimum, it is required that an international exchange can actively perform one of these test procedures and respond to the other procedure.

Each exchange checks its own circuits. Bidirectional circuits are checked by both ends.

- a) Procedure using a conversation test  
    ----IAM(test) ---->  
    <-----ACM-----  
    <-----ANM-----  
    Conversation test  
    -----REL ----->  
    <-----RLC-----

b) Procedure using the continuity check procedure

The continuity check procedure is used for the start up procedure, even if no continuity check is required during normal operation of the circuits.

exchange A or B ----- exchange A or B

test initiating exchange

-----CGB----->

<-----CGBA-----

1)

-----CCR----->

2)

tone ----->-----

evaluation -----<----- | loop

3) if the test is OK

-----REL----->

<-----RLC-----

4) the circuit is in the idle state blocked

5) perform the CCR, REL, RLC sequence for all remaining trunks that are to be brought into service.

6)

-----CGU----->

<-----CGUA-----

7) the trunks are in service

8) if the test is not OK

9)

-----COT(fail)---->

10)

-----CCR----->

11)

tone ----->-----

evaluation | -----<----- loop

12) if the test is OK, continue as 3)

13) if the test is not OK, report circuit identification code, do not unblock trunk for outgoing traffic and continue continuity check requests on the trunk, then continue in 5).

NOTE – It is also possible to have individual blocking messages. The diagrams do not intend to cover all possible exchange of messages (see 2.9.2).