



INTERNATIONAL TELECOMMUNICATION UNION

ITU-T

TELECOMMUNICATION
STANDARDIZATION SECTOR
OF ITU

Q.730

(03/93)

**SPECIFICATIONS OF
SIGNALLING SYSTEM No. 7**

**SIGNALLING SYSTEM No. 7 –
ISDN SUPPLEMENTARY SERVICES**

ITU-T Recommendation Q.730

(Previously “CCITT Recommendation”)

FOREWORD

The ITU Telecommunication Standardization Sector (ITU-T) is a permanent organ of the International Telecommunication Union. The ITU-T is responsible for studying technical, operating and tariff questions and issuing Recommendations on them with a view to standardizing telecommunications on a worldwide basis.

The World Telecommunication Standardization Conference (WTSC), which meets every four years, established the topics for study by the ITU-T Study Groups which, in their turn, produce Recommendations on these topics.

ITU-T Recommendation Q.730 was revised by the ITU-T Study Group XI (1988-1993) and was approved by the WTSC (Helsinki, March 1-12, 1993).

NOTES

1 As a consequence of a reform process within the International Telecommunication Union (ITU), the CCITT ceased to exist as of 28 February 1993. In its place, the ITU Telecommunication Standardization Sector (ITU-T) was created as of 1 March 1993. Similarly, in this reform process, the CCIR and the IFRB have been replaced by the Radiocommunication Sector.

In order not to delay publication of this Recommendation, no change has been made in the text to references containing the acronyms "CCITT, CCIR or IFRB" or their associated entities such as Plenary Assembly, Secretariat, etc. Future editions of this Recommendation will contain the proper terminology related to the new ITU structure.

2 In this Recommendation, the expression "Administration" is used for conciseness to indicate both a telecommunication administration and a recognized operating agency.

© ITU 1994

All rights reserved. No part of this publication may be reproduced or utilized in any form or by any means, electronic or mechanical, including photocopying and microfilm, without permission in writing from the ITU.

CONTENTS

	<i>Page</i>
1 General	1
1.1 Exceeding the maximum message length	1
1.2 Network specific facilities (national option).....	1
1.3 Generic procedures	2
1.4 End-to-end signalling	5
1.5 Layout of service Recommendations	18
1.6 List of supplementary services	19
1.7 Association of supplementary services to bearer services and teleservices.....	21
1.8 Definition of supplementary services	21
Appendix I – Contents of the interface elements between the ISDN user part and the SCCP	21
I.1 Contents of the REQUEST type 1.....	21
I.2 Contents of the REQUEST type 2.....	22
I.3 Contents of the REPLY	22

SIGNALLING SYSTEM No. 7 – ISDN SUPPLEMENTARY SERVICES

(Melbourne, 1988; modified at Helsinki, 1993)

1 General

This Recommendation describes the format for supplementary services contained in Recommendations Q.731 to Q.737, and is to be used in conjunction with the ISDN user part (ISUP) defined in Recommendations Q.761 to Q.764, and Recommendation Q.767 “Application of the ISDN user part of CCITT Signalling System No. 7 for international ISDN interconnections”.

Each type of supplementary service will be defined in separate sections of its respective Recommendation, each containing the complete procedures encompassing both the ISDN user part and the procedures to be used on the top of transaction capability (TC) where appropriate.

Each section contains a general paragraph giving details of the specific service with reference to the stage 1, 2 and 3 descriptions defined in the Recommendations of the I.250-Series, the Q.80-Series and the Q.950-Series. The call set-up procedures and the actions taken at the concerned exchanges are defined. Arrow diagrams showing the message flows for both successful and unsuccessful establishment of the service are generally included. The formats and coding aspects are not defined in this Recommendation but references are made out to the appropriate ISDN user part, TC or signalling connection control part (SCCP) Recommendations.

1.1 Exceeding the maximum message length

If for any reason the combination of basic plus supplementary service information causes the overall maximum length (e.g. ISDN user part 272 octets) of the message (e.g. initial address message) to be exceeded, then the procedures for simple segmentation given in 2.1.12/Q.764 shall be applied. If these procedures fail to reduce the message length below the required maximum, then the procedures of 2.15/Q.764 (over-length messages) shall be applied.

1.2 Network specific facilities (national option)

Service-related information may be transferred in the network-specific facilities parameter in both directions between the local exchange and the identified network which controls the service. Information to be included in this parameter is specified nationally. Examples of the information included in this parameter are as follows.

a) *Transfer of network-specific facilities information*

If the network-specific facilities information element specified in Recommendation Q.931 is received from the access signalling system, this information is passed unchanged to the identified network in the network-specific facilities parameter.

An exchange which controls a service may generate the network-specific facilities information. This information is passed unchanged to the relevant exchange.

b) *Transfer of stimulus information elements*

Stimulus type of Q.932 information elements, e.g. keypad facility information, may be included in the network-specific facilities parameter in call control messages at the local exchange. In this case, the local exchange will identify the destination network of the information by an appropriate method, and generate the network identification fields.

When this option is applied to the network, the exchange which controls a service may generate Q.932 information elements, e.g. display information, and this information is passed unchanged to the relevant exchange in the network-specific facilities parameter in call control messages.

Multiple Q.932 information elements may be included in a network-specific facilities parameter.

1.2.1 Sending unsolicited information (national use)

Information that is available at an exchange and that does not correspond to information which can be or has been requested by an information request message, can be sent in the information message with the solicited information indicator set to signify that the message has been sent unsolicited.

An unsolicited information message can be sent in either direction in any call state (except in the awaiting release complete state).

Parameters that can be requested via an information request message should not be put in an unsolicited information message, and these parameters will be discarded by the outgoing international, incoming international or destination exchanges.

1.3 Generic procedures

1.3.1 Service activation (national use)

1.3.1.1 General description

The procedure described in this subclause gives a node in the signalling network the capability to request a simple action to be performed at another node. The procedure can also be used to report the acceptance or rejection of the requested action. The procedures described in this subclause can only be used if no additional information specific to the requested action or its acknowledgement needs to be included in the message, unless that information is provided for other purposes as well.

If additional information specific to the requested action or its acknowledgement is to be sent and if this information is not provided in the message for other purposes, other procedures such as the remote operations capability described in 1.3.3 should be used.

1.3.1.2 Service activation procedure

Whenever a node in the signalling network determines that there is a need for simple supplementary service invocation at another node or to report the outcome of such a request, the node will indicate such a request or outcome of the request by including the service activation parameter in a call control message of end-to-end significance or in the facility message if no appropriate call control message is available.

The service activation parameter can be used either in a request-response node limited to one cycle or in a unidirectional node.

It is possible to include multiple feature codes in a single service activation parameter. In such a case, individual services are handled independently of each other.

The assignment of the feature code and the actual usage of the service activation parameter is up to individual supplementary service definition.

1.3.1.3 Error procedures

The error handling procedures described in Recommendation Q.764 are also applicable to service activation procedures.

1.3.2 General digit transfer (national use)

This capability enables supplementary services to transfer digit information, which cannot suitably be sent within any numbering address parameter, in a Generic digit parameter. A Generic digit parameter is transported in an initial address message. Whether or not a Generic digit parameter can be transported in other call control messages is left for further study. Multiple generic digits parameter may be transported in any one message qualified to carry this parameter.

The Generic digit parameter is generated by the exchange invoking a service. This parameter is passed unchanged to the relevant exchange.

Examples of digit information in the Generic digit parameter are account code and authorization code.

1.3.3 Remote Operations service (ROSE) capability (national use)

1.3.3.1 General description

The procedures described in this subclause give a node in the signalling network the capability to request that a particular operation be performed at a remote node; the remote node attempts to perform the operation and then reports the outcome of the attempt.

The generic structure of an operation is an elementary request/reply interaction. Remote operations provide in a structured way, interactive capability which allows nodes to request an operation and receive result or error indications depending on the outcome of the operation. Remote operations service is defined in Recommendation X.219 and the protocol in X.229.

The remote operation procedure makes use of the remote operations parameter. The format of this parameter is provided in Recommendation Q.763. This parameter can be carried in any call control message of end-to-end significance and if there is no call control message available, the remote operations parameter can be carried in the facility message. The format of this message is provided in Recommendation Q.763.

In addition, the use of the facility message allows the actions and events related to supplementary services to be clearly separated from those associated with basic call control, hence providing improved stability to the basic call control procedures of Recommendation Q.764.

The supplementary services definition will make use of this capability along with the basic call control procedures described in Recommendation Q.764.

1.3.3.2 Remote operations procedure in ISDN user part

Whenever a node determines that there is a need to invoke an operation at the remote node, the originating node will format a remote operations parameter containing the invoke component which will include the appropriate operation code and the associated parameters. The remote operations parameter is sent in any call control message of end-to-end significance if one is available, otherwise the facility message is used.

Intermediate nodes may attempt to perform the operation upon receipt of this parameter. If the intermediate node does not understand the operation, it shall pass it to the next node. Similarly, any results or rejects not used by the intermediate nodes shall be passed to the next node.

The terminating node will attempt to perform the operation. If the operation can be successfully performed, the outcome is reported in the remote operations parameter containing a return result component and related parameters. If the operation was unsuccessful, a result error component is included in the remote operations parameter instead of the return result component. If a problem is detected in the requested operation, a reject component is sent. The remote operations parameter is sent in any call control message if one is available, otherwise the facility message is used to send this parameter to the originating node.

1.3.3.3 Error performance

When the remote operations parameter is not recognized by a node, the compatibility procedure described in Recommendation Q.764 is applicable.

If a node is unable to process a remote operations parameter included in a call control message, then the following options apply:

- a) The node may reject the call request. The call request is cleared using procedures described in Recommendation Q.764. A return error or a reject component with appropriate parameter(s) is also sent to the originating node indicating termination node's inability to process remote operations parameter.
- b) The node may continue to process the call request according to normal call control procedures and reject the supplementary service invocation by sending a return error or a reject component with appropriate parameter(s) in the remote operations parameter. This parameter can be sent either in the facility message or in any appropriate call control message.

- c) The node may continue to process the call request according to normal call control procedures and ignore the supplementary service invocation. In this case, the supplementary service at the originating node, which requested the supplementary service invocation at a remote node, will have to recover from the non-receipt of a reply.

The choice of an option depends on the individual supplementary service procedures.

If a node is unable to process a remote operations parameter included in the facility message then the following options apply:

- a) The node may clear the call using procedures described in Recommendation Q.764. The node will also send a return error or a reject component with appropriate parameter(s) in a remote operations parameter. This parameter will be sent either in the facility message or in any appropriate call control message.
- b) The node may continue with the call but reject the supplementary service invocation. A return error or a reject component with appropriate parameter(s) in the remote operations parameter is sent to the originating node. The remote operations parameter is sent either in a facility message or any appropriate call control message.
- c) The node may ignore the supplementary service invocation. In this case, the supplementary service at the originating node, which requested the supplementary service invocation at a remote node, will have to recover from the non-receipt of a reply.

The choice of an option depends on the individual supplementary service procedures.

If a call is cleared and there is an operation pending, the operation is aborted and no response is sent to the originating node. The supplementary service at the originating node will have to recover from this situation.

The supplementary service procedures will clearly describe the handling of components and error procedures specific to the service.

1.3.3.4 Library of operation and error values

This subclause lists the allocated INTEGER values for operations and errors to be assigned to operations of supplementary services within the Q.730-Series Recommendations. The individual ERROR values are complemented by a brief definition of the error characteristics.

1.3.4 Generic notification procedure

This capability enables supplementary services to transfer a notification indicator indicating an event which has occurred as the result of service invocation, in a Generic notification parameter, to either an originating user or a terminating user. A Generic notification indicator parameter is transported in either direction in any call control message of end-to-end significance after an initial address message. Multiple generic notification parameters may be transported in any one message qualified to carry this parameter.

The Generic notification parameter is generated either by a user or inside the network where the relevant service is invoked. The contents of the notification indicator is passed unchanged inside the network and delivered to the user.

1.3.5 Generic number transfer

This capability enables supplementary services to transfer a numbering address information indicating a number based on either a standardized or a service-specific numbering plan. A Generic number parameter is transported in either direction in an initial address message, answer message or connect message. Multiple generic number parameters may be transported in any one message qualified to carry this parameter. Whether or not a Generic number parameter can be transported in other call control messages is left for further study.

The number information is generated either by a user or a local exchange. The contents of the number information may be processed and changed inside the network.

1.4 End-to-end signalling

1.4.1 Introduction

End-to-end messages contain only information which is relevant for the “endpoints” of a circuit-switched connection. Endpoints are signalling points such as local exchanges, international gateway exchanges and possibly exchanges at other network boundaries, e.g. gateway exchanges within the Signalling System No. 7 network. Two methods are available for ISDN end-to-end signalling:

- the pass-along method; and
- the signalling connection control part (SCCP) method.

The choice of method is, to some extent, dependent on the size and architecture of the signalling network. Both methods may coexist in a given network.

The pass-along method and the SCCP method are specified for circuit-switched connections.

An end-to-end signalling connection established for end-to-end signalling is called an “ISDN user part end-to-end signalling connection” in this subclause.

1.4.2 Pass-along method (national use)

In the pass-along method, use is made of an ISDN user part end-to-end signalling connection which is set up whenever a physical connection between two endpoints is established.

The ISDN user part end-to-end signalling connection in this case consists of a number of connection sections in tandem which run in parallel with and use the same circuit identification code (CIC) as the circuits in the physical connection.

The pass-along method defines, section by section, the appropriate routing label for the message to be passed along via ISDN user part connection, but the content of pass-along messages is only evaluated and possibly changed at the endpoints. The pass-along message is characterized by a special message type code as specified in Recommendation Q.763. One ISDN user part message to be passed along may be embedded in one pass-along message.

In a signalling connection for which pass-along method is available, pass-along messages may be sent in either the forward or backward direction.

A forward pass-along message may not be sent until either a backward pass-along or a backward set-up message indicating pass-along method available has been received, or after the physical connection is released.

Call control path information (see 1.4.5) included in the initial address and backward set-up messages is used to indicate to the connection endpoints whether or not the call control path can support pass-along message transfer.

A pass-along message that has been received at a transit exchange and cannot be transferred to the subsequent exchange is discarded without affecting call states and timers in that exchange.

1.4.3 SCCP method

In the SCCP method the ISDN user part employs the services of the signalling connection control part (SCCP) for the transfer of end-to-end signalling information.

1.4.3.1 Call reference (national use)

The call reference is a circuit independent information identifying a particular call. It is needed when end-to-end signalling information associated with the call is to be transferred by a connectionless SCCP service. If a SCCP connection request for a connection-oriented SCCP service is carried embedded in an ISDN-UP message, the call reference is omitted.

References for a given call are allocated independently in the two concerned signalling points and are subsequently exchanged. The allocation of call references may be initiated by either side. The call reference consists of a call identity and the point code where the call identity is established. If, e.g. signalling point A initiates the exchange of call references, it selects a call identity CIA and transfers it together with the point code of A, PCA, to signalling point B.

Signalling point B then allocates its own identity CIB to the call and returns it together with the signalling point code of B, PCB, to signalling point A. Subsequent call-related end-to-end messages transferred from signalling point A to signalling point B contain call identity CIB and are routed directly using destination point code PCB. Conversely, end-to-end messages transferred from signalling point B to signalling point A contain call identity CIA and are routed using destination point code PCA.

A linkage of call references at network boundaries has to be provided.

1.4.3.2 Coupling of connection sections

An ISDN user part end-to-end signalling connection may consist of a number of connection sections in tandem. In order to couple two connection sections at the SCCP relay point, linkage of call references, e.g. call as in Figure 2 (Ref. 3), is performed by ISDN user part for connectionless SCCP service and linkage of local references is performed by SCCP for connection-oriented SCCP service.

An SCCP relay point where linkage of call references is performed by the ISDN user part is called an "intermediate relay node" in this section.

1.4.3.3 Connectionless service (national use)

For connectionless service, the ISDN user part transfers the data to be transmitted to the SCCP together with a request for the appropriate protocol class of service. For call reference signalling information, transfer and delivery of this data to the distant ISDN user part is controlled entirely by the SCCP. The association between the transferred information and a call is made by the ISDN user part, which transfers the call reference as part of signalling information for this purpose.

The protocol class of service is assumed to be 0. Individual networks may choose class 1 based on the predetermined arrangement.

1.4.3.4 Connection-oriented service

1.4.3.4.1 Connection request embedded in an ISDN user part message

At the exchange initiating the establishment of an ISDN user part end-to-end signalling connection based on connection-oriented SCCP service, the ISDN user part requests the SCCP to provide the necessary information for a connection request for an SCCP end-to-end connection. This connection request is then carried embedded in an ISDN user part message. At the destination exchange the connection request is passed to the SCCP by the ISDN user part. The SCCP at the destination exchange then behaves as if the connection request had been sent directly by the SCCP from the originating exchange: it indicates the connection request to the ISDN user part and upon response from the ISDN user part it returns a connection confirm message to the SCCP at the originating exchange. The SCCP at the originating exchange confirms the set-up of the end-to-end connection to the ISDN user part. The contents in the embedded connection request is not evaluated by the ISDN user part at any exchange.

1.4.3.4.2 Protocol class of service

The protocol class of service is assumed to be 2. If the connection request is of protocol class 3, the ISDN user part connection request parameter must include explicit protocol class and credit indications in addition to the SCCP source local reference.

1.4.3.4.3 Mechanism of coupling

Although coupling of connection sections may not be appropriate in combination with the embedded method, coupling is necessary at network boundaries. In this case the ISDN user part at the intermediate point has knowledge that a coupling of end-to-end connection sections has to be performed, and therefore, connection requests received embedded in an ISDN user part message are passed to the SCCP. The SCCP, in turn, furnishes the ISDN user part with a connection request for the new connection section in order to have it included in the outgoing ISDN user part message.

After the coupling of the connection sections has been successfully initiated by the ISDN user part, end-to-end signalling information passing through an intermediate point is not passed to the ISDN user part.

1.4.3.4.4 Release of ISDN user part end-to-end signalling connection

The SCCP end-to-end connection is released according to the procedures described in Recommendation Q.714.

The physical connection and the ISDN user part end-to-end signalling connection can be released independently of each other.

Generally, both the ISDN user part end-to-end signalling connection and the physical connection are released simultaneously. However, for certain applications it is possible to maintain the SCCP end-to-end connection although the physical connection has already been released.

1.4.4 Chaining of ISDN user part end-to-end signalling connections

At an exchange where the contents of end-to-end signalling information may need to be evaluated by the ISDN user part, ISDN user part end-to-end signalling connections are chained. Chaining of two ISDN user part end-to-end signalling connections means that one ISDN user part end-to-end signalling connection terminates and another ISDN user part signalling connection associated with it originates with all end-to-end signalling information passing through the ISDN user part. The new ISDN user part signalling connection may have different characteristics from the previous one. See Figure 12.

If chaining is not appropriate for the associated call when the service requirements cannot be satisfied because of it, the call may be released. In addition, if any of the ISDN user part end-to-end signalling connections under chaining cannot be established or is abnormally disconnected, the associated call may be released if the required service cannot be completed without it.

1.4.5 Use of the protocol control indicator (PCI)

The protocol control indicator is control information concerning the end-to-end signalling procedures. It is contained in the Forward Call Indicators parameter and the Backward Call Indicators parameter respectively, and has to be examined to determine which end-to-end signalling method should be used if any for the end-to-end transfer of messages.

The indications given by the PCI are given in Recommendation Q.763.

1.4.6 Operation of the pass-along method (national use)

Figure 1 illustrates the operation of the pass-along protocol. In this figure the PCI is the protocol control indicator in the IAM.

1.4.7 Operation of the SCCP method – Connectionless services (national use)

1.4.7.1 Successful set-up of the ISDN user part end-to-end signalling connection

1.4.7.1.1 Simultaneous establishment of an ISDN user part end-to-end signalling connection and a physical connection

In the case of simultaneous establishment of a signalling connection with a physical connection, the initial address message from the originating exchange of a call contains the call reference consisting of the point code of the originating exchange and the call identity. The inclusion of the call reference implicitly indicates that the establishment of a signalling connection is requested. When the terminating exchange receives an IAM with a call reference, a signalling connection can be established. It then responds with its own call reference included in the first backward message (e.g. an address complete message).

At an intermediate relay node where SCCP is terminated, its own call reference is allocated to the signalling connection and the coupling of call references is made. When the first backward message contains a call reference, an intermediate relay node replaces that with its own call reference and relays this message towards the originating exchange.

When the originating exchange receives the destination call reference from the exchange at the other end of the connection section the signalling connection is regarded as in a ready state and end-to-end signalling information can be transferred over this connection.

a) PAMA between endpoints

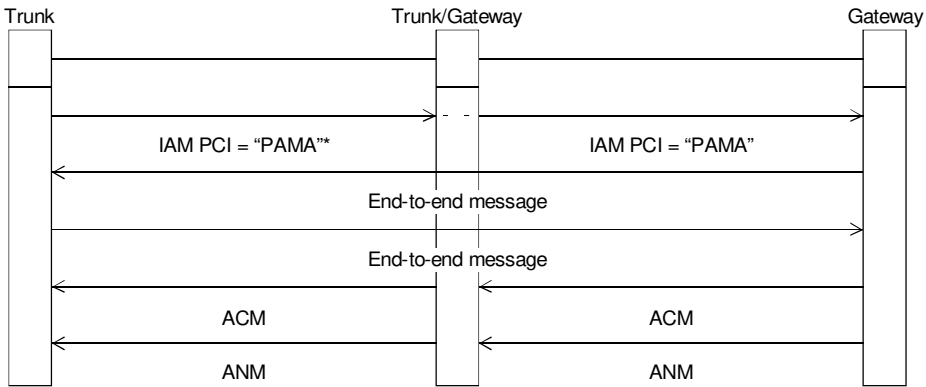

Either end is free to initiate further end-to-end interchanges subsequently.

b) PAMNA interworking towards destination

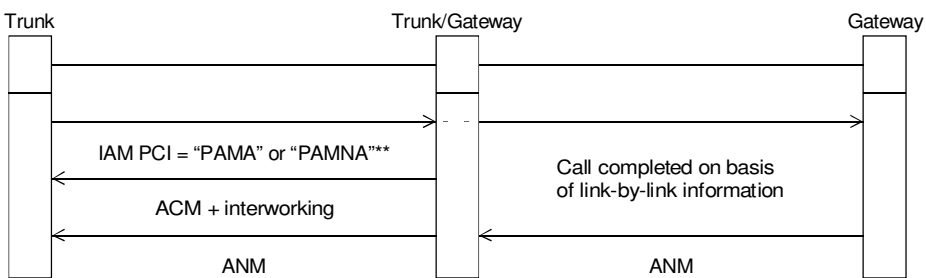

Origin informed that end-to-end interchange cannot be supported.

c) PAMNA interworking from origin

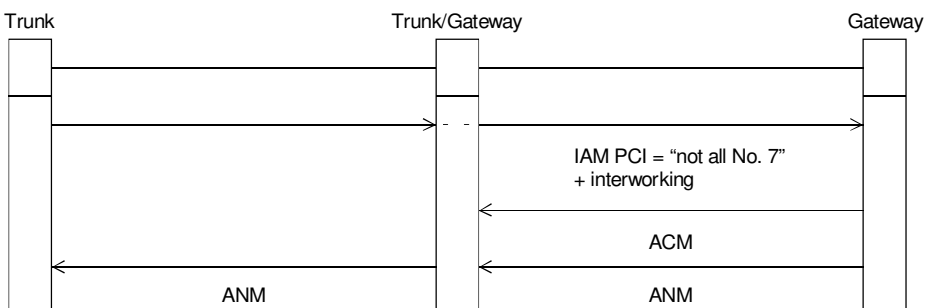

T1138940-91/d01

Destination informed that end-to-end interchange cannot be supported.

- * PAMA Pass-along method available.
- ** PAMNA Pass-along method not available.

FIGURE 1/Q.730
Operation of end-to-end protocol (pass-along method)

Figure 2 shows the procedure for this case.

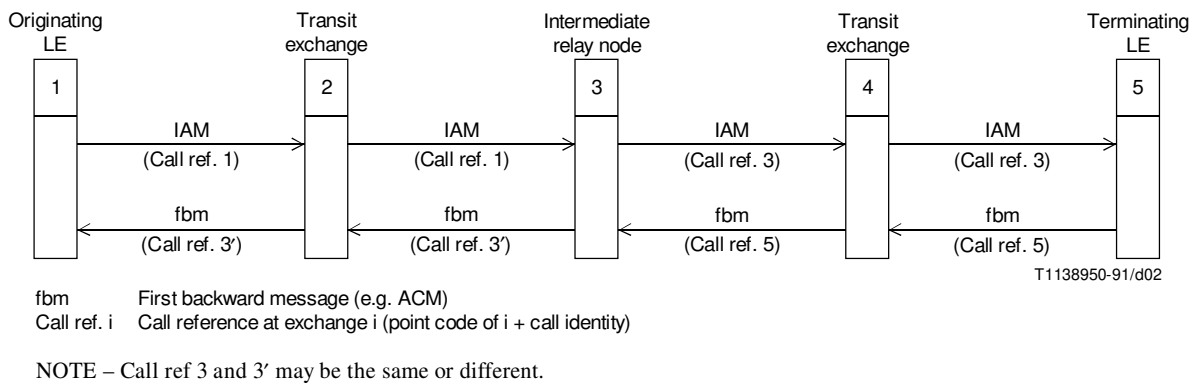

FIGURE 2/Q.730

Simultaneous establishment of a bearer connection and an ISDN user part end-to-end signalling connection, based on SCCP connectionless class

1.4.7.1.2 Establishment of a signalling connection when the circuit-associated signalling path has been established

When the circuit-associated signalling path has already been established, the establishment of a signalling connection can be initiated either by the originating or the terminating exchange of a call. In this case, an information request message (INR) is transferred from the initiating exchange to the other end. This INR message contains a call reference as in the case of an IAM as described in 1.4.7.1.1 above.

An information message (INF) containing a call reference as in the case of the first backward message in 1.4.7.1.1 is returned to the initiating exchange and a signalling connection is successfully established.

Figure 3 shows the procedure for this case.

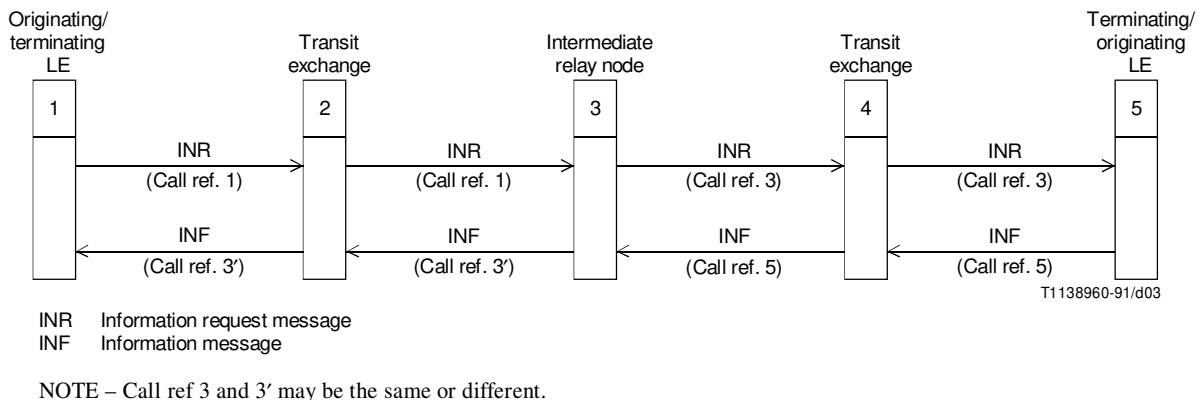

FIGURE 3/Q.730

Establishment of an ISDN signalling connection based on SCCP connectionless class, after the establishment of a circuit-associated signalling path

1.4.7.2 Unsuccessful set-up of a signalling connection

In a case where a signalling connection cannot be established, e.g. due to interworking with a PSTN, the first backward message in response to the initial address message containing the originating call reference includes no call reference.

The procedure for this case is shown in Figure 4.

In a case where the establishment for a signalling connection is requested by an INR message as shown in Figure 3, the initiating exchange usually knows the end-to-end signalling capability for the call concerned and a signalling connection can successfully be established. However, if a signalling connection cannot be established for some reason, an INF message containing no call reference is returned to the initiating exchange. In these situations, the call may be released if the ISDN user part end-to-end signalling connection is essential to satisfy the service requirements of the call.

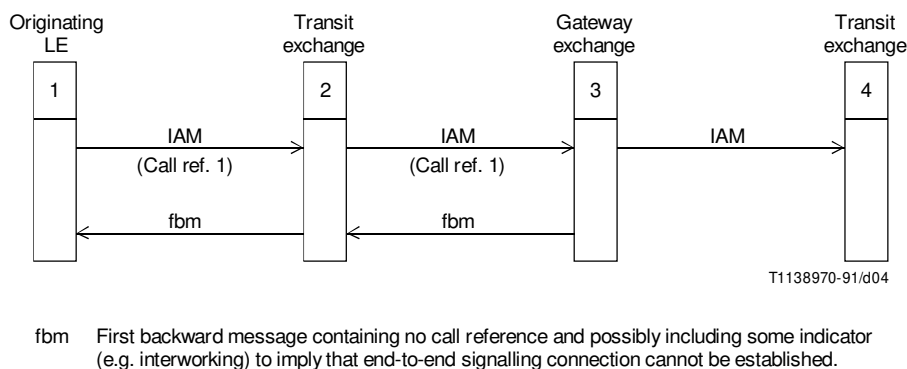

FIGURE 4/Q.730

Unsuccessful establishment of an ISDN user part end-to-end signalling connection, SCCP connectionless class, e.g. due to interworking with a PSTN

1.4.7.3 Abnormal situations

If no response to the INR message containing the originating call reference is received for the time T33 at the initiating exchange and if necessary (e.g. in the case of an interworking exchange of different end-to-end signalling schemes) at an intermediate relay node, the call is released (see 2.9.7/Q.764).

The procedure for this case is shown in Figure 5.

In this case, the call reference(s) is frozen for the time T31 as described in 1.4.7.4.2.

1.4.7.4 Release of a signalling connection

1.4.7.4.1 Simultaneous release of a physical connection and a signalling connection

When the call is released, the ISDN user part end-to-end signalling connection is considered to be released simultaneously. Call references allocated at local exchanges and intermediate relay node(s) are frozen for time T31 as described in 1.4.7.4.2 below.

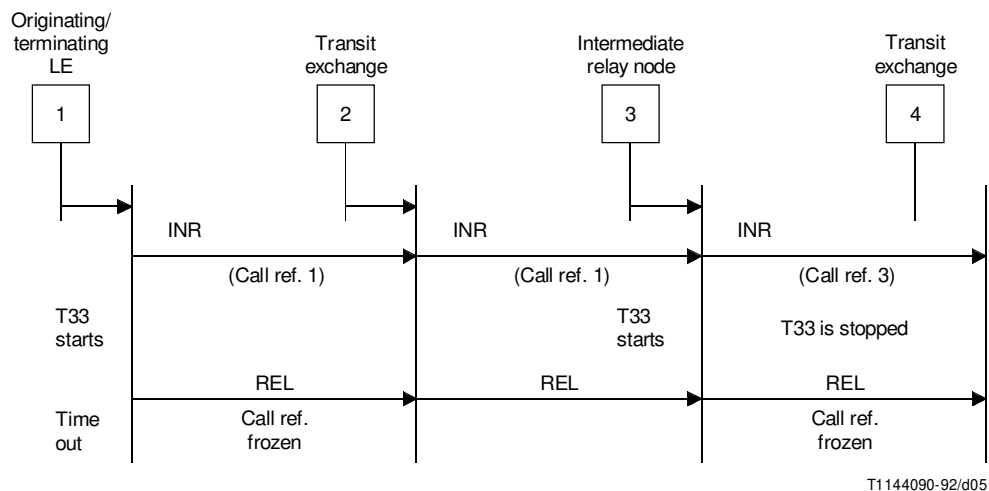

FIGURE 5/Q.730
No response from SCCP after time T33 after the transmission of the originating call reference, during the establishment of an ISDN user part end-to-end signalling connection based on SCCP connectionless class

The procedure for this case is shown in Figure 6.

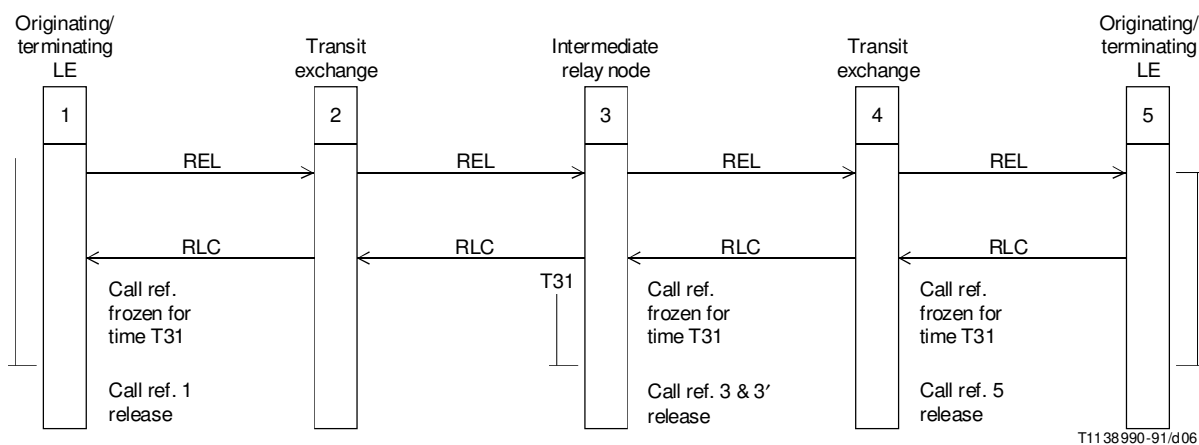

FIGURE 6/Q.730
Simultaneous release of a bearer connection and ISDN user part end-to-end signalling connection based on connectionless class

1.4.7.4.2 Frozen call reference

When an ISDN user part end-to-end signalling connection is released, call references allocated for this signalling connection are frozen for time T31. These references will not be used for another signalling connection during the frozen period. T31 is chosen to sufficiently reduce the probability of erroneously associating a message with the previously used call reference. Optionally call identities may be allocated to individual signalling connections in a cyclic manner so that a previously used call identity is not to be used again for a sufficient amount of time.

If an end-to-end message containing a frozen call reference is received, it is discarded.

1.4.7.5 End-to-end message transfer

An end-to-end message is transferred in an SCCP unit data (UDT) message according to the procedures defined in Recommendation Q.714. ISDN user part interfaces with SCCP via the primitives are defined in Recommendation Q.711 for this transfer. The UNIT-DATA request/indication primitive includes in its User Data parameter an ISDN user part message beginning with the message type and ending with the parameters.

At the local exchange which has responded to the request of establishment of an ISDN user part end-to-end signalling connection from the other local exchange, an end-to-end message cannot be transferred for time T32 or until the first end-to-end message has been received from the other end. T32 is chosen to sufficiently reduce the probability that an end-to-end message from the responding local exchange is received at the initiating local exchange or the intermediate relay node, before the ISDN user part message which contains the response to the signalling connection establishment request.

If a relay exchange receives an end-to-end message in a UDT, in any case the UDT will be forwarded to the succeeding exchange if possible.

The procedure for this case is shown in Figure 7.

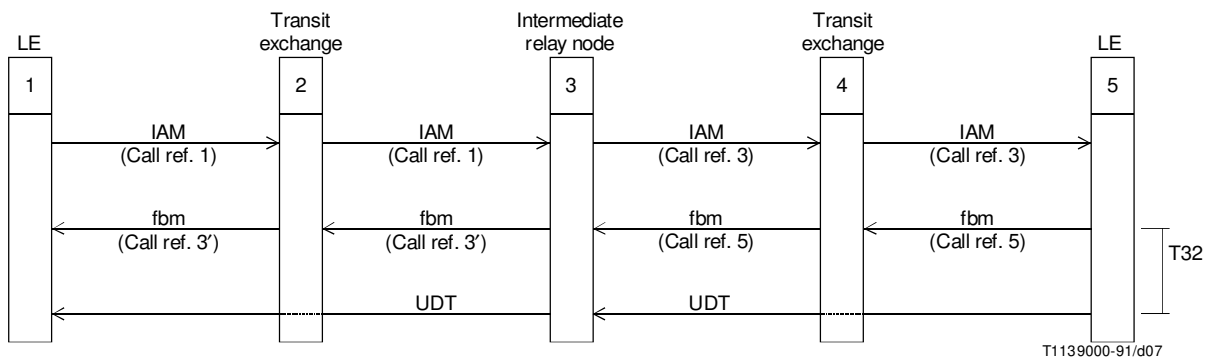

FIGURE 7/Q.730

Transfer of UDT message from the local exchange which has responded to the ISDN user part signalling connection establishment request

1.4.8 Operation of the SCCP method – Connection-oriented service

The initial address message, the facility request message and (as for national option) the information message may be used for the embedded transfer of the connection request. The procedures described and the figures refer to the case where the connection request is sent in the forward direction. In principle, they also apply when the connection request is sent in the backward direction in the facility request or (as for national option) the information message.

For the connection request embedded in an ISDN user part message an additional interface is used. This functional interface is described in Recommendations Q.711 and Q.714 (signalling connection control part of Signalling System No. 7). The interface elements are listed in 1.4.9.

Procedures concerning the SCCP are in accordance with those described in Recommendation Q.714 (signalling connection control part of Signalling System No. 7) and are described here only for illustrative purposes.

The SCCP may not be implemented at all international gateway exchanges. An embedded connection request will be handled as an unrecognized parameter at such an exchange and the information returned in the PCI shall indicate "no end-to-end method available (only link-by-link method available)". No further action is taken. This information is then evaluated by the exchange that has sent the information request (see 1.4.5).

1.4.8.1 Successful set-up of the ISDN user part end-to-end signalling connection

The following actions are performed at the originating exchange and at the destination exchange for the set-up of an SCCP end-to-end connection using embedded transfer of the connection request in an ISDN user part message (the numbers in the text correspond to the numbers in Figure 8):

- 1) The ISDN user part (ISUP) at the originating exchange requests the SCCP to provide the necessary information for a connection request to the called address using the REQUEST type 1 interface element.
- 2) The SCCP at the originating exchange generates a connection request and transfers it to the ISDN user part using the REPLY interface element.
- 3) The ISDN user part at the originating exchange transmits the connection request embedded in an ISDN user part message to the ISDN user part at the destination exchange.
- 7) Upon receiving an embedded connection request in an ISDN user part message, the ISDN user part at the destination exchange transmits the received connection request to the SCCP using the REQUEST type 2 interface element.
- 8) The SCCP at the destination exchange informs the ISDN user part of a request to establish an end-to-end connection using the N-CONNECT indication primitive.
- 9) The ISDN user part responds to the request using the N-CONNECT response primitive.
- 10) Upon receiving the N-CONNECT response primitive from the ISDN user part, the SCCP at the destination exchange sends a connection confirm message into the backward direction.
- 12) Upon receiving a connection confirm message the SCCP at the originating exchange informs the ISDN user part using the N-CONNECT confirmation primitive.

At those transit exchanges which are not SCCP relay points, the connection request embedded in an ISDN user part message is left unchanged by the ISDN user part and transferred into the forward direction.

An SCCP relay point is an exchange where two connection sections belonging to the same end-to-end connection are coupled.

The following actions are performed at an SCCP relay point for the coupling of two connection sections (the numbers in the text correspond to the numbers in Figure 8):

- 4) Upon receiving an embedded connection request in an ISDN user part (ISUP) message, the ISDN user part at the SCCP relay point transfers the received connection request to the SCCP using the REQUEST type 2 interface element with the reply request set.
- 5) The reply request in the REQUEST type 2 interface element causes the SCCP at the SCCP relay point to provide a connection request for a new connection section. The new connection request is provided to the ISDN user part using the REPLY interface element.

NOTE – The SCCP allocates an outgoing local reference and associates the incoming and outgoing local references and their corresponding point codes.

- 6) The ISDN user part at the SCCP relay point transmits the connection request embedded in an ISDN user part message.
- 11) Upon receiving a connection confirm message, the SCCP at the SCCP relay point sends a connection confirm message into the backward direction.

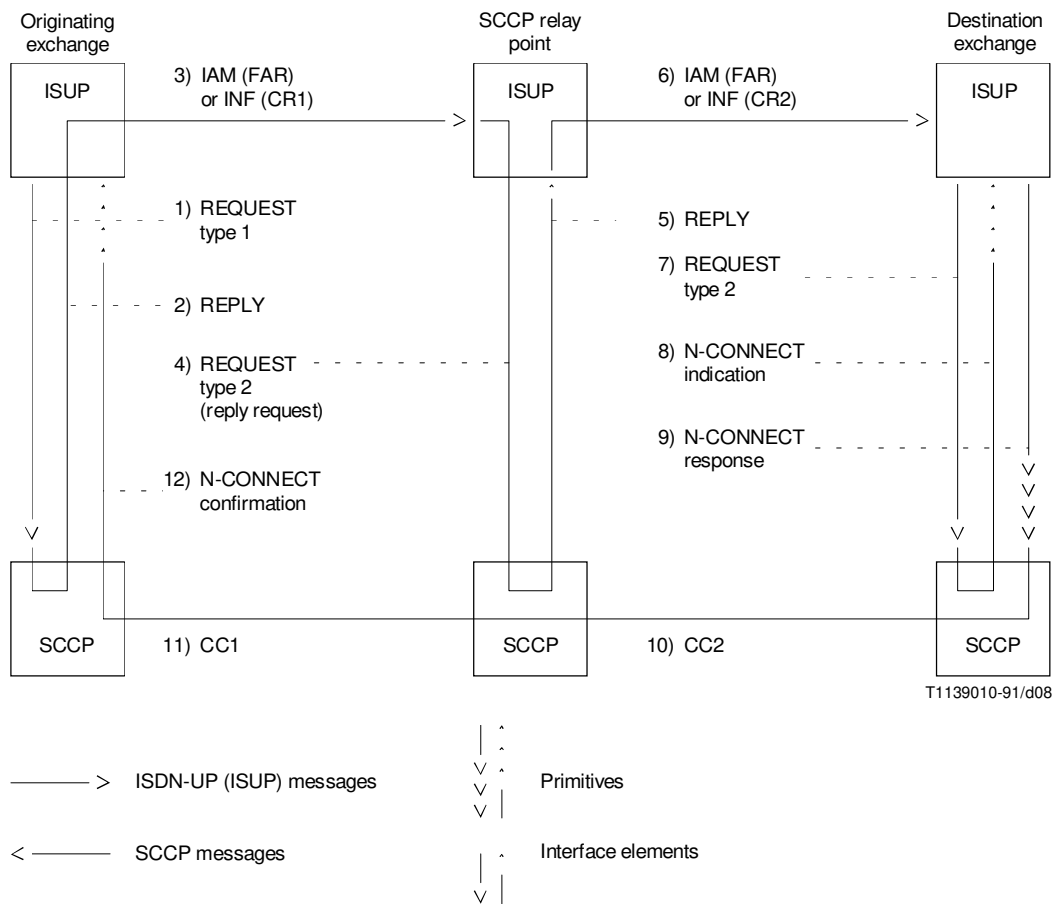

FIGURE 8/Q.730

Embedded transfer of the connection request actions under successful set-up of the SCCP end-to-end connection

1.4.8.2 Unsuccessful set-up of the SCCP end-to-end connection

If the ISDN user part end-to-end signalling connection cannot be extended beyond a transit exchange because (for instance) interworking occurs, the ISDN user part at this transit exchange initiates the refusal of the connection request which is then performed by the SCCP. The set-up of the physical connection may be continued.

If the ISDN user part initiates the refusal of a connection request received embedded in the initial address message, in general the following actions are performed. The numbers in the text correspond to the numbers in Figure 9:

- 1) Upon receiving an embedded connection request, the ISDN user part transfers the received connection request to the SCCP using the REQUEST type 2 interface element with the refusal indicator set.
- 2) Upon receiving the REQUEST type 2 interface element with the refusal indicator set, the SCCP sends a connection refused message (CREF) into the backward direction.
- 3) Upon receiving a connection refused message, the SCCP at the originating exchange informs the ISDN user part using the N-DISCONNECT indication primitive.

If the SCCP at an SCCP relay point receives a connection refused message instead of a connection confirm message, the incoming connection section is also released by sending a connection refused message into the backward direction.

If the SCCP at the destination exchange fails to set up the requested end-to-end connection, the following actions are performed to refuse the connection request received in a REQUEST type 2 interface element (the numbers in the text correspond to the numbers in Figure 10):

- 1) The SCCP at the destination exchange sends an N-DISCONNECT indication primitive to the ISDN user part.
- 2) At the same time the SCCP sends a connection refused message into the backward direction. In these situations, the call may be released if the ISDN user part end-to-end signalling connection is essential to satisfy the service requirements of the call.

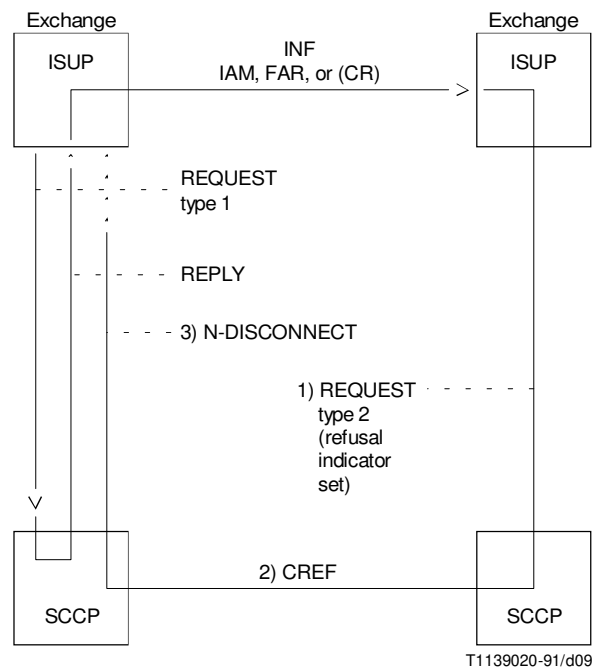

FIGURE 9/Q.730

Embedded transfer of the connection request and refusal of the connection request initiated by the ISDN user part

1.4.8.3 Unsuccessful set-up of the physical connection

If the physical connection cannot be set up at a transit exchange, in addition to releasing the physical connection so far established, the ISDN user part initiates the refusal of the connection request. The same actions are performed as at a transit exchange beyond which a logical connection cannot be extended.

If the physical connection cannot be set up at the destination exchange, the ISDN user part can initiate either the refusal or the confirmation of the connection request depending on supplementary services. It may be preferred to always confirm the connection request to allow for the initiation of supplementary services by the calling subscriber.

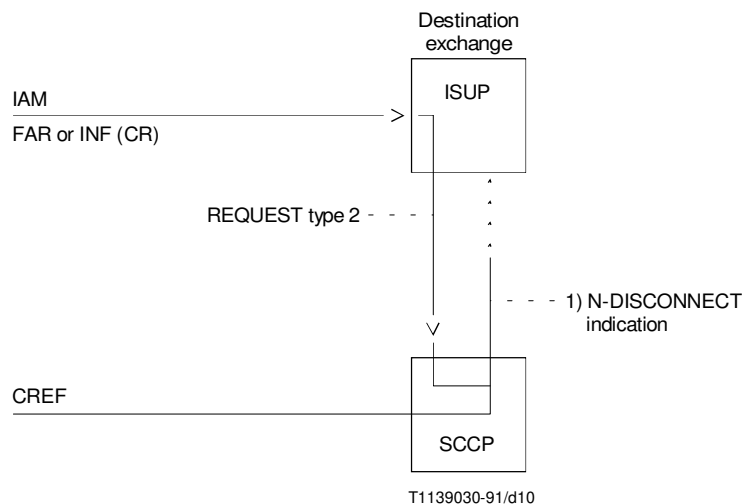

FIGURE 10/Q.730

Embedded transfer of the connection request failure of the SCCP at the destination exchange in setting up the requested end-to-end connect

1.4.8.4 Release of the ISDN user part (ISUP) end-to-end signalling connection

1.4.8.4.1 Simultaneous release of the physical and ISUP signalling connections

The release of the ISDN user part end-to-end signalling connection is initiated from the exchange which initiates the release of the call concerned. At the initiating exchange of call release, when the ISDN user part release message (REL) is transmitted, ISDN user part requests SCCP to transmit a released message (RLSD). This RLSD message contains a cause value of "end user originated" in its cause parameter, if a normal call release initiated by a user is taking place.

Figure 11 shows the procedure for this case.

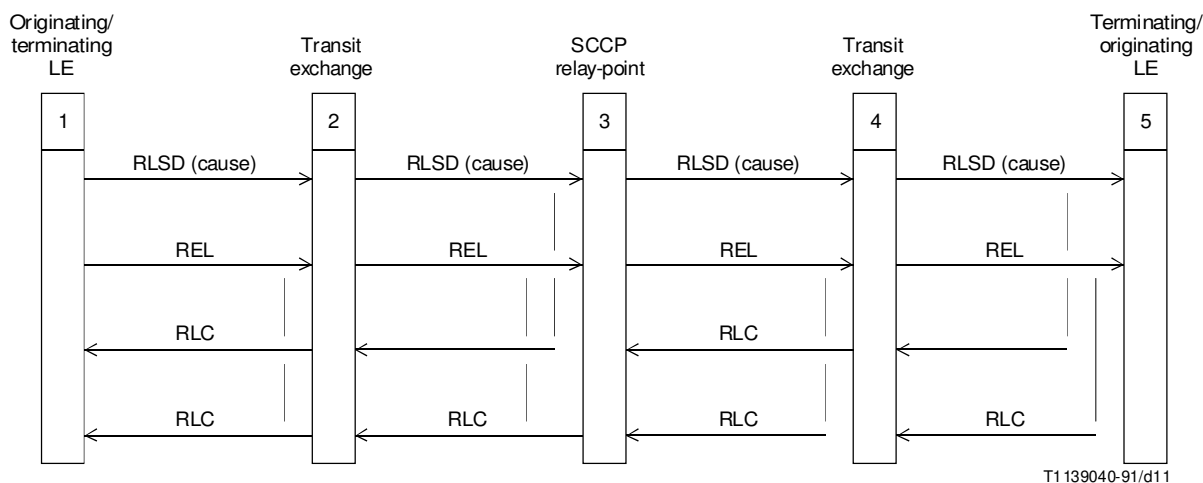

T1 139040-91/d11

FIGURE 11/Q.730

Simultaneous release of a bearer connection and an ISDN user part end-to-end signalling connection based on SCCP connection oriented class

In the case where no application requires the ISDN user part end-to-end signalling connection to be maintained, the ISDN user part at a local exchange, or an exchange performing chaining, requests the SCCP to release the SCCP end-to-end connection if it receives a release message (REL) and the SCCP has not yet received a released (RLSD) message at that time (see Figure 12).

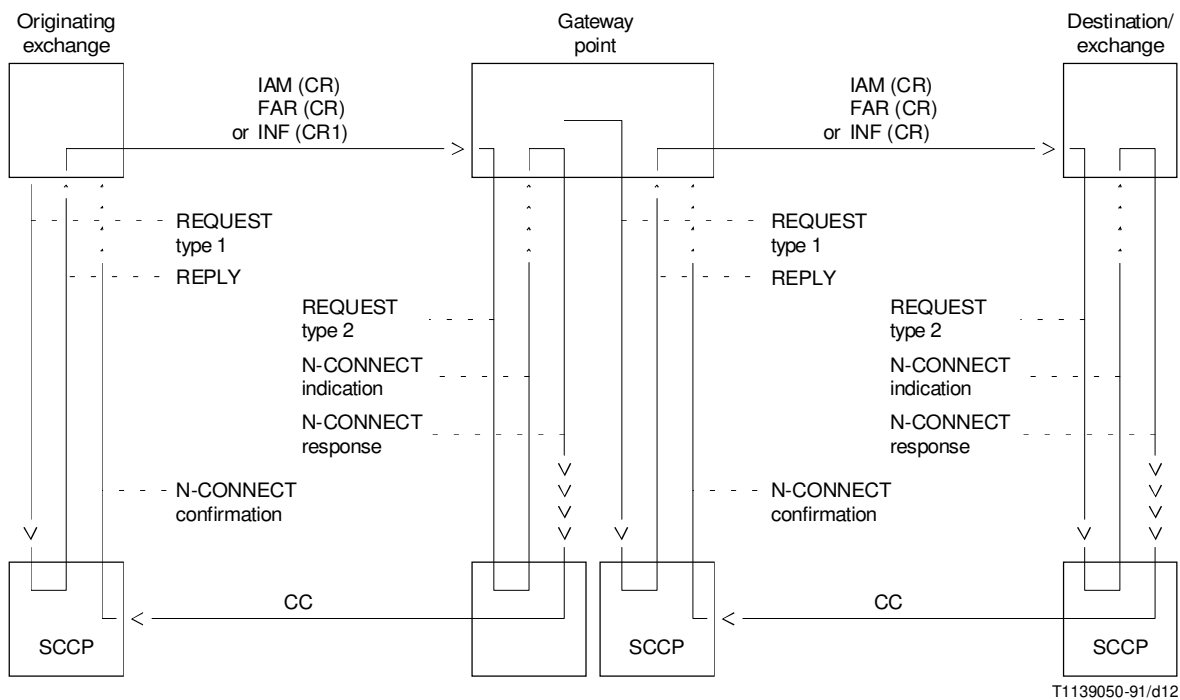

T1139050-91/d12

FIGURE 12/Q.730
Chaining of end-to-end connections
 (the outgoing end-to-end connection is assumed to be of the same type as the incoming end-to-end connection)

1.4.8.4.2 Non-simultaneous release of the physical and the ISDN user part end-to-end signalling connections

Procedures for non-simultaneous release of the physical and the ISDN user part end-to-end signalling connections are to be defined in appropriate supplementary service procedures.

1.4.8.5 End-to-end message transfer

An end-to-end message is transferred in an SCCP data (DT1/DT2) message according to the procedures defined in Recommendation Q.714. ISDN user part interfaces with SCCP via the primitives as defined in Recommendation Q.711 for this transfer. The data request/indication primitive includes in its user data parameter an ISDN user part message beginning with the message type code and ending with the parameters.

1.4.9 Interface elements between ISDN user part and SCCP (embedded transfer)

The ISDN user part may use the functional interface as defined in Recommendation Q.711. Three interface elements are defined for this functional interface:

- a) the REQUEST type 1
- b) the REQUEST type 2
- c) the REPLY

The contents of these three interface elements is shown in Appendix I.

Figures 8, 9 and 11 indicate the usage of the interface elements during the set-up of a circuit-switched connection together with an SCCP connection.

1.5 Layout of service Recommendations

The agreed format for each supplementary service is indicated below:

- 1 Definition
- 2 Description
 - 2.1 General description
 - 2.2 Specific terminology
 - 2.3 Qualification on the applicability to telecommunication services
 - 2.4 State definitions
3. Operational requirements
 - 3.1 Provision/withdrawal
 - 3.2 Requirements on the originating network side
 - 3.3 Requirements in the network
 - 3.4 Requirements on the terminating network side
- 4 Coding requirements
- 5 Signalling requirements
 - 5.1 Activation/deactivation/registration
 - 5.2 Invocation and operation
 - 5.2.1 Actions at the originating local exchange
 - 5.2.1.1 Normal operation
 - 5.2.1.2 Exceptional procedures
 - 5.2.2 Actions at the transit exchange
 - 5.2.2.1 Normal operation
 - 5.2.2.2 Exceptional procedures
 - 5.2.3 Actions at the outgoing international gateway exchange
 - 5.2.3.1 Normal operation
 - 5.2.3.2 Exceptional procedures
 - 5.2.4 Actions at the incoming international gateway exchange
 - 5.2.4.1 Normal operation
 - 5.2.4.2 Exceptional procedures
 - 5.2.5 Actions at the destination local exchange
 - 5.2.5.1 Normal operation
 - 5.2.5.2 Exceptional procedures
- 6 Interaction with other supplementary services
 - 6.1 Call Waiting (CW)
 - 6.2 Call transfer services (for further study)
 - 6.3 Connected Line Identification Presentation (COLP)
 - 6.4 Connected Line Identification Restriction (COLR)
 - 6.5 Calling Line Identification Presentation (CLIP)
 - 6.6 Calling Line Identification Restriction (CLIR)
 - 6.7 Closed user Group (CUG)
 - 6.8 Conference Calling (CONF)

- 6.9 Direct-Dialling-In (DDI)
- 6.10 Call Diversion Services (CDIV)
- 6.10.1 Call Forwarding Busy (CFB)
- 6.10.2 Call Forwarding No Reply (CFNR)
- 6.10.3 Call Forwarding Unconditional (CFU)
- 6.10.4 Call Deflection (CD)
- 6.11 Line Hunting (LH)
- 6.12 Three-Party Service (3PTY)
- 6.13 User-to-User Signalling (UUS)
- 6.13.1 User-to-User Signalling, service 1 (UUS1)
- 6.13.2 User-to-User Signalling, service 2 (UUS2)
- 6.13.3 User-to-User Signalling, service 3 (UUS3)
- 6.14 Multiple Subscriber Number (MSN)
- 6.15 Call Hold (HOLD)
- 6.16 Advice of Charge (AOC)
- 6.17 Sub-addressing (SUB)
- 6.18 Terminal Portability (TP)
- 6.19 Completion of Calls to Busy Subscriber (CCBS) (for further study)
NOTE – Some information on the CCBS service currently exists within Recommendation Q.763
- 6.20 Malicious Call Identification (MCID)
- 6.21 Reverse charging (REV) (for national use)
- 6.22 Multi-Level precedence and Preemption (MLPP)
- 6.23 Private Numbering Plan (PNP) (for further study)
- 6.24 International Telecommunication Charge Card (for further study)
- 7 Interaction with other networks
- 8 Signalling flows
- 9 Parameter values (timers)
- 10 Dynamic description

1.6 List of supplementary services

The following set of supplementary services is currently identified and more may be identified in the future:

Recommendation Q.731

NUMBER IDENTIFICATION SUPPLEMENTARY SERVICES

- Q.731.1 Direct-Dialling-In (DDI)
- Q.731.2 Multiple Subscriber-Number (MSN)
- Q.731.3 Calling Line Identification Presentation (CLIP)
- Q.731.4 Calling Line Identification Restriction (CLIR)
- Q.731.5 Connected Line Identification Presentation (COLP)
- Q.731.6 Connected Line Identification Restriction (COLR)
- Q.731.7 Malicious Call Identification (MCID)
- Q.731.8 Sub-addressing (SUB)

Recommendation Q.732

CALL OFFERING SUPPLEMENTARY SERVICES

- Q.732.1 Call Transfer (CT)
- Q.732.2 Call Forwarding Busy (CFB)
- Q.732.3 Call Forwarding No Reply (CFNR)
- Q.732.4 Call Forwarding Unconditional (CFU)
- Q.732.5 Call Deflection (CD)
- Q.732.6 Line Hunting (LH)
- Q.732.7 Explicit Call Transfer (ECT)
- Q.732.8 Single Step Call Transfer (SCT)

Recommendation Q.733

CALL COMPLETION SUPPLEMENTARY SERVICES

- Q.733.1 Call Waiting (CW)
- Q.733.2 Call Hold (HOLD)
- Q.733.3 Completion of Calls to Busy Subscribers (CCBS)
- Q.733.4 Terminal Portability (TP)

Recommendation Q.734

MULTIPARTY SUPPLEMENTARY SERVICES

- Q.734.1 Conference Calling (CONF)
- Q.734.2 Three-Party Service (3PTY)

Recommendation Q.735

COMMUNITY OF INTEREST SUPPLEMENTARY SERVICES

- Q.735.1 Closed User Group (CUG)
- Q.735.2 Private Numbering Plan (PNP)
- Q.735.3 Multi-Level Precedence and Preemption (MLPP)

Recommendation Q.736

CHARGING SUPPLEMENTARY SERVICES

Q.736.1 International Telecommunication Charge Card

Q.736.2 Advice of Charge (AOC)

Q.736.3 Reverse Charge (REV)

Recommendation Q.737

ADDITIONAL INFORMATION TRANSFER SUPPLEMENTARY SERVICE

Q.737.1 User-to-User Signalling (UUS)

1.7 Association of supplementary services to bearer services and teleservices

See 3/I.250.

1.8 Definition of supplementary services

See 4/I.250.

Appendix I

Contents of the interface elements between the ISDN user part and the SCCP

(This appendix does not form an integral part of this Recommendation)

These interface elements are defined in SCCP Recommendations (Q.711 to Q.716) and are included here for information.

I.1 Contents of the REQUEST type 1

The REQUEST type 1 interface element may contain the following parameters:

- connection identification (for further study);
- receipt confirmation selection;
- expedited data selection;
- quality of service parameter set.

I.2 Contents of the REQUEST type 2

The REQUEST type 2 interface element may contain the following parameters:

- network indicator (for further study);
- protocol class;
- credit;
- connection identification (for further study);
- source local reference;
- originating signalling point code;
- reply request;
- refusal indicator.

I.3 Contents of the REPLY

The REPLY interface element may contain the following parameters:

- source local reference;
- protocol class;
- credit;
- connection identification (for further study).