



INTERNATIONAL TELECOMMUNICATION UNION

ITU-T

TELECOMMUNICATION
STANDARDIZATION SECTOR
OF ITU

Q.72

(03/93)

**GENERAL RECOMMENDATIONS ON TELEPHONE
SWITCHING AND SIGNALLING
FUNCTIONS AND INFORMATION FLOWS
FOR SERVICES IN THE ISDN**

**STAGE 2 DESCRIPTION FOR
PACKET MODE**

ITU-T Recommendation Q.72

(Previously "CCITT Recommendation")

FOREWORD

The ITU Telecommunication Standardization Sector (ITU-T) is a permanent organ of the International Telecommunication Union. The ITU-T is responsible for studying technical, operating and tariff questions and issuing Recommendations on them with a view to standardizing telecommunications on a worldwide basis.

The World Telecommunication Standardization Conference (WTSC), which meets every four years, established the topics for study by the ITU-T Study Groups which, in their turn, produce Recommendations on these topics.

ITU-T Recommendation Q.72 was prepared by the ITU-T Study Group XI (1988-1993) and was approved by the WTSC (Helsinki, March 1-12, 1993).

NOTES

1 As a consequence of a reform process within the International Telecommunication Union (ITU), the CCITT ceased to exist as of 28 February 1993. In its place, the ITU Telecommunication Standardization Sector (ITU-T) was created as of 1 March 1993. Similarly, in this reform process, the CCIR and the IFRB have been replaced by the Radiocommunication Sector.

In order not to delay publication of this Recommendation, no change has been made in the text to references containing the acronyms "CCITT, CCIR or IFRB" or their associated entities such as Plenary Assembly, Secretariat, etc. Future editions of this Recommendation will contain the proper terminology related to the new ITU structure.

2 In this Recommendation, the expression "Administration" is used for conciseness to indicate both a telecommunication administration and a recognized operating agency.

© ITU 1994

All rights reserved. No part of this publication may be reproduced or utilized in any form or by any means, electronic or mechanical, including photocopying and microfilm, without permission in writing from the ITU.

CONTENTS

	<i>Page</i>
0 General	1
1 X.25 virtual call and permanent virtual circuit bearer service.....	1
1.1 Scope	1
1.2 References	1
1.3 Definitions.....	2
1.4 Symbols and abbreviations.....	2
1.5 Description (I.232.1).....	2
1.6 Derivation of the functional model.....	2
1.7 Information flows.....	4
1.8 SDL diagrams for functional entities	19
1.9 Functional entity actions (FEAs)	19
1.10 Allocation of functions to physical entities	23
2 Frame mode virtual call and permanent virtual circuit bearer services.....	23
2.1 Scope	23
2.2 References	25
2.3 Definitions.....	25
2.4 Symbols and abbreviations.....	25
2.5 Description	26
2.6 Derivation of the functional model.....	27
2.7 Information flows.....	28
2.8 SDL diagrams for functional entities	32
2.9 Functional entity actions (FEAs)	32
2.10 Allocation of functions to physical entities	35

SUMMARY

This Recommendation provides the stage 2 descriptions for call set-up and release applicable to the packet mode virtual call services supported by an ISDN. The stage 2 descriptions are comprised of the switching functions and signalling information flows. Stage 2, which is defined in detail in Recommendation Q.65, is part of the three stage service description methodology described in Recommendation I.130.

Recommendation Q.72 describes virtual call services which provide the unrestricted bi-directional transfer of user information in a packetized manner over a virtual circuit within a B- or D-channel from one S/T reference point to another. The user information consists of layer 2 frames consistent with the layer 2 definitions of DSS 1. The data units are routed through the network on the basis of an attached label. This label is a logical identifier with local significance.

STAGE 2 DESCRIPTION FOR PACKET MODE

(Helsinki, 1993)

0 General

The purpose of this Recommendation is to provide information on the functions in ISDN entities and the information flows between the entities which are required to provide call control and data transfer procedures for packet mode services on the ISDN.

Currently, only the ISDN virtual call and permanent virtual circuit bearer services are defined (see Recommendations I.232.1 and X.31).

The following services have been identified and may be added to this Recommendation at a later date:

- connectionless bearer service (see Recommendation I.232.2);
- user signalling bearer service (see Recommendation I.232.3);
- additional packet-mode bearer services (the framework for these services are described in Recommendation I.122).

1 X.25 virtual call and permanent virtual circuit bearer service

1.1 Scope

This Recommendation provides the stage 2 descriptions for call set-up, call release and data transfer applicable to the X.25 virtual call service and the permanent virtual circuit service supported by an ISDN. Note that permanent virtual circuit service has no call set-up and release procedures.

For ISDN virtual call and PVC bearer services, the emphasis is placed on the access arrangements to packet switching functions provided by an ISDN or PSPDN, and not on the inter-packet-switch functions. However, future service descriptions may include details of the functional entities and information flows throughout an ISDN.

This Recommendation is based on the methodology specified in Recommendation Q.65 [3].

This Recommendation is applicable to the stage 3 standards for the ISDN packet-mode service. The term “stage 3” is also defined in Recommendation I.130 [1].

1.2 References

The references are cited at the appropriate places in the text and the publications are listed hereafter. For data references, subsequent amendments to, or revisions of, any of these publications apply to this Recommendation only when incorporated in it by amendment or revision. For undated references, the latest edition of the publication referred to applies.

- [1] CCITT Recommendation I.130 (1988) *Method for the characterization of telecommunication services supported by an ISDN and network capabilities of an ISDN.*
- [2] CCITT Recommendation I.112 (1988) *Vocabulary of terms for ISDNs.*
- [3] CCITT Recommendation Q.65 (1988) *Stage 2 of the method for the characterization of services supported by an ISDN.*
- [4] CCITT Recommendation I.232.1 (1988) *Virtual call and permanent virtual circuit bearer service category.*

- [5] CCITT Recommendation Q.71 (1988) *ISDN 64 kbits circuit-mode switched bearer service.*
- [6] CCITT Recommendation I.210 (1988) *Principles of telecommunication services supported by an ISDN and the means used to describe them.*
- [7] CCITT Recommendation I.462 (1988) *Support of packet mode terminal equipment by an ISDN.*
- [8] CCITT Recommendation X.31 *Support of packet-mode terminal equipment by an ISDN.*

1.3 Definitions

For the purposes of this Recommendation, the following definitions apply:

integrated services digital network (ISDN): See 2.3/I.112 [2], definition 308.

service: bearer service: See 2.2/I.112 [2], definition 202.

virtual call: See Recommendation I.232.1 [4].

permanent virtual circuit: See Recommendation I.232.1 [4].

1.4 Symbols and abbreviations

AU	Access Unit
DAS	Disconnect Access Situation
FEA	Functional Entity Action
ISDN	Integrated Services Digital Network
LE	Local Exchange
NT2	Network Termination type 2
OAS	Originating Access Situation
OR	Originating
TAS	Terminating Access Situation
TE	Terminating
VC	Virtual Call

1.5 Description (I.232.1)

This bearer service category provides the unrestricted transfer (without alteration) of user information in a packetized manner over a virtual circuit within a B- or D-channel at the S/T reference point. Signalling information for virtual call and/or possibly OAM information for permanent virtual circuit services are/is transferred via B- or D-channel as described in Recommendation I.462 [7] (see Recommendation X.31 [8]).

1.6 Derivation of the functional model

The full functional model would be an end-to-end representation of the functions in a virtual call. The functional model in Figure 1-1 represents only the access portion of the full model because the information flows for internal ISDN or PSPDN links are not covered by this Recommendation. The model is a basis for representing the functional entities and information flows for a packet-mode call or data transfer, originated by a user interacting with FE1 and terminating to a user interacting with FE6. FE6 may transfer data to FE1 while the connection is established. The functional model accommodates several access situations (AS), as described below. For each access situation, only a subset of the FEs and relationship types may be employed. Each AS may have an information flow diagram.

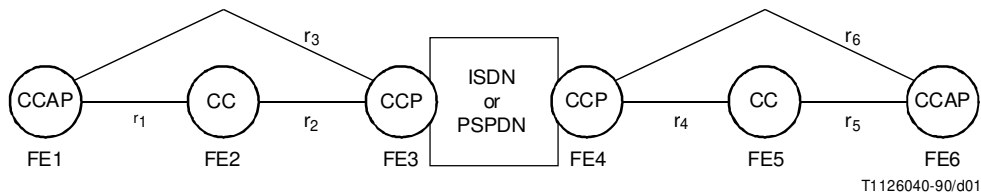

FIGURE 1-1/Q.72
Functional model

The CCAP is a functional entity that serves users, that initiates functional requests and interacts with CCs or CCPs. CCs and CCAPs are functional entities that cooperate with each other to provide the services requested by the CCAPs; r_1 through r_6 are types of relationships between functional entities wherein information flows occur, in order to process call attempts or service requests. See 1.6.1, 1.6.2 and 1.6.3 below.

The functional model addresses only the functional entity actions and information flows at the network layer of the Open System Interconnect model. It is assumed that link layer functions exist which provide the necessary communication channels. The term “network layer” refers to information flows which result in Q.931 messages or X.25 packet layer messages.

1.6.1 Description of the packet call control agent (CCAP) functional entity

FE1 and FE6 represent the originating and terminating CCAP functions which

- a) access the ISDN service-providing capabilities of the CC entities, using service requests for the establishment, manipulation and release of access channel connections for a single call;
- b) establish, manipulate and release virtual calls over the established access channels;
- c) receive information relating to the ISDN call or use of facilities from the CC entity and relay them to the user;
- d) maintain ISDN call state information as perceived from this functional end-point of the service (i.e. a single ended view of the ISDN virtual call).

1.6.2 Description of the call control (CC) functional entity

The CC functional entity supports the functionality to

- a) establish, manipulate and release switched access to a packet handler capability or use of facilities (upon request of the CCA entity);
- b) associate and relate the CCAP entities that are involved in access for a particular call and/or service;
- c) manage the relationship between the CCAP entities involved in an ISDN call or use of facilities (i.e. reconcile and maintain the overall perspective of the call and/or service).

NOTE – The CC functional entity does not support packet handling functions.

1.6.3 Description of the call control packet handler (CCP) functional entity

The CCP functional entity supports the functionality to

- a) establish, manipulate and release switched access to an integral ISDN packet-handling capability;
- b) establish, manipulate and release virtual calls over established access channels;
- c) associate and relate the CCAP entities that are involved in a particular virtual call;
- d) manage the relationship between the CCAP entities involved in a virtual call (i.e. reconcile and maintain the overall perspective of the virtual call).

1.7 Information flows

1.7.1 Information flow diagrams for call set-up and release

The information flow diagrams for call set-up and release for a virtual call within an ISDN or to a packet switched public data network are shown in Figures 1-2 to 1-11.

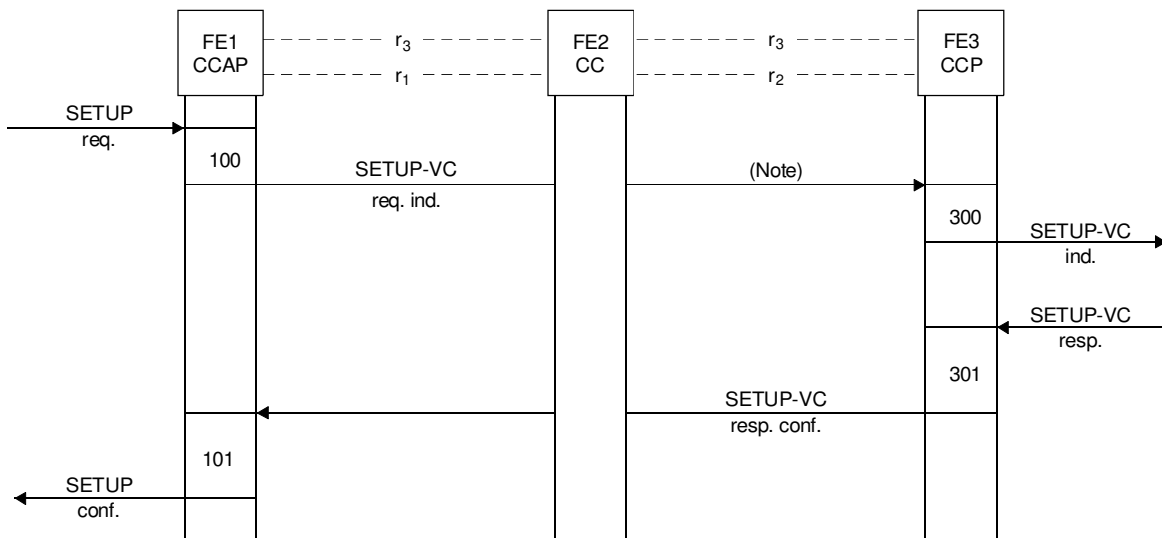

T1133990-91/d02

NOTE – The absence of line across an FE indicates no involvement of the FE.

FIGURE 1-2/Q.72
Originating access situation, access channel established (OAS1)

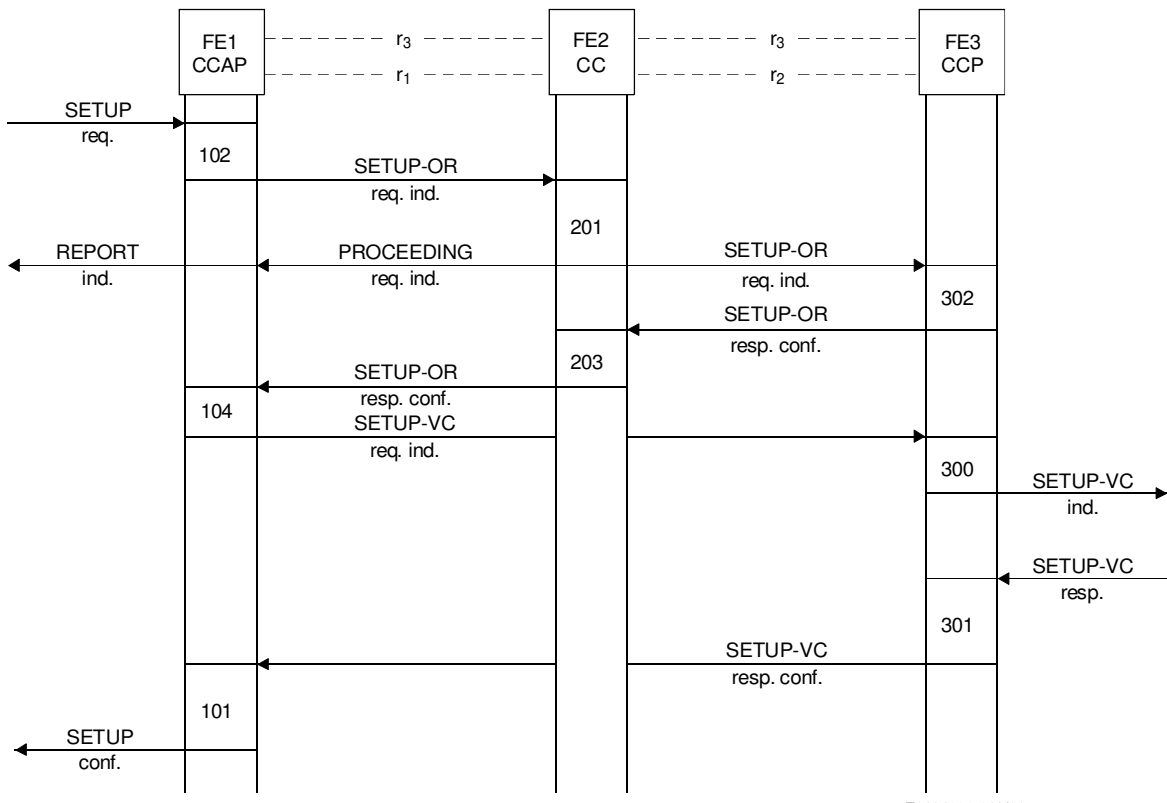

FIGURE 1-3/Q.72
Originating access situation, B-channel required (OAS2)

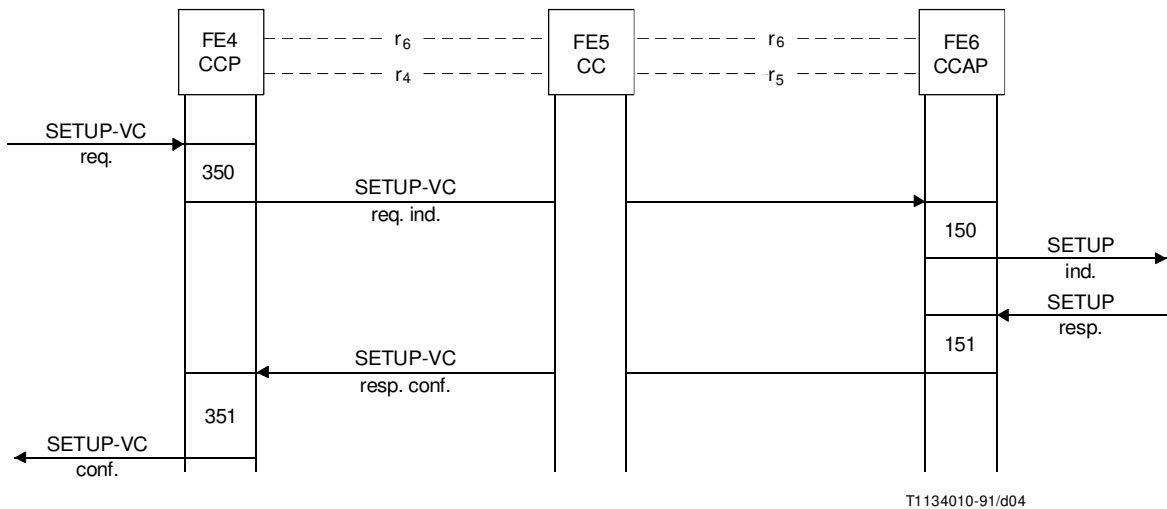

FIGURE 1-4/Q.72
**Terminating access situation, access channel established and selected,
 no notification (TAS1) or conditional notification (TAS2)**

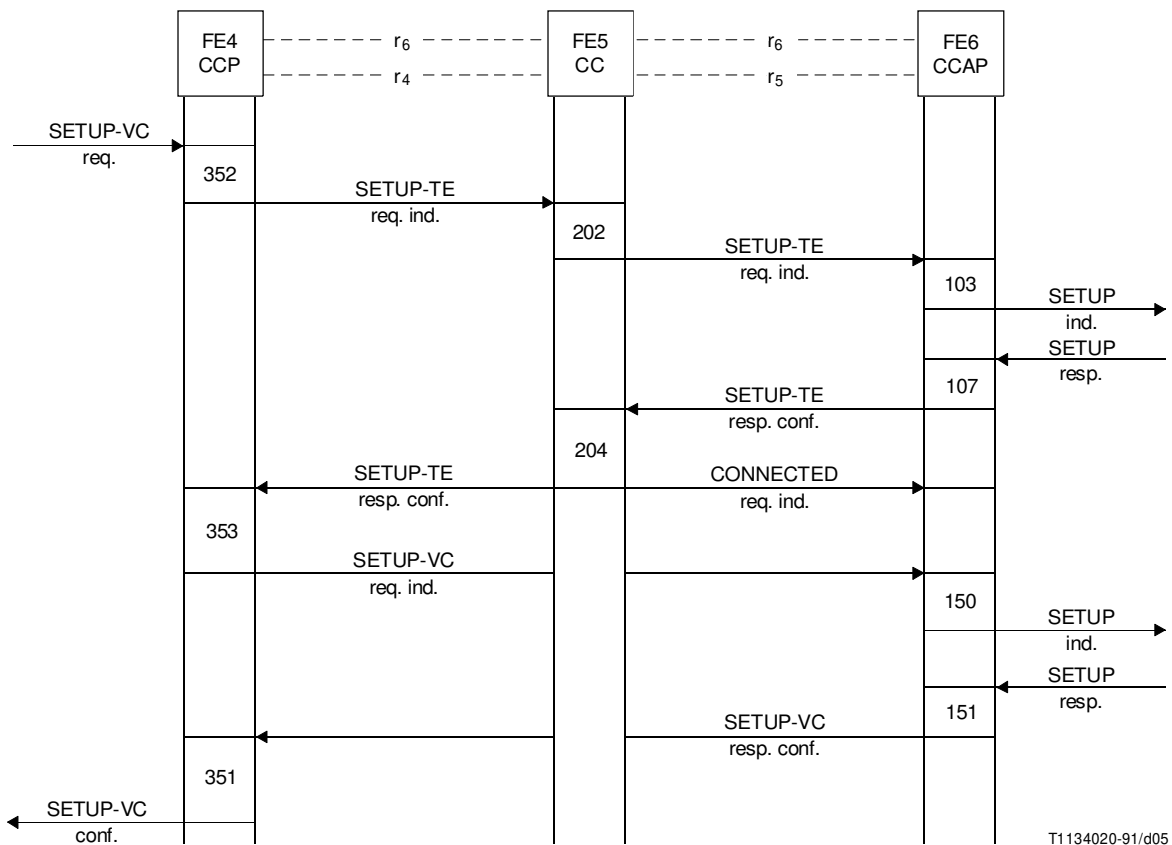
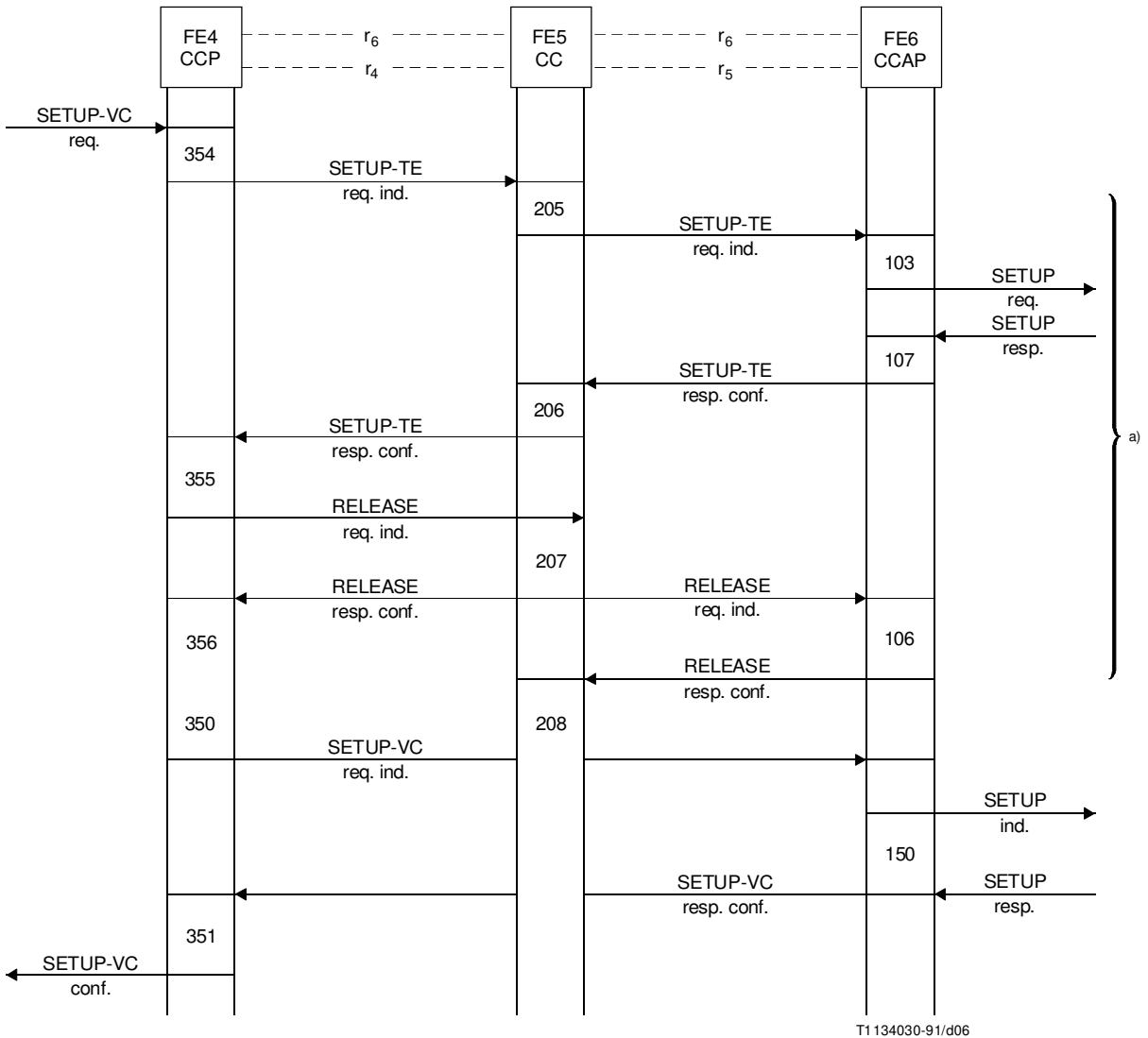

FIGURE 1-5/Q.72

Terminating access situation, no access channel established, or established channel not selected conditional notification (TAS2) or unconditional notification (TAS3)



a) These information flows are for user notification and are not associated with any established channel.

FIGURE 1-6/Q.72
**Terminating access situation, access channel established
 and selected, unconditional notification (TAS3)**

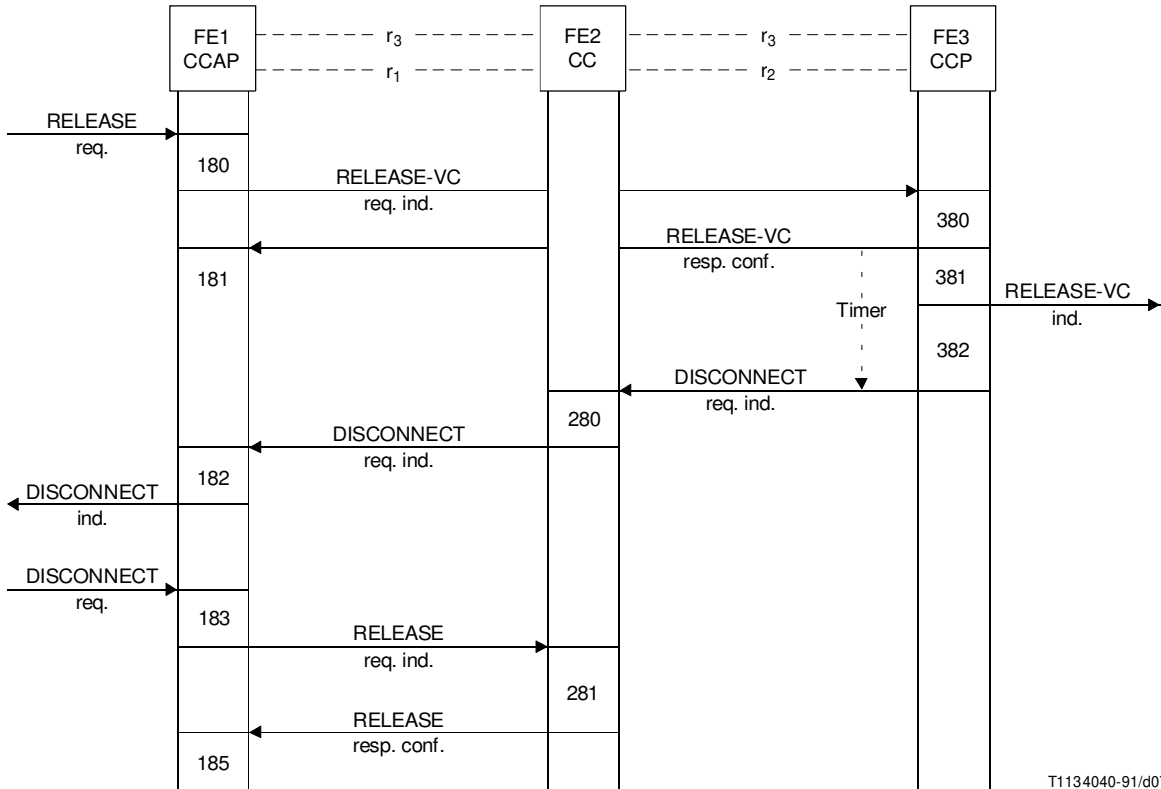

T1134040-91/d07

NOTE – The CCP functional entity ascertains that no other virtual calls are present on the affected B-channel.

FIGURE 1-7/Q.72
Disconnect access situation 1, calling access, calling user releases virtual call

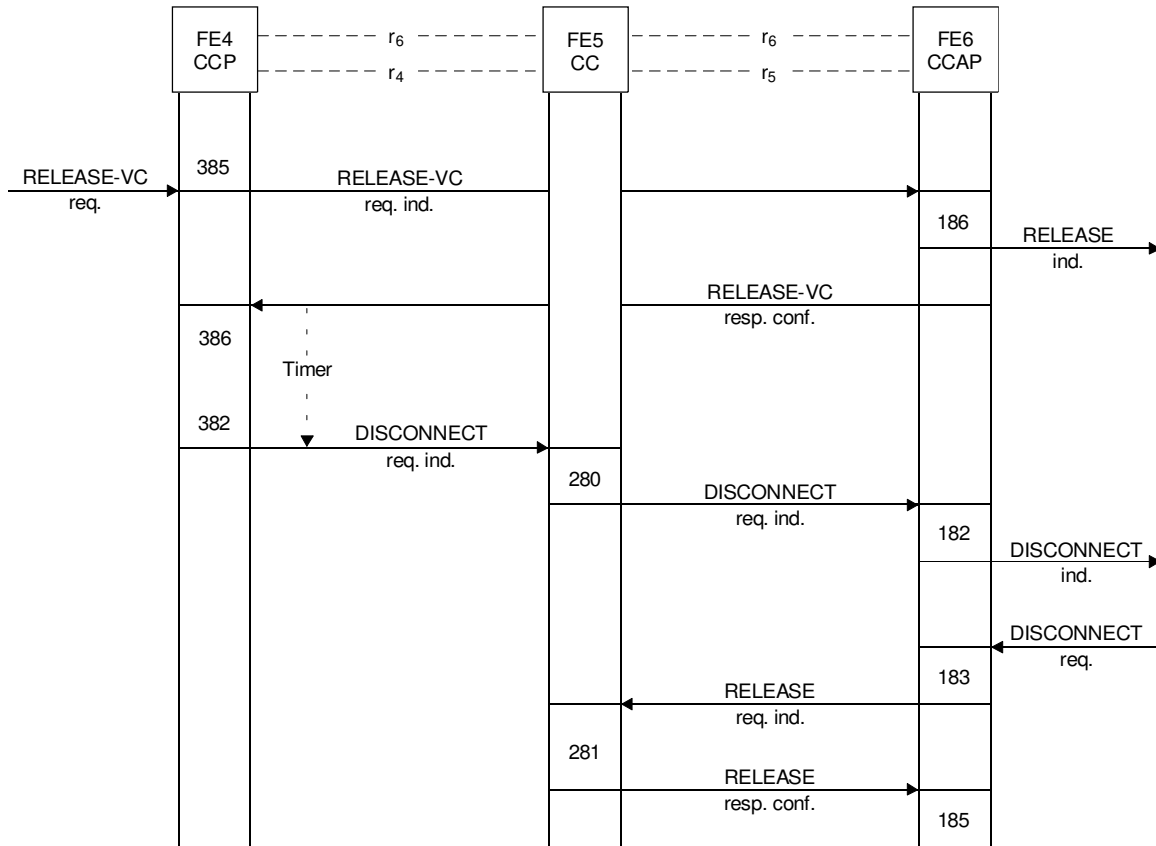

T1134050-91/d08

FIGURE 1-8/Q.72
Disconnect access situation 1, called access, calling user releases virtual call

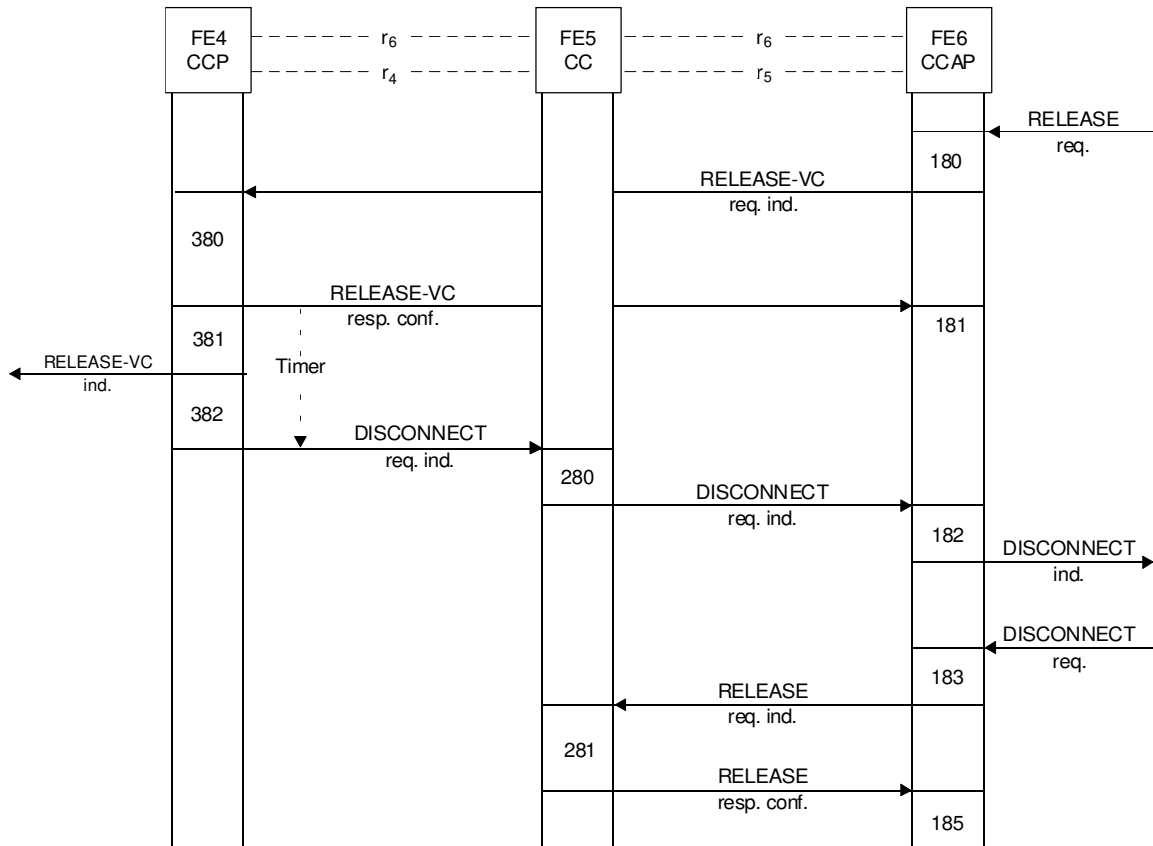

T1134060-91/d09

FIGURE 1-9/Q.72

**Disconnect access situation 1, called access,
called user releases virtual call**

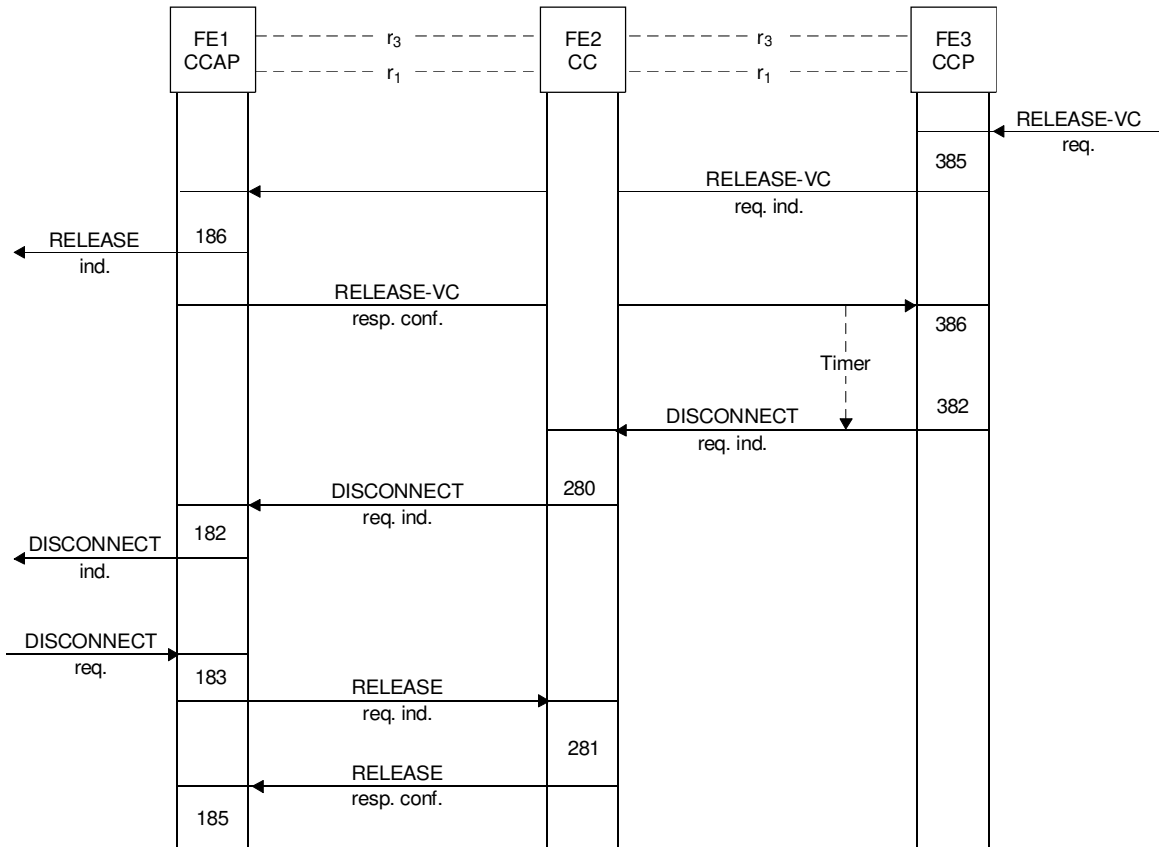

T1134070-91/d10

FIGURE 1-10/Q.72
**Disconnect access situation 1, calling access,
 called user releases virtual call**

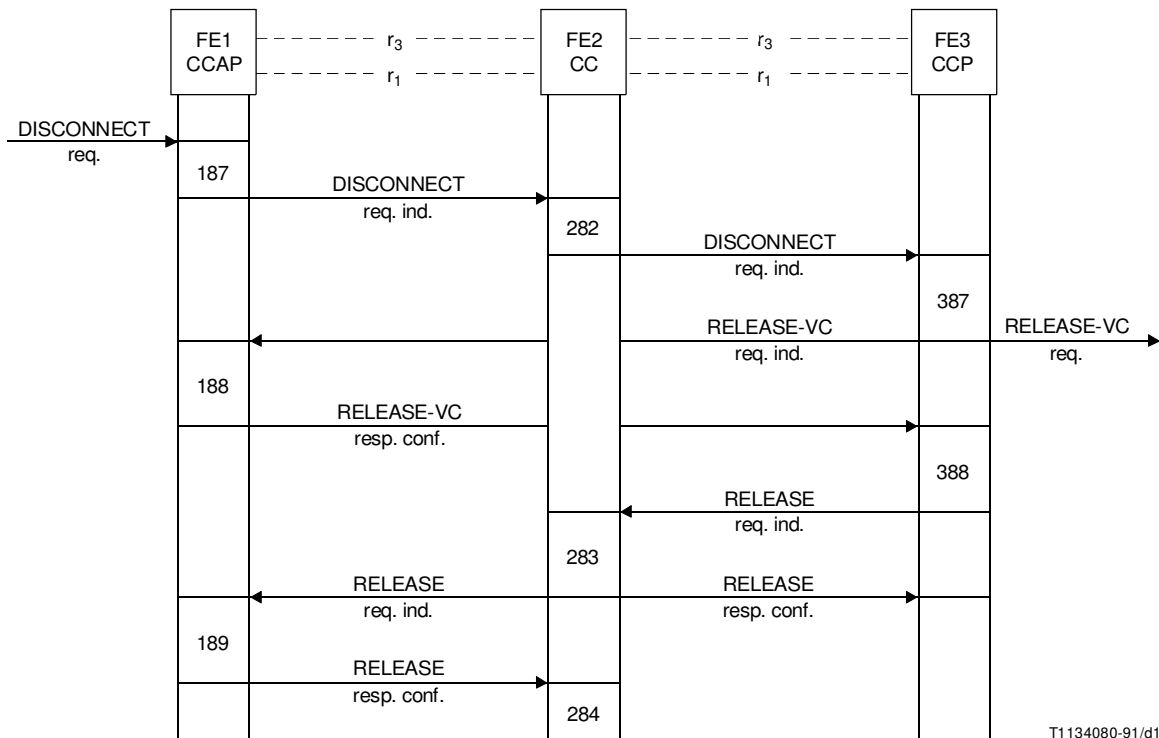

T1134080-91/d11

FIGURE 1-11/Q.72
**Disconnect access situation 1 or 2, calling access,
calling user releases physical channel**

The information flows are protocol independent but they do reflect the type of channel via which they are intended to be carried, i.e. inband or out-of-band. The names of inband information flows contain the suffix "VC".

For the D-channel packet transmission service, the D-channel is always semi-permanently connected to the packet-handler. The link layer protocol is LAPD and the packet level protocol is X.25. The service is initiated by the X.25 packet level procedures. Set-up of a physical connection is not required.

Where B-channel access is to be used for packet data transmission, the user includes information about the required packet switched bearer service capabilities in the SETUP request. If a B-channel access is already in use for packet data calls, and there is sufficient available capacity on it, it may be used for the new call and virtual call set-up proceeds using X.25 packet level procedures. If there is insufficient capacity, or if the user wishes to use a different B-channel or if a B-channel access connection to a packet handling function has not already been established, the Packet Call Control Agent interacts with the user and the network to establish an appropriate connection to the packet handling function and the virtual packet data call set-up proceeds.

The packet switching functions in the ISDN (or in a PSPDN in the interworking case) deliver the call to the called user using established access channels or using access channels established in response to the new virtual call.

1.7.1.1 Originating access situations

- *OAS1* – In this situation, either the user already has an established B-channel connection to a packet handler function, and he wants to use that channel for another virtual call, or he wants to use the D-channel for packet transport. In OAS1, only the r_3 relationship and the CCAP and CCP functional entities are involved.
- *OAS2* – In this situation, whether or not a B-channel connection exists to a packet handler, the user wants to establish a new B-channel connection to a packet handler function. In OAS2 the relationships r_1 and r_2 are used to establish the connection to the packet handler function. Then relationship r_3 is used to initiate a new virtual call.

1.7.1.2 Terminating access situations

- *TAS1* – In this situation, the user has subscribed to the “no notification” option. The network offers an incoming virtual call inband (e.g. Recommendation X.25) on the D-channel or an established B-channel, based on subscription. If no B-channel is established and if the user has not subscribed to D-channel delivery, the network initiates release of the virtual call.
- *TAS2* – In this situation, the user has subscribed to the “conditional notification” option. The network will deliver an incoming virtual call inband on the D-channel or on an established B-channel, based on subscription. If the B-channel is not available or the D-channel packet transport is not subscribed, the network will notify the user using out-of-band, e.g. Q.931 signalling. The user may then give directions as to how to further treat the virtual call.

A network may provide an option whereby an algorithm determines that no additional calls should be added to the established channel. The network may then reject the call or use out-of-band call offering. Only the latter case is described.

- *TAS3* – In this situation, the user has subscribed to the “unconditional notification” option. The network will offer the incoming virtual call using out-of-band signalling regardless of the presence or absence of a B-channel connection to a packet handler and regardless of D-channel transport subscription. The user may then give directions as to how to further treat the virtual call.

1.7.1.3 Virtual call disconnect access situations (DAS)

The actions taken when one or both users request disconnection of an established virtual call are dependent on user subscriptions.

- *DAS1* – In this situation, the user has subscribed to the conditional or unconditional notification class and may be provided with a time-out option. The timer is associated with a packet handler function and begins when all virtual calls on that channel have been released. When the timer reaches the end of its period, in the case of B-channel access, the network will initiate clearing of the B-channel. A new incoming or outgoing virtual call will disable the timer.
- *DAS2* – In this situation, the user has subscribed to the no-notification class, and must therefore maintain a semi-permanent connection in order to receive incoming virtual calls. In this case the user is not provided a time-out option. An established D-channel link or an established B-channel connection to a packet handler function will be maintained until disconnect is initiated by the user via an out-of-band message.

1.7.2 Description of information flows for call set-up and release

The information flows in the diagram in 1.7.1 are defined below.

1.7.2.1 SETUP-VC req. ind., corresponding to OAS1, OAS2, TAS1, 2, 3

This information flow is used to establish a virtual call from calling user to the network and from the network to the called user, where there is an already established link level access channel to the CCP functional entity. It is a confirmed information flow and the information flow “SETUP-VC resp. conf.” is returned if there is an acceptance of the incoming virtual call by the called user. The items of information are:

- called party address;
- calling party address;

- logical channel identification;
- user data;
- sequencing modulus.

1.7.2.2 SETUP-VC resp. conf., corresponding to OAS1, OAS2 and TAS1, 2, 3

This information flow appears in Figures 1-2 through 1-6. It is used to notify the network that an offered virtual call has been accepted by the called user and to signal this acceptance to the calling user. It is the confirmation of the “SETUP-VC req. ind.” information flow. The items of information are:

- called party address;
- calling party address;
- logical channel identification;
- user data;
- sequencing modulus.

1.7.2.3 SETUP-OR req. ind., corresponding to OAS2

This information flow is used to initiate a link layer channel from a user to a packet handler function over which virtual calls can subsequently be either originated or received. The items of information are:

- bearer capability;
- channel selection information.

1.7.2.4 SETUP-OR resp. conf., corresponding to OAS2

This information flow is used by the network to inform the user that the request for connection to a packet handler has been accepted. The item of information is

- channel selection information.

1.7.2.5 SETUP-TE req. ind., corresponding to TAS2 and TAS3

This information flow appears in Figures 1-5 and 1-6. It is used to notify the called user that there is an incoming call, and if appropriate, that an access channel is needed. It gives the user information about the incoming call which may influence his response. The items of information are:

- calling party address;
- called party address;
- bearer capability;
- channel selection information (if no access channel has been established);
- information rate;
- sequencing modulus.

1.7.2.6 SETUP-TE resp. conf., corresponding to TAS2 and TAS3

This information flow informs the network and the calling user that the called user accepts the delivery of this virtual call over an established or to be established channel. The items of information are:

- bearer capability;
- channel selection information (if no access channel has been established);
- terminating equipment information.

1.7.2.7 CONNECTED req. ind., corresponding to TAS2 or TAS3, no access channel established or established channel not selected

This information flow informs the CCAP that a B-channel connection has been established to a packet handler and that an inband virtual call is to be expected. The item of information is

- B-channel identification

1.7.2.8 RELEASE-VC req. ind., corresponding to DAS1 – Calling user releases virtual call (see Figures 1-7 and 1-8)

This information flow informs the calling CCP and the called CCAP that the calling user wishes to discontinue the virtual call. The item of information is

- logical channel identification.

1.7.2.9 RELEASE-VC resp. conf., corresponding to DAS1 – Calling user releases virtual call (see Figures 1-7 and 1-8)

This information flow informs the calling CCAP that the called CCAP and the calling CCP have completed the virtual call disconnect procedures. The item of information is

- logical channel identification.

1.7.2.10 DISCONNECT req. ind., corresponding to DAS1 – Calling/called user releases virtual call (see Figures 1-7 through 1-10)

This information flow informs the CC and CCAP that the CCP wishes to discontinue the B-channel to PHF connection. The item of information is

- channel identifier.

1.7.2.11 RELEASE req. ind., corresponding to DAS1 – Calling/called user releases virtual call (see Figures 1-7 through 1-10)

This information flow informs the CC that the user agrees to the proposed disconnection. The item of information is

- channel identifier.

1.7.2.12 RELEASE resp. conf., corresponding to DAS1 – Calling/called user releases virtual call (see Figures 1-7 through 1-10)

This information flow informs the CCAP that channel release procedures are complete. The item of information is

- channel identification.

1.7.2.13 RELEASE-VC req. ind., corresponding to DAS1 – Called user releases virtual call (see Figures 1-9 and 1-10)

This information flow informs the CCAP that the called user has released the virtual call. The item of information is

- logical channel identifier.

1.7.2.14 RELEASE-VC resp. conf., corresponding to DAS1 – Called user releases virtual call (see Figures 1-9 and 1-10)

This information flow informs the calling CCP and the called CCAP that the calling CCAP has completed virtual call release procedures. The item of information is

- logical channel identifier.

1.7.2.15 DISCONNECT req. ind., corresponding to DAS1 or DAS2 – Calling user releases physical channel (see Figure 1-11)

This information flow informs the CC and CCP that the calling user wishes to discontinue the B-channel to PHF connection. The item of information is

- channel identification.

1.7.2.16 RELEASE-VC req. ind., corresponding to DAS1 or DAS2 – Calling user releases physical channel (see Figure 1-11)

This information flow informs the CCAP to discontinue the virtual call. The item of information is

- logical channel identification.

1.7.2.17 RELEASE-VC resp. conf., corresponding to DAS1 or DAS2 – Calling user releases physical channel
(see Figure 1-11)

This information flow informs the CCP that the CCAP has completed virtual call release procedures. The item of information is

- logical channel identification.

1.7.2.18 RELEASE req. ind., corresponding to DAS1 or DAS2 – Calling user releases physical channel
(see Figure 1-11)

This information flow informs the CC and the CCAP that the B-channel connection to the PHF should be discontinued. The item of information is

- channel identification.

1.7.2.19 RELEASE resp. conf., corresponding to DAS1 or DAS2 – Calling user releases physical channel
(see Figure 1-11)

In the first instance, this information flow confirms to the CCP that the CC has disconnected the B-channel and the PHF. In the second instance, it informs the CC that the CCAP has completed channel release procedures. The item of information is

- channel identification.

1.7.2.20 RELEASE req. ind., corresponding to TAS (see Figure 1-6)

This information flow informs the CC and CCAP that the CCP wishes to disestablish the out-of-band signalling relation. There are no items of information.

1.7.2.21 RELEASE resp. conf., corresponding to TAS (see Figure 1-6)

This information flow informs the CCP and the CC that the CC and the CCAP, respectively, have completed disestablishment procedures for the out-of-band signalling relation. There are no items of information.

1.7.3 Information flow diagrams for data transfer

Figure 1-12 contains the information flows and functional entity action reference numbers needed for data transfer for a virtual call or for a permanent virtual circuit. The information flows are described in 1.7.4. The FEA-RNs are defined in 1.9.2.

1.7.4 Information flow descriptions for data transfer

1.7.4.1 Information flow corresponding to “USERDATA req. ind.”

This information flow sends user data to the network or to the user under sequence control. It can contain a request for end-to-end confirmation, identification of complete packet sequences, and identification of user control and user data packets. The items of information are:

- sequencing modulus;
- logical channel identification;
- packet sequence number;
- user data type (control/data);
- delivery confirmation request;
- packet linkage information.

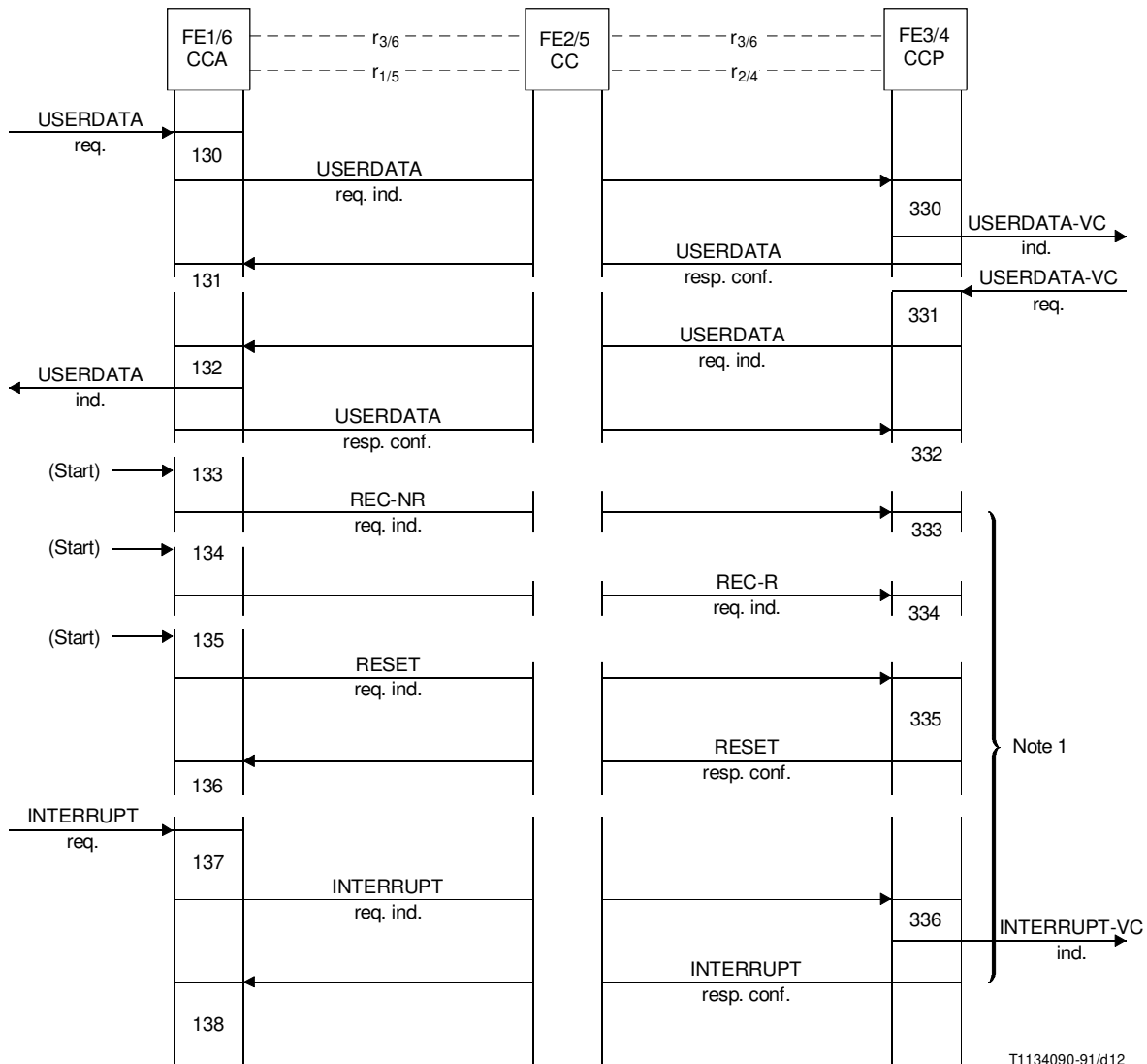

NOTES

- 1 These information flows also occur in the opposite direction, as for USERDATA.
- 2 This model is applicable to FE1, FE2 and FE3 and to FE4, FE5 and FE6.

FIGURE 1-12/Q.72
User data and data flow control information flows

1.7.4.2 Information flows corresponding to “USERDATA resp. conf.”

This information flow informs the network or user that a packet or sequence of packets has been correctly received and therefore the local copy may be discarded. A packet sequence number is given which acknowledges the last correctly received packet and establishes a new lower edge to the transmission permission window for net packets. The items of information are:

- sequencing modulus;
- logical channel identification;
- packet sequence number.

1.7.4.3 Information flow corresponding to “REC-NR req. ind.”

This information flow informs the network or user that no more data packets should be sent within the logical channel until further notice. It gives a packet sequence number which acknowledges the last correctly received packet and establishes the lower edge of the transmission window for new packets. The items of information are:

- sequence modulus;
- logical channel identification;
- packet sequence number.

1.7.4.4 Information flow corresponding to “REC-R req. ind.”

This information flow informs the user or network that more data may be sent in a logical channel. It gives a packet sequence number which acknowledges the last correctly received packet and establishes the lower edge of the transmission permission window for new packets. The items of information are:

- sequencing modulus;
- logical channel identification;
- packet sequence number.

1.7.4.5 Information flow corresponding to “RESET req. ind.”

This information flow informs the user or network to re-initialize the virtual call by setting the next packet sequence number to zero in each direction. The items of information are:

- sequencing modulus;
- logical channel identification;
- cause of reset action.

1.7.4.6 Information flow corresponding to “RESET resp. conf.”

This information flow informs the user or network that the RESET information flow was received and that the receiver is ready to resume sequenced flow control. The items of information are:

- sequencing modulus;
- logical channel identification.

1.7.4.7 Information flow corresponding to “INTERRUPT req. ind.”

This information flow delivers a user data packet, from user-to-network or network-to-user, that is not subject to the normal sequencing and flow control procedures. Only one such packet may be outstanding, that is, an acknowledgement must be received before a second interrupt packet may be sent. The information flow items are:

- sequencing modulus;
- logical channel information;
- user interrupt data.

1.7.4.8 Information flow corresponding to “INTERRUPT resp. conf.”

This information flow informs the user that an outstanding user data interrupt packet is acknowledged by the remote user. The items of information are:

- sequencing modulus;
- logical channel identification.

1.8 SDL diagrams for functional entities

For further study.

1.9 Functional entity actions (FEAs)

1.9.1 Functional entity actions for call set-up and release

The set of functional entity actions (FEA) which occurs in relation to the information flows described in 1.7.2 and shown in Figures 1-2 through 1-11 are identified by number and described below. Only actions related to network layer information flows are shown. Actions related to the link layer are not shown.

<i>Reference number</i>	<i>Actions</i>
100	Generate service request based on user actions. Identify an existing channel to a packet handling function (PHF). Select a logical channel. Initiate information flow to CCP.
101	Enter data transfer state. Set sequence count to zero. Notify user of successful call establishment.
102	Generate service request based on user actions. Identify idle access channel (B,D) desired. Initiate information flow to CC.
103	Interpret incoming call request. Notify called user.
104	Interpret PHF access confirmation. Notify virtual call agent of channel availability. Generate service request based on user actions. Identify the just selected channel to a packet handling function (PHF). Select a logical channel. Initiate information flow to CCP.
106	Release call reference. Initiate release response to CC.
107	Initiate information flow responding to incoming call. Indicate user channel selection.
150	Interpret service request. Busy logical channel. Notify called user of incoming call.
151	Relay virtual call acceptance. Enter data transfer state. Set sequence count to zero. Connect called user to logical channel. Update usage record.
180	Generate RELEASE-VC, information flow toward the CCP, based on user action. Discard any data waiting for transfer.

<i>Reference number</i>	<i>Actions</i>
181	Release the logical channel. Delete virtual call record.
182	Initiate the DISCONNECT information flow toward the user as an invitation to disconnect.
183	Receive the DISCONNECT information flow from the user, initiate the RELEASE information flow toward the CC.
185	Disconnect the B-channel.
186	Notify user of virtual call disconnect. Initiate RELEASE-VC information flow toward the CCP. Discard any data waiting for transfer. Idle the logical channel.
187	Receive disconnect request from user and initiate DISCONNECT information flow toward the CC.
188	Terminate data transfer state. Discard any data waiting for transfer. Idle the logical channel. Initiate RELEASE-VC toward the CCP.
189	Initiate the RELEASE information flow toward the CC. Idle the B-channel.
201	Interpret service request. Select idle B-channel and make it busy to other circuit-mode demands. Initiate request for idle PHF. Initiate interim information flow to user, if necessary. Initiate usage record (if required).
202	Interpret incoming call request. Select outgoing physical channel to CCAP. Initiate information flow to CCAP.
203	Interpret packet-handler request confirmation. Connect user B-channel to PHF. Initiate information flow to CCAP. Update usage record (if required).
204	Interpret response. Connect physical channels. Initiate information flow to CCAP and CCP.
205	Relay information flow from CCP to CCAP.
206	Relay information flow from CCAP to CCP.
207	Release call reference to CCP. Initiate release information flow to CCP and CCAP.
208	Release call reference to CCAP.
280	Initiate the DISCONNECT information flow toward the CCAP.
281	Release the B-channel to PHF connection and idle both resources.
282	Receive disconnect request from CCAP and initiate DISCONNECT information flow toward the CCP.
283	Disconnect the B-channel and the PHF. Idle the PHF. Initiate RELEASE confirmation toward the CCP. Initiate the RELEASE information flow toward the CCAP.
284	Idle the B-channel.

<i>Reference number</i>	<i>Actions</i>
300	Interpret service request. Busy logical channel. Initiate terminating or outgoing virtual call. Initiate usage record.
301	Relay virtual call acceptance. Enter data transfer state. Set sequence count to zero. Connect calling user and called or outgoing logical channels. Update usage record.
302	Interpret request for PHF. Select and assign idle PHF and make it busy to further requests. Connect PHF to user B-channel. Initiate information flow to CC confirming service request. Initiate usage record.
350	Generate incoming call request. Select physical and logical channels toward called user agent. Make logical channel busy. Initiate information flow to CCAP. Initiate usage record.
351	Interpret call acceptance information flow. Enter data transfer state. Set sequence count to zero. Relay virtual call acceptance toward calling user. Connect incoming and user agent logical channels. Update usage record.
352	Interpret incoming call request. Select physical channel for subsequent connections. Initiate information flow to CC.
353	Generate incoming call request. Select logical channels toward called user agent. Make logical channel busy. Initiate information flow to CCAP.
354	Interpret incoming call request. Initiate information flow to CC using a call reference.
355	Initiate release information flow to CC.
356	Release call reference.
380	Interpret incoming release request. Terminate data transfer state. Initiate information flow to CCA confirming RELEASE-VC.
381	Release the virtual call connection to the network or another user.
382	Determine whether there are any other virtual calls associated with the B-channel. If so, do nothing. If not, determine whether user is subscribed to conditional or unconditional notification. If so, initiate a timer, upon expiry of which the DISCONNECT information flow is initiated toward the CC. If not, i.e. user is subscribed to no notification, release virtual call records, leaving the B-channel connected to the PHF.
385	Initiate RELEASE information flow toward the CCAP. Discard any data waiting for transfer.
386	Interpret incoming release request. Idle the logical channel.

<i>Reference number</i>	<i>Actions</i>
387	Initiate RELEASE-VC information flow toward the CCAP. Terminate data transfer state. Discard any data waiting for transfer. Release the virtual call connection to the network or another user.
388	Idle the logical channel. Initiate RELEASE information flow toward the CC.

1.9.2 Functional entity actions for data transfer

The set of functional entity actions (FEA) which occur in relation to the information flows described in 1.7.4 and shown in Figure 1-12 are identified by number and described below. Only actions related to network layer information flows are shown. Actions related to the link layer are not shown. The FEA descriptions are independent of the direction of the virtual call set-up, except for usage recording.

<i>Reference number</i>	<i>Actions</i>
130	Select maximum allowed number of octets from the user data. Set conditions for packet linking, end-to-end confirmation and control/data indicator. Set sequence count to last sent packet count plus one. Check that sequence count is within the transmission permission window. Check that CCP receiver is ready. Make a local copy of the packet information to be sent to CCP. Initiate information flow in association with logical channel.
131	Discard local record of all packets acknowledged by the received information flow. Set a new lower window edge using the received sequence count.
132	Check that sequence count is as expected, if not, reset the logical channel. Deliver data packet to user. If end-to-end confirmation is in effect, set positive response in information flow to CCP. Initiate information flow to CCP acknowledging correct reception of this (and all preceding outstanding) packet(s) and supplying a new lower window edge.
133	Determine that throughput or other considerations require reduction in received data flow. Initiate REC-NR information flow.
134	Determine that throughput or other considerations permit resumption of data flow. Initiate REC-R information flow.
135	Determine that last received packet did not have the expected sequence count. Initiate information flow requesting reset of sequence counters to zero. Reset local sequence count to zero.
136	Enter flow control ready state.
137	Determine that user wants to send data on an interrupt basis. Check that no interrupt packets are outstanding. Initiate interrupt information flow. Make a local copy of the information flow sent to CCP. Inhibit subsequent outgoing interrupt information flows.
138	Discard local copy of information. Remove inhibition for subsequent interrupt requests.
330	Check that the received sequence count is as expected, if not, reset the logical channel. Forward data packet into network. If end-to-end confirmation is in effect, await response from the recipient of the data.

<i>Reference number</i>	<i>Actions</i>
330	Initiate information flow to CCAP acknowledging correct reception of this (and all preceding outstanding) packet(s), and supplying a new lower window edge. Update usage record (at the virtual call billable access).
331	Generate packet containing the maximum allowed number of octets from packet(s) received from the originator of the data. Include packet linking actions. Relay end-to-end confirmation and control/data indicators from the originator of the data. Set sequence count to last sent packet sequence count plus one. Check that sequence count is within the transmission permission window. Check that CCAP receiver is ready. Make a local copy of the packet information to be sent to CCAP. Initiate an information flow in association with the logical channel. Update usage record (at the virtual call billable access).
332	Discard local record of all packets acknowledged by the received information flow. Set a new lower window edge using the received sequence count. If end-to-end confirmation is in effect, relay the acknowledgement toward the originator of the data.
333	Cease sending data packets.
334	Resume sending data packets.
335	Reset local sequence count to zero. Initiate confirming information flow. Ignore data, interrupt, REC-NR and REC-R information flows.
336	Forward interrupt packet to network or terminating PHF. Await confirmation. Ignore subsequent interrupt packets. Relay confirming interrupt packet to CCAP.

1.10 Allocation of functions to physical entities

The functional model relates to functions involved in handling a single call or call attempt. The scenarios in Table 1-1 identify the roles a physical device (e.g. exchange, NT2, terminal equipment, etc.) may play in handling that call or call attempt. A specific physical device may fulfil different roles in different scenarios, e.g. a local exchange may provide both CC and CCP capabilities.

2 Frame mode virtual call and permanent virtual circuit bearer services

2.1 Scope

This Recommendation provides the stage 2 description for call set-up and release applicable to the Frame-mode virtual call service supported by an ISDN.

This Recommendation is specified according to the methodology specified in Recommendation Q.65 [3] and is based on the stage 1 description for frame mode service of Recommendation I.233.

This Recommendation is applicable to stage 3 Recommendations for the ISDN packet mode service. The term “stage 3” is also defined in Recommendation I.130 [1].

TABLE 1-1/Q.72
Physical allocation of functions

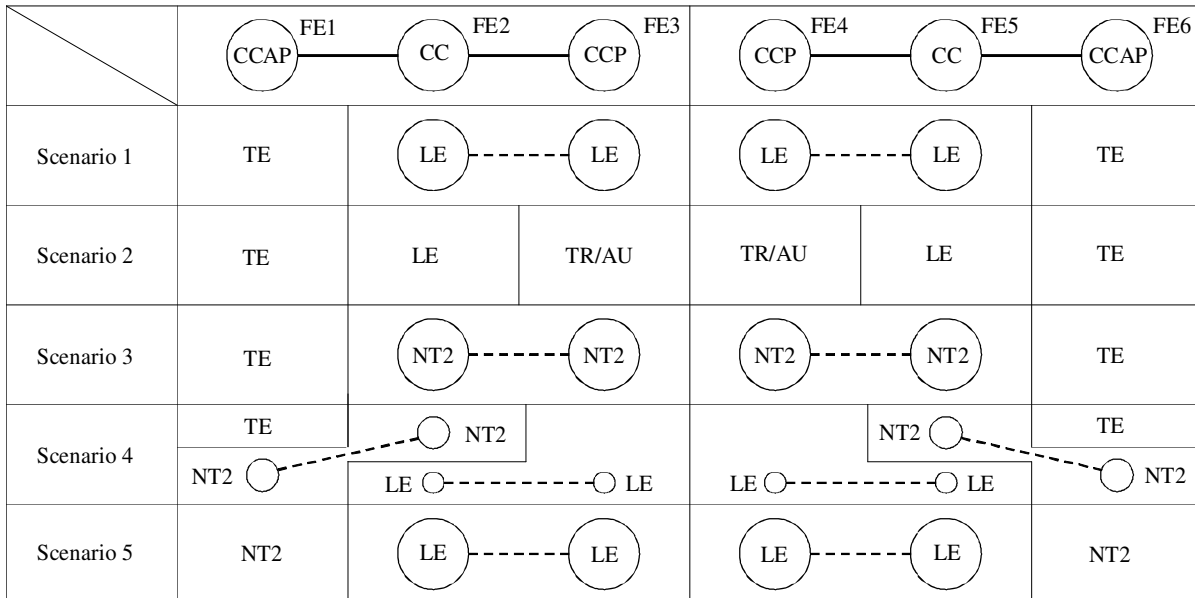

T1134100-91/d13

AU Access unit
LE Local exchange
NT2 Network termination type 2 (e.g., an ISPBX)
PH Packet handler
TE Terminal equipment
TR Transit exchange

NOTE – Entities connected by a dashed line are the same physical entity.

Notes corresponding to Scenarios:

Scenario 1 – Applies to B- or D-channel usage.

Scenario 2 – B-channel usage only. Applies to originating access. Applies to terminating access for the “no notification” case only. Other terminating cases are for further study.

Scenario 3 – Applies to B- or D-channel usage.

Scenario 4 – B-channel usage only. An originating user requests NT2 to provide a B-channel to a PH in the LE. A terminating local exchange requests NT2 to provide a B-channel connection to a B-channel of the TE. In either case, the user has exclusive use of the NT2 to LE B-channel. The use of the D-channel is for further study. The NT2 provides the CC function for the TE and appears to be a CCA function to the LE.

Scenario 5 – Applies to B- or D-channel usage. The NT2 provides the PH and may provide packet-mode multiplexing of calls from different users. The LE is not aware of this.

2.2 References

The references are cited at the appropriate places in the text and the publications are listed hereafter. For dated references, subsequent amendments to, or revisions of, any of these publications apply to this Recommendation only when incorporated in it by amendment or revision. For undated references, the latest edition of the publication referred to applies.

- [1] CCITT Recommendation I.130 (1988) *Method for the characterization of telecommunication services supported by an ISDN and the network capabilities of an ISDN.*
- [2] CCITT Recommendation I.112 (1988) *Vocabulary of terms for ISDNs.*
- [3] CCITT Recommendation Q.65 *Stage 2 of the method for the characterization of services supported by an ISDN.*
- [4] CCITT Recommendation Q.933 (1993) *Digital subscriber Signalling System No. 1. Signalling specification for frame mode bearer service.*

2.3 Definitions

The definitions in 1.3 also apply.

frame relaying: this bearer service provides the order preserving bidirectional transfer of service data units (layer 2 frames) from one S- or T- reference point to another. The data units are routed through the network on the basis of an attached label. This label is a logical identifier with local significance.

This bearer service:

- 1) preserves order as given at S or T reference point;
- 2) deletes transmission, format, and operational errors (e.g. frames with unknown label);
- 3) transports frames transparently;
- 4) does not acknowledge frames (within the network).

All of the above functions are based on the core functions described in Recommendation I.233, Part 1.

frame switching: This bearer service provides the order preserving bidirectional transfer of service data units (layer 2 frames) from one S- or T-reference point to another. The data units are routed through the network on the basis of an attached label. This label is a logical identifier with local significance.

This bearer service:

- 1) provides for the acknowledged transport of frames;
- 2) detects and recovers from transmission, format, and operational error;
- 3) detects and recovers from lost or duplicate frames;
- 4) provides flow control.

All of the above functions are based on Recommendation I.233, Part 2.

2.4 Symbols and abbreviations

CCAP	Call Control Agent – Packet mode
CCP	Call Control Packet mode
FE	Functional Entity
FEA	Functional Entity Action
FH	Frame Handler
LE	Local Exchange
NT2	Network Termination – Type 2
TR	Transit Exchange
TE	Terminal Equipment.

2.5 Description

2.5.1 General

This bearer service category provides the unrestricted transfer (without alteration) of user information in a packetized manner over a virtual circuit within a B- or D-channel at the S/T reference point. Signalling information for virtual call and/or possibly OAM information for permanent virtual circuit services are/is transferred via B- or D-channel as described in Recommendation I.233, and using the procedures in Recommendation Q.933.

2.5.2 Service invocation

Users indicate their required bearer service capabilities at the time of call set-up by including appropriate information in the service request sent to the network via the user-network signalling channel. The service allows for the establishment of multiple virtual connections to a point-to-point configuration over the same physical interface.

The user specifies several parameters [e.g. throughput and Quality of Service (QOS) parameters] at call set-up. The throughput rate may be characterized by a group of parameters such as peak bit rate and average bit rate. If a physical channel is already in use for virtual channel calls and there is sufficient available capacity on it, it may be used for the new call. If there is insufficient capacity, or if the user and/or network wishes to use a different physical channel the call control agent will interact with the user and the network to establish the appropriate connection.

2.5.2.1 Service invocation – Case A

If the frame handling (FH) capability is not provided by the local exchange, then the user may obtain access via a remote exchange (called “Case A”). If a B-channel to a remote frame handler exists (due to the presence of another virtual call) the calling user may initiate a call by providing the called user E.164 directory number. If not, or if a different channel is desired, the calling user must provide separate E.164 numbers for each stage of the two-stage procedure. The first number is to a remote FH function which, if available, responds with an answer signal and results in a circuit-mode clear digital channel. The second number is the E.164 number of the called user.

If the called user must be reached via a remote FH, then the term “Case A” also applies to the terminating access. The remote FH must determine if an acceptable B-channel exists to the called user (e.g. due to the presence of another virtual call). If so, the virtual call is completed on that B-channel. Otherwise the remote FH must initiate a circuit mode call to the called user, receive answer, and establish an FM connection to the called user. The virtual call is then established using this channel.

2.5.2.2 Service invocation – Case B

If the FH function is available in the local exchange, the term “Case B” applies. The calling user provides the called user E.164 number and, if necessary, B-channel selection information. The local exchange provides a connection, if needed, to the local FM function. At the called local exchange a connection to an FH is provided, if needed, after alerting the called user and receiving an answer response.

2.5.3 Parameter negotiation

For Frame mode bearer service there exists a need to progress call establishment while modifying (reducing) the Quality of Service parameters requested by the calling entity. As part of the negotiation process, a network (exchange) entity and/or a called user entity will determine if it has the resources to support the requested parameter values. If not, the network (exchange) entity and/or the called user entity will adjust (reduce) the requested parameters, bounded by some minimum specified by the calling entity, as the call progresses. If the minimum cannot be supported, the network (exchange) and/or the called user entity will deny the request.

In order to provide parameter negotiation, through connect is provided at the originating and tandem exchanges on receipt of the final confirmation from the called user entity.

2.6 Derivation of the functional model

The functional model in Figure 2-1 is a basis for representing the functional entities and information flows for a frame mode call originated by a user interacting with FE1 while the connection is established. The information flows between FE1 and FE2 are implemented over channels established on either a permanent or demand basis. Similarly, the information flows between FE4 and FE5 are implemented over channels established by the user or network. Where the network frame handling function is provided in a local exchange, whether on a demand or permanent basis, the term “Case B” is used. When the network function is provided in a “remote”, i.e. transit, exchange by means of a B-channel switched connection in a local exchange or a permanent channel, the term “Case A” is used. The call control functions needed to establish these channels are circuit-mode call procedures and are not included in this Recommendation.

CCAPs are functional entities that serve the users and are responsible for initiating functional requests and interacting with CCP. CCPs are functional entities that cooperate with each other to provide the services requested by the CCAP. r_1 , r_2 , and r_3 are relationships between functional entities wherein information flows occur in order to process call attempts or service requests. The relationship r_3 differs from r_1 in that it covers information flows for the case where a setup message must be broadcast to multiple end-points on an interface.

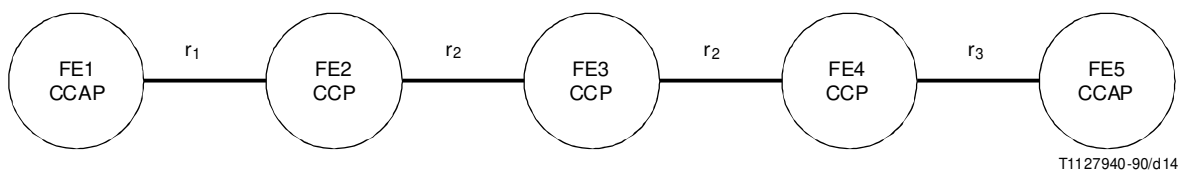

FIGURE 2-1/Q.72

Functional model for Frame mode bearer service

2.6.1 Description of the call control agent (CCAP) functional entities

The originating CCAP (FE1) functional entity will

- 1) access the ISDN service providing capabilities of the CCP entities, using service requests for the establishment (where required), manipulation and release of physical channels;
- 2) establish, manipulate (e.g. throughput and QOS parameters), and release frame mode calls over the established physical channels;
- 3) receive information relating to the ISDN call or use of facilities from the CCP entities, and relay them to the user;
- 4) maintain ISDN frame mode call state information as perceived from this functional end-point of the service.

The terminating CCAP (FE5) functional entity will

- 1) access the ISDN service providing capabilities of the CCP entities using service requests for the establishment (where required), manipulation and release of physical channels;
- 2) establish, manipulate (e.g. throughput and QOS parameters), and release frame mode calls over the established physical channels;
- 3) receive information relating to the FM call/connection or use of facilities from the CCP entities, and relay them to the user;
- 4) maintain FM call state information as perceived from this functional end-point of the service (i.e. a single ended view of the FM call/connection).

In a single service example, one CCAP originates the call and the other CCAP terminates the call. The functions and relationships involved are not symmetric. This asymmetry is reflected in the different functional entity designations and in the different relationship designations between CCAP and CCP (r_1 and r_3).

2.6.2 Description of the call control (CCP) functional entities

FE2 represents an originating cc' functional serving the calling party's CCAP which will

- 1) establish, manipulate (e.g. throughput and QOS parameters), and release frame mode bearer connections and/or physical channels (upon request of the CCAP entity);
- 2) associate and relate the CCAP entities involved in access for a particular call and/or service;
- 3) manage the relationship between the CCAP entities involved in a FM call or use of facilities.

FE3 represents a transit CCP function. There can be more than one FE3 functional entity involved in a call, depending on depth of the network hierarchy.

FE4 represents a terminating CCP function serving the called party's CCAP.

2.7 Information flows

Information flows for establishment and release are shown in Figures 2-2 and 2-3 respectively.

2.7.1 Definition of information flows

2.7.1.1 SETUP req. ind.

This information flow is used to establish an FM bearer connection. It is a confirmed information flow. The information flow "SETUP resp. conf." is returned if there is an acceptance of the incoming FM bearer connection by the called user. The request for establishment can be originated by either the network or user. This information flow is within the r_1 , r_2 and r_3 relationships.

The items of information are:

<i>Item</i>	<i>Relationship</i>	<i>Req. ind.</i>
Call reference	r_1, r_2, r_3	Mandatory
Bearer capability	r_1, r_2, r_3	Mandatory
Channel ID(s)	r_2, r_3	Mandatory
Called party number	r_1, r_2	Mandatory
Calling party number	r_1, r_2, r_3	Optional
Data link connection ID	r_1, r_2, r_3	Mandatory
Performance attributes	r_2, r_3	Mandatory
HLC r_1, r_2, r_3	Optional	
LLC	r_1, r_2, r_3	Optional

2.7.1.2 SETUP resp. conf.

This information flow is used to notify the network that an offered FM bearer connection has been accepted by the called user, and to signal this acceptance to the calling user. It is the confirmation of the "SETUP req. ind." information flow. This information flow appears within the r_1 , r_2 and r_3 relationships.

The items of information are:

<i>Item</i>	<i>Relationship</i>	<i>Resp. conf.</i>
Call reference	r_1, r_2, r_3	Mandatory
Connected number	r_1, r_2, r_3	Optional
Data link connection ID	r_1, r_2, r_3	Optional (see Note)
Performance attributes	r_1, r_2, r_3	Mandatory
HLC r_1, r_2, r_3	Optional	
LLC	r_1, r_2, r_3	Optional

NOTE – Mandatory if this information flow is the first information flow sent in response to SETUP req. ind.

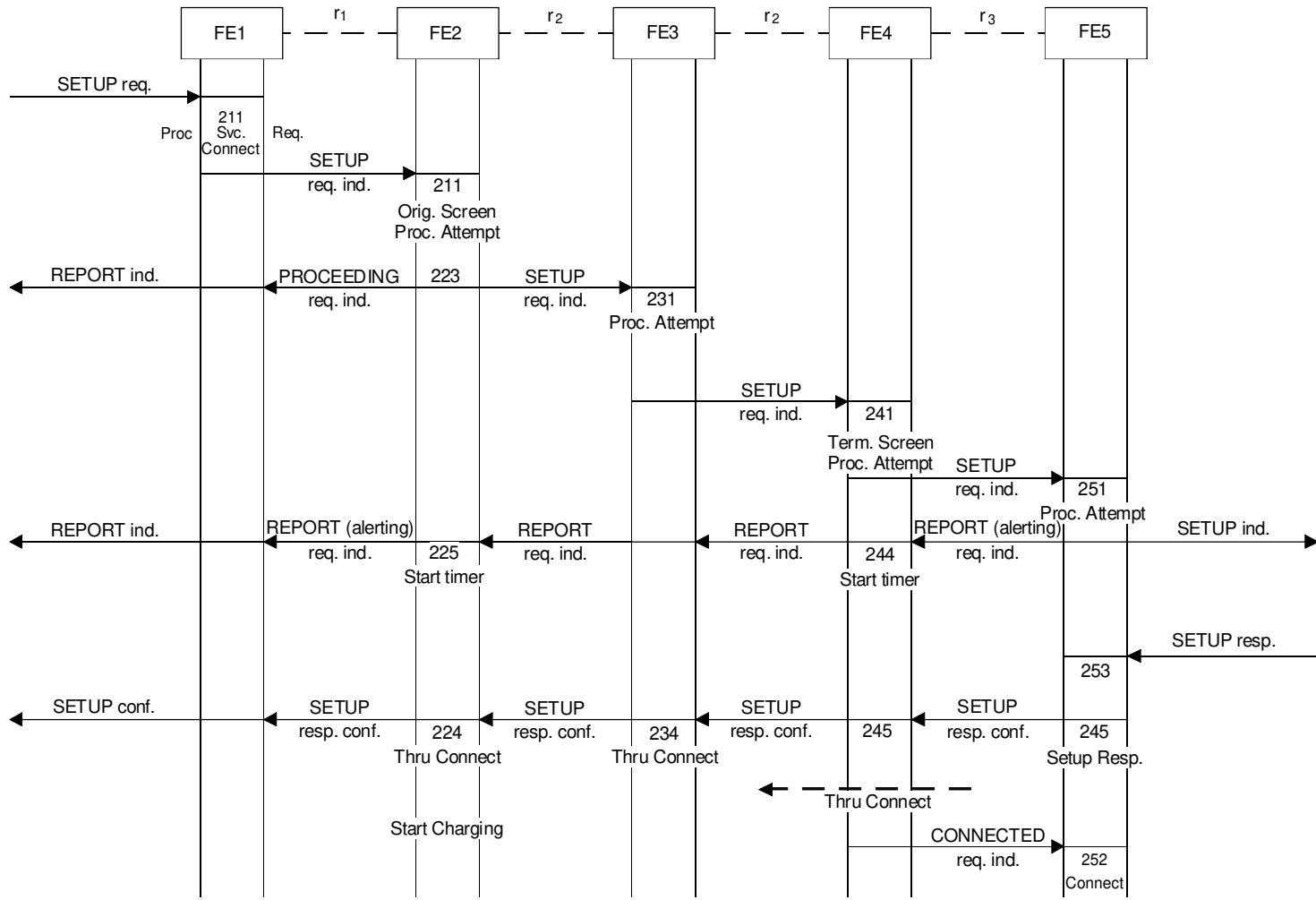

T1132510-91/d16

FIGURE 2-2/Q.72
Successful frame mode call set-up

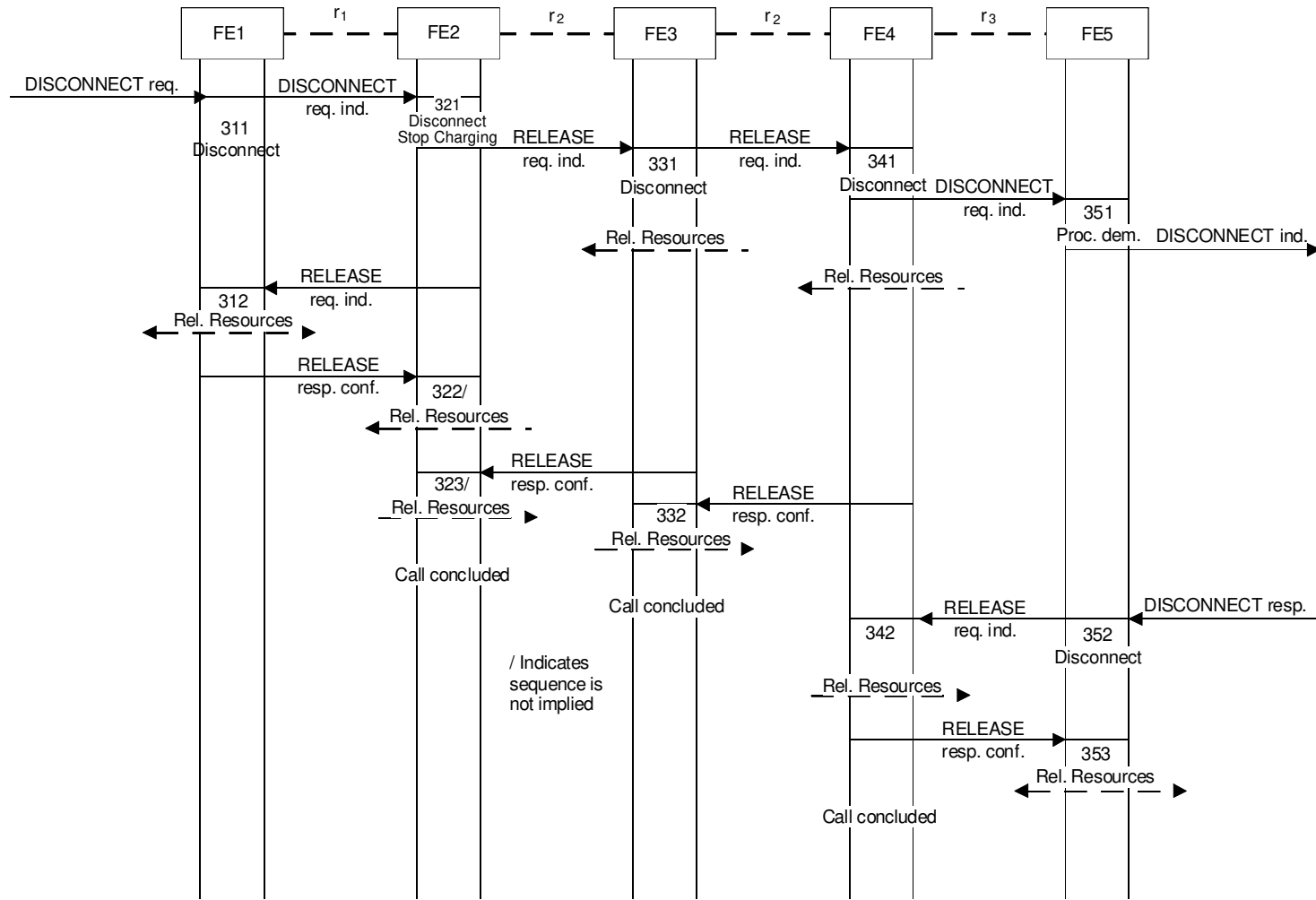

T1132520-91/d17

FIGURE 2-3/Q.72
Normal clearing – frame mode call calling party disconnect

2.7.1.3 PROGRESS req. ind

This information flow optionally reports that the received FM bearer connection set-up is valid and authorized and that further routing and progressing of the bearer connection request is proceeding. The user entity is not required to provide this indication. This information flow is not confirmed and appears within relationship r₁.

The items of information are:

<i>Item</i>	<i>Relationship</i>	<i>Req. ind.</i>
Call reference	r ₁	Mandatory
Cause	r ₁	Optional
Progress indicator	r ₁	Mandatory

2.7.1.4 CONNECTED req. ind.

This information flow is used to acknowledge that a previously sent SETUP resp. conf. has been received and accepted. This is an unconfirmed information flow within the r₃ relationship, and is sent from FE4 to FE5.

The item of information is:

<i>Item</i>	<i>Relationship</i>	<i>Req. ind.</i>
Call reference	r ₃	

2.7.1.5 REPORT req. ind.

This information flow is used to report status and/or other types of information across the network. The type of information may be indicated (e.g. alerting). This is an unconfirmed information flow appearing within the relationship of both r₁ and r₂.

The items of information are:

<i>Item</i>	<i>Relationship</i>	<i>Req. ind.</i>
Call reference	r ₁ , r ₂ , r ₃	
Channel ID	r ₁ , r ₂ , r ₃	Optional
Data link connection ID	r ₁ , r ₂ , r ₃	Optional (see Note)
Called line category	r ₂	Mandatory
Called line status	r ₂	Mandatory
Report type	r ₂	Mandatory
Connection request	r ₂	Optional

NOTE – Mandatory if this information flow is the first information flow sent in response to SETUP req. ind.

2.7.1.6 RELEASE req. ind. and RELEASE resp. conf.

This information flow is used to free resources associated with the FM call/connection such as call reference and data link connection ID. This is a confirmed information flow whose confirmation indicates that all resources previously associated with the connection have been freed. It appears within the r₁, r₂ relationships.

The items of information are:

<i>Item</i>	<i>Relationship</i>	<i>Req. ind. + resp. conf.</i>
Call reference	r ₁ , r ₂ , r ₃	Mandatory
Channel ID	r ₁ , r ₂ , r ₃	Optional
Cause	r ₁ , r ₂	Mandatory

2.7.1.7 DISCONNECT req. ind.

This information flow is used to signal that the end user has disconnected from the connection or cannot be connected (e.g. because of called user busy). It is used to solicit a confirmed release of bearer connection identifiers and other resources associated with the FM bearer connection. DISCONNECT req. ind. is not confirmed, and appears within the r₁ relationship.

The items of information are:

<i>Item</i>	<i>Relationship</i>	<i>Req. ind.</i>
Call reference	r ₁ , r ₂ , r ₃	Mandatory
Channel ID	r ₁ , r ₂ , r ₃	Optional
Cause	r ₁ , r ₃	Mandatory

2.8 SDL diagrams for functional entities

The SDL diagrams for the frame mode service for the user network interface are essentially the same as for the circuit switched signalling. Therefore, the reader should consult, Figure 2-13/Q.71 and Figure 2-17/Q.71. The SDL diagrams for the network/network interfaces are for further study.

2.9 Functional entity actions (FEAs)

- Reservation: The resources are reserved for one user from a management point of view, therefore they are blocked from other users bearer connection requests, but not yet usable for information transfer.
- Through connection: The resources are made usable for information transfer.

Functional entities are assumed to have the basic capabilities required to properly perform their assigned functions in ISDN frame mode (e.g. synchronization, signalling capabilities, etc.). In addition, the actions that occur at the functional entities during call processing stages for providing services described in this Recommendation have been given reference numbers and brief descriptions. The reference numbers are shown on the information flow diagrams. Following is a list of descriptions of actions, together with references to the information flow diagrams.

NOTE – Call set-up with digit-by-digit sending and tones/announcements is not supported.

<i>Reference number</i>	<i>Actions</i>
211	<p><i>Process service request</i></p> <ul style="list-style-type: none"> – Receive, analyse and acknowledge (as required) user's SETUP req. – Request network access resource. – Check for resource availability. – Formulate SETUP req.ind. – Select and reserve local resources. <p><i>Connect</i></p> <ul style="list-style-type: none"> – Establish FM bearer connection as required.
221	<p><i>Perform originating screening</i></p> <ul style="list-style-type: none"> – Receive and react to SETUP req. ind. from the CCAP. – Analyse the service request. – Verify the user's authorization, capabilities (including throughput and QOS attributes), and availability of appropriate resources. <p><i>Process attempt</i></p> <ul style="list-style-type: none"> – Analyse information (called number throughput, QOS parameters, routing requirements, etc.). – Check resource availability on physical channel. – Modify throughput and performance attributes if required. – Select data link connection ID. – Reserve incoming resources. – Determine connection elements type, outgoing resources, charging treatment, network management controls in effect, and any other elements involved in call control.

Process attemp (cont.)

- Reserve outgoing resources and any other required resources.
- Formulate and send PROCEEDING req. ind. and SETUP req. ind.
- Start call control timing, as required.

224 *Through connect*

- Receive and react to SETUP resp. conf.
- Establish through connection as required
- Formulate and send SETUP resp. conf.

Start charging

- Start charge timing.

225 *Start timer*

- Receive and react to REPORT req. ind.
- Start user-answer timer.

231 *Process attempt*

- Receive and analyse SETUP req. ind.
- Reserve incoming resources, if applicable.
- Analyse called number, routing information, network management, and/or priority information.
- Modify throughput and QOS parameters if required.
- Determine connection elements type, outgoing resource.
- Select and reserve outgoing resource; other resources as required, and path through the entity.
- Formulate and send SETUP req. ind.

234 *Through Connect*

- Modify resources (if required) based on agreed parameters.
- Establish through connection.
- Formulate and send SETUP resp. conf.

241 *Perform Terminating Screening*

- Receive and analyse SETUP req. ind.
- Analyse service request, called number, throughput, QOS parameters and any routing information.
- Verify called user's authorization/capabilities.
- Reserve incoming resources.
- Modify throughput and QOS parameters, if required.

Process attempt

- If needed, establish circuit-mode channel to called user using Recommendation Q.931 procedures.
- Select and reserve outgoing resource, other resources, and path through the entity.
- Select call reference.
- Select data link connection ID.
- Formulate and send SETUP req. ind.
- Start user-response timer.

244 *Report processing*

- Formulate and send REPORT req. ind.
- Start user-response timer, if required.

<i>Reference number</i>	<i>Actions</i>
245	<p><i>Through connect</i></p> <ul style="list-style-type: none"> – Receive and react to SETUP resp. conf. – Establish through connection. – Formulate and send SETUP resp. conf. and CONNECTED req. ind. – Stop user-response timer.
251	<p><i>Process attempt</i></p> <ul style="list-style-type: none"> – Receive and react to SETUP req.ind. – Analyse service request. – Identify called user. – Verify compatibility of called user terminal. – Reserve resources. – Send SETUP ind. to called user. – Formulate and send REPORT (Alerting) req. ind.
252	<p><i>Connect</i></p> <ul style="list-style-type: none"> – Receive and react to CONNECTED req. ind. – Establish connection.
253	<p><i>Setup response</i></p> <ul style="list-style-type: none"> – Modify throughput and performance attribute, if required. – Formulate and send SETUP resp. conf.
311	<p><i>Disconnect</i></p> <ul style="list-style-type: none"> – Recognize user DISCONNECT req. – Formulate and send DISCONNECT req. ind. – Release resources – both directions. – Update bandwidth resources.
321	<p><i>Disconnect</i></p> <ul style="list-style-type: none"> – Receive and react to DISCONNECT req. ind. – Formulate and send RELEASE req. ind. <p><i>Stop charging</i></p> <ul style="list-style-type: none"> – Stop charging.
322	<p><i>Release resources</i></p> <ul style="list-style-type: none"> – Receive and react to RELEASE resp. conf. – Release resources in direction of incoming RELEASE resp. conf. – Disconnect resources including data link connections ID. – Update bandwidth resources.
323	<p><i>Release resources</i></p> <ul style="list-style-type: none"> – Receive and react to RELEASE resp. conf. – Release resources. – Update bandwidth resources.
331	<p><i>Disconnect</i></p> <ul style="list-style-type: none"> – Receive and react to RELEASE req. ind. – Disconnect resources data link connection ID. – Formulate and RELEASE req. ind. <p><i>Release resource</i></p> <ul style="list-style-type: none"> – Release resources in direction of incoming RELEASE req. ind. – Formulate and send RELEASE resp. conf. – Update bandwidth resources.

<i>Reference number</i>	<i>Actions</i>
332	<p><i>Release resources</i></p> <ul style="list-style-type: none"> – Receive and react to RELEASE resp. conf. – Release resource in direction of incoming RELEASE resp. conf.
341	<p><i>Disconnect</i></p> <ul style="list-style-type: none"> – Receive and react to RELEASE req. ind. – Formulate DISCONNECT req. ind. <p><i>Release resources</i></p> <ul style="list-style-type: none"> – Release resources including data link connection ID in direction of incoming RELEASE req. ind. – Formulate and send RELEASE resp. conf. – Update bandwidth resources.
342	<p><i>Release resources</i></p> <ul style="list-style-type: none"> – Release resources in direction of incoming RELEASE req. ind. – Formulate and send RELEASE resp. conf. – Update bandwidth resources.
351	<p><i>Process demand</i></p> <ul style="list-style-type: none"> – Receive and react to DISCONNECT req. ind. – Initiate action to send DISCONNECT ind. to user.
352	<p><i>Disconnect</i></p> <ul style="list-style-type: none"> – Receive and react to DISCONNECT req. from user. – Disconnect resources data link connection ID. – Discard any data waiting to be transferred.
353	<p><i>Release resources</i></p> <ul style="list-style-type: none"> – Receive and react to RELEASE resp. conf. – Release resources including data link connection ID in both directions. – Update bandwidth resources.

2.10 Allocation of functions to physical entities

The functional model relates to functions involved in handling a single call/connection or call/connection attempt. The scenarios in Table 2-1 identify the roles a physical device (e.g. exchange, NT2, terminal equipment, etc.) may play in handling the call/connection or call/connection attempt.

In these scenarios, the circuit-mode channel which is, in most cases, established prior to frame-mode call origination is shown schematically in the leftmost “FH Access” column. The circuit-mode channel which is, in many cases, established prior to completion of the frame-mode virtual circuit at the terminating FE4 is shown schematically in the rightmost column titled “FH Access”. The physical entities shown in the “FH Access” columns are transparent for frame-mode call control and transport functions.

NOTES

1 Each scenario is shown as symmetric. However, any originating combination of physical entities may be connected to any terminating combination of physical entities.

2 The “Frame handler (FH) access” column indicates which channels may be used and the switched circuit-mode access which is established prior to the initiation of a frame-mode virtual call or permanent virtual circuit.

3 The broken line between NT2 symbols indicates a single NT2 providing two functional entities.

TABLE 2-1/Q.72
Physical allocation of functions

Functional entities Scenario	FE1	r ₁	FE2	r ₂	FE3	r ₂	FE4	r ₃	FE5
	FH Access				FH Access				
A-ISDN Public network Case B	TE	B or D	LE	TR	LE	B or D	TE		
B-NT2 Access to Public network Case B	TE	B X B NT2	LE	TR	LE	X NT2	TE		
C-ISDN Public network Case A	TE	B X B LE	TR	TR	TR	B X B LE	TE		
D-NT2 Access to Public network Case A	TE	B X B NT2	X B LE	TR	TR	X LE2	X NT2	TE	
E-Mixed Public/ Private Case B	TE	B or D	(NT2)	TR	(NT2)	B or D	TE		
	(NT2)	B or D	LE		LE	B or D	(NT2)		
F-Mixed Public/ Private Case A	TE	B or D	(NT2)	TR	(NT2)	B or D	TE		
	(NT2)	B X B	TR	TR	TR	X	(NT2)		
		LE				LE			

T1129950-91/d15