



INTERNATIONAL TELECOMMUNICATION UNION

ITU-T

TELECOMMUNICATION
STANDARDIZATION SECTOR
OF ITU

Q.617

(03/93)

INTERWORKING OF SIGNALLING SYSTEMS

INTERWORKING OF SIGNALLING SYSTEMS

—

**LOGIC PROCEDURES FOR INCOMING
SIGNALLING SYSTEM No. 7 (ISUP)**

ITU-T Recommendation Q.617

(Previously "CCITT Recommendation")

FOREWORD

The ITU Telecommunication Standardization Sector (ITU-T) is a permanent organ of the International Telecommunication Union. The ITU-T is responsible for studying technical, operating and tariff questions and issuing Recommendations on them with a view to standardizing telecommunications on a worldwide basis.

The World Telecommunication Standardization Conference (WTSC), which meets every four years, established the topics for study by the ITU-T Study Groups which, in their turn, produce Recommendations on these topics.

ITU-T Recommendation Q.617 was prepared by the ITU-T Study Group XI (1988-1993) and was approved by the WTSC (Helsinki, March 1-12, 1993).

NOTES

1 As a consequence of a reform process within the International Telecommunication Union (ITU), the CCITT ceased to exist as of 28 February 1993. In its place, the ITU Telecommunication Standardization Sector (ITU-T) was created as of 1 March 1993. Similarly, in this reform process, the CCIR and the IFRB have been replaced by the Radiocommunication Sector.

In order not to delay publication of this Recommendation, no change has been made in the text to references containing the acronyms "CCITT, CCIR or IFRB" or their associated entities such as Plenary Assembly, Secretariat, etc. Future editions of this Recommendation will contain the proper terminology related to the new ITU structure.

2 In this Recommendation, the expression "Administration" is used for conciseness to indicate both a telecommunication administration and a recognized operating agency.

© ITU 1994

All rights reserved. No part of this publication may be reproduced or utilized in any form or by any means, electronic or mechanical, including photocopying and microfilm, without permission in writing from the ITU.

**INTERWORKING OF SIGNALLING SYSTEMS –
LOGIC PROCEDURES FOR INCOMING SIGNALLING
SYSTEM No. 7 (ISUP)**

(Helsinki, 1993)

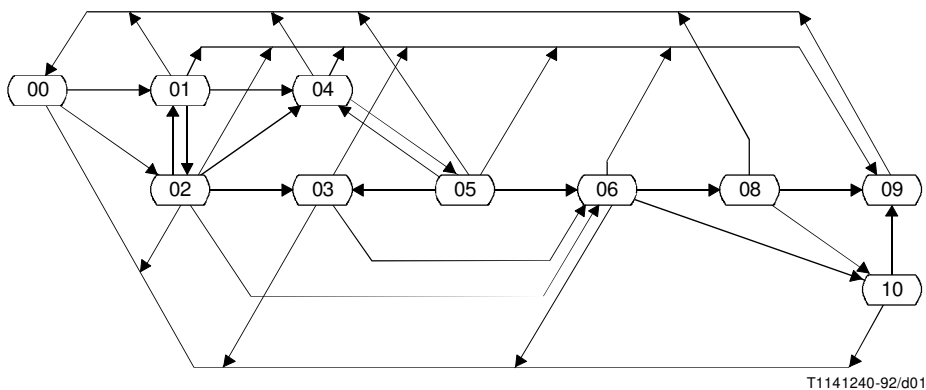

T1141240-92/d01

| State number | State description | Sheet reference | Timer running |
|--------------|---------------------------------------|-----------------|-----------------|
| 00 | Idle | 1, 13, 16 | |
| 01 | Wait for further digits | 2 | t_1, t_2 |
| 02 | Wait for digit analysis | 5 | t_1, t_2, t_3 |
| 03 | Wait for COT | 8 | t_1, t_2, t_3 |
| 04 | Wait for further digits; COT received | 3 | t_2 |
| 05 | Wait for digit analysis; COT received | 4 | t_2, t_3 |
| 06 | Wait for address complete | 10 | t_2, t_3 |
| 08 | Address complete; Wait for answer | 15 | |
| 09 | Wait for RLC | 13 | t_7 |
| 10 | Answered | 16 | t_6, t_9 |

FIGURE 1/Q.617
State overview diagram for incoming Signalling System No. 7 (ISUP)

Supervisory timers for incoming Signalling System No. 7 (ISUP)

| | |
|----------------------------|--|
| t ₁ = 10 - 15 s | Waiting for continuity |
| t ₂ = 15 - 20 s | Waiting for address signal |
| t ₃ = 20 - 30 s | Waiting for Address Complete signal |
| t ₅ = 1 minute | Stop repeat sending of Release on t ₇ timeout |
| t ₇ = 4 - 15 s | Waiting for Release Complete release |

Information contents of FITEs and BITEs

For the information contents of the following FITEs and BITEs see the contents of the corresponding messages in Recommendation Q.763:

| | |
|---------|--------------------------------|
| FITE A | Initial Address Message (IAM) |
| BITE 47 | Call Progress message (CPG) |
| BITE 48 | Connect message (CON) |
| BITE X | Address Complete Message (ACM) |
| BITE Y | Answer Message (ANM) |

Procedures not shown

Procedures related to the following messages are not shown in the logic procedures because of no relevancy for interworking or no usage defined yet:

| | | | |
|------|------|-----|------|
| BLO | CGU | FRJ | UBA |
| BLA | CGUA | GRA | UBL |
| CCR | CQM | GRS | UCIC |
| CFN | CQR | LPA | USR |
| CGB | FAA | OLM | |
| CGBA | FAR | RSC | |

Indicated fault procedures

| | |
|-----------------------------------|---|
| P ₁ (State 01, 02, 03) | Procedure for continuity recheck incoming |
| P ₂ (State 02, 05) | Procedure for test-call |

FIGURE 2/Q.617

Notes to incoming Signalling System No. 7 (ISUP)

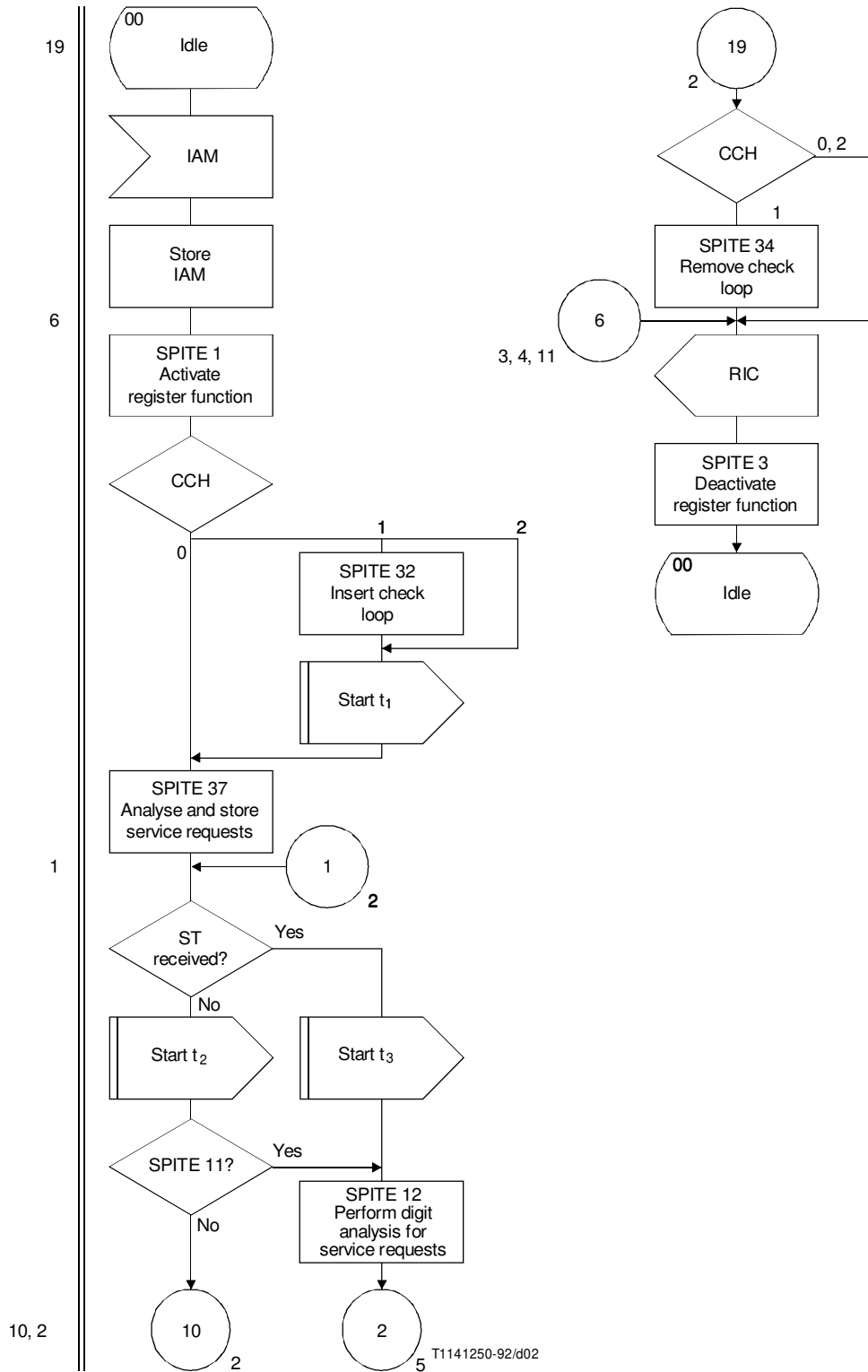

FIGURE 3/Q.617 (sheet 1 of 16)
Incoming Signalling System No. 7 (ISUP)

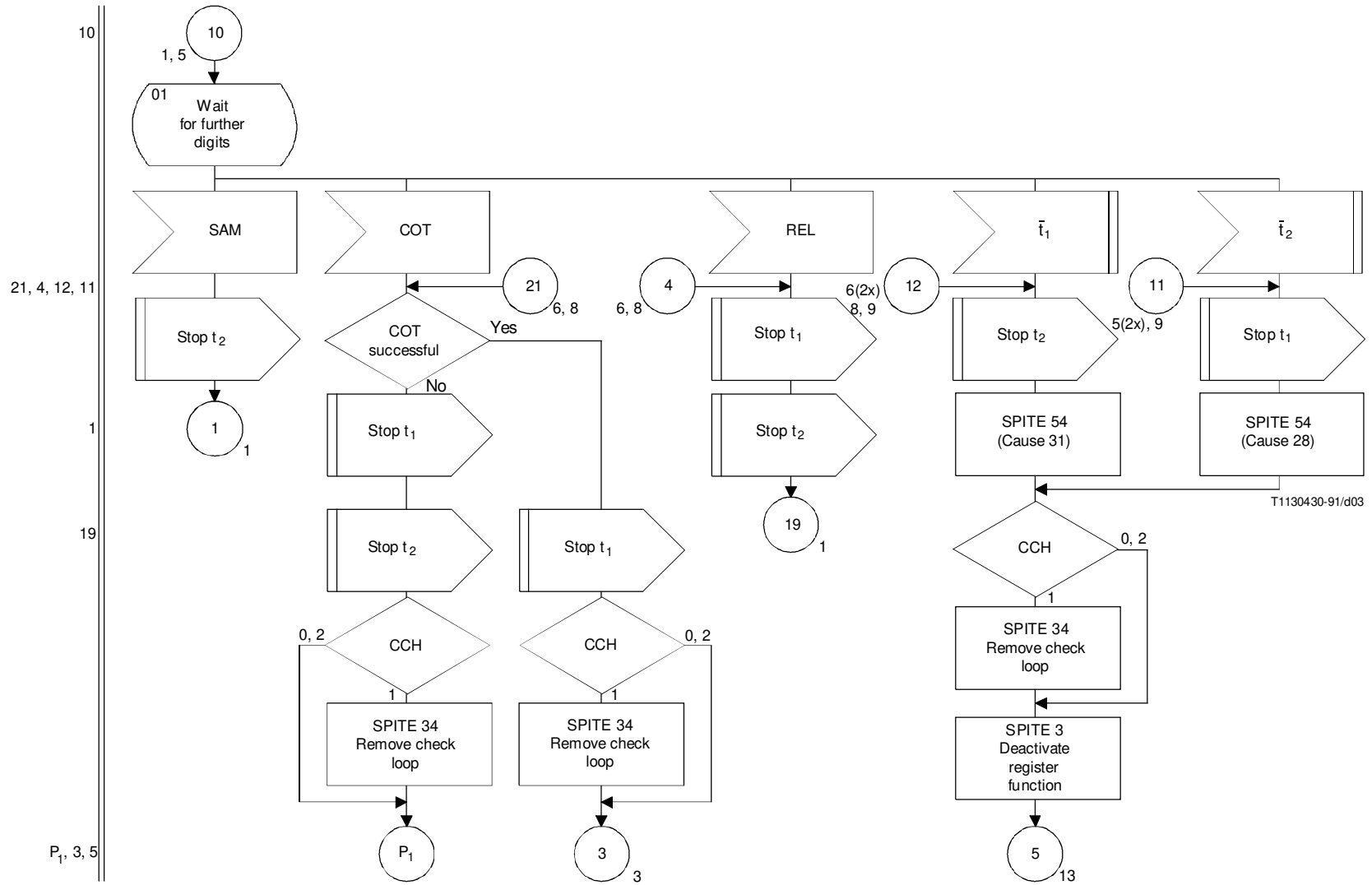

FIGURE 3/Q.617 (sheet 2 of 16)
Incoming Signalling System No. 7 (ISUP)

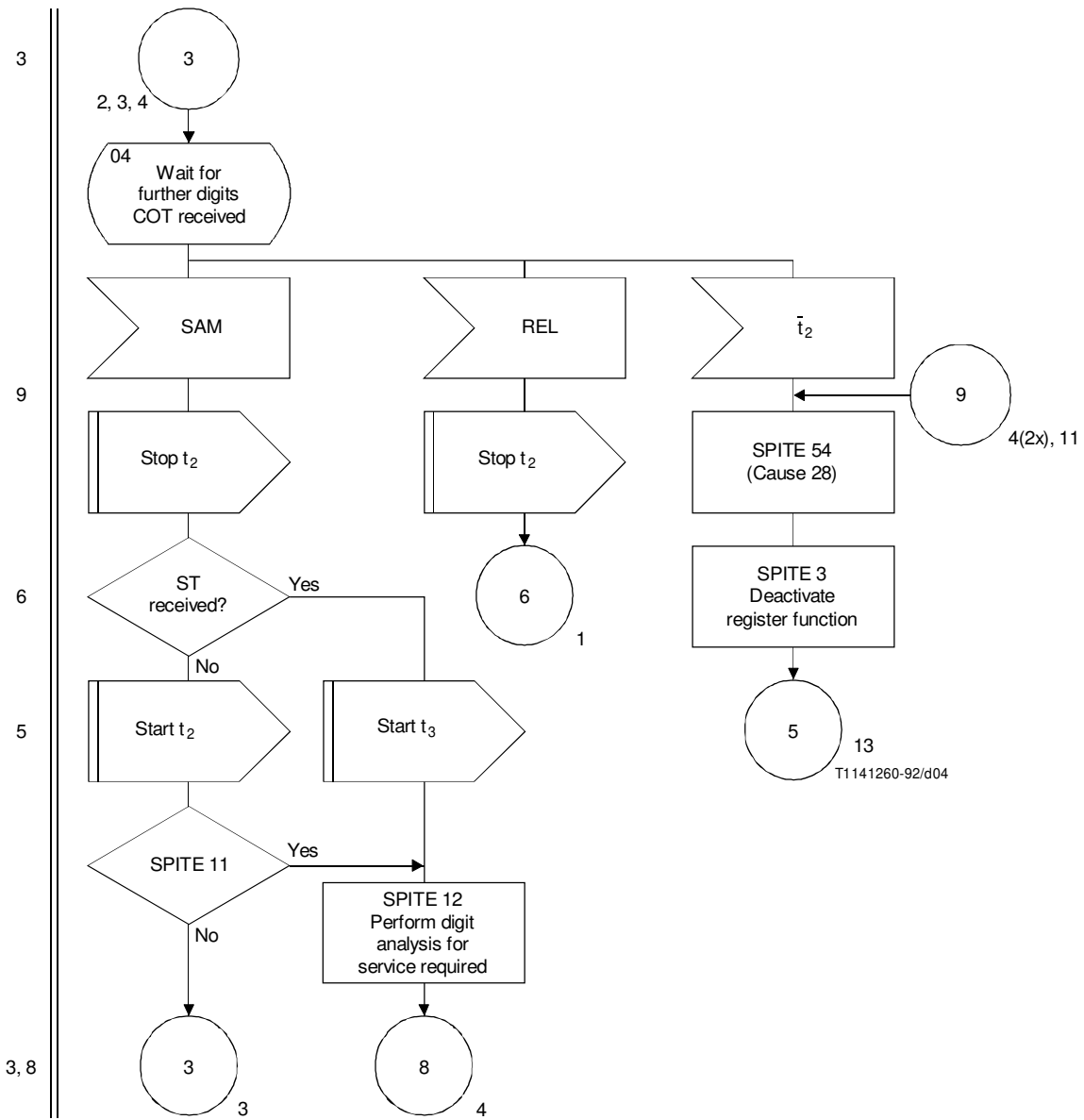

FIGURE 3/Q.617 (sheet 3 of 16)
Incoming Signalling System No. 7 (ISUP)

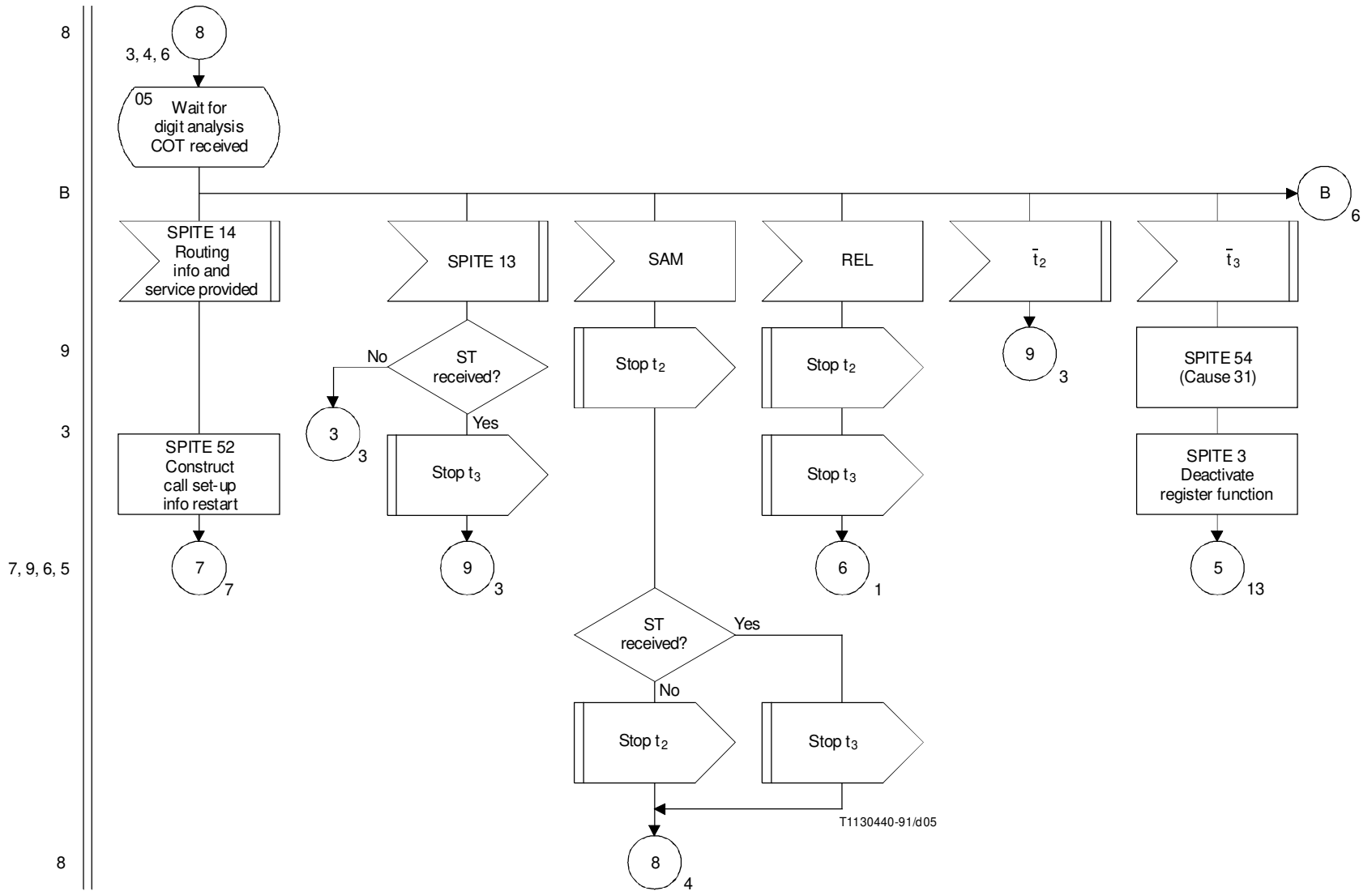

FIGURE 3/Q.617 (sheet 4 of 16)
Incoming Signalling System No. 7 (ISUP)

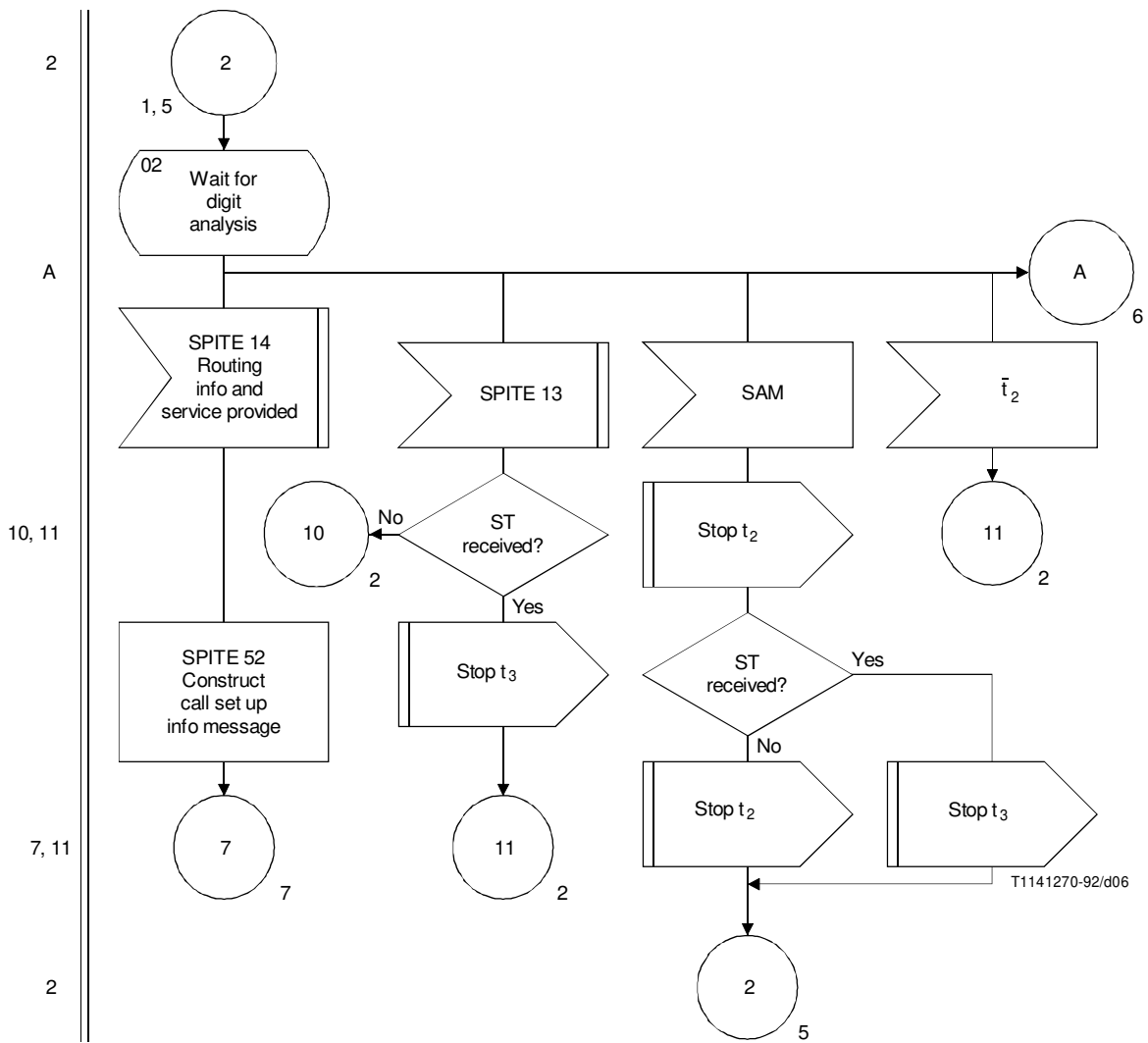

FIGURE 3/Q.617 (sheet 5 of 16)
Incoming Signalling System No. 7 (ISUP)

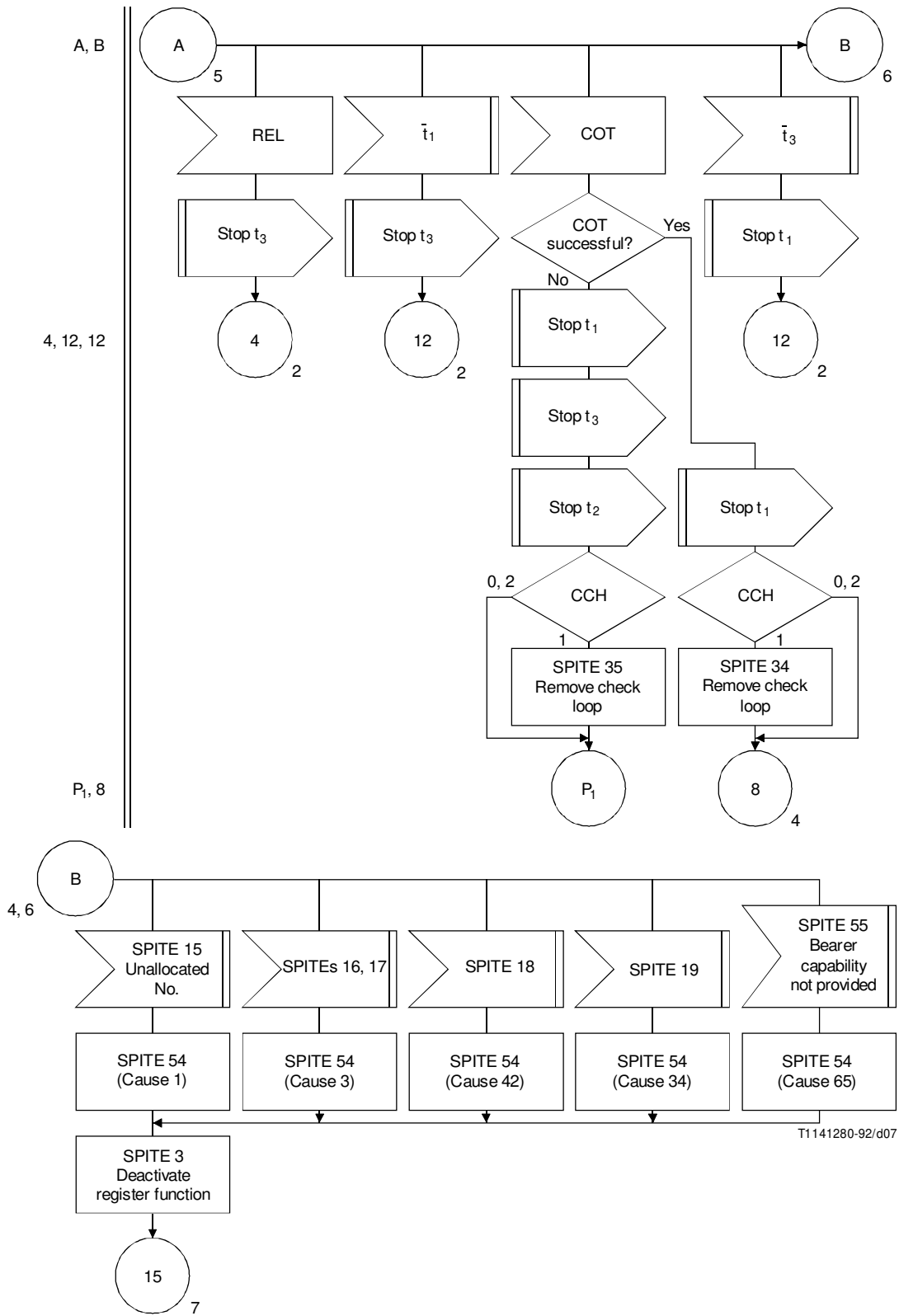
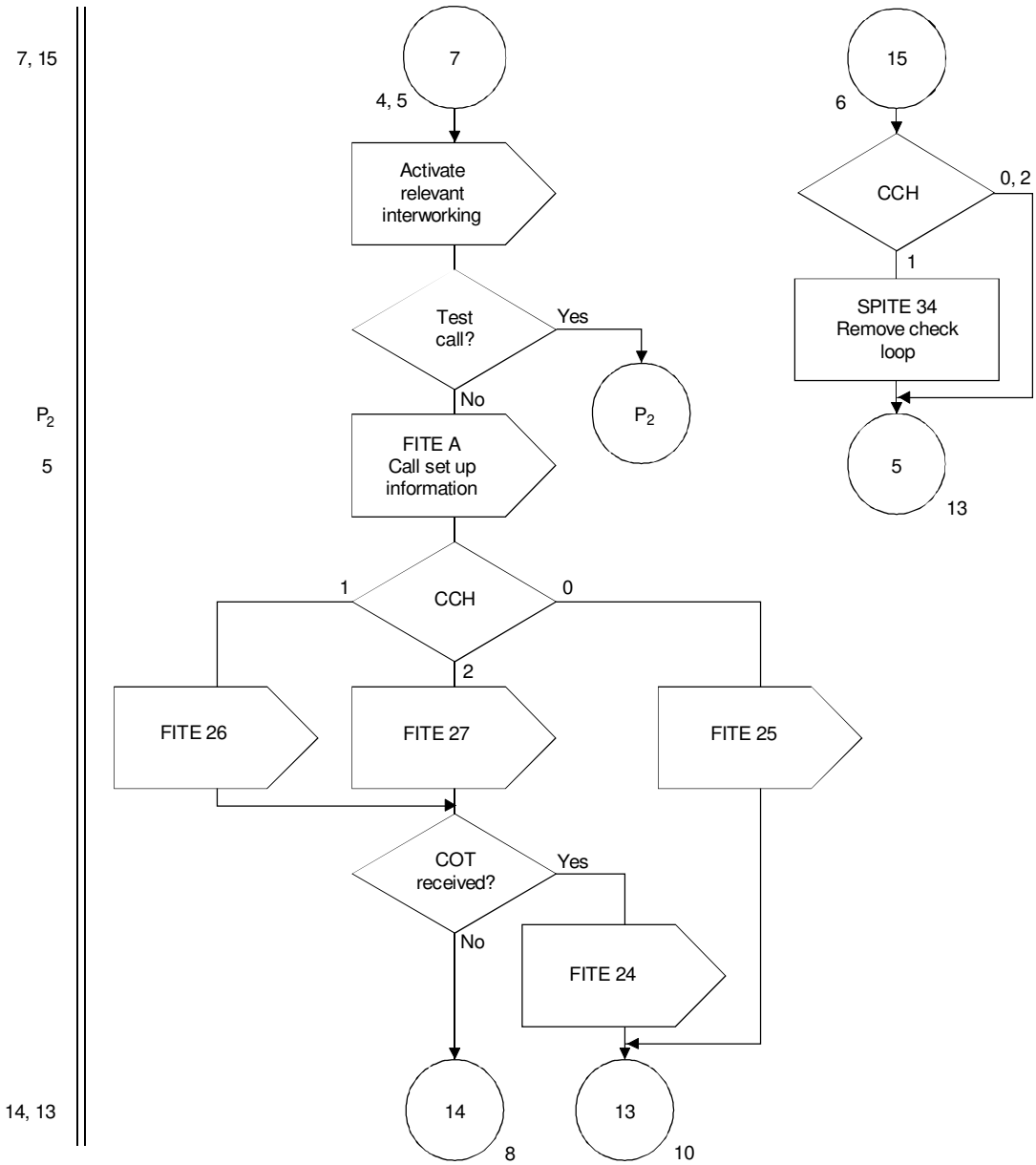
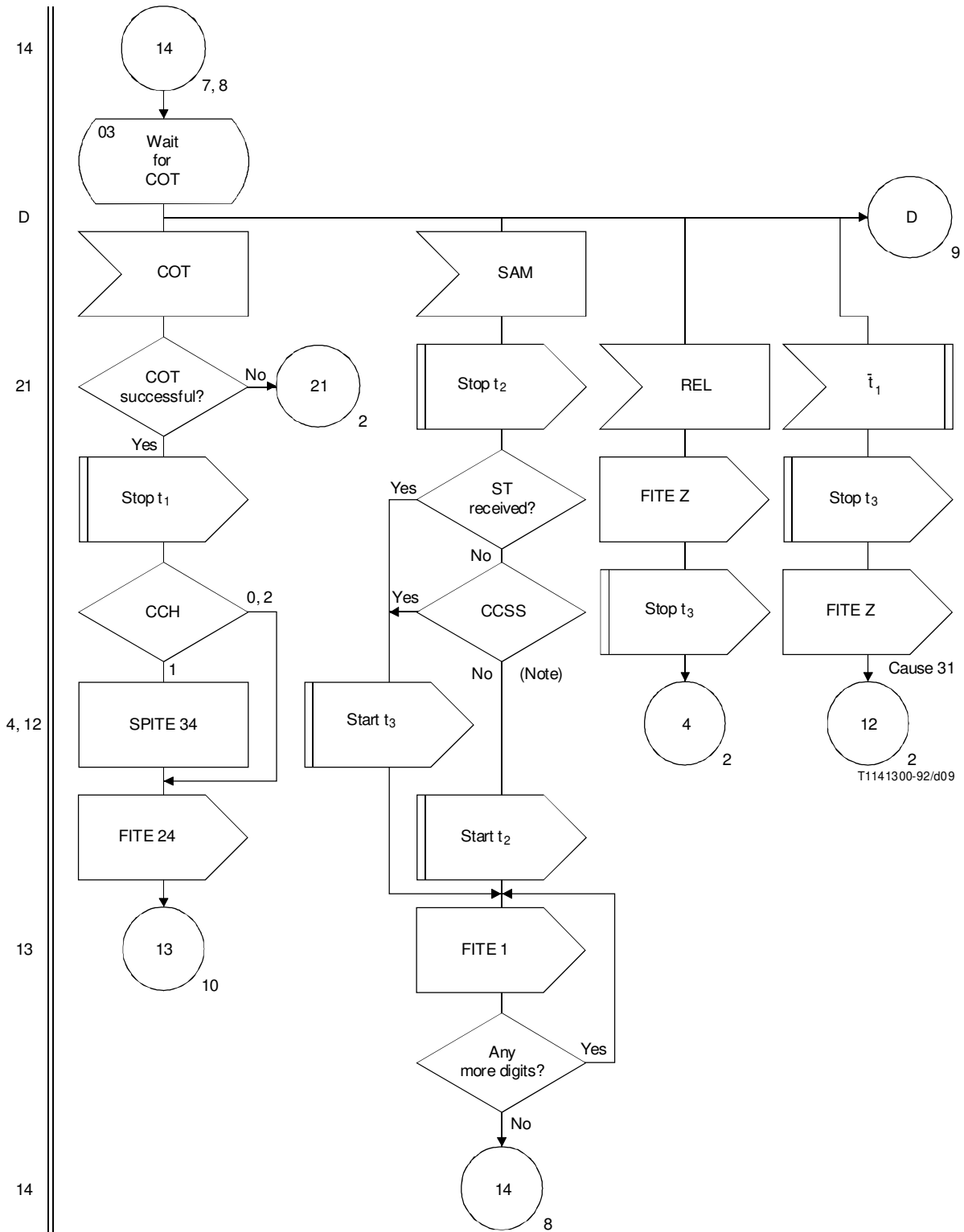

FIGURE 3/Q.617 (sheet 6 of 16)
Incoming Signalling System No. 7 (ISUP)



T1141290-92/d08

FIGURE 3/Q.617 (sheet 7 of 16)
Incoming Signalling System No. 7 (ISUP)



NOTE – Is outgoing link common channel signalling system?

FIGURE 3/Q.617 (sheet 8 of 16)
Incoming Signalling System No. 7 (ISUP)

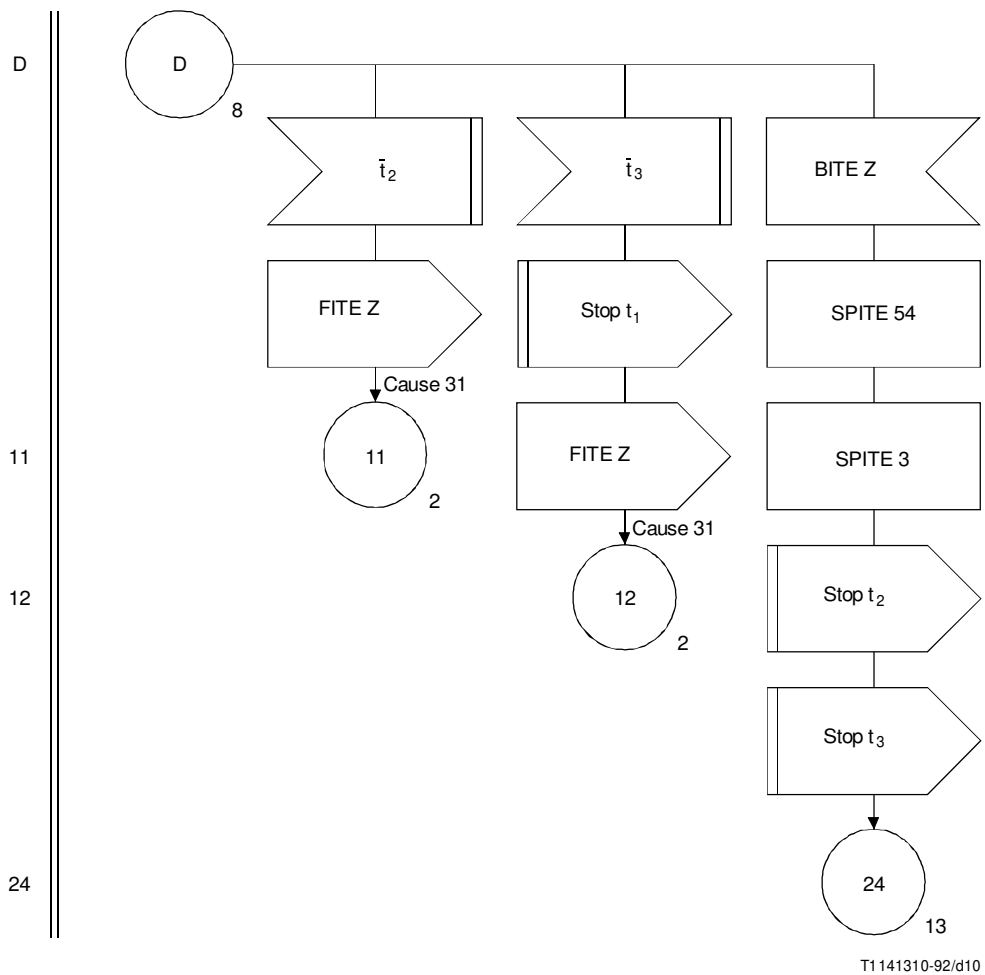
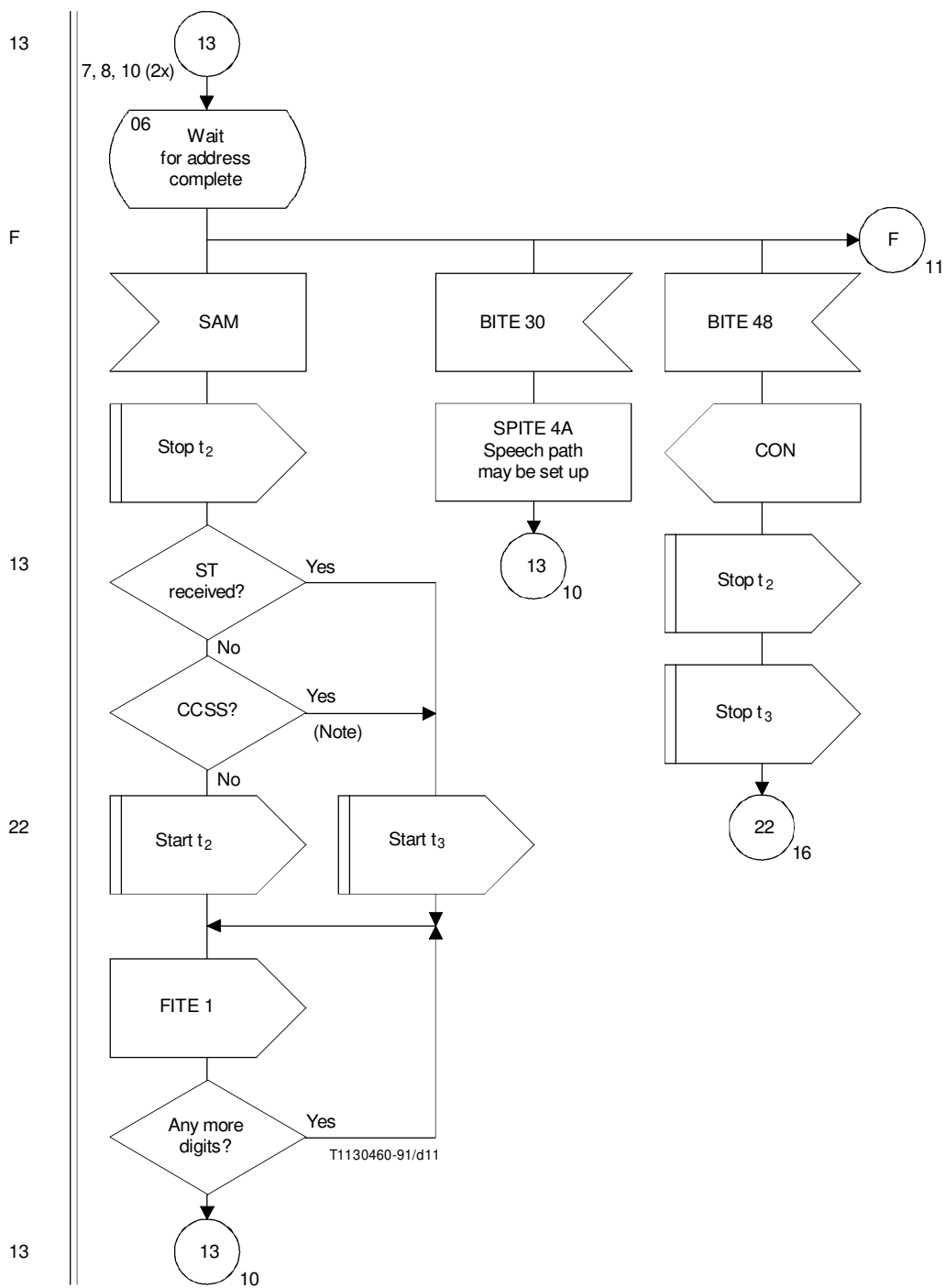

FIGURE 3/Q.617 (sheet 9 of 16)
Incoming Signalling System No. 7 (ISUP)



NOTE – Is outgoing link common channel signalling system?

FIGURE 3/Q.617 (sheet 10 of 16)
Incoming Signalling System No. 7 (ISUP)

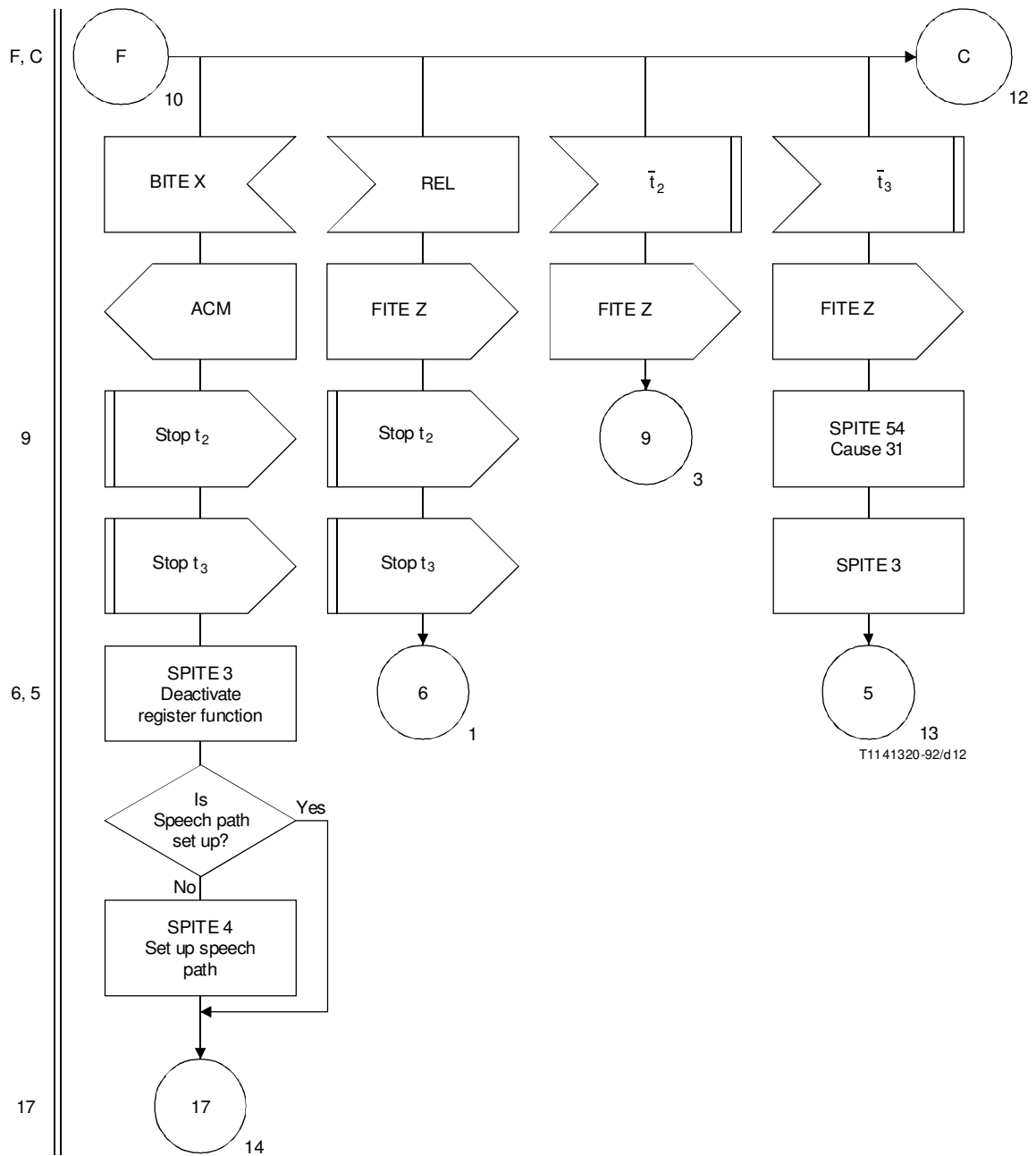

FIGURE 3/Q.617 (sheet 11 of 16)
Incoming Signalling System No. 7 (ISUP)

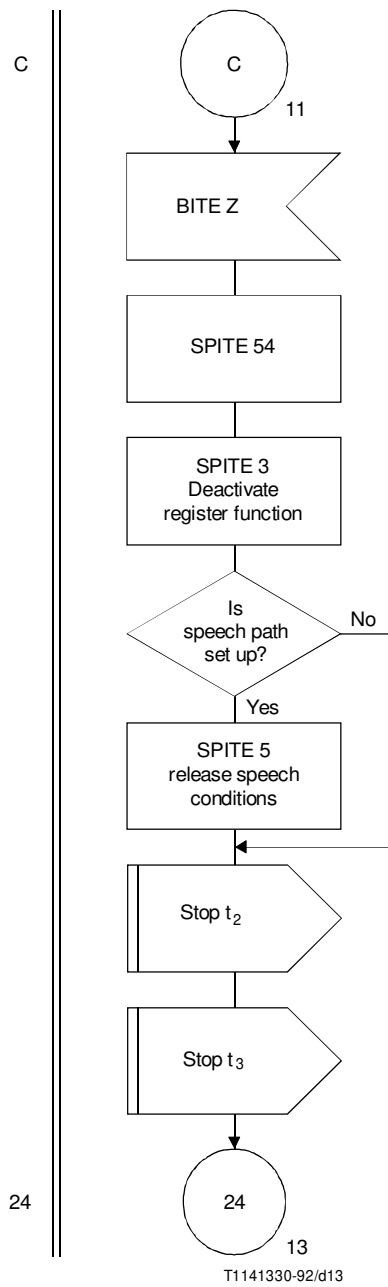

FIGURE 3/Q.617 (sheet 12 of 16)
Incoming Signalling System No. 7 (ISUP)

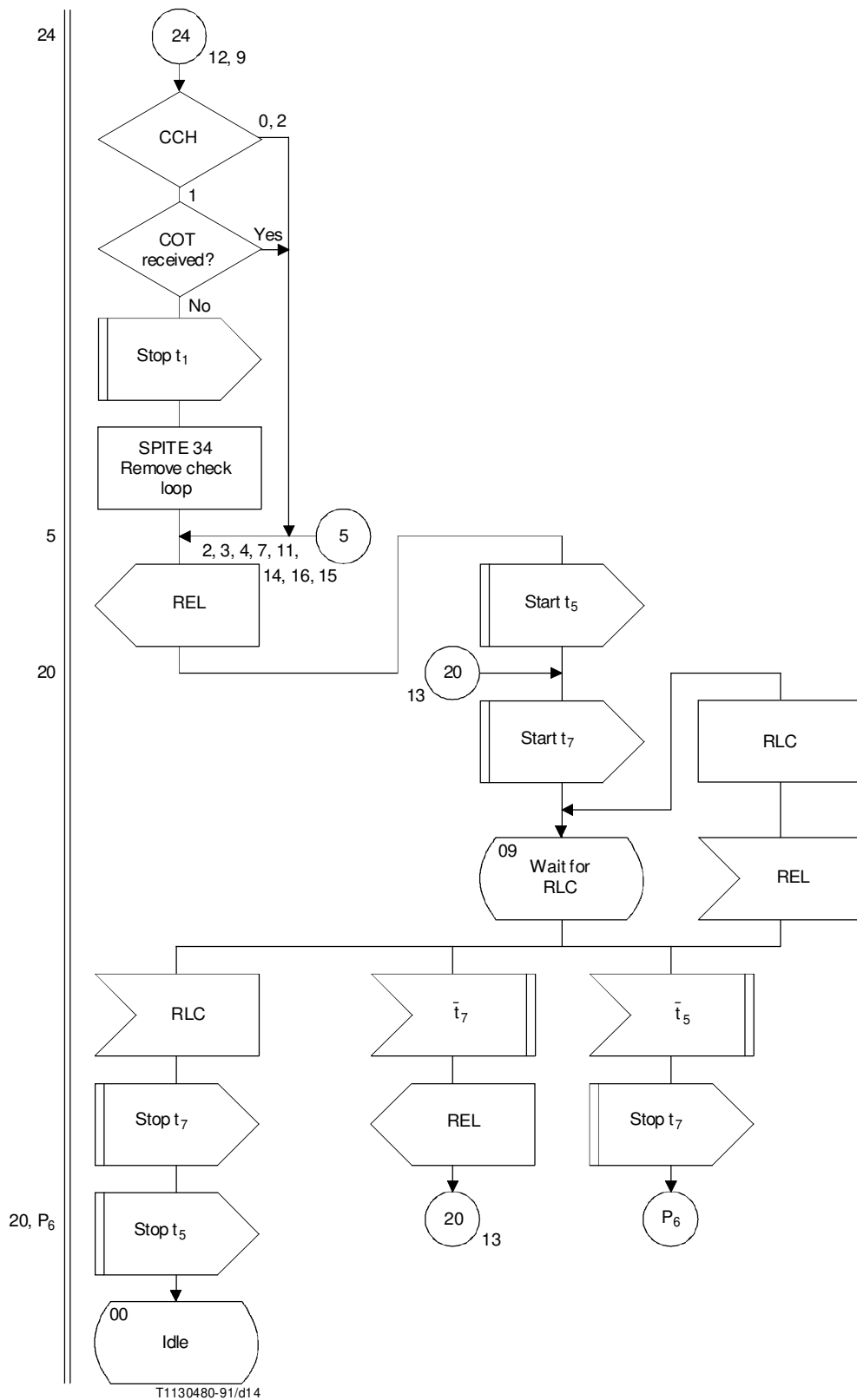

FIGURE 3/Q.617 (sheet 13 of 16)
Incoming Signalling System No. 7 (ISUP)

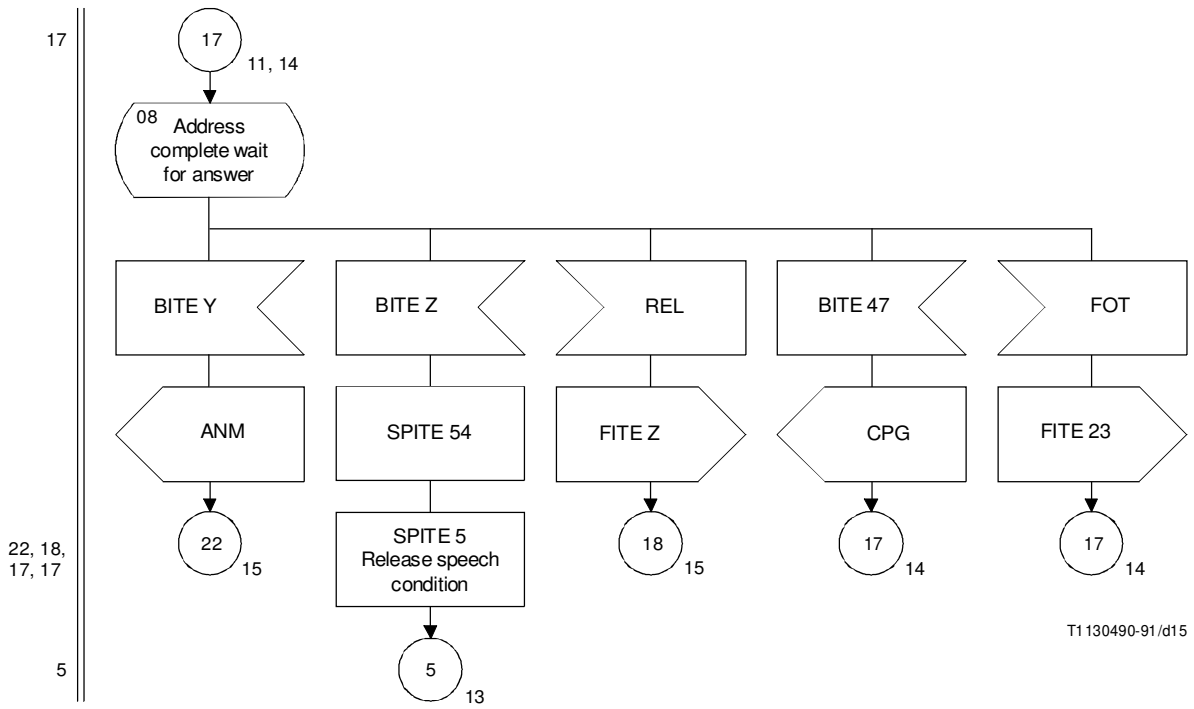

FIGURE 3/Q.617 (sheet 14 of 16)
Incoming Signalling System No. (ISUP)

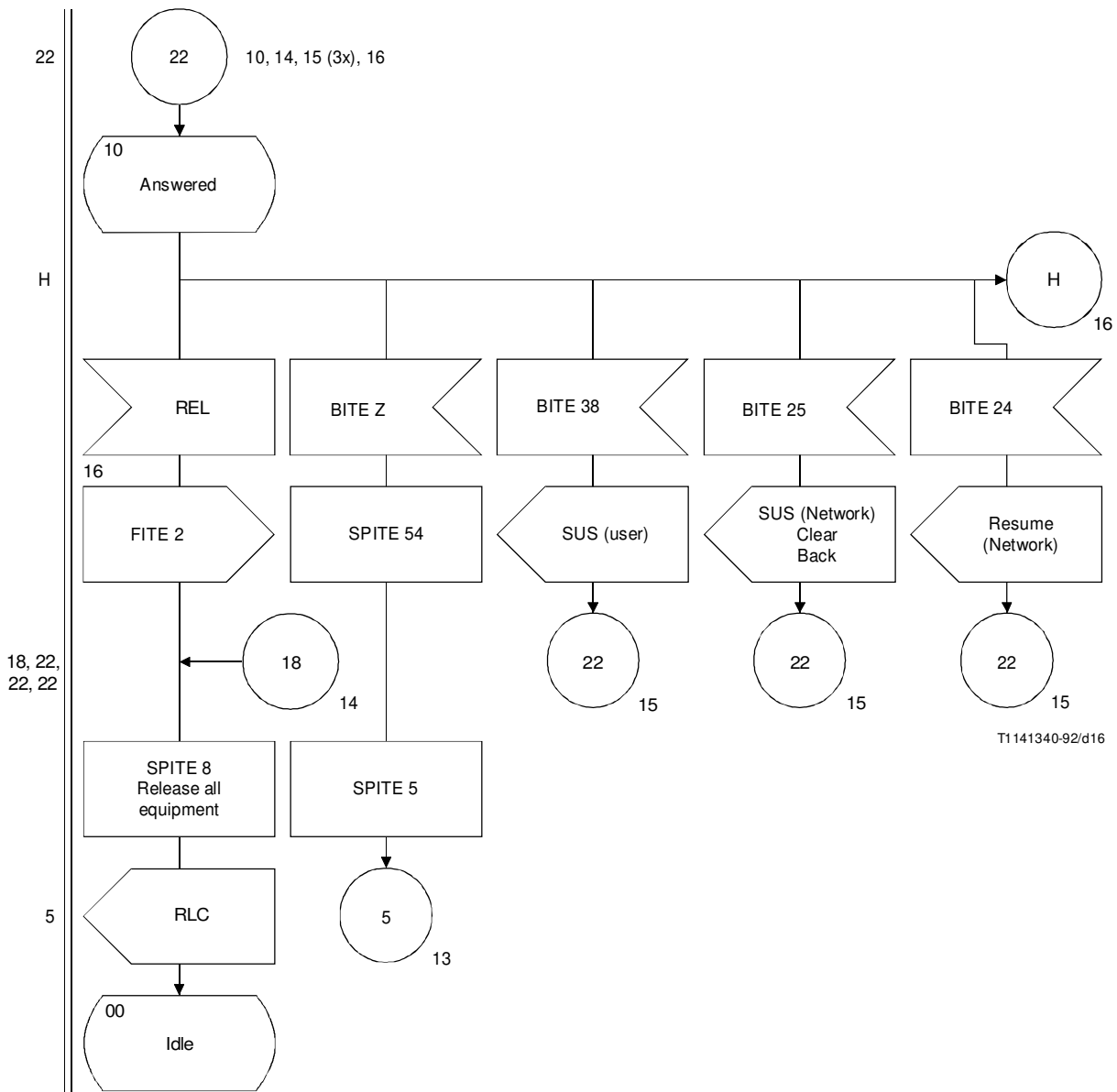

FIGURE 3/Q.617 (sheet 15 of 16)
Incoming Signalling System No. 7 (ISUP)

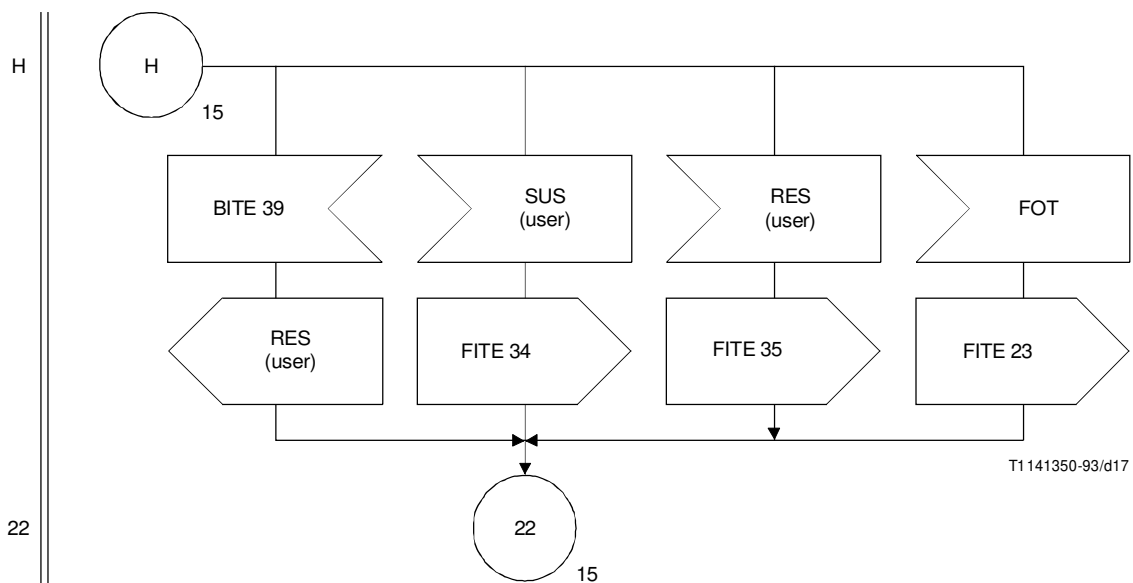

FIGURE 3/Q.617 (sheet 16 of 16)
Incoming Signalling System No. 7 (ISUP)