



INTERNATIONAL TELECOMMUNICATION UNION

ITU-T

TELECOMMUNICATION
STANDARDIZATION SECTOR
OF ITU

Q.1213

(03/93)

**GENERAL RECOMMENDATIONS ON TELEPHONE
SWITCHING AND SIGNALLING
INTELLIGENT NETWORK**

**GLOBAL FUNCTIONAL PLANE FOR
INTELLIGENT NETWORK CS-1**

ITU-T Recommendation Q.1213

(Previously "CCITT Recommendation")

FOREWORD

The ITU Telecommunication Standardization Sector (ITU-T) is a permanent organ of the International Telecommunication Union. The ITU-T is responsible for studying technical, operating and tariff questions and issuing Recommendations on them with a view to standardizing telecommunications on a worldwide basis.

The World Telecommunication Standardization Conference (WTSC), which meets every four years, established the topics for study by the ITU-T Study Groups which, in their turn, produce Recommendations on these topics.

ITU-T Recommendation Q.1213 was prepared by the ITU-T Study Group XI (1988-1993) and was approved by the WTSC (Helsinki, March 1-12, 1993).

NOTES

1 As a consequence of a reform process within the International Telecommunication Union (ITU), the CCITT ceased to exist as of 28 February 1993. In its place, the ITU Telecommunication Standardization Sector (ITU-T) was created as of 1 March 1993. Similarly, in this reform process, the CCIR and the IFRB have been replaced by the Radiocommunication Sector.

In order not to delay publication of this Recommendation, no change has been made in the text to references containing the acronyms "CCITT, CCIR or IFRB" or their associated entities such as Plenary Assembly, Secretariat, etc. Future editions of this Recommendation will contain the proper terminology related to the new ITU structure.

2 In this Recommendation, the expression "Administration" is used for conciseness to indicate both a telecommunication administration and a recognized operating agency.

© ITU 1993

All rights reserved. No part of this publication may be reproduced or utilized in any form or by any means, electronic or mechanical, including photocopying and microfilm, without permission in writing from the ITU.

CONTENTS

	<i>Page</i>
1	General..... 1
1.1	Scope of IN global functional plane for capability set 1 1
1.2	Role of SIBs in the global functional plane..... 1
1.3	CS-1 global functional plane model 1
1.4	Terminology 2
2	CS-1 service independent building blocks (SIBs) 2
2.1	Algorithm..... 3
2.2	Charge..... 4
2.3	Compare 7
2.4	Distribution..... 8
2.5	Limit..... 10
2.6	Log call information 12
2.7	Queue 14
2.8	Screen..... 17
2.9	Service data management..... 18
2.10	Status notification 20
2.11	Translate..... 23
2.12	User interaction 25
2.13	Verify 27
3	Basic call process..... 29
3.1	General 29
3.2	Points of initiation and points of return 30
3.3	BCP stage 1 description 31
4	Global service logic..... 33
5	Mapping of the service plane to the global functional plane 33

SUMMARY

IN capability set 1 (CS-1) is the first standardized stage of the intelligent network as an architectural concept for the creation and provision of telecommunication services. This Recommendation provides the intelligent network (IN) global functional plane (GFP) architecture for IN capability set 1 (CS-1). This Recommendation defines the IN GFP for CS-1 based on the general framework for IN GFP provided in Recommendation Q.1203, consistent with the scope of CS-1 defined in Recommendation Q.1211.

This Recommendation defines:

- the IN GFP model for CS-1 in terms of a subset of the general IN GFP model;
- identifications and definition of the 14 CS-1 service independent building-blocks (SIBs), including the basic call process (BCP) specialized SIB;
- the use of global service logic in CS-1.

Companion Recommendations include the Q.120x and Q.121x-Series of Recommendations.

GLOBAL FUNCTIONAL PLANE FOR INTELLIGENT NETWORK CS-1

(Helsinki, 1993)

1 General

The concepts for the intelligent network (IN) are embodied in the intelligent network conceptual model (INCM) as described in associated Recommendation I.312/Q.1201. The global functional plane (GFP) of the INCM is described in associated Recommendation I.329/Q.1203.

1.1 Scope of IN global functional plane for capability set 1

IN capability set 1 (CS-1) is the first standardized stage of the intelligent network as an architectural concept for the creation and provision of telecommunication services. This Recommendation provides the functional characteristics of the GFP associated specifically with CS-1. General GFP aspects are addressed in associated Recommendations I.312/Q.1201 and I.329/Q.1203.

The following functional characteristics are specific to CS-1 and are addressed in this Recommendation:

- CS-1 SIBs (Clause 2)

For CS-1, 13 service independent building blocks (SIBs) are specified (not including the BCP SIB discussed below). These represent the minimum set of SIBs required to define the CS-1 targeted services, identified in associated Recommendation Q.1211.
- BCP SIB (Clause 3)

For CS-1 the basic call process has been defined as a specialized SIB which provides the basic call capabilities. Nine points of initiation (POIs) for global service logic (GSL) interfaces have been specified. In addition, six points of return (PORs) for GSL interfaces have been specified.
- Plane to plane mapping (Clause 5)

The relationships between the service plane and the GFP are specified for CS-1.
- For CS-1, network time is assumed to be available to all SIBs in the GFP and it does not have to be passed through call instance data.
- Stage 1 SDL diagrams are provided for CS-1 SIBs only where the SDLs clarify the understanding of the SIB operation.

1.2 Role of SIBs in the global functional plane

SIBs are abstract representations of network capabilities that exist in an IN structured network. Their definition enforces the concept of service and technology independence by decoupling the services from the technology on which services are provided. The 13 SIBs defined in this Recommendation identify the network capabilities which will be available to service designers in a CS-1 IN structured network. Their use will provide valuable insight on how service creation will be facilitated in CS-n Recommendations.

1.3 CS-1 global functional plane model

The INCM described in Recommendation I.312/Q.1201 models the GFP as shown in Figure 1. The global functional plane models the network from a global, or a network wide, point of view. Contained in this view is the BCP SIB, including CS-1 POIs and PORs, the CS-1 SIBs, and the GSL, which describes how SIBs are chained together to describe service features.

This Recommendation specifies how the model can be used to fully define CS-1 service features in the GFP.

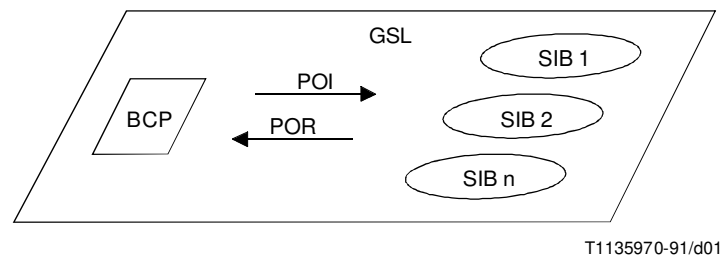

FIGURE 1/Q.1213
Global functional plane model

1.4 Terminology

The following terminology used in this Recommendation, is more fully defined in Recommendations I.329/Q.1203 and Q.1290:

CID	call instance data
CIDFP	call instance data field pointer
CLI	calling line identification
SSD	service support data

2 CS-1 service independent building blocks (SIBs)

The following list of SIBs have been identified as required to support the list of targeted CS-1 services and service features identified in Recommendation Q.1211:

- Algorithm
- Charge
- Compare
- Distribution
- Limit
- Log call information
- Queue
- Screen
- Service data management
- Status notification
- Translate
- User interaction
- Verify

The stage 1 SIB descriptions that follow reflect the understanding of the logical function of each SIB in its role of supporting CS-1 services and service features. The BCP, which is viewed as a specialized SIB, is described in 3.

An explanation of the format of the stage 1 SIB descriptions can be found in Recommendation I.312/Q.1203.

2.1 Algorithm

2.1.1 Definition

Applies a mathematical algorithm to data to produce a data result.

2.1.2 Operation

This SIB takes a specified call instance data and applies the specified mathematical algorithm to it to produce the corresponding data result.

It can be used to implement a simple arithmetic operation as incrementing a counter.

2.1.3 Potential service applications

- Mass calling
- Televoting

2.1.4 Input

2.1.4.1 Logical start

Indicates the logical start of execution for the SIB.

2.1.4.2 Service support data

- Type
Specifies the type of algorithm for this SIB. Two algorithms have been identified for CS-1:
 - a) increment;
 - b) decrement.
- Value
Specifies the amount to be used when applying the SIB (e.g. 1, 2, etc.).
- CIDFP-Algorithm
This CID field pointer specifies the call instance data to which the algorithm is to be applied.
- CIDFP-Error
This CID field pointer specifies where in output call instance data the error cause will be written.

2.1.4.3 Call instance data

- Identifier
The identifier is the data associated with the CIDFP-Algorithm upon which algorithm is to be applied.

2.1.5 Output

2.1.5.1 Logical end

- Success.
- Error.

2.1.5.2 Call instance data

- Identifier
Contains the resultant value after the SIB has completed.

- Error cause

Identifies the specific condition which caused an error during the operation of the SIB. The following errors have been identified for Algorithm:

- invalid type;
- invalid value.

2.1.6 Graphical representation

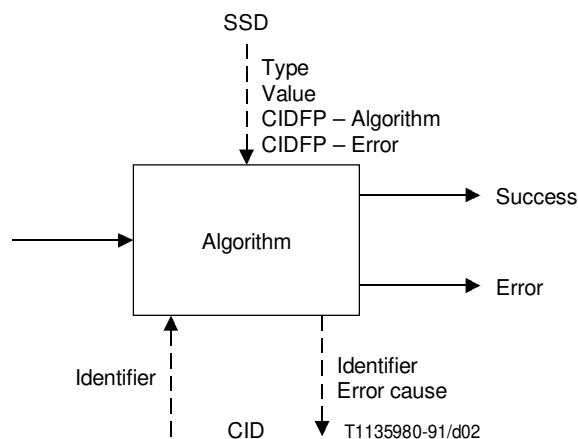

FIGURE 2/Q.1213

Algorithm SIB

2.2 Charge

2.2.1 Definition

Determine special charging treatment for the call, where special refers to any charging in addition to that normally performed by the basic call process.

In general, this involves identifying

- the resources for which charging is to occur;
- to where the charges are to be directed.

It should be noted that this SIB is not responsible for the subscriber billing process.

2.2.2 Operation

The charging information output by this SIB must be compatible with the charging and billing system of the network operator or service provider. However, this SIB does not define the format of the output nor identify all the types of information that an Administration will require for charging. Generation of bills will often be done off-line by the Administration's existing billing system.

The charge SIB is used for specific resource charging and may be invoked several times in one service/service feature instance.

Different simultaneous or consecutive call instances may charge the same account.

Typical resources for which charging can occur are:

- circuit-mode bearers;
- packet or messages;
- SRF resources, e.g. announcements, voice message storage, etc.;
- SCF usage (in units).

Typically, charging may be directed towards:

- a) the account identified by the CLI;
- b) the account identified by the called number (either the dialled number or the destination number);
- c) an account or credit card identified by the collected user information;
- d) the calling user's exchange accumulator;
- e) a payphone.

2.2.3 Potential service application

- Any service which requires specific IN charging.

2.2.4 Input

2.2.4.1 Logical start

Indicates the logical start of execution for the SIB.

2.2.4.2 Service support data

- Number of accounts to charge
- Account

Each account is specified by two parameters, as follows:

a) Number

Specifies one of the following:

1) CIDFP-Line

This CID field pointer specifies which call instance data is to be used as the line number to charge.

2) CIDFP-Account

This CID field pointer specifies which call instance data is to be used as the account number to charge.

3) Fixed account

Specifies an account number which is fixed for all call instances.

b) Percent (%)

Specifies the allocation of the total charge for this account. The sum of all allocations must equal 100 %.

- Resource type

Specifies the resource to be charged for (e.g. bearer type, announcement, SCF usage, etc.).

- Units

Specifies a premium value for the specified resource type.

- Service/service feature identifier

Specifies the service/service feature for which charging is to be applied.

- CIDFP-Pulse

This CID field pointer specifies which call instance data is used to identify pulse metering on the calling line.

- CIDFP-Error

This CID field pointer specifies where in output call instance data the error cause will be written.

2.2.4.3 Call instance data

- Line(s)

Specifies a line number for charging. This can be the calling line, the dialled number or a destination number.

- Account(s)

Specifies an account number for charging. This is an account number which was entered during the call such as a credit card or a calling card number.

- Pulse metering

When specified, indicates that pulse metering is associated with the calling line.

2.2.5 Output

2.2.5.1 Logical end

- 1) Success
- 2) Error

2.2.5.2 Call instance data

- Error cause

Identifies the specific condition which caused an error during the operation of the SIB. The following errors have been identified for Charge:

- invalid account to charge;
- invalid percentage allocation (> 100 , < 0);
- invalid sum of percentage allocations (not equal to 100);
- invalid service/service feature;
- invalid resource;
- invalid units;
- system fault – unable to write record.

2.2.6 Graphical representation

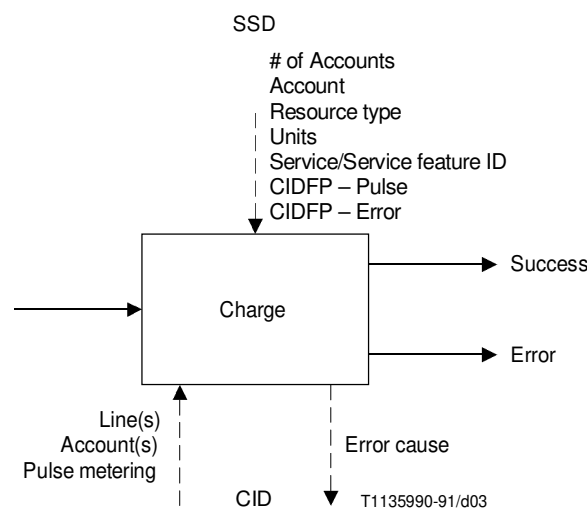

FIGURE 3/Q.1213

Charge SIB

2.3 Compare

2.3.1 Definition

Performs a comparison of an identifier against a specified reference value. Three results are possible:

- identifier is GREATER than the value;
- identifier is LESS than the value;
- identifier is EQUAL TO the value.

2.3.2 Operation

This SIB compares an identifier to a specified reference value. One of three logical outputs will result from this operation (e.g. <, >, or =). Other logical outputs can be formulated by combining two of the logical outputs together (e.g. < >, <=, or =>).

It can be used for:

- a) Comparing an identifier to a specified reference value. For instance, for checking that the current number of calls is less than the maximum number authorized.
- b) For checking the relationship of current network time to a customer specified time to perform time dependent decision. The comparison may be done on time of day (TOD), day of week (DOW), or day of year (DOY). The reference value is then the customer specified TOD, DOW or DOY.

2.3.3 Potential service applications

- Time dependent routing
- CCBS

2.3.4 Input

2.3.4.1 Logical start

Indicates the logical start of execution for the SIB.

2.3.4.2 Service support data

- Comparison type

Specifies the type of comparison to be performed. The following types have been identified:

- a) Identifier value – compare the identifier against the reference value.
- b) Time – compare network time to the reference value. Network time is specified as:
 - 1) time of day;
 - 2) day of week; or,
 - 3) day of year.

- CIDFP-Compare

This CID field pointer specifies which call instance data is to be used as the identifier.

- Reference value

Specifies the value against which the comparison will be made.

- CIDFP-Error

This CID field pointer specifies where in output call instance data the error cause will be written.

2.3.4.3 Call instance data

- Identifier

Specifies the data associated with the CIDFP-Compare (see SSD) which is to be compared to the reference value.

2.3.5 Output

2.3.5.1 Logical end

- GREATER THAN the value;
- LESS THAN the value;
- EQUAL TO the value;
- Error.

2.3.5.2 Call instance data

- Error cause

Identifies the specific condition which caused an error during the operation of the SIB. The following errors have been identified for Compare:

- invalid identifier;
- invalid reference value.

2.3.6 Graphical representation

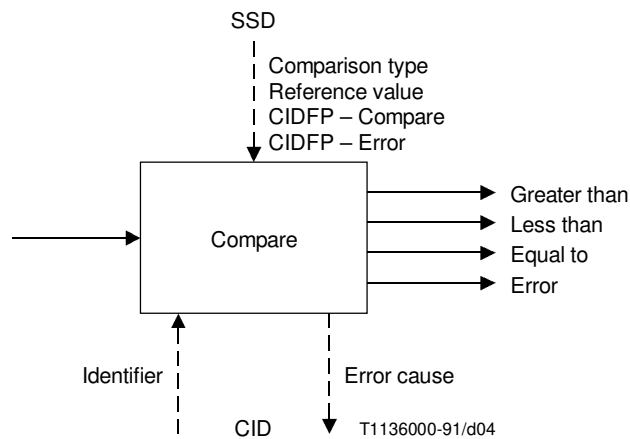

FIGURE 4/Q.1213

Compare SIB

2.4 Distribution

2.4.1 Definition

Distribute calls to different logical ends of the SIB based on user specified parameters.

2.4.2 Operation

This SIB distributes calls to its different logical ends based on a user identified algorithm. For example, calls could be distributed based on a percentage allocated to each logical end.

2.4.3 Potential service applications

- Mass calling;
- Televoting;
- Freephone.

2.4.4 Input

2.4.4.1 Logical start

Indicates the logical start of execution for the SIB.

2.4.4.2 Service support data

- Algorithm type
 - a) percentage;
 - b) sequential;
 - c) time of day;
 - d) day of week.

NOTE – Hierarchical call distribution may be realized through the use of multiple instances of the distribution SIB in conjunction with the status notification SIB.

- Number of logical ends

NOTE – Unlike most SSD, change of this value will effect the structure of the GSL this SIB is contained in.

- Algorithm parameters

If Type = Percentage

For each logical end

- percentage (sum over all paths must equal 100).

If Type = Sequential

None

If Type = Time of day

For each logical end

- begin time associated with this logical end;
- end time associated with this logical end.

All 24 hours of the day must be accounted for, with no overlap of time across logical ends.

If Type = Day of week

For each logical end

- all days of the week to be associated with this logical end.

All days of the week must be accounted for. No day may be associated with more than one logical end.

- CIDFP-Error

This CID field pointer specifies where in output call instance data the error cause will be written.

2.4.4.3 Call instance data

- None

2.4.5 Output

2.4.5.1 Logical end

- 1
- 2
- ...
- N [where N = number of logical ends (Item 1 of input SSD)]
- Error

2.4.5.2 Call instance data

- Error cause

Identifies the specific condition which caused an error during the operation of the SIB. The following errors have been identified for Distribution:

- invalid type;
- invalid percentage allocation ($> 100, < 0$);
- invalid sum of percentage allocations (not equal to 100);
- invalid number of logical ends;
- missing time period;
- overlap of the time across logical ends;
- missing days;
- overlap of days across logical ends.

2.4.6. Graphical representation

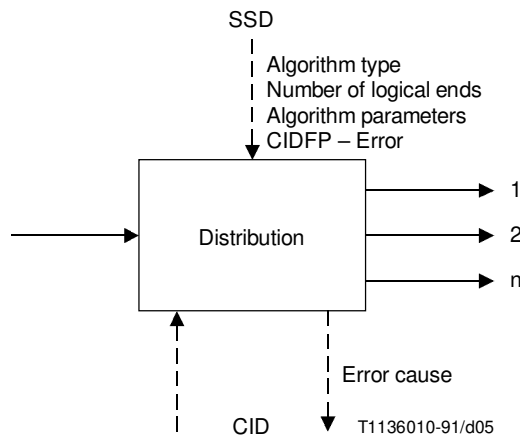

FIGURE 5/Q.1213
Distribution SIB

2.5 Limit

2.5.1 Definition

Limit the number of calls related to IN provided service features. Such limiting will be based on user specified parameters.

NOTE – This SIB is not used for network congestion management functions.

2.5.2 Operation

This SIB may be used to pass all or a fraction of all calls related to IN provided service features.

For example, calls may be passed

- for a specific duration (which may be infinite) at specific intervals;
- according to a counting algorithm (e.g. pass N calls out of P).

The limit SIB in conjunction with other SIBs (e.g. Compare) can provide the required functionality for time dependent call limiting (e.g. TOD).

2.5.3 Potential service applications

- Mass calling;
- Televoting;
- Freephone.

2.5.4 Input

2.5.4.1 Logical start

Indicates the logical start of execution for the SIB.

2.5.4.2 Service support data

- Type

Specifies the type of limiting to be performed. The following types have been identified:

- a) pass calls for (S) seconds out of every (Q) seconds;
- b) pass (N) calls out of (P) calls.

- Parameters

Specifies the parameters associated with the SSD type selected above:

- 1) S duration;
- 2) Q interval;
- 3) P counter interval;
- 4) N number of calls.

- CIDFP-File

This CID field pointer specifies where the current limit count is located.

- CIDFP-Error

This CID field pointer specifies where in output call instance data the error cause will be written.

2.5.4.3 Call instance data

- File

Identifies the data associated with CIDFP-File which specifies the current count of calls.

2.5.5 Output

2.5.5.1 Logical end

- Pass;
- No pass;
- Error.

2.5.5.2 Call instance data

- Error cause

Identifies the specific condition which caused an error during the operation of the SIB. The following errors have been identified for Limit:

- a) invalid type;
- b) invalid parameter.

2.5.6 Graphical representation

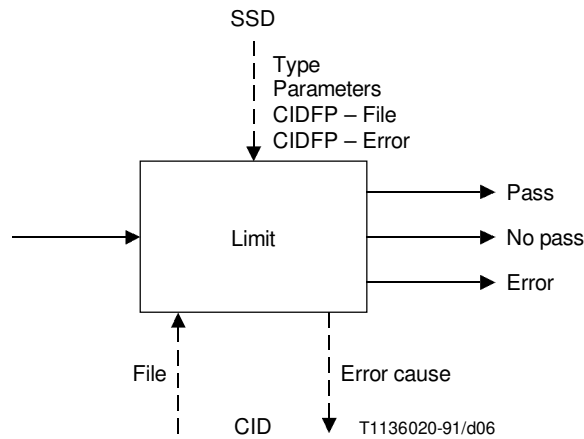

FIGURE 6/Q.1213

Limit SIB

2.6 Log call information

2.6.1 Definition

Log detailed information for each call into a file. The collected information may be used by management services (e.g. statistics, etc.) and not by call-related services.

2.6.2 Operation

This SIB logs (or writes) call related information to a specified file. The type of call-related information to be logged will be identified by service support data. Each instance of this SIB will cause the recording of the specified CID information.

2.6.3 Potential service applications

- All services

2.6.4 Input

2.6.4.1 Logical start

Indicates the logical start of execution for the SIB.

2.6.4.2 Service support data

- CIDFP-Log

These CID field pointers specify which call instance data are to be used as identifiers. CIDFP-Log can include:

- a) call attempt time;
- b) call stop time;
- c) call connect time;
- d) dialled number;
- e) destination number;

- f) additional dialled number (e.g. credit card number, etc.);
 - g) calling line identification;
 - h) time in queue;
 - i) bearer capability;
 - j) error causes;
 - k) any other CID.
- Log file indicator
Specifies the log file where the value of the identifier is to be logged.
 - CIDFP-Error
This CID field pointer specifies where in output call instance data the error cause will be written.

2.6.4.3 Call instance data

- Identifier(s)
Specifies the data associated with the CIDFP-Log (see SSD) which is to be logged.

2.6.5 Output

2.6.5.1 Logical end

- Success (information written);
- Error.

2.6.5.2 Call instance data

- Error cause

Identifies the specific condition which caused an error during the operation of the SIB. The following errors have been identified for Log call information:

- invalid identifier;
- invalid log file indicator.

2.6.6 Graphical representation

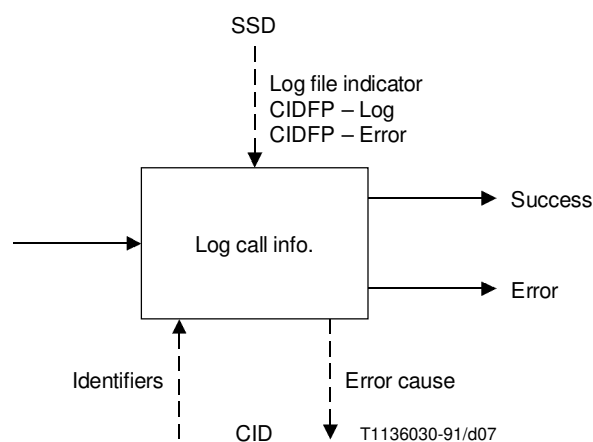

FIGURE 7/Q.1213
Log call information SIB

2.7 Queue

2.7.1 Definition

Provide sequencing of IN calls to be completed to a called party.

2.7.2 Operation

This SIB provides all the processing needed to provide queuing for a call, and will specifically:

- pass the call if resources are available;
- queue the call;
- play announcements to caller on queue;
- when resources become available, dequeue the call.

2.7.3 Potential service application

- All IN services which use call queuing service feature.

2.7.4 Input

2.7.4.1 Logical start

Indicates the logical start of execution for the SIB.

2.7.4.2 Service support data

- Max active
Specifies the maximum number of active calls allowed for the resource.
- Max number
Specifies the maximum number of calls allowed on queue at a given time.
- Max time
Specifies the maximum time the call may remain on the queue.
- Announcement parameters
Specify the control values for announcements. The control values which can be specified are:
 - Announcement ID specifies which announcement is to be sent;
 - Repetition requested specifies if the announcement is to be repeated;
 - Repetition interval specifies the delay period in seconds between repetitions;
 - Maximum repetitions specifies the maximum number of times the announcement will be repeated.
- CIDFP-Resource
This CID field pointer specifies which call instance data identifies the resource.
- CIDFP-Error
This CID field pointer specifies where in output call instance data the error cause will be written.

2.7.4.3 Call instance data

- Call reference
Identifies the specific call which is a candidate for queuing.
- Resource
Specifies the data associated with the CIDFP-Resource which identifies the resource for which the call will be queued.

2.7.5 Output

2.7.5.1 Logical end

- 1) Resource available;
- 2) Call party abandon;
- 3) Queue timer expiry;
- 4) Queue full;
- 5) Error.

2.7.5.2 Call instance data

- Time spent in queue

Identifies the total time that a particular call was queued.

- Error cause

Identifies the specific condition which caused an error during the operation of the SIB. The following errors have been identified for Queue:

- a) invalid Max active;
- b) invalid Max number;
- c) invalid Max time;
- d) invalid announcement parameters;
- e) invalid call reference.

2.7.6 Graphical representation

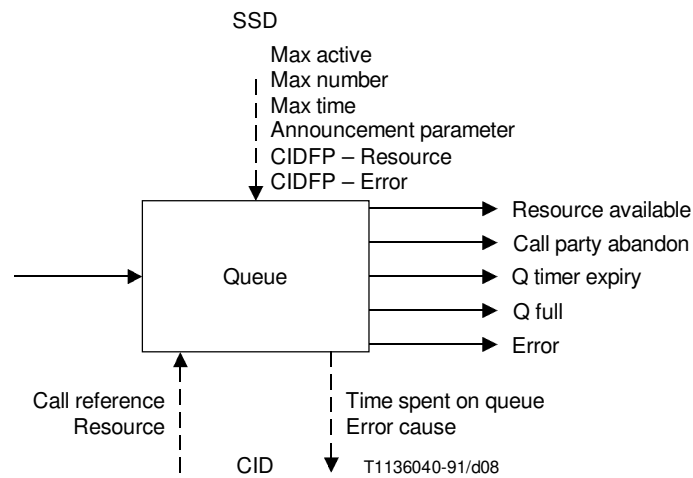

FIGURE 8/Q.1213

Queue SIB

2.7.7 SDL Diagram

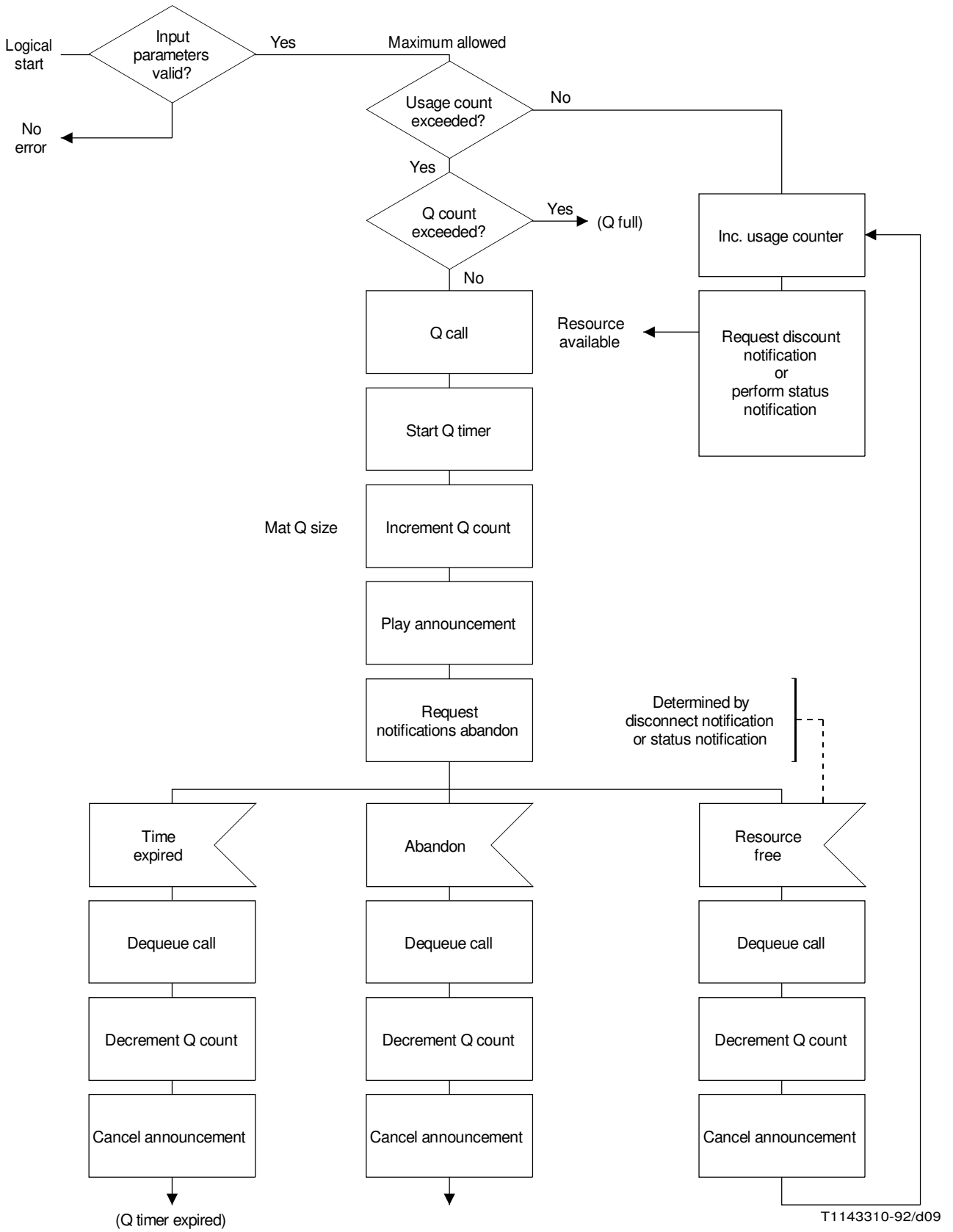

FIGURE 9/Q.1213
Queue SIB stage 1

2.8 Screen

2.8.1 Definition

Perform a comparison of an identifier against a list to determine whether the identifier has been found in the list.

2.8.2 Operation

This SIB takes the appropriate identifier and determines whether or not it is contained within the list identified by the SIB support data. A “Match” condition results if the identifier has been found on the list.

Examples using the screen SIB are:

- for verifying a user ID or PIN;
- for terminating or originating call screening based on a network address.

Multiple instances of the screen SIB, in conjunction with other SIBs, like Translate and Compare, may result in more complex screening capabilities.

2.8.3 Potential service applications

- Selective call forward on busy/ don't answer;
- Originating call screening;
- Terminating call screening;
- Security screening;
- Account card calling;
- Credit card calling.

2.8.4 Input

2.8.4.1 Logical start

Indicates the logical start of execution for the SIB.

2.8.4.2 Service support data

- Screen list indicator
The screen list indicator identifies the screen data to be used.
- CIDFP-Screen
This CID field pointer specifies which call instance data is to be used as the identifier.
- CIDFP-Error
This CID field pointer specifies where in output call instance data the error cause will be written.

2.8.4.3 Call instance data

- Identifier
The identifier is the data associated with the CIDFP-Screen (see SSD) which is to be screened against the screen data.

2.8.5 Output

2.8.5.1 Logical end

- Match [= on the list];
- No match;
- Error.

2.8.5.2 Call instance data

- Error cause

Identifies the specific condition which caused an error during the operation of the SIB. The following errors have been identified for Screen:

- invalid identifier;
- invalid screen list.

2.8.6 Graphical representation

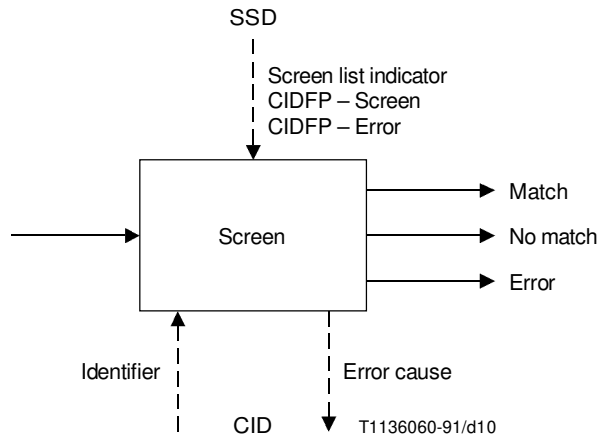

FIGURE 10/Q.1213

Screen SIB

2.9 Service data management

2.9.1 Definition

Enables end user specific data to be replaced, retrieved, incremented, or decremented.

2.9.2 Operation

This SIB performs the appropriate actions, i.e. replace, retrieve, increment, or decrement information stored within the network. For example, this SIB could be used to retrieve or replace a customer's call forwarding number.

2.9.3 Potential service application

- Call forwarding;
- Customer profile management.

2.9.4. Input

2.9.4.1 Logical start

Indicates the logical start of execution for the SIB.

2.9.4.2 Service support data

- File indicator
Specifies the subscriber data file to be used.

- Action

Specifies the operation to be performed on the subscriber data. The following actions are allowed:

- a) Replace – Replace the existing data element in the subscriber file specified by the element indicator with new data specified by the information value.
- b) Retrieve – Copy the data element specified by the element indicator and place it in the output CID called data retrieved.
- c) Increment – Increase the value of the data element in the subscriber file specified by the element indicator by the amount indicated by the Inc/Dec value.
- d) Decrement – Decrease the value of the data element in the subscriber file specified by the element indicator by the amount indicated by the Inc/Dec value.

- Element indicator

Specifies the data element in the subscriber data file upon which the action is to be performed. This optional data parameter is only required when the field to be acted upon is constant for all call instances (e.g. changing a call forwarding number). A “null” in this SSD field indicates that the element indicator can vary and its value must be provided through call instance data.

- Inc/Dec value

Specifies the amount by which the element indicator is to be incremented or decremented.

- CIDFP-Info

This CID field pointer specifies which call instance data is to be used as the information value.

- CIDFP-Element

This CID field pointer specifies which call instance data is to be used as the element indicator. If the element indicator is to be specified by the SSD, then this CID field pointer will not be used by the SIB.

- CIDFP-Retrieve

This CID field pointer specifies where in call instance data the retrieved data element is to be written.

- CIDFP-Error

This CID field pointer specifies where in output call instance data the error cause will be written.

2.9.4.3 Call instance data

- Information value

Specifies the new value for the subscriber data. This data is passed to this SIB from the user interaction SIB using the output CID parameter called collected data.

- Element indicator

Specifies the data element in the subscriber data file upon which the action is to be performed. This optional data parameter is only required when multiple data elements in the subscriber data file can be changed (e.g. in the case of an abbreviated dialling list).

2.9.5 Output

2.9.5.1 Logical end

- Success (record written or retrieved);
- Error.

2.9.5.2 Call instance data

- Data retrieved
Specifies the data element retrieved.
- Error cause
Identifies the specific condition which caused an error during the operation of the SIB. The following errors have been identified for Service data management:
 - a) invalid file indicator;
 - b) invalid action;
 - c) invalid element indicator;
 - d) invalid information value;
 - e) invalid Inc/Dec value.

2.9.6 Graphical representation

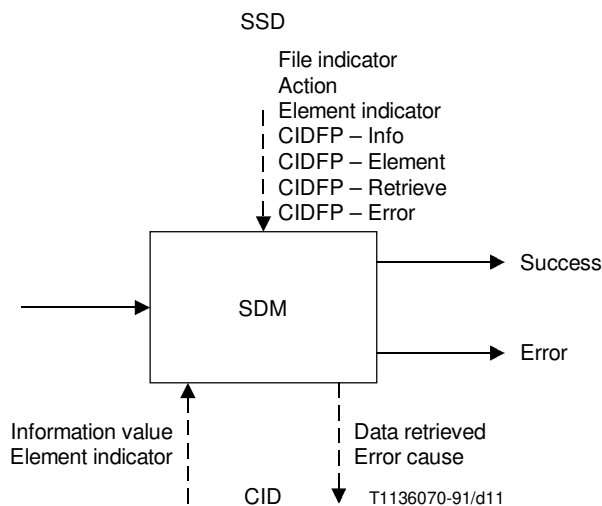

FIGURE 11/Q.1213
Service data management SIB

2.10 Status notification

2.10.1 Definition

Provide the capability of inquiring about the status and/or status changes of network resources.

2.10.2 Operation

There are four types of status notification requests:

- Poll resource status – return the current status of the resource.
- Wait for status – wait until the resource assumes the desired status unless the resource is already in the desired status.
- Initiate continuous monitor – monitor and record the changes in busy/idle status; Subsequent monitor – return all the changes in status for the resource or other events as required.
- Cancel continuous monitor.

“Poll resource status” status notification could be used to determine if the destination address is busy or idle. In the busy case, “wait for status” status notification could be used to notify service logic when the destination address becomes idle. “Initiate continuous monitor” status notification could be needed to create a resource history file.

2.10.3 Potential service applications

- CCBS;
- Call distribution;
- Freephone;
- Call transfer.

2.10.4 Input

2.10.4.1 Logical start

Indicates the logical start of execution for the SIB.

2.10.4.2 Service support data

- Type

Specifies the type of operation for this SIB. Four types have been identified:

- a) poll resource status;
- b) wait for status;
- c) initiate continuous monitor;
- d) cancel continuous monitor.

- Resource

Specifies the particular entity to be monitored. The following resources can be monitored:

- 1) lines;
- 2) trunks.

- Timer

Specifies the maximum amount of time to monitor the resource. If the value of timer is “null” no time limit is specified. This SSD is not used if the type is set to “poll resource status” or “cancel continuous monitor”.

- Status notification file indicator

Specifies the file where the current resource status is to be logged. If a “null” value is specified the resource status will not be logged. This SSD is not used if type is set to “cancel continuous monitor”.

- Resource status

Specifies the desired status of the resource being monitored. This SSD is only used when the type is set to “wait for status”. Valid resource statuses are:

- a) busy;
- b) idle.

- CIDFP-Status

This CID field pointer specifies where in call instance data that the resultant status of the resource is to be written.

- CIDFP-Error

This CID field pointer specifies where in output call instance data the error cause will be written.

2.10.4.3 Call instance data

- None

2.10.5 Output

2.10.5.1 Logical end

- Success
Poll resource status – present status returned.
Wait for status – line or resource has assumed the given status.
Initiate continuous monitor – continuous monitor initiated.
Cancel continuous monitor – continuous monitor terminated.
- Timer expiry (only used with “wait for status”);
- Error.

2.10.5.2 Call instance data

- Status
Specifies the current status of the resource.
- Error cause
Identifies the specific condition which caused an error during the operation of the SIB. The following errors have been identified for Status notification:
 - a) invalid type;
 - b) invalid resource;
 - c) invalid timer;
 - d) invalid file indicator;
 - e) invalid resource status.

2.10.6 Graphical representation

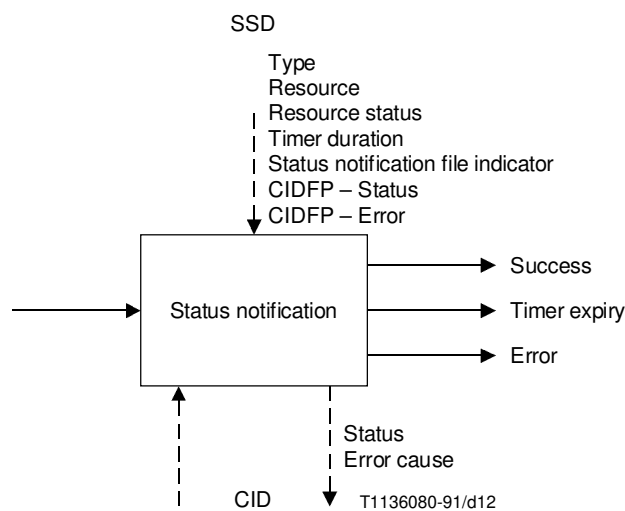

FIGURE 12/Q.1213

Status notification SIB

2.11 Translate

2.11.1 Definition

Determines output information from input information.

2.11.2 Operation

This SIB translates input information and provides output information, based on the various other input parameters. Parameters provided identify which file should be scanned for the translation. Translation can be based on either input information only, or on input information and the CLI.

For example, this SIB could be used for modifying input information (for instance, dialled digits) into a standard numbering plan upon which network routing is based.

In conjunction with other SIBs, like compare, the translate SIB can provide the required functionality for time dependant routing.

2.11.3 Potential service applications

- Freephone;
- User-defined routing;
- VPN;
- UPT;
- Abbreviated dialling;
- Selective call forwarding on busy/don't answer;
- Call forwarding;
- Call transfer.

2.11.4 Input

2.11.4.1 Logical start

Indicates the logical start of execution for the SIB.

2.11.4.2 Service support data

- Type
Specifies the mode of operation for this SIB. Three modes have been identified:
 - a) one number to one number;
 - b) one number to more than one number;
 - c) IA5 string to one number.
- File indicator
Specifies where the translation data file is located.
- CIDFP-CLI
This CID field pointer specifies the calling line identification.
- CIDFP-Info
This CID field pointer specifies which call instance data is to be used as the information.
- CIDFP-Translated
This CID field pointer specifies where in call instance data that the translated data element is to be written.
- CIDFP-Error
This CID field pointer specifies where in output call instance data the error cause will be written.

2.11.4.3 Call instance data

- CLI
Specifies the calling line identification.
- Information
Specifies the data to be translated.

2.11.5 Output

2.11.5.1 Logical end

- Success;
- Error.

2.11.5.2 Call instance data

- Translated data
Specifies the data element(s) resulting from the translation.
- Error cause
Identifies the specific condition which caused an error during the operation of the SIB. The following errors have been identified for Translate:

Identifies the specific condition which caused an error during the operation of the SIB. The following errors have been identified for Translate:

- invalid type;
- invalid file indicator;
- invalid information;
- invalid CLI;
- translation not available.

2.11.6 Graphical representation

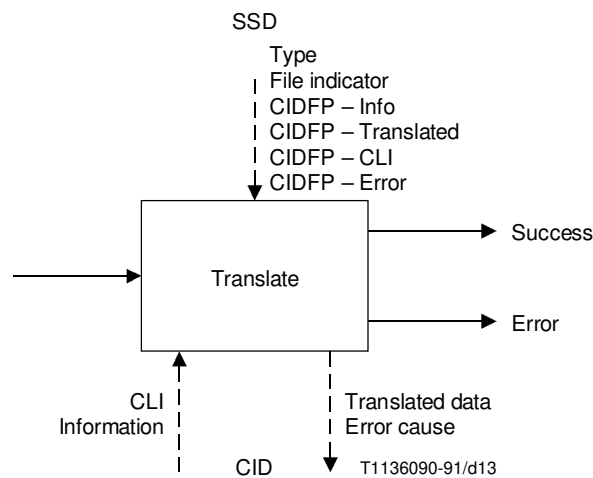

FIGURE 13/Q.1213

Translate SIB

2.12 User interaction

2.12.1 Definition

Allows information to be exchanged between the network and a call party, where a call party can be either a calling or a called party.

2.12.2 Operation

This SIB provides a call party with information (e.g. announcements) and/or collects information from a call party.

The announcements can be, for example:

- DTMF tones;
- a customized or generic audio message;
- network progression tones (e.g. dial tone, busy tone, etc.).

The collected information can be, for example:

- DTMF tones;
- Audio;
- IA5 String text.

This SIB provides the specified announcement (which may be null) to the user. Depending on the repetition type (i.e. count, time), the message is repeated until the repetition number or time is reached.

Expected user input may be null. Assuming it is not null and user interruptibility is allowed, the message is stopped upon initial input by the user. If user interruptibility is not allowed or the message (or message sequence) is completed with no input from the user, the first input should be received within the initial response time after the message (or message sequence) is terminated, otherwise an error condition results.

User input is considered complete when the maximum number of characters has been reached, or an end delineator character is received, or the inter-digit timer has been exceeded.

The stage 2 SDL representation of this SIB may be helpful in understanding its operation. Refer to 5.2.12/Q.1214.

2.12.3 Potential service applications

- Most CS-1 services will require user interaction.

2.12.4 Input

2.12.4.1 Logical start

Indicates the logical start of execution for the SIB.

2.12.4.2 Service support data

- Announcement parameters

Specify the following control values for announcements:

a) Announcement ID

Specifies which announcement is to be sent. The Announcement ID could be “null” to signify that no announcement is to be sent.

b) Repetition requested

Specifies if the announcement is to be repeated.

c) Repetition interval

Specifies the delay period in seconds between repetitions.

- d) Maximum repetitions
Specifies the maximum number of times the announcement will be repeated.
- e) Duration
Specifies the maximum length of time the announcement will be played.
- Collect information parameters
Specify the control values for user entered information.
 - 1) User interruptibility
Specifies if an announcement can be interrupted by the call party entering information (Yes or No).
 - 2) Voice feedback
Specifies if the user is given a vocalization of the users input.
 - 3) Type
Specifies the expected form of the user entered information. The following forms can be identified:
 - i) DTMF;
 - ii) Audio;
 - iii) IA5 String;
 - iv) Null (where Null signifies that no data is to be collected).
 - 4) Maximum number of characters
Specifies the maximum number of characters to collect, ($> = 0$, where 0 identifies non-character input).
 - 5) Minimum number of characters
Specifies the minimum number of characters to collect, ($< =$ the maximum, $> = 0$, where 0 identifies non-character input).
 - 6) Initial input waiting timer
Specifies the maximum time to wait for beginning of call party's response.
 - 7) Inter-character waiting timer
Specifies the maximum time to wait after a pause by the call party.
 - 8) End delineator
Specifies special character(s) signifying the end of an input. If this parameter is "null", no delineator is specified.
- CIDFP-Call_Party
This CID field pointer specifies which call instance data is to be used to identify the call party.
- CIDFP-Collected
This CID field pointer specifies where in output call instance data that the call party entered data is to be written.
- CIDFP-Error
This CID field pointer specifies where in output call instance data the error cause will be written.

2.12.4.3 Call instance data

- Call party identifier
Specifies the data associated with the CIDFP-Call_Party which identifies the call party exchanging information with the network.

2.12.5 Output

2.12.5.1 Logical end

- Success;
- Error.

2.12.5.2 Call instance data

- Collected data

Specifies the data collected by the network from the call party.

- Error cause

Identifies the specific condition which caused an error during the operation of the SIB. The following errors have been identified for User interaction:

- call abandon;
- collection time out (no input received);
- incorrect number of digits received;
- announcement resource unavailable;
- data collection resource unavailable;
- invalid announcement ID;
- invalid call party;
- inconsistent timer setting;
- call status incompatible with playing of announcements;
- call status incompatible with collecting information.

2.12.6 Graphical representation

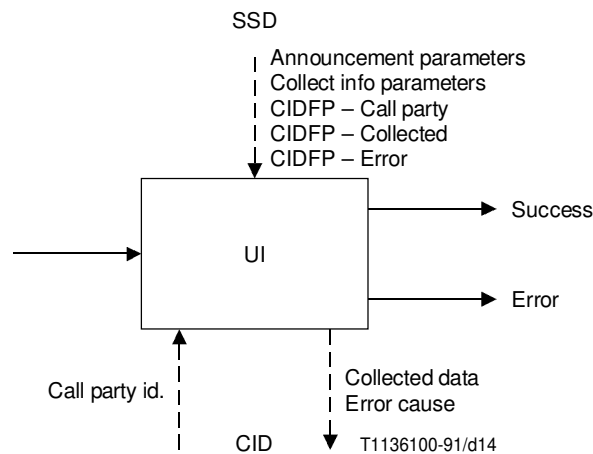

FIGURE 14/Q.1213

User interaction SIB

2.13 Verify

2.13.1 Definition

Provide confirmation that information received is syntactically consistent with the expected form of such information.

2.13.2 Operation

Information is compared with the format expected for the data. The verify SIB normally follows the user interaction SIB when information has been collected from a call party.

The service support data identifies the type of data format. This SIB compares the input data to that expected format.

This SIB may, for example, be used when there is a need to verify the syntax of information. This could be:

- a user identification;
- a network address;
- any extra dialogue such as PIN code dialling or answer to a call prompt.

2.13.3 Potential service applications

- Freephone;
- Selective call forwarding;
- UPT;
- Televoting.

2.13.4 Input

2.13.4.1 Logical start

Indicates the logical start of execution for the SIB.

2.13.4.2 Service support data

- Maximum number of characters
Specifies the maximum number of characters allowed.
- Minimum number of characters
Specifies the minimum number of characters allowed.
- Format
Format specifies the expected syntax of the data being verified. The format is specified using “code” characters. The following “codes” have been identified:
 - 1) x any character;
 - 2) L any letter;
 - 3) A upper case letters only;
 - 4) a lower case letters only;
 - 5) D any digit (0-9) or delineator (#, *);
 - 6) N any digit (0-9);
 - 7) n any digit except 0 (1-9);
 - 8) [x] optional character, where x represents any of the specified “codes”;
 - 9) \x\ specific character(s) required (e.g. \01\ indicated that either a 0 or a 1 must be present at that designated position in the data being verified).

For example, the format “NNNN\x\” would indicate that a PIN code of 2387c would pass syntax verification, while 2387d would fail.
- CIDFP-Data
This CID field pointer specifies which call instance data is to be used as the identifier to be verified.
- CIDFP-Error
This CID field pointer specifies where in output call instance data the error cause will be written.

2.13.4.3 Call instance data

- Identifier
Specifies the data associated with the CIDFP-Data which is to be verified.

2.13.5 Output

2.13.5.1 Logical end

- Pass;
- Fail;
- Error.

2.13.5.2 Call instance data

- Error cause

Identifies the specific condition which caused an error during the operation of the SIB. The following errors have been identified for Verify:

- invalid format;
- invalid identifier;
- inconsistent Max/Min number of characters specified.

2.13.6 Graphical representation

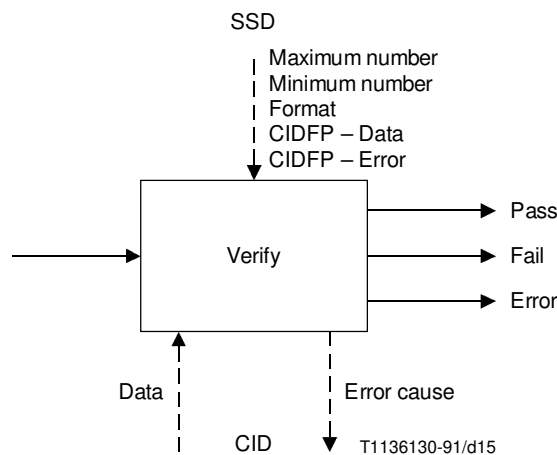

FIGURE 15/Q.1213

Verify SIB

3 Basic call process

3.1 General

The basic call process (BCP) has been defined in 4.0/I.329/Q.1203 as a specialized SIB which provides the basic call capabilities.

These capabilities enable the use of GSL as well as other SIBs to completely describe CS-1 services and service features.

It is not necessary or intended to fully model the BCP on the GFP in CS-1, but rather to insure that the functionality of the BCP that is required on the GFP in conjunction with SIBs be available to fully support CS-1 services/service features.

3.2 Points of initiation and points of return

The BCP functional interfaces to the global service logic in the GFP are described as points of initiation (POI) and points of return (POR). These are defined in 4.2/I.329/Q.1203.

CS-1 service flexibility is provided by defining specific POI and POR interfaces between the BCP and GSL. This flexibility allows a chain of SIBs to represent different services based on the launching POI and the returning POR.

For example, a SIB chain which screens a network address against a list could represent an originating call screening service if the *Address Analysed* POI launches the chain. However, if the *Prepared to Complete Call* POI was used to launch the same chain, a terminating call screening service could result.

Furthermore, using the screening example from above, different services can result based upon which POR is used to complete the chain. If a "Match" logic end of the SCREEN SIB, is followed by a *Proceed with New Data* POR, a call is allowed to complete and this is an example of positive screening. However, negative screening, or call blocking, can be done with the same SIB chain by having the "Match" followed by a *Clear Call* POR.

3.2.1 List of POIs

The following set of POIs has been identified for CS-1.

Call originated

This POI identifies that the user has made a service request without yet specifying a destination address (e.g. off-hook but before dialling).

Address collected

This POI identifies that the address input has been received from the user.

Address analysed

This POI identifies that the address input has been analysed to determine characteristics of the address (e.g. freephone number).

Prepared to complete call

This POI identifies that the network is prepared to attempt completion of the call to the terminating party.

Busy

This POI identifies that the call is destined for a user who is currently busy.

No answer

This POI identifies that the call has been offered to a user who has not answered.

Call acceptance

This POI identifies that the call is active but the connection between the calling and called parties is not established (e.g. called party off-hook but no switch-through).

Active state

This POI identifies that the call is active and the connection between the calling and called parties is established.

End of call

This POI identifies that a call party has disconnected.

3.2.2 List of PORs

The following set of PORs has been identified for CS-1.

Continue with existing data

This POR identifies that the BCP should continue call processing with no modification.

Proceed with new data

This POR identifies that the BCP should proceed with call processing with only a data modification.

Handle as transit

This POR identifies that the BCP should treat the call as if it had just arrived.

Clear call

This POR identifies that the BCP should clear the call.

Enable call party handling

This POR identifies that the BCP should perform functions to enable call control for individual call parties.

The use of this POR and the definition of any additional SIBs needed to support call party handling are for further study.

Initiate call

This POR identifies that the call should be initiated. This may be independent of an existing call, or may be in the context of an existing call.

3.3 BCP stage 1 description

3.3.1 Definition

This specialized SIB allows access to IN services/service features represented through the use of chains of SIBs and global service logic. The interface points between this SIB and GSL are described as POIs and PORs.

3.3.2 Operation

The BCP contains a set of armed POIs, and if during the processing of a call, one of these POIs is encountered, a chain of SIB is executed through global service logic.

When the chain of SIB terminates, call processing may be influenced according to the specified POR.

Note that non-IN supported services are processed in the BCP and no GSL processing is required.

3.3.3 Potential service applications

- All CS-1 services.

3.3.4 Output

Specifies the POI and data parameters which are passed to GSL.

3.3.4.1 Logical output

Initiate global service logic from a specified POI.

3.3.4.2 Service support data

- Set of POIs
Specifies the points in the BCP where IN service logic processing can occur for a given service.
- CIDFP-CLI
This CID field pointer specifies which call instance data is to be used as the CLI.
- CIDFP-Category
This CID field pointer specifies which call instance data is to be used as the CLI category data.
- CIDFP-Dialled
This CID field pointer specifies which call instance data is to be used as the dialled number.
- CIDFP-Destination
This CID field pointer specifies which call instance data is to be used as the destination number.
- CIDFP-Call Reference
This CID field pointer specifies which call instance data identifies the call reference.
- CIDFP-Bearer
This CID field pointer specifies which call instance data is to be used as the CLI bearer capability.

3.3.4.3 Call instance data

- Calling line identity
Specifies the network address from which the call in progress originated.
- Calling line category
Specifies the characteristics of CLI (e.g. payphone, operator, etc.).
- Dialled number
Specifies the number(s) dialled by the caller.
- Destination number
Specifies the number(s) dialled by the caller (the destination number although originally the same as the dialled number, may be modified through IN service processing).
- Call reference
Identifies a specific call.
- Bearer capabilities
Specifies the ISDN bearer capabilities (see Recommendation Q.931) requested by the caller.

3.3.5 Input

3.3.5.1 Logical input

Resume BCP at the point specified by the GSL specified POR.

3.3.5.2 Call instance data

- Destination number
Specifies a network address to which the call in progress is to be connected. For instance, a chain of SIBs may be used to create a destination number which differs from the dialled number.

3.3.6 Graphical representation

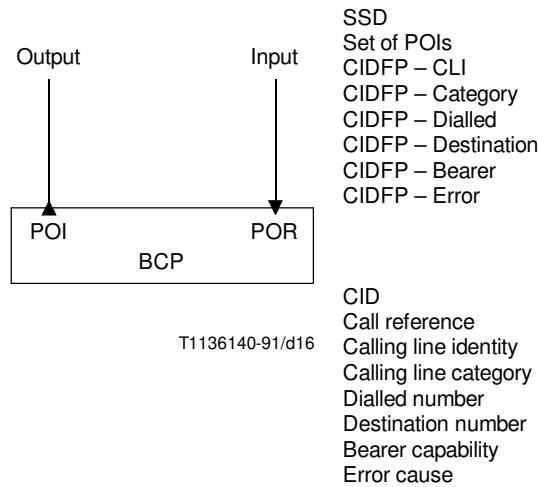

FIGURE 16/Q.1213
Basic call process SIB

4 Global service logic

Global service logic (GSL) has been defined in 5/I.329/Q.1203 as the “glue” that describes the order in which SIBs can be chained together to accomplish services.

For a given CS-1 services/service feature, global service logic is used to describe:

- i) A specific POI which will define the functional launching point from the BCP to the SIB chain. Refer to 3.2.1 for a list of CS-1 POIs.
- ii) A specific set of PORs where the SIB chain can logically return to the BCP. Refer to 3.2.2 for a list of CS-1 POIs.
- iii) The pattern and order of SIBs which are to be chained together. This pattern begins at the POI defined in i) and ends at the set of PORs defined by ii). Refer to 2 for a list of CS-1 SIBs.
- iv) Data parameters (SSD and CID) for each SIB in the SIB chain.

5 Mapping of the service plane to the global functional plane

No unique CS-1 service plane to global functional plane mapping relationships have been identified over and above what has been defined in I.329/Q.1203.