



INTERNATIONAL TELECOMMUNICATION UNION

ITU-T

TELECOMMUNICATION
STANDARDIZATION SECTOR
OF ITU

Q.1152

(03/93)

**INTERWORKING WITH
SATELLITE MOBILE SYSTEMS**

**PROCEDURES FOR INTERWORKING
BETWEEN INMARSAT AERONAUTICAL
MOBILE SATELLITE SYSTEM AND THE
INTERNATIONAL PUBLIC SWITCHED
TELEPHONE NETWORK/ISDN**

ITU-T Recommendation Q.1152

(Previously "CCITT Recommendation")

FOREWORD

The ITU Telecommunication Standardization Sector (ITU-T) is a permanent organ of the International Telecommunication Union. The ITU-T is responsible for studying technical, operating and tariff questions and issuing Recommendations on them with a view to standardizing telecommunications on a worldwide basis.

The World Telecommunication Standardization Conference (WTSC), which meets every four years, established the topics for study by the ITU-T Study Groups which, in their turn, produce Recommendations on these topics.

ITU-T Recommendation Q.1152 was revised by the ITU-T Study Group XI (1988-1993) and was approved by the WTSC (Helsinki, March 1-12, 1993).

NOTES

1 As a consequence of a reform process within the International Telecommunication Union (ITU), the CCITT ceased to exist as of 28 February 1993. In its place, the ITU Telecommunication Standardization Sector (ITU-T) was created as of 1 March 1993. Similarly, in this reform process, the CCIR and the IFRB have been replaced by the Radiocommunication Sector.

In order not to delay publication of this Recommendation, no change has been made in the text to references containing the acronyms "CCITT, CCIR or IFRB" or their associated entities such as Plenary Assembly, Secretariat, etc. Future editions of this Recommendation will contain the proper terminology related to the new ITU structure.

2 In this Recommendation, the expression "Administration" is used for conciseness to indicate both a telecommunication administration and a recognized operating agency.

© ITU 1994

All rights reserved. No part of this publication may be reproduced or utilized in any form or by any means, electronic or mechanical, including photocopying and microfilm, without permission in writing from the ITU.

CONTENTS

	<i>Page</i>
1 Introduction	1
2 Conversion of information elements	1
2.1 Signalling System R2	1
2.2 Signalling System No. 7 (TUP)	4
2.3 Signalling System No. 5	6
3 Incoming INMARSAT aeronautical logic procedures (air-to-ground calls)	6
4 Outgoing INMARSAT aeronautical logic procedures (ground-to-air calls)	16
5 Interworking of INMARSAT aeronautical signalling system with itself	21
6 Interworking of incoming INMARSAT aeronautical to Signalling System R2	23
7 Interworking of Signalling System R2 to outgoing INMARSAT aeronautical	26
8 Interworking of incoming INMARSAT aeronautical to Signalling System No. 7 (TUP)	29
9 Interworking of Signalling System No. 7 (TUP) to outgoing INMARSAT aeronautical	29
10 Interworking of incoming INMARSAT aeronautical to Signalling System No. 5	35
11 Interworking of Signalling System No. 5 to outgoing INMARSAT aeronautical	35

**PROCEDURES FOR INTERWORKING BETWEEN INMARSAT AERONAUTICAL
MOBILE SATELLITE SYSTEM AND THE INTERNATIONAL
PUBLIC SWITCHED TELEPHONE NETWORK/ISDN**

(Melbourne, 1988; modified at Helsinki, 1993)

1 Introduction

This Recommendation provides the detailed procedures for interworking between the INMARSAT aeronautical system and signalling systems of the public fixed network. For a brief description of the INMARSAT aeronautical system, see Appendix I/Q.1151.

2 Conversion of information elements

Tables 1 and 2 list the signals of the INMARSAT aeronautical system that are relevant for the purpose of interworking with the PSTN/ISDN. The forward interworking telephone events (FITEs) and backward interworking telephone events (BITEs), as defined in Annex A/Q.601-Q.608, that correspond to each of these signals is also provided in the tables.

TABLE 1/Q.1152

INMARSAT aeronautical – forward signals

FITE No.	Message: information element: value
Ground-to-air calls	
1	Call announcement: AES id: called terminal
17	Call announcement: service: telephone
22	Channel release: Cause: Normal clearing
Air-to-ground calls	
17	Access request: message type: public/crew voice
18	Access request: message type: crew distress voice
1	Access request: address digits 0, 1
1	Call information: address digits 2 ... 17
22	Channel release: Cause: Normal clearing
NOTE – Signals required for interworking with Signalling System No. 7 (ISUP) are for further study.	

Tables 3 to 18 give the relationship between signals of the fixed network signalling systems and the INMARSAT aeronautical system.

2.1 Signalling System R2

2.1.1 Table 3 gives the relationship between messages in the INMARSAT aeronautical signalling system and forward signals in Signalling System R2 for air-to-ground calls, i.e. interworking of INMARSAT aeronautical to Signalling System R2.

Table 4 shows the relationship between forward signals in Signalling System R2 and messages in the INMARSAT aeronautical signalling system for ground-to-air calls. In the comment column actions taken by the MSSC are indicated,

in particular for signals of R2 which have no equivalent message in the INMARSAT aeronautical system.

The signal numbers for forward signals of Signalling System R2 are those given in Table A.7/Q.601-Q.608.

TABLE 2/Q.1152

INMARSAT aeronautical – backward signals

BITE No.	Message: information element: value
Ground-to-air-calls	
5	Test
22	Connect
29	Channel release: Cause: Normal clearing
16	Call attempt result: Cause: User busy
12	Call attempt result: Cause: No channel available
17	Call attempt result: Cause: Destination out of service
Air-to-ground-calls	
22	Connect
2	Call attempt result: Address complete
29	Channel release: Cause: Normal clearing
20	Channel release: Cause: Unspecified
16	Channel release: Cause: User busy
15	Channel release: Cause: Unassigned number
17	Channel release: Cause: Destination out of service
12	Channel release: Cause: No channel available
14	Channel release: Cause: Invalid number format
NOTE – Signals required for interworking with Signalling System No. 7 (ISUP) are for further study.	

TABLE 3/Q.1152

**Conversion of forward signals in the INMARSAT aeronautical signalling system to Signalling System R2
Air-to-ground calls**

INMARSAT aeronautical signalling system Message: information element: value	Signalling System R2 Signal name: information element	Signal No.
Access request: message type	Calling party's category	
– public voice	– subscriber/operator without forward transfer facility	12
– crew voice	– subscriber/operator without forward transfer facility	12
– crew distress voice	– subscriber/with priority	14
Access request: address digits 0, 1	Country code indicator (echo suppressor controls)	10
Call information: digits 2 to 17	Address signals/first digit	1
Test	Not applicable	
Channel release: Cause: Normal clearing	Clear forward	16
NOTE – Signal No. 21, nature of circuit indicator: one satellite circuit in the connection, is generated by the MSSC, if required.		

TABLE 4/Q.1152

**Conversion of forward signals in Signalling System R2
to INMARSAT aeronautical signalling system
Ground-to-air calls**

Signal No.	Signalling System R2 Signal name	INMARSAT aeronautical signalling system Message: information element: value	Comments
1	Address signals	Call announcement: AES identity, called terminal	
2-6	Language digit: I-1, ... 5		Interpreted by MSSC
7	Discriminating digit		Interpreted by MSSC
8	Country code indicator, outgoing half suppressor required		MSSC will insert echo control device if needed
9	Country code indicator, no echo suppressor required		Interpreted by MSSC
10, 11	Country code indicator, incoming half echo suppressor required		Interpreted by MSSC
12	Calling party's category, subscriber or operator without forward transfer facility	Call announcement – service: telephone	
13	Calling party's category, data transmission control		Not applicable
14	Calling party's category, subscriber with priority	Call announcement – service: telephone, priority for further study	
15	Calling party's category, operator with forward transfer capability	Call announcement – service: telephone	
16	Clear forward	Channel release: Cause: Normal clearing	
17	Forward transfer		Not applicable
18	First digit: I-1, I-2 ... I-10		Interpreted by MSSC
19	Reply to A-14: I-1 ... I-10		Not applicable
20	Reply to first A-13; I-13		Not applicable
21	Reply to first A-13; I-14		Not applicable

2.1.2 Table 5 gives the relationship between messages in the INMARSAT aeronautical signalling system and backward signals in Signalling System R2 for ground-to-air calls, i.e. interworking of Signalling System R2 to INMARSAT aeronautical.

Backward signals in Signalling System R2 generated by the MSSC for unsuccessful ground-to-air calls are given in Table 5 bis. These signals are not related to any specific message received from the aircraft earth station.

TABLE 5/Q.1152

**Conversion of backward signals in the INMARSAT aeronautical
signalling system to Signalling System R2
Ground-to-air-calls**

INMARSAT aeronautical signalling system Message: information element: value	Signalling System R2 Signal name: information element	Signal No.
Test	International, subscriber line free, charge	13
Connect	Answer signal	11
Channel release: Cause: Normal clearing	Clear back	12
Call attempt result: Cause:		
– user busy	Subscriber line busy	5
– no channel available	Congestion on the national network	1
– destination out of service	Subscriber line out of order	10
– others	International; send special info tone	14

TABLE 5 bis/Q.1152

**Unsuccessful call events and backward signals in Signalling System R2
Ground-to-air-calls**

INMARSAT aeronautical signalling system Event in INMARSAT system	Signalling System R2 Signal name: information element	Signal No.
Congestion in MSSC	B4 – Congestion	6
Incomplete AES number	B5 – Unallocated number	7
Continuity test failure	B8 – Subscriber line out of order	10
AES barred for incoming access	B2 – Send special info tone	4
Called AES not logged on	B2 – Send special info tone	4
No satellite channel frequency/equipment available	B4 – Congestion	6

Table 6 gives the relationship between backward signals in Signalling System R2 and messages in the INMARSAT aeronautical signalling system for air-to-ground calls, i.e. interworking of INMARSAT aeronautical to Signalling System R2. The comments column indicates specific actions taken by the MSSC.

The signal number of backward signals of Signalling System R2 are those given in Table A.11/Q.601-Q.608.

2.2 Signalling System No. 7 (TUP)

2.2.1 Tables 7 and 8 are similar to Tables 3 and 4, respectively, and apply to forward signals in Signalling System No. 7 (TUP).

The signal numbers for forward signals of Signalling System No. 7 (TUP) are those given in Table A.5 bis/Q.601-Q.608.

TABLE 6/Q.1152

**Conversion of backward signals in Signalling System R2
to INMARSAT aeronautical signalling system
Air-to-ground calls**

Signal No.	Signalling System R2 Signal name	INMARSAT aeronautical signalling system Message: information element: value	Comments
1	A4 – Congestion on the national network	Channel release: remote public network, switching equipment congestion	
2	A6 – Address complete, charge, set up, speech condition	Call attempt result: address complete	
3	A15 – Congestion in an international exchange or at its output	Channel release: international network, switching equipment congestion	
4	B2 – Send special information tone	Channel release: remote public network, normal – unspecified	
5	B3 – Subscriber line busy	Channel release: remote public network, user busy	
6	B4 – Congestion	Channel release: remote public network, switching equipment congestion	
7	B5 – Unallocated number	Channel release: remote public network, unassigned number	
8	B6 – Subscriber line free, charge	Call attempt result: address complete	
9	B7 – Subscriber line free, no charge	Call attempt result: address complete	No-charge information, used by MSSC only
10	B8 – Subscriber line out of order	Channel release: remote public network, destination out of service	
11	Answer	Connect	
12	Clear back	Channel release: Cause: Normal clearing	Clearback supervision done by MSSC
13	B1-B6 – International, subscriber line free, charge	Call attempt result: address complete	
14	B9, B10 – International, send special information tone	Channel release: international network, normal – unspecified	
15	B11-B15 – Congestion	Channel release: remote public network, switching equipment congestion	

2.2.2 Tables 9, 9 *bis* and 10 are similar to Tables 5, 5 *bis* and 6, respectively, and apply to backward signals in Signalling System No. 7 (TUP).

The signal numbers for backward signals in Signalling System No. 7 (TUP) are those given in Table A.9 *bis*/Q.601-Q.608.

TABLE 7/Q.1152

**Conversion of forward signals in INMARSAT aeronautical signalling system
to Signalling System No. 7
Air-to-ground calls**

INMARSAT aeronautical signalling system Message: information element: value	Signalling System No. 7 Signal name: information element	Signal No.
Access request: message type	Calling party's category indicator:	13
Public voice/	Ordinary subscriber/	13
Crew voice/	Ordinary subscriber/	13
Crew distress voice/	Subscriber with priority	14
Access request: address digits 0, 1	Address signals: Digit 1, 2 ... 0	1
Call information: digit 2 to 17	nature of address indicator, international number	3
Test	Continuity check performed on previous circuit	22
Channel release: Cause: Normal clearing	Clear forward signal	16
NOTE – Signal No. 5, nature of circuit indicator, one satellite in connection, is generated by the MSSC.		

2.3 Signalling System No. 5

2.3.1 Tables 11 and 12 are similar to Tables 3 and 4, respectively, and apply to forward signals in Signalling System No. 5.

The signal numbers for forward signals of Signalling System No. 5 are those given in Table A.4/Q.601-Q.608.

2.3.2 Tables 13, 13 *bis* and 14 are similar to Tables 5, 5 *bis* and 6, respectively, and apply to backward signals in Signalling System No. 5.

The signal numbers for backward signals in Signalling System No. 5 are those given in Table A.8/Q.601-Q.608.

2.4 The relationship between forward and backward signals of Signalling System No. 7 (ISUP) and messages of the INMARSAT aeronautical signalling system is for further study.

3 Incoming INMARSAT aeronautical logic procedures (air-to-ground calls)

Figure 1 contains the procedures for the incoming INMARSAT aeronautical signalling system.

This description only includes those aspects of the INMARSAT aeronautical system which have to be implemented for interworking purposes. Internal procedures, such as those required for setting up and clearing satellite channels are not shown. This also applies to pre-emption procedures for assigning channels to distress calls.

The following details should be noted:

3.1 The access request contains information elements for the required service, and the required network, plus two address digits. For some private networks, and/or subscription services on public networks, this information will be sufficient to determine the complete call routing. In all but the most exceptional cases, it will be enough information to select a circuit for onward routing from the MSSC.

TABLE 8/Q.1152

**Conversion of forward signals in Signalling System No. 7 TUP
to INMARSAT aeronautical signalling system
Ground-to-air calls**

Signal No.	Signalling System No. 7 Signal name	INMARSAT aeronautical signalling system Message: information element: value	Comments
1	Address signals	Call announcement: AES ID, called terminal	
2	Nature of address indicator, national significant number	–	Interpreted by MSSC
3	Nature of address indicator, international number	–	Interpreted by MSSC
4	Nature of circuit indicator, no satellite in connection	–	Ignored by MSSC
5	Nature of circuit indicator, one satellite in connection	–	Ignored by MSSC
6	Echo suppressor indicator, outgoing half-echo suppressor not included	–	MSSC will insert echo control device if needed
7	Echo suppressor indicator, outgoing half-echo suppressor included	–	Interpreted by MSSC
8-12	Calling party's category indicator, language digit	Call announcement – service: telephone	–
13	Calling party's category indicator, ordinary calling subscriber	Call announcement – service: telephone	–
14	Calling party's category indicator, calling subscriber with priority	Call announcement – service: telephone, priority for further study	–
15	Calling party's category indicator, data call	–	Not applicable
16	Clear forward	Channel release: Cause: Normal clearing	–
17	Forward transfer	–	Not applicable
18	Continuity proved	–	Interpreted by MSSC
19	Continuity check failure	Channel release: Cause: Normal clearing	–
20	Continuity check not required on this circuit	–	Interpreted by MSSC
21	Continuity check not required on this circuit	–	Interpreted by MSSC
22	Continuity check performed on previous circuit	–	Interpreted by MSSC
23	Service information	–	Interpreted by MSSC
24	General set-up message	–	Interpreted by MSSC

3.2 The initial analysis of the request checks that the AES is authorized for the service requested and finds a suitable channel and channel unit, on which to service the call. The call is aborted if the AES is not an authorized user of the INMARSAT system.

3.3 In the cases where all of the required address information is contained in the access request signal unit, an address message is received by the incoming procedure, once continuity of the assigned satellite channel has been successfully tested.

TABLE 9/Q.1152

**Conversion of backward signals in INMARSAT aeronautical signalling system
to Signalling System No. 7 TUP
Ground-to-air calls**

INMARSAT aeronautical signalling system Message: information element: value	Signalling System No. 7 Signal name	Signal No.
Test	AFC: Address complete, subscriber free, charge	4
Connect	ANC: Answer, charge	16
Channel release: Cause: Normal clearing	CLB: Clear back	19
Call attempt result: Cause:		
– user busy	SGB: Subscriber busy	12
– no channel available	CGC: Circuit group congestion	8
– destination out of service	LOS: Line out of service	13
– others	SST: Send special information tone	14

TABLE 9 bis/Q.1152

**Unsuccessful events and backward signals in Signalling System No. 7
Ground-to-air calls**

INMARSAT aeronautical signalling system Event in INMARSAT system	Signalling System No. 7 Signal name	Signal No.
Congestion in MSSC	SEC: Switching equipment congestion	7
No satellite channel frequency/equipment available	NNC: National network congestion	9
Incomplete AES number	ADI: Address incomplete	10
Continuity test failure	LOS: Line out of service	13
AES barred for incoming access	SST: Send special information tone	14
Call AES not logged on	SST: Send special information tone	14

3.4 The called address is analysed to verify its integrity. The satellite channel may be cleared at this point, either if the dialled address is incomplete or if the AES goes on-hook. The call may also be aborted if proper credit card data is not received from the AES.

3.5 The dialled digits are transferred to the interworking procedure, and the answer signal is awaited. The last digit may be withheld until receipt of credit card information. All successful address complete signals are converted to a call attempt result message, with the cause field set to address complete.

3.6 Unsuccessful call event signals (BITEs 9-20) are transferred to the AES by the call attempt result message, with the cause field set appropriately.

3.7 On receipt of the answer signals, the connect message is sent to the AES.

3.8 The call is cleared in the normal way, either on receipt of a release message from the interworking procedure, or an indication of AES on-hook conveyed by means of a channel release message.

TABLE 10/Q.1152

**Conversion of backward signals in Signalling System No. 7 TUP
to INMARSAT aeronautical signalling system
Air-to-ground calls**

Signal No.	Signalling System No. 7 Signal name	INMARSAT aeronautical signalling system Message: information element: value	Comments
1	ADC: Address complete, charge	Call attempt result: Address complete	–
2	ADN: Address complete, no charge	Call result: Address complete	No-charge information used by MSSC only
3	ADX: Address complete, coinbox	Call result: Address complete	–
4	AFC: Address complete, subscriber free, charge	Call result: Address complete	–
5	AFN: Address complete, subscriber free, no charge	Call result: Address complete	No-charge information used by MSSC only
6	AFX: Address complete, subscriber free, coinbox	Call result: Address complete	–
7	SEC: Switching equipment congestion	Channel release: international network, switching equipment congestion	–
8	CGC: Circuit-group congestion	Call result: international network, no channel available	–
9	NNC: National network congestion	Call result: remote public network, switching equipment congestion	–
10	ADI: Address complete	Call result: remote public network, invalid number format	–
11	UNN: Unallocated number	Call result: remote public network, unassigned number	–
12	SGB: Subscriber busy	Call result: remote public network, user busy	–
13	LOS: Line out of service	Call result: remote public network, destination out of service	–
14	SST: Send special information tone	Call result: international network, normal – unspecified	–
15	CFL: Call failure	Call result: international network, normal – unspecified	–
16	ANC: Answer, charge	Connect	–
17	ANN: Answer, no charge	Connect	No charge information used by MSSC only
18	RAN: Reanswer	Connect	–
19	CLB: Clearback	Channel release: Cause: Normal clearing	Clearback supervision done by MSSC
20	GRQ: General request message	–	Interpreted by MSSC
21	Call unsuccessful, access barred	Call attempt result: remote public network, normal – unspecified	–
22	DPN: Call unsuccessful, digital path not provided	–	Not applicable

TABLE 11/Q.1152

**Conversion of forward signals in INMARSAT aeronautical signalling system
to Signalling System No. 5
Air-to-ground calls**

INMARSAT aeronautical signalling system Message: information element: value	Signalling System No. 5 Signal name	Signal No.
Access request: message type		
– public voice	Discriminating digit 0	7
– crew voice	Discriminating digit 0	7
– crew distress voice	Discriminating digit 0	7
Access request: address digits: 0, 1	Address digits	1
Call information: digits 2 to 17		
Test	Not applicable	–
Channel release: Cause: Normal clearing	Clear forward	10

TABLE 12/Q.1152

**Conversion of forward signals in INMARSAT aeronautical signalling system
to Signalling System No. 5
Ground-to-air calls**

Signal No.	Signalling System No. 5 Signal name	INMARSAT aeronautical signalling system Message: information element: value	Comments
1	Address signals	Call announcement: AES identity, called terminal	
2-6	Language digit: 1 ... 5	–	Interpreted by MSSC
7	Discriminating digit 0	Call announcement – service: telephone	
8	Start of pulsing signal KP1	–	Interpreted by MSSC
9	Start of pulsing signal KP2	–	Interpreted by MSSC
10	Clear forward	Channel release: Cause: Normal clearing	
11	Forward transfer	–	Not applicable

TABLE 13/Q.1152

**Conversion of backward signals in INMARSAT aeronautical signalling system
to Signalling System No. 5
Ground-to-air calls**

INMARSAT aeronautical signalling system Message: information element: value	Signalling System No. 5 Signal name	Signal No.
Test	Inform that ST has been sent	5
Connect	Answer signal	2
Channel release: Cause: Normal clearing	Clear back	3
Call attempt result: Cause:		
– user busy	Busy flash signal	1
– no channel available	Busy flash signal	1
– destination out of service	Information tone (Note)	–
– others	Information tone (Note)	–
NOTE – May include appropriate recorded announcement.		

TABLE 13 bis/Q.1152

**Unsuccessful call events and backward signals in Signalling System No. 5
Ground-to-air calls**

INMARSAT aeronautical signalling system Event in INMARSAT system	Signalling System No. 5 Signal name	Signal No.
Congestion in MSSC	Busy flash	1
No satellite channel frequency/equipment available	Busy flash	1
Incomplete AES number	Information tone (Note)	
Continuity test failure	Information tone (Note)	
Called AES not logged on	Information tone (Note)	
AES barred for incoming access	Information tone (Note)	
NOTE – May include appropriate recorded announcement.		

TABLE 14/Q.1152

**Conversion of backward signals in Signalling System No. 7
to INMARSAT aeronautical signalling system
Air-to-ground calls**

Signal No.	Signalling System No. 5 Signal name	INMARSAT aeronautical signalling system Message: information element: value	Comments
1	Busy-flash	Channel release: international network, unspecified	–
2	Answer	Connect	–
3	Clear back	Channel release: Cause: Normal clearing	–
4	Proceed to send	–	Interpreted by MSSC
5	Inform that ST has been sent	Call attempt result: address complete	

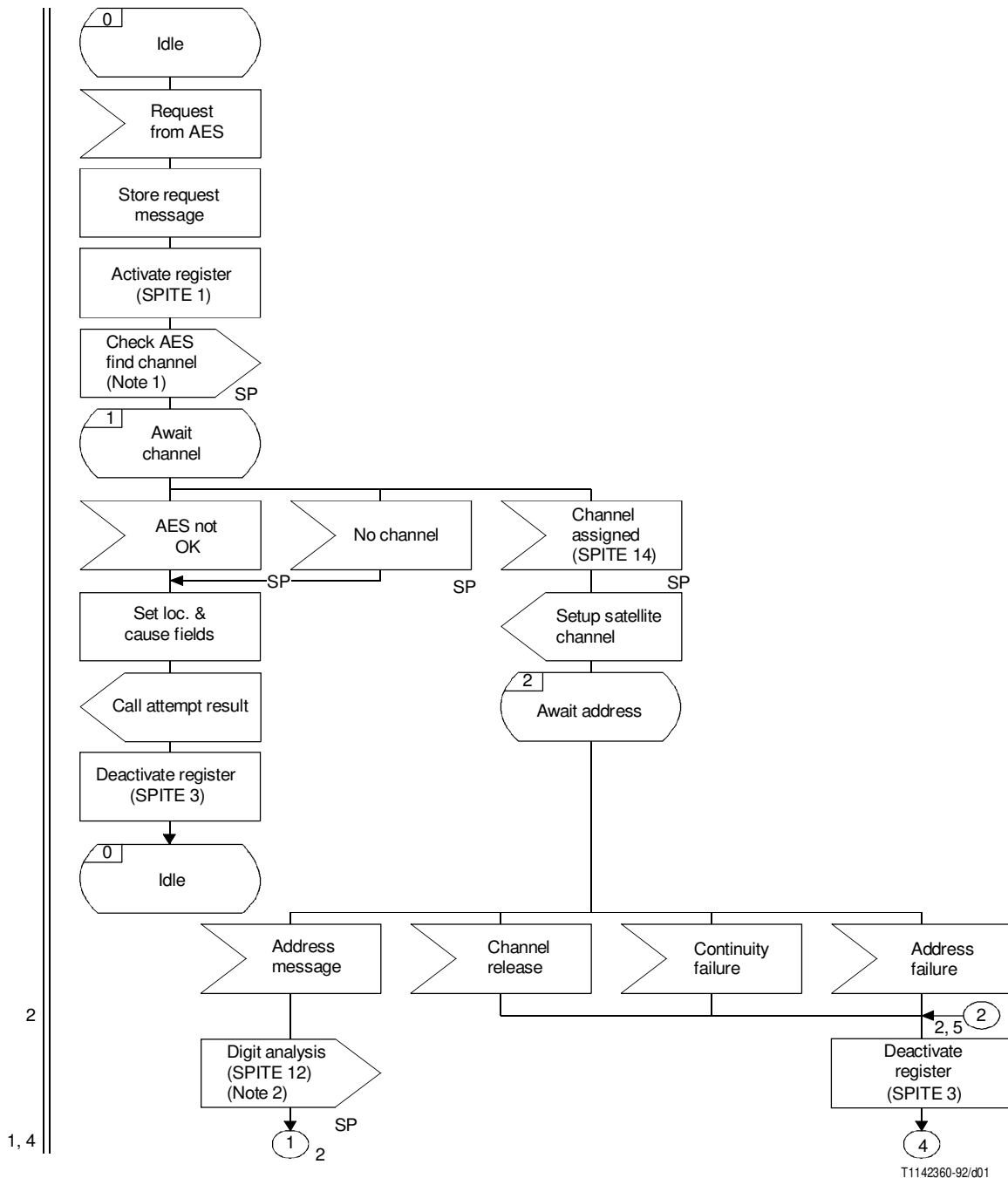

NOTES

- 1 Analyse for authorized AES ID, availability of service requested, find a suitable satellite channel and channel unit.
- 2 Includes translation of prefixes to the appropriate B-party number, and verification that the number is valid.

FIGURE 1/Q.1152 (sheet 1 of 7)
**Logic procedures for incoming INMARSAT aeronautical signalling
 (air-to-ground calls)**

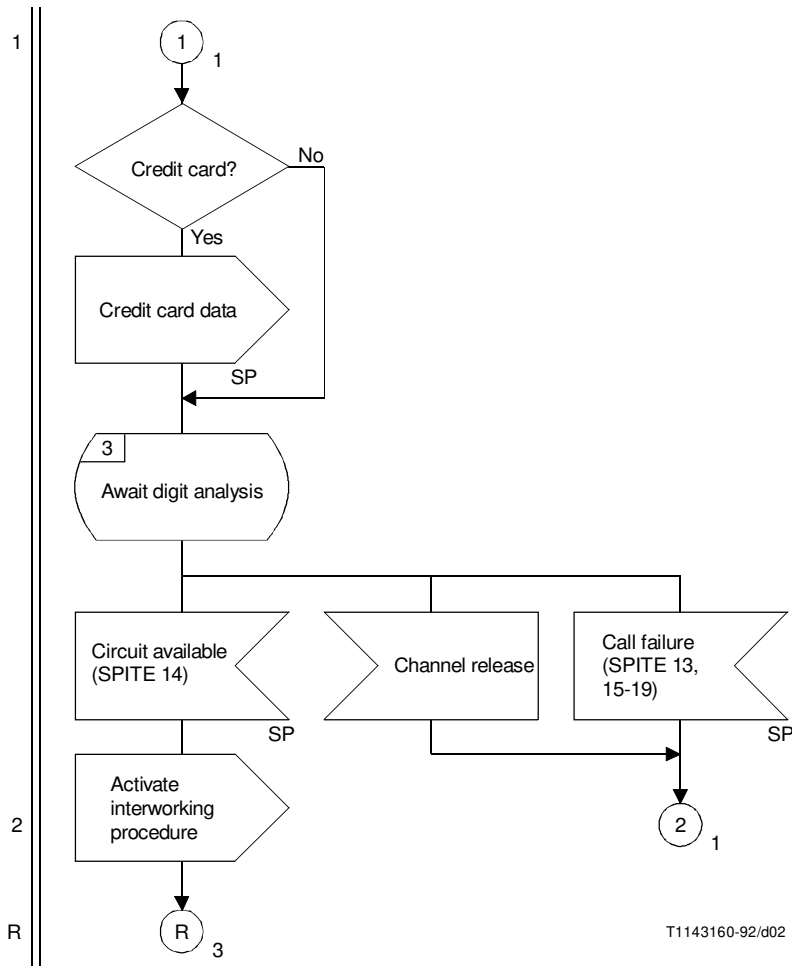

T1143160-92/d02

FIGURE 1/Q.1152 (sheet 2 of 7)
 Logic procedures for incoming INMARSAT aeronautical signalling
 (air-to-ground calls)

R
4

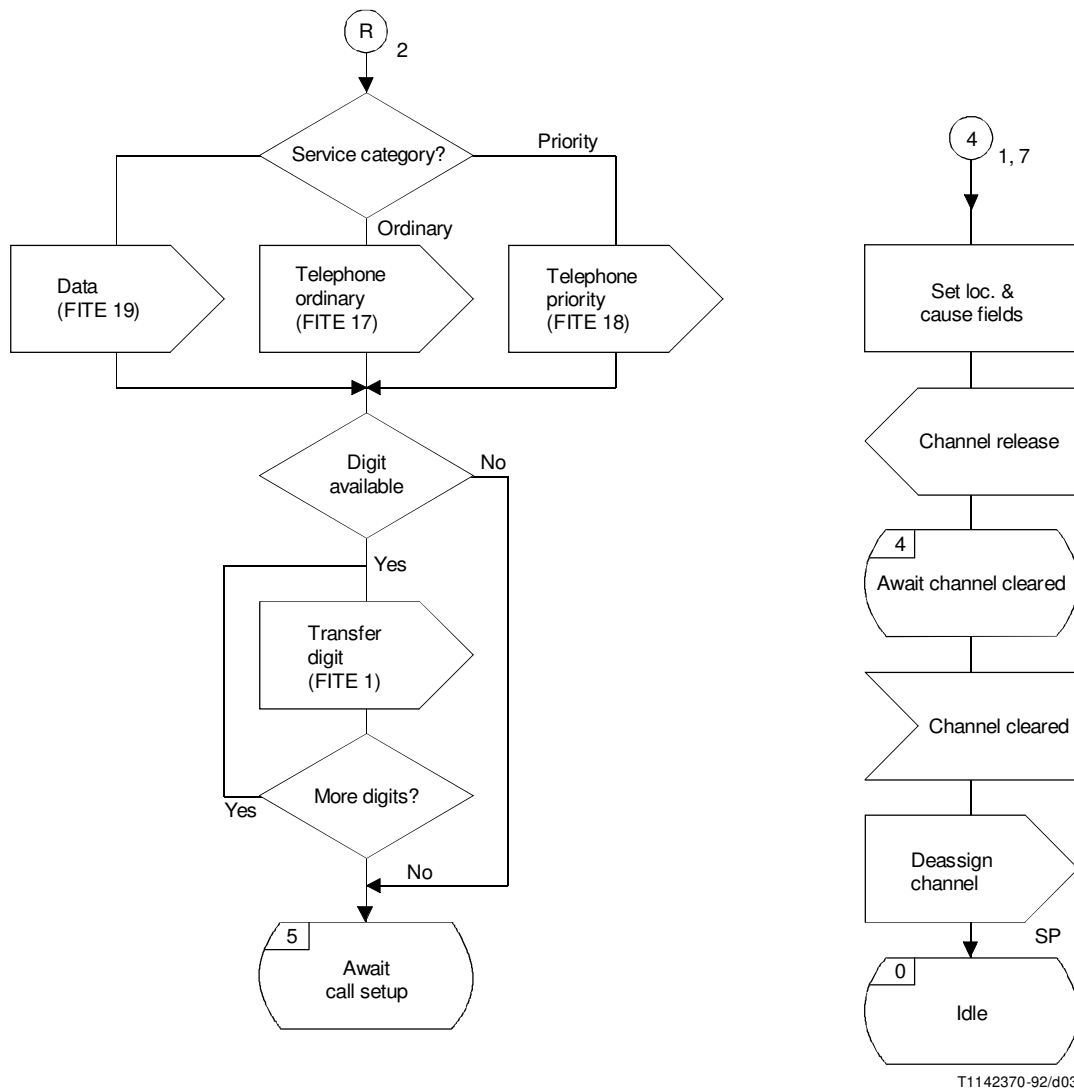

FIGURE 1/Q.1152 (sheet 3 of 7)
Logic procedures for incoming INMARSAT aeronautical signalling
(air-to-ground calls)

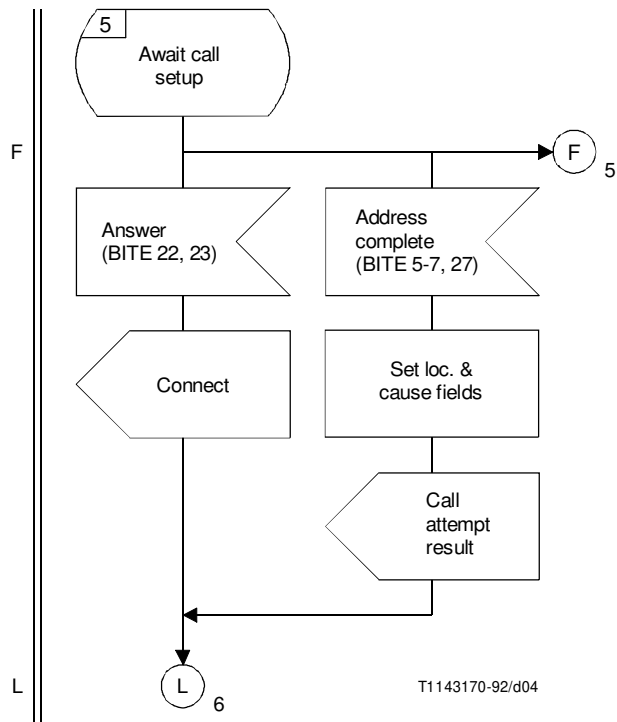

FIGURE 1/Q.1152 (sheet 4 of 7)
Logic procedures for incoming INMARSAT aeronautical signalling (air-to-ground calls)

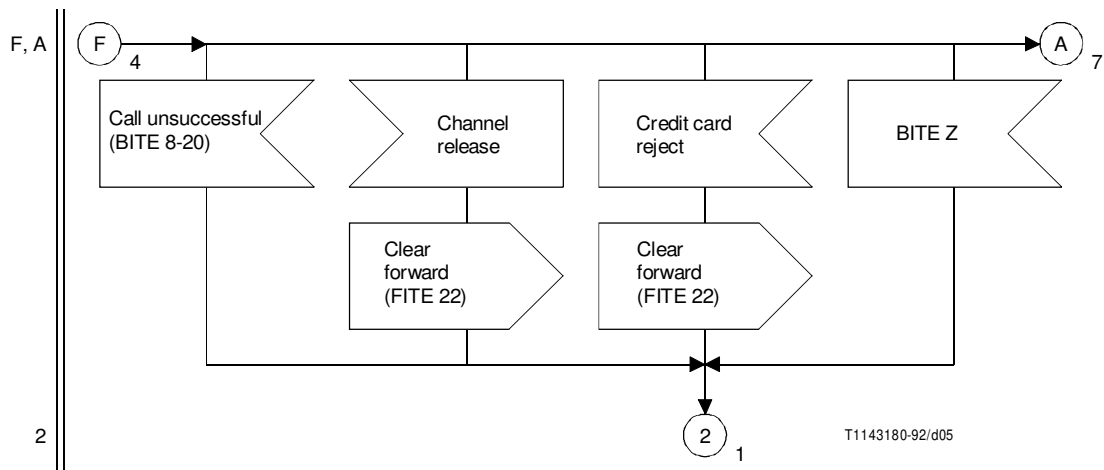

FIGURE 1/Q.1152 (sheet 5 of 7)
Logic procedures for incoming INMARSAT aeronautical signalling (air-to-ground calls)

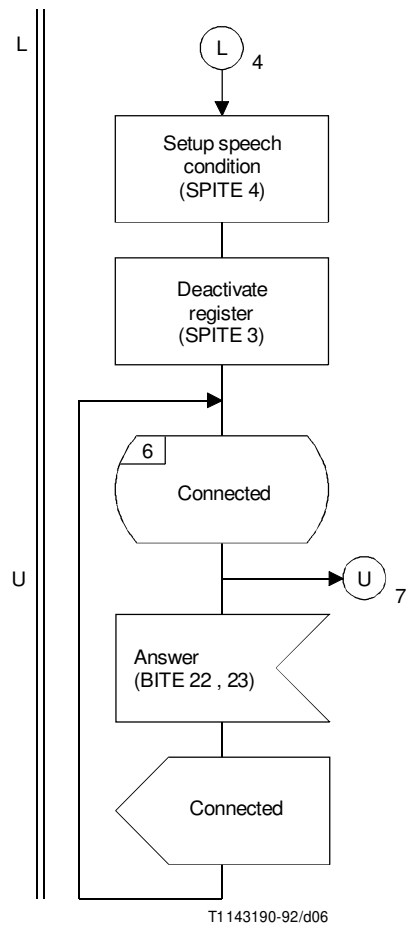

FIGURE 1/Q.1152 (sheet 6 of 7)
**Logic procedures for incoming INMARSAT aeronautical
 signalling (air-to-ground calls)**

4 Outgoing INMARSAT aeronautical logic procedures (ground-to-air calls)

Figure 2 contains the procedures for the outgoing INMARSAT aeronautical signalling system.

This description only includes the aspects of the INMARSAT aeronautical system which have to be implemented for interworking purposes. Internal procedures, such as those required for setting up and clearing satellite channels are not shown. This also applies to pre-emption procedures for assigning channels to distress calls.

The following details should be noted:

4.1 The outgoing INMARSAT procedure receives the calling party indicator, and address digits from the interworking process. It determines whether the addressed AES is an authorized user and if it is logged on in the same satellite region. BITE 15 is returned to the terrestrial network if the dialled AES number is invalid.

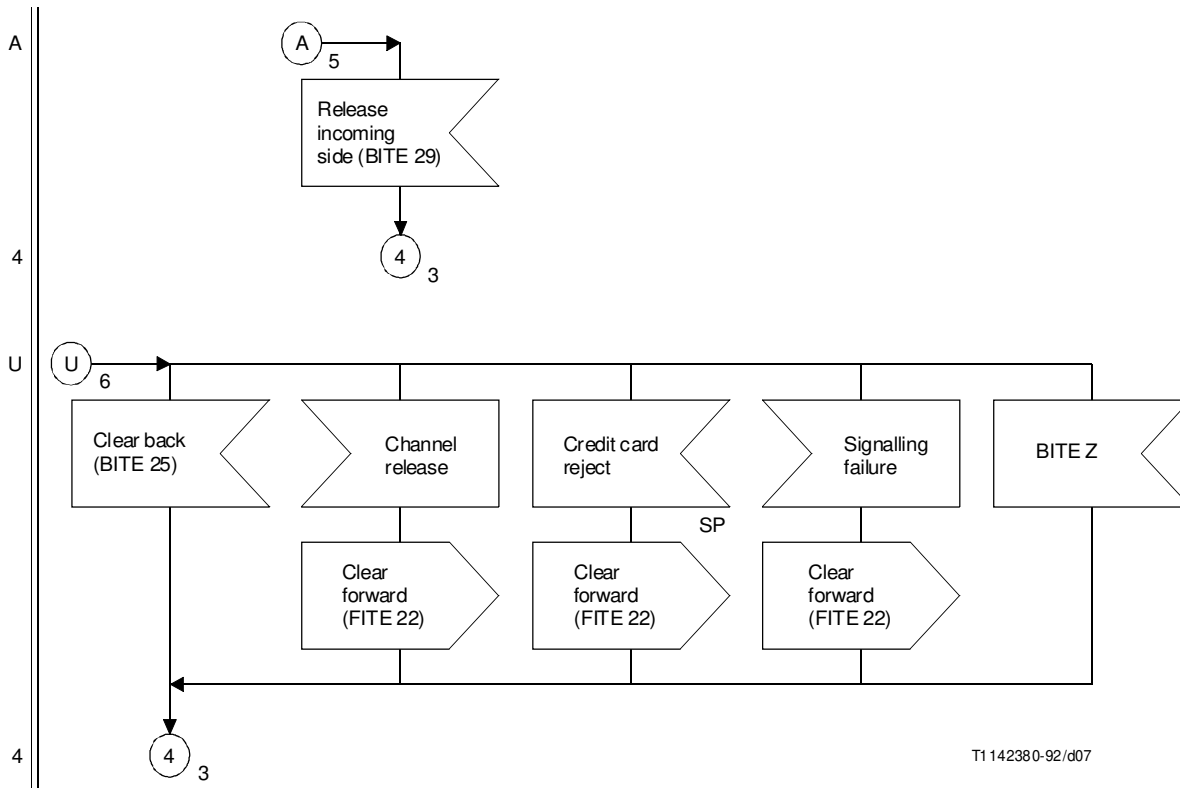

T1 142380-92/d07

FIGURE 1/Q.1152 (sheet 7 of 7)
Logic procedures for incoming INMARSAT aeronautical signalling (air-to-ground calls)

4.2 The MSSC attempts to assign a satellite channel to the call, and tests for continuity of the channel. National network congestion (BITE 12) signal is returned if no channel is available. Appropriate signals are returned to signify continuity failure and AES busy conditions.

4.3 Answer signal is returned when the connect message is received from the AES.

4.4 The call is cleared down in the usual manner, on receipt of either clear forward from the interworking process, or channel release from the AES.

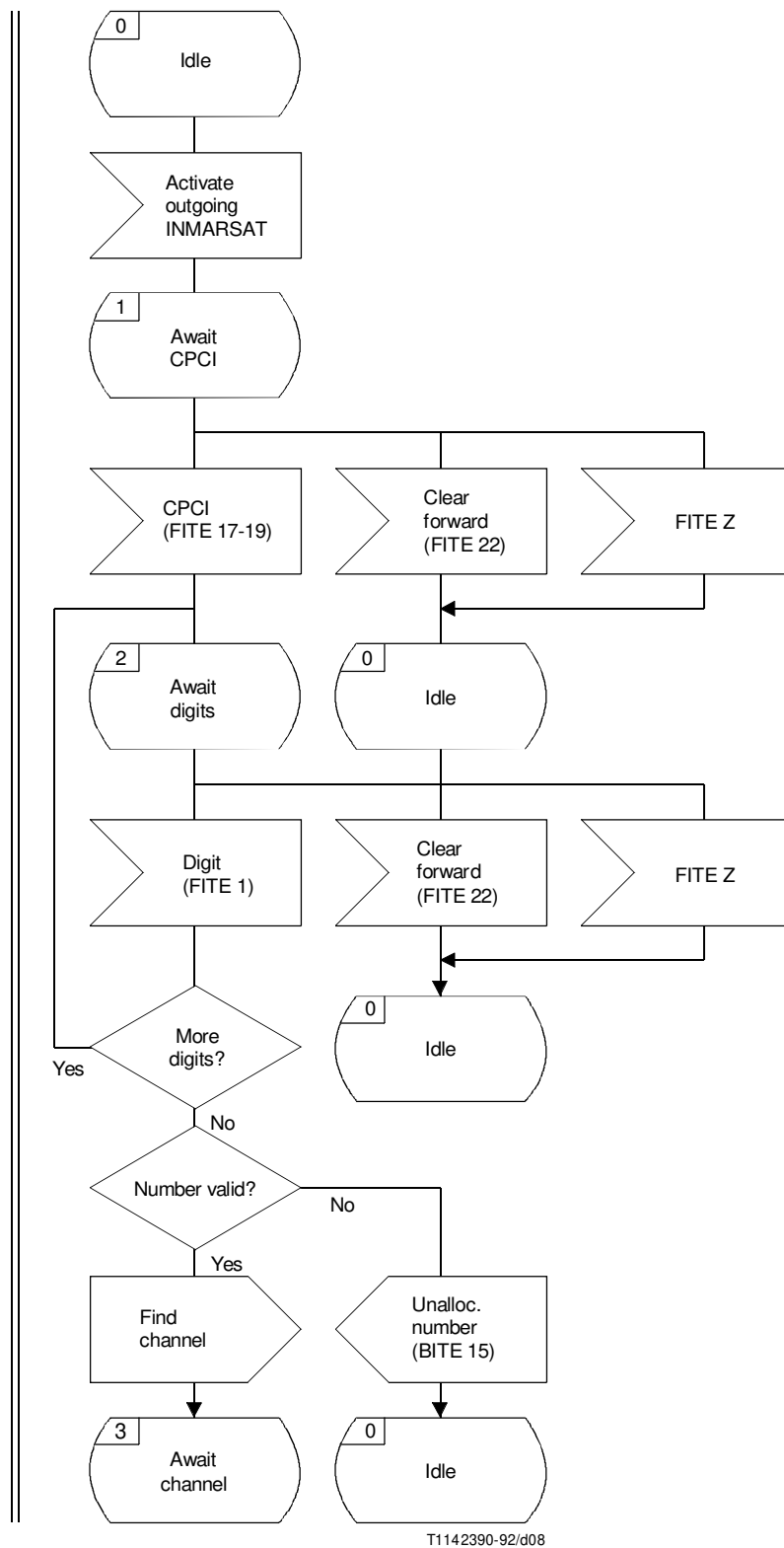

T1142390-92/d08

NOTE – Number valid? means is the AES in the region of the calling GES; i.e. logged on the same satellite.

FIGURE 2/Q.1152 (sheet 1 of 4)
**Logic procedures for outgoing INMARSAT aeronautical signalling
 (ground-to-air-calls)**

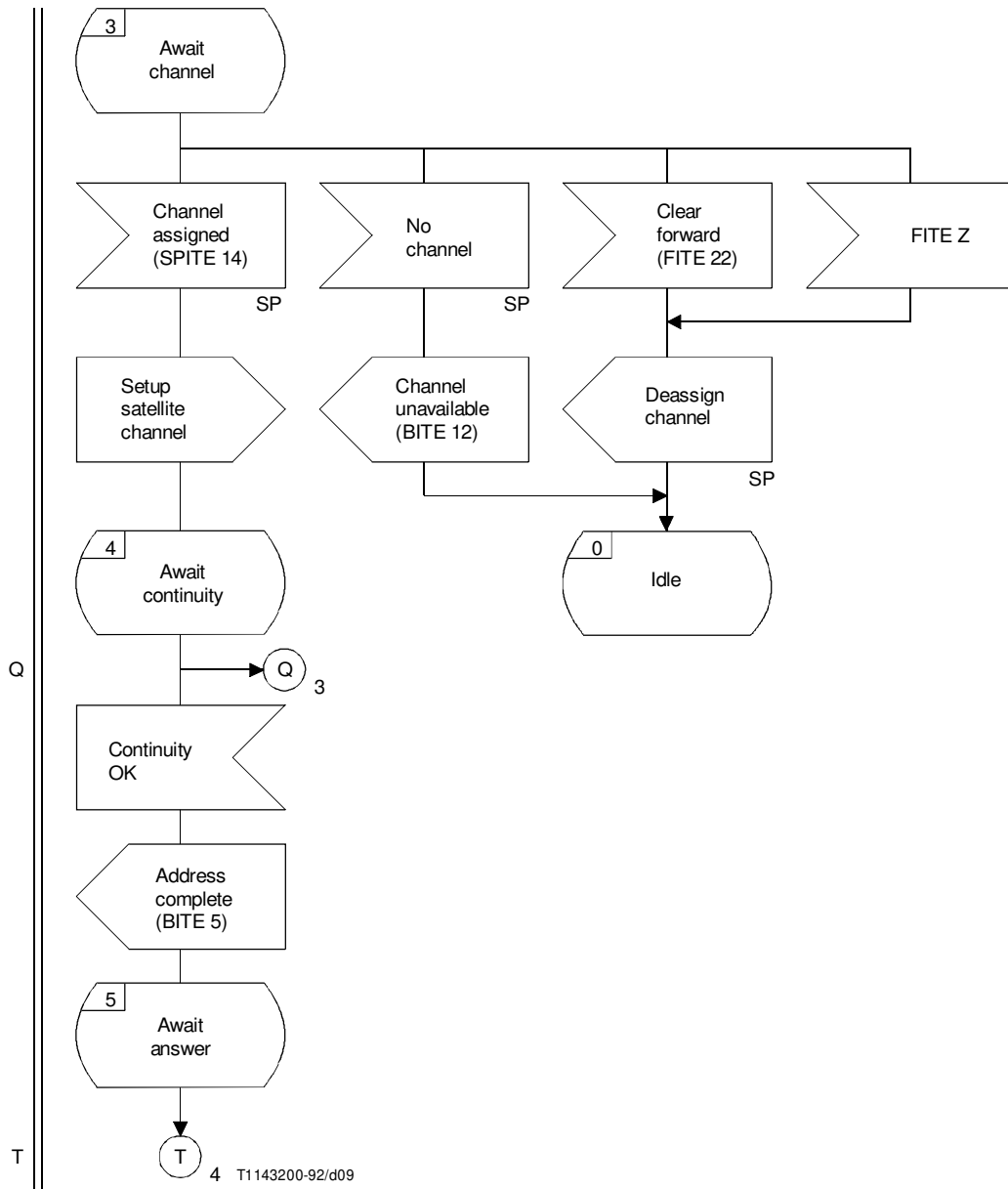

FIGURE 2/Q.1152 (sheet 2 of 4)

**Logic procedures for outgoing INMARSAT aeronautical signalling
(ground-to-air-calls)**

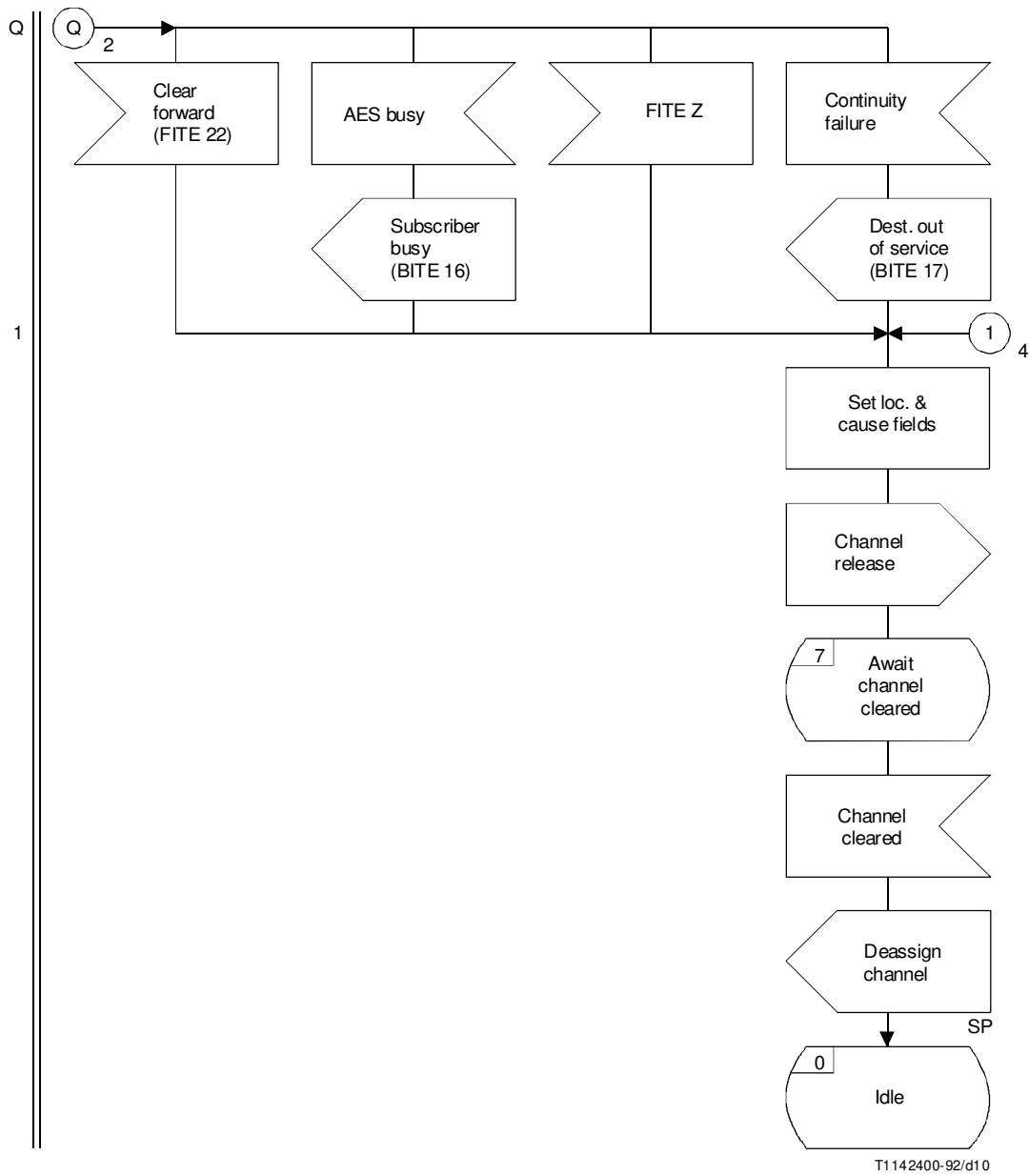

FIGURE 2/Q.1152 (sheet 3 of 4)
**Logic procedures for outgoing INMARSAT aeronautical signalling
 (ground-to-air-calls)**

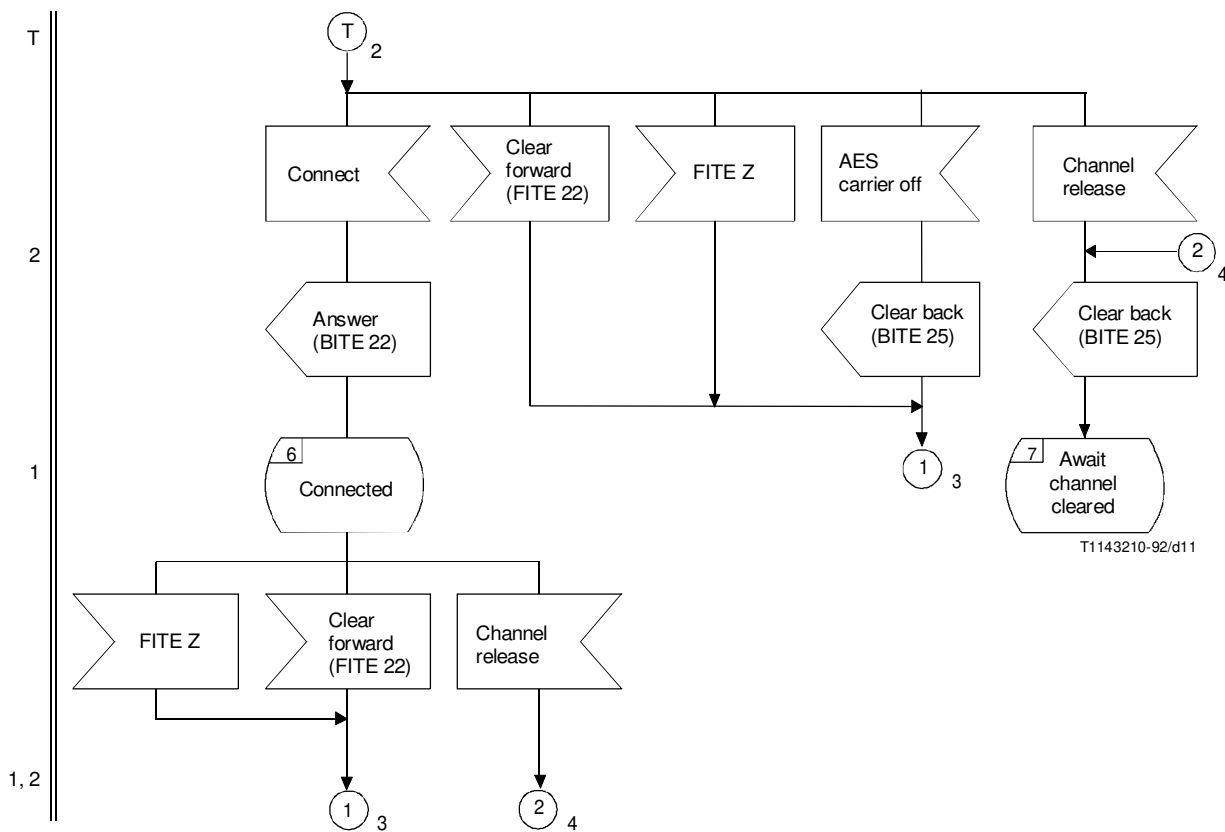

FIGURE 2/Q.1152 (sheet 4 of 4)
**Logic procedures for outgoing INMARSAT aeronautical signalling
 (ground-to-air-calls)**

5 Interworking of INMARSAT aeronautical signalling system with itself

Figure 3 contains the procedures for interworking between the incoming and outgoing procedures of the INMARSAT aeronautical system. These procedures may also apply for interworking between INMARSAT aeronautical and the Standard-A and Standard-B systems.

The following details should be noted:

- 5.1 The outgoing INMARSAT aeronautical logic process is activated after receipt of the calling party category information, indicating whether the call is ordinary or priority.
- 5.2 The called party address, excluding the INMARSAT country code, is transferred to the outgoing process. The process returns to idle on receipt of any unsuccessful BITE or the clear forward FITE.
- 5.3 The call is cleared as normal, on either clearforward FITE or clearback BITE signals.
- 5.4 The interworking procedure supervises the answer time (timer t1). The value of the timer is as follows:
 $t1 = 2 \text{ to } 4 \text{ minutes (as per 4.3.1/Q.118)}$.

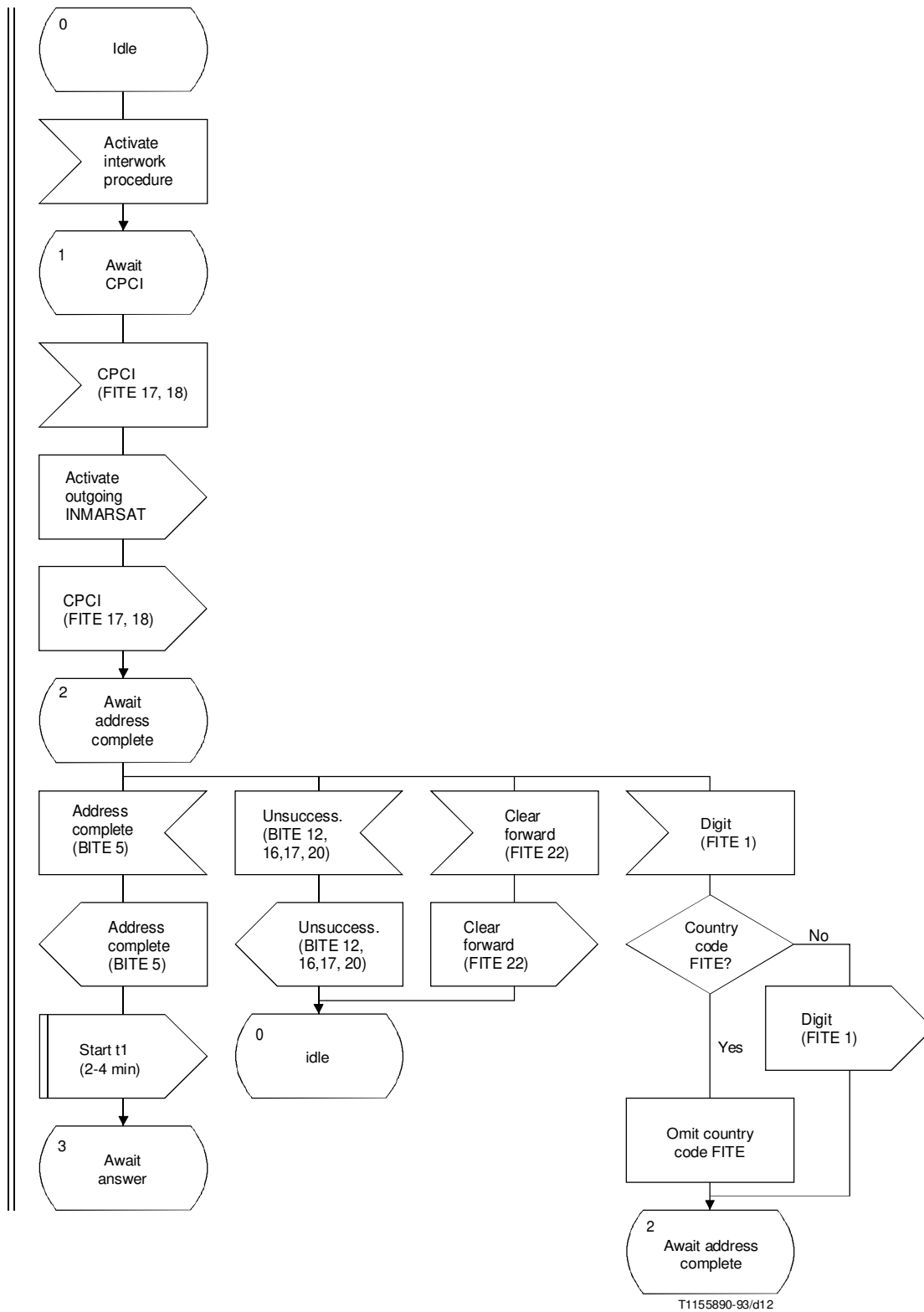

FIGURE 3/Q.1152 (sheet 1 of 2)
Interworking of INMARSAT aeronautical system with itself

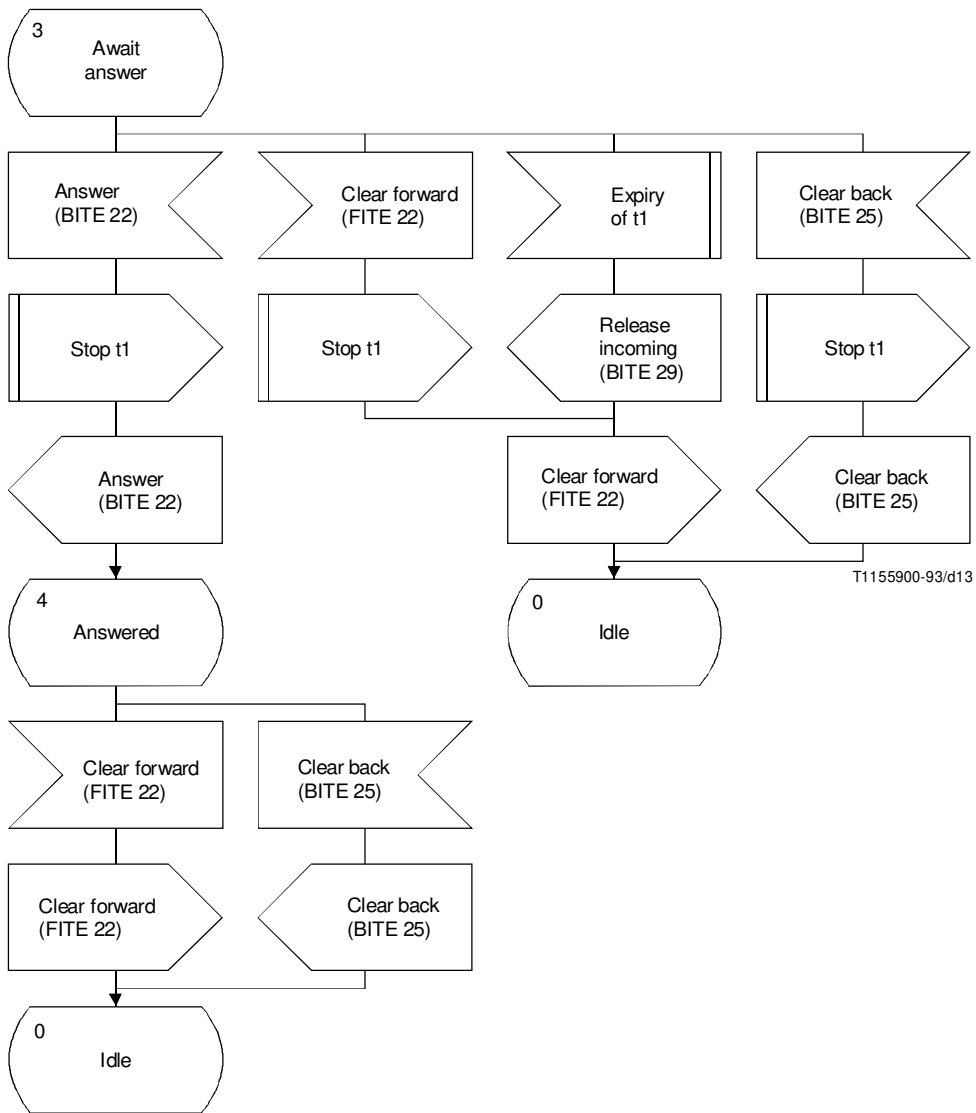

FIGURE 3/Q.1152 (sheet 2 of 2)
Interworking of INMARSAT aeronautical system with itself

6 Interworking of incoming INMARSAT aeronautical to Signalling System R2

6.1 Figure 4 contains the procedures for interworking of INMARSAT aeronautical signalling system to Signalling System R2.

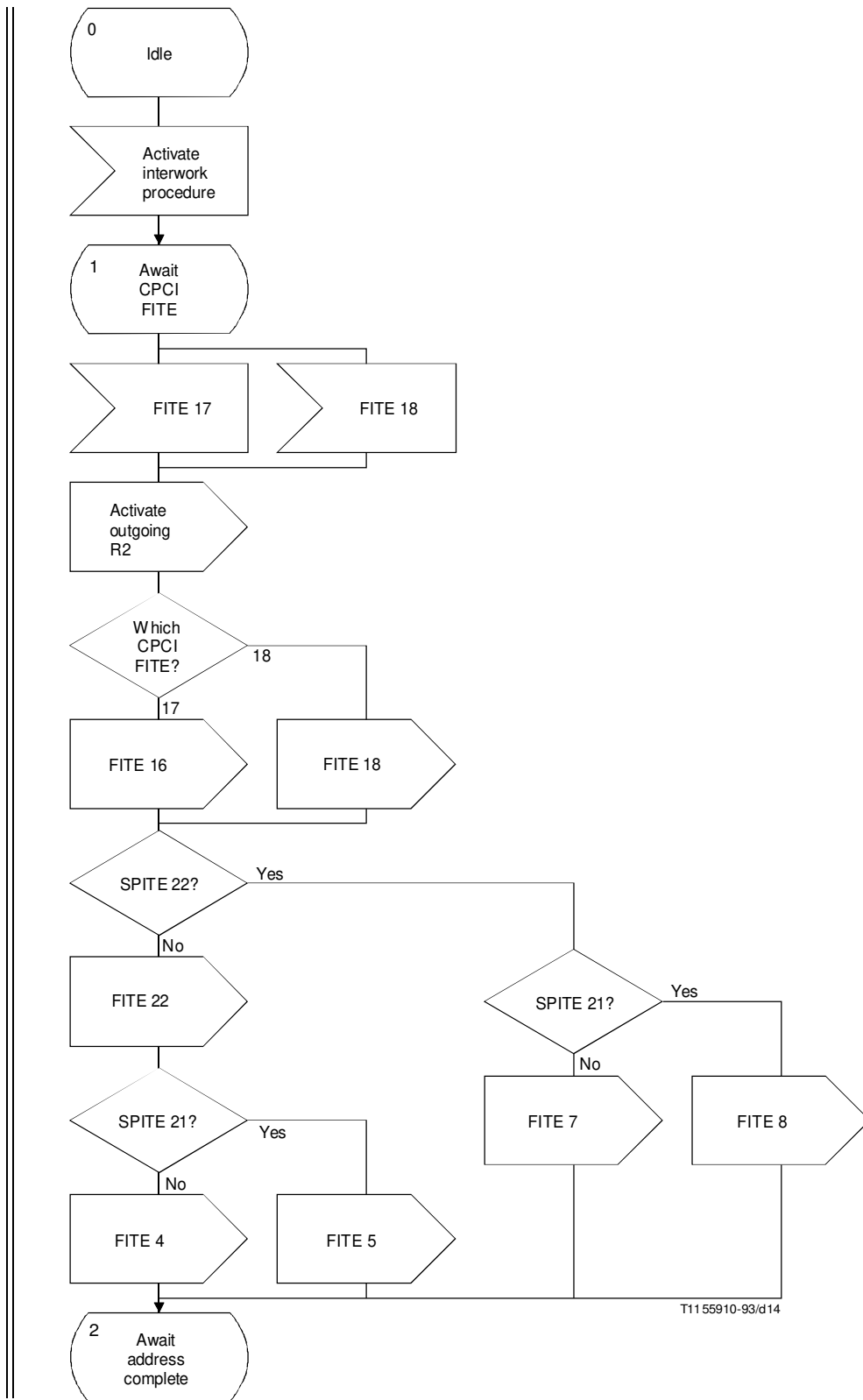
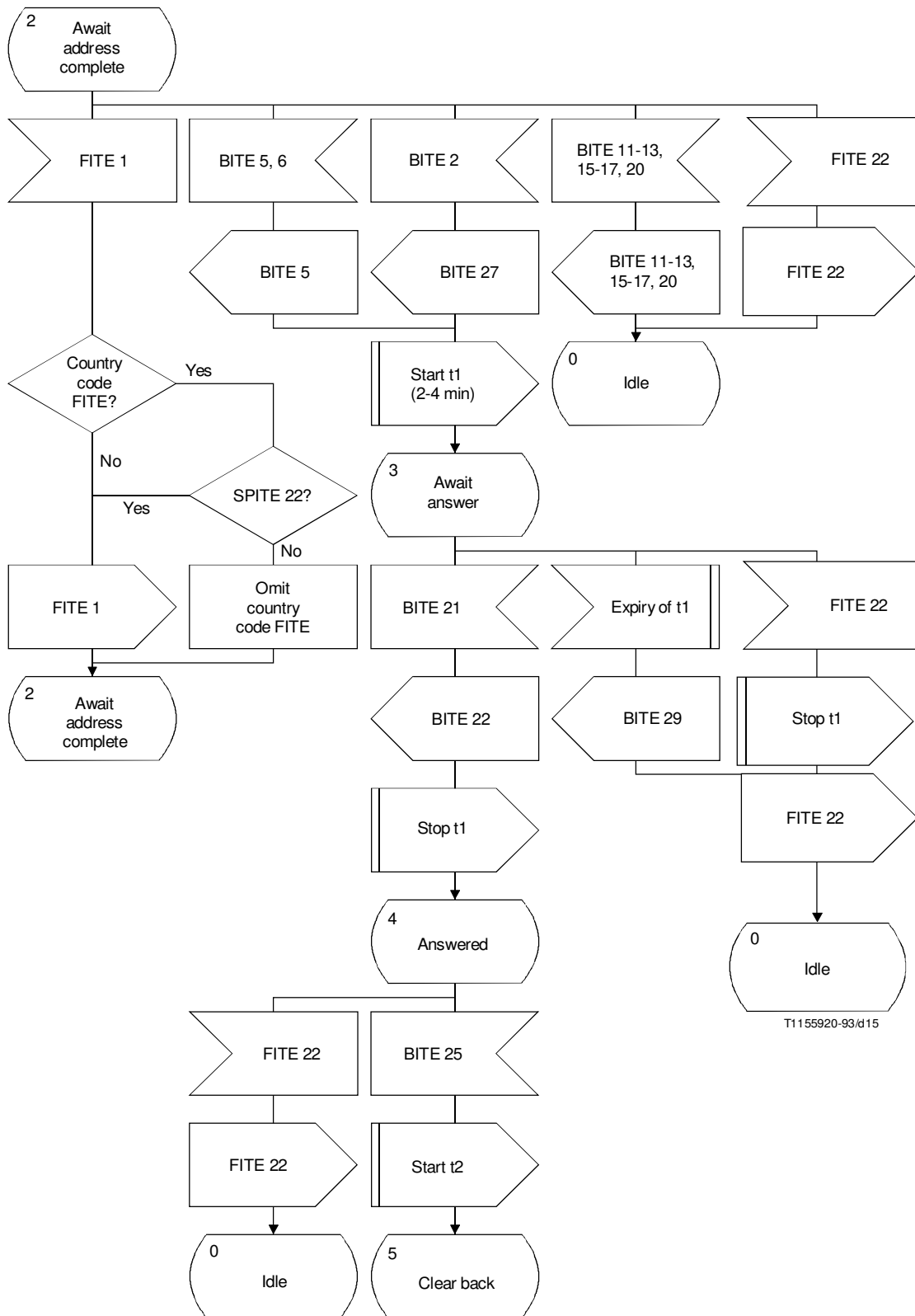

FIGURE 4/Q.1152 (sheet 1 of 3)
 Interworking of INMARSAT aeronautical system to Signalling System R2



T1155920-93/d15

FIGURE 4/Q.1152 (sheet 2 of 3)
 Interworking of INMARSAT aeronautical system to Signalling System R2

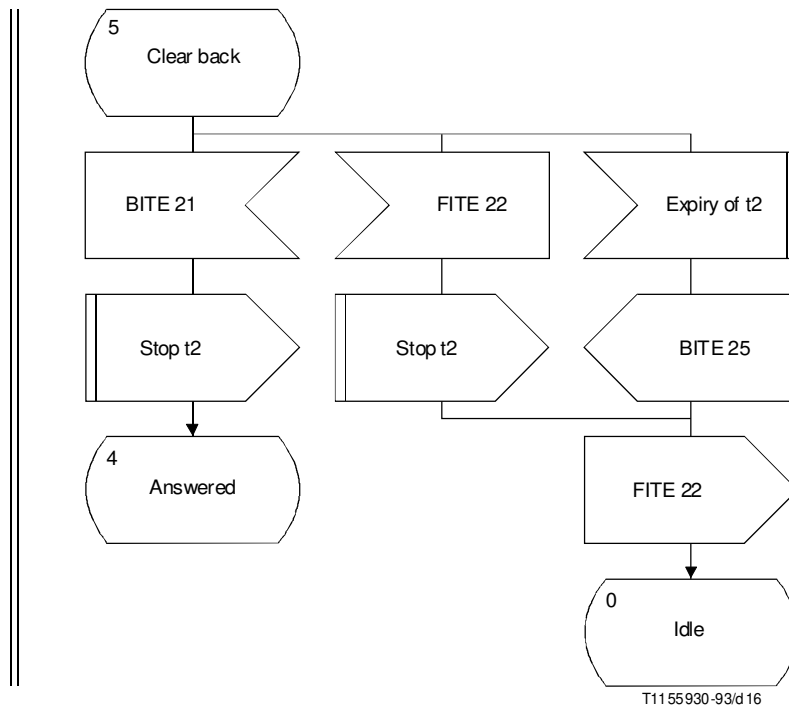

FIGURE 4/Q.1152 (sheet 3 of 3)
**Interworking of INMARSAT aeronautical system
 to Signalling System R2**

6.2 The interworking procedure supervises the answer time and the clearback time, with timers t1 and t2 respectively. The values of the timers are as follows:

t1 = 2 to 4 minutes (as per 4.3.1/Q.118)

t2 = 1 to 2 minutes (as per 4.3.2/Q.118).

7 Interworking of Signalling System R2 to outgoing INMARSAT aeronautical

7.1 Figure 5 contains the procedures for interworking of Signalling System R2 to INMARSAT aeronautical signalling system.

7.2 The ringing tone towards the calling subscriber of the fixed network is initiated by the interworking procedure. The tone should have characteristics in accordance with Recommendation Q.35.

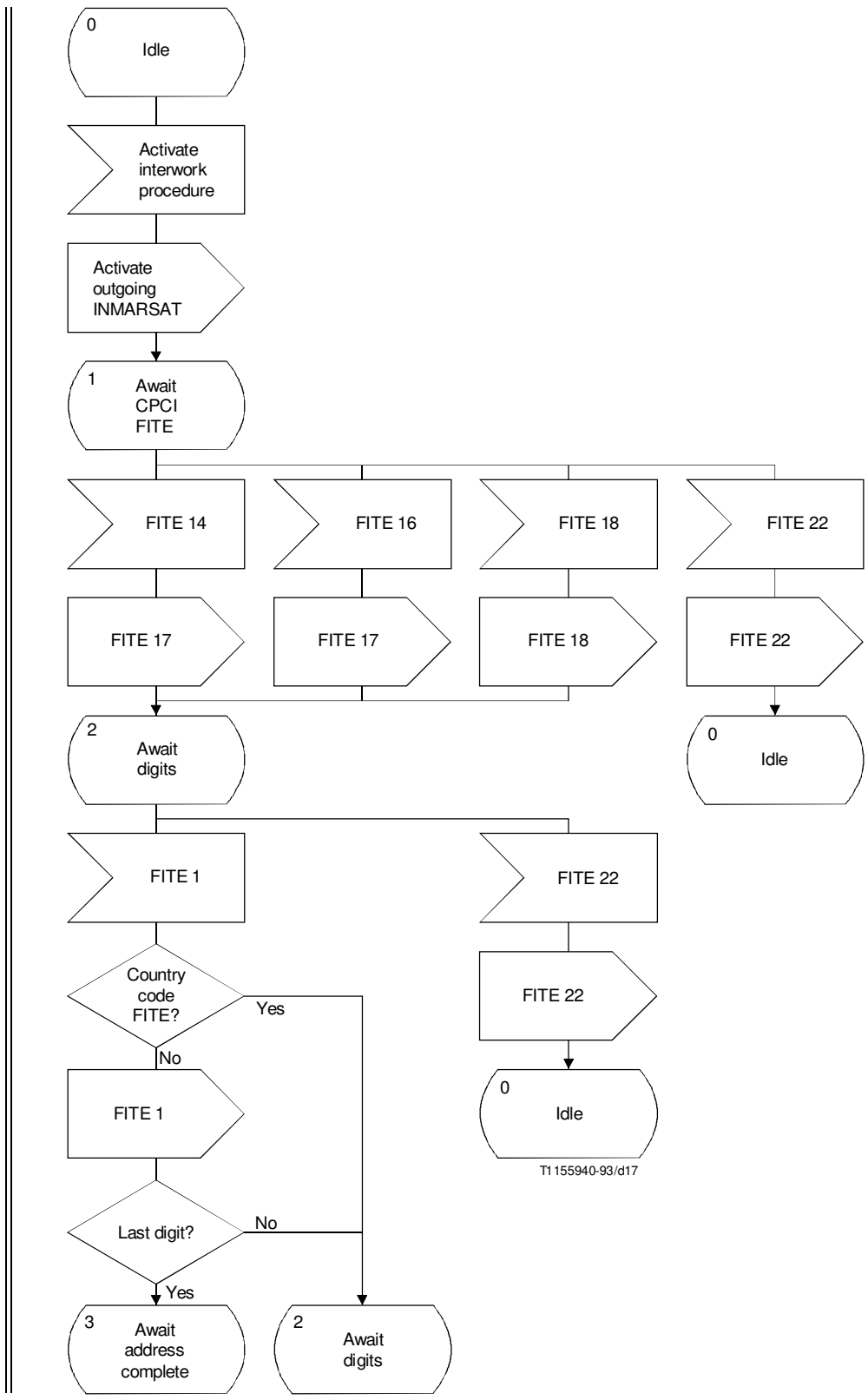

T1 155940-93/d17

FIGURE 5/Q.1152 (sheet 1 of 2)
 Interworking of Signalling System R2 to INMARSAT aeronautical system

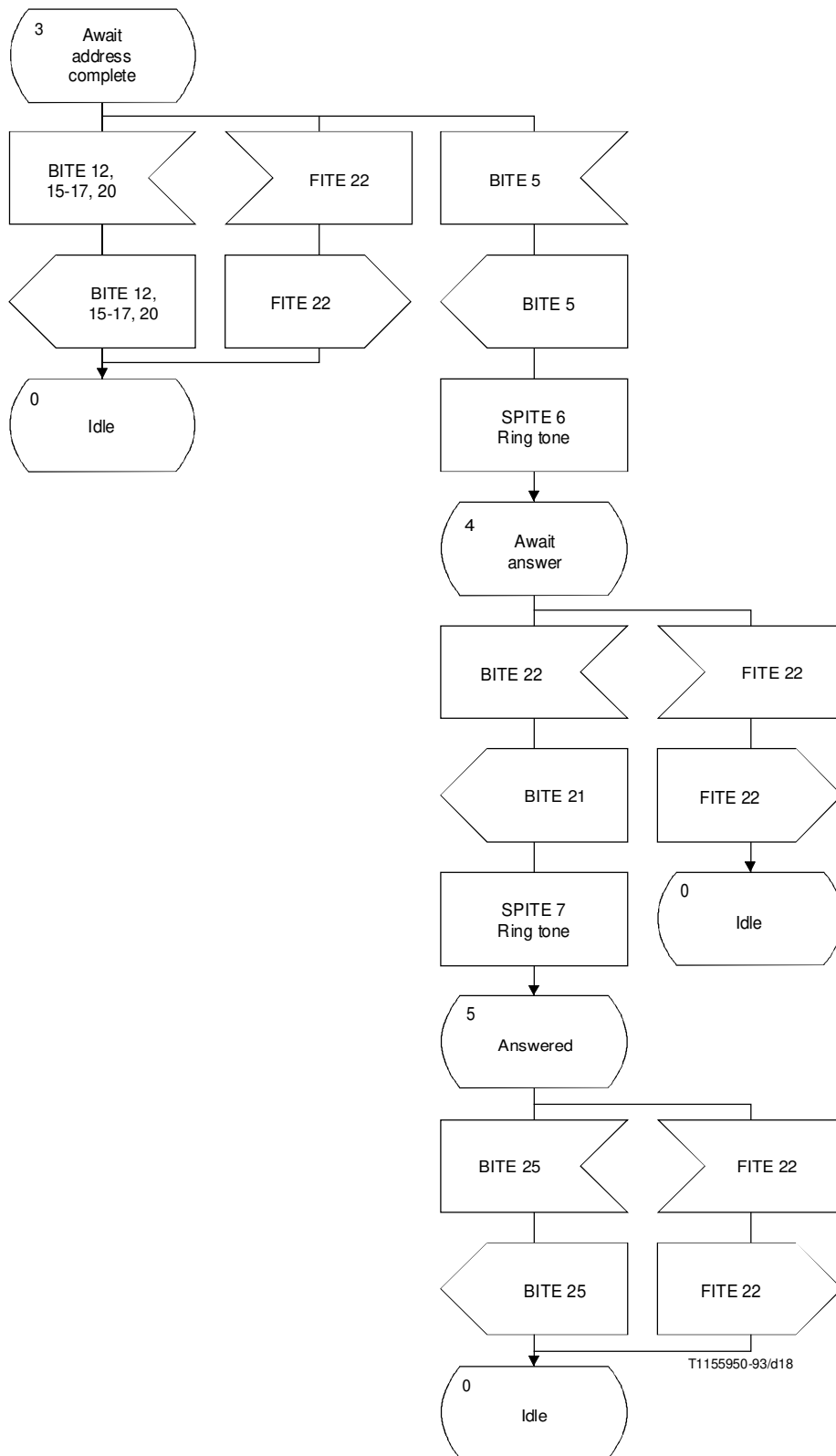

T1155950-93/d18

FIGURE 5/Q.1152 (sheet 2 of 2)
 Interworking of Signalling System R2 to INMARSAT aeronautical system

8 Interworking of incoming INMARSAT aeronautical to Signalling System No. 7 (TUP)

Figure 6 contains the procedures for interworking of INMARSAT aeronautical signalling system to Signalling System No. 7 (TUP).

The following details should be noted:

8.1 The outgoing Signalling System No. 7 (TUP) is activated only after receipt of calling party category information.

8.2 Signals to inform whether continuity checking is required on the terrestrial link, whether an incoming half-echo suppressor should be inserted, and whether country code digits will be sent along with the called party address, are sent to the ISC. The ISC is also informed that continuity has been proven on the satellite link.

8.3 All address-complete backward signals are transferred through to the outgoing aeronautical procedure. The charge related information is interpreted and used by the MSSC for billing purposes, and a simple address complete message is sent to the AES.

8.4 All unsuccessful call indications received from the ISC are relayed to the INMARSAT system, by means of the call attempt result message with the cause value set appropriately.

8.5 Charge information contained in the answer message is again used by the MSSC for billing purposes.

8.6 Answer and clearback supervision is done by the MSSC with timers t1 and t2 respectively. The values of the timers are as follows:

t1 = 2 to 4 minutes (as per 4.3.1/Q.118)

t2 = 1 to 2 minutes (as per 4.3.2/Q.118).

9 Interworking of Signalling System No. 7 (TUP) to outgoing INMARSAT aeronautical

Figure 7 contains the procedures for interworking of Signalling System No. 7 (TUP) to INMARSAT aeronautical signalling system.

The following details should be noted:

9.1 Calling party category information indicating the nature and priority of the call, is transferred through to the aeronautical system. The operator language indicator is interpreted and used by the MSSC.

9.2 The entire called party address, except the country code digits, are transferred through to the aeronautical system. The outgoing aeronautical logic process determines the validity of the addressed AES, and returns an unsuccessful call indication if necessary.

9.3 The call may also be aborted if:

- no satellite voice channels are available;
- the addressed AES subscriber is busy;
- the continuity check is unsuccessful.

9.4 The MSSC returns audible ring tone, as per provisions in Recommendation Q.35, to the terrestrial network. The tone is applied on receipt of the address complete message from the AES, and removed upon receipt of the connect message.

Connector reference

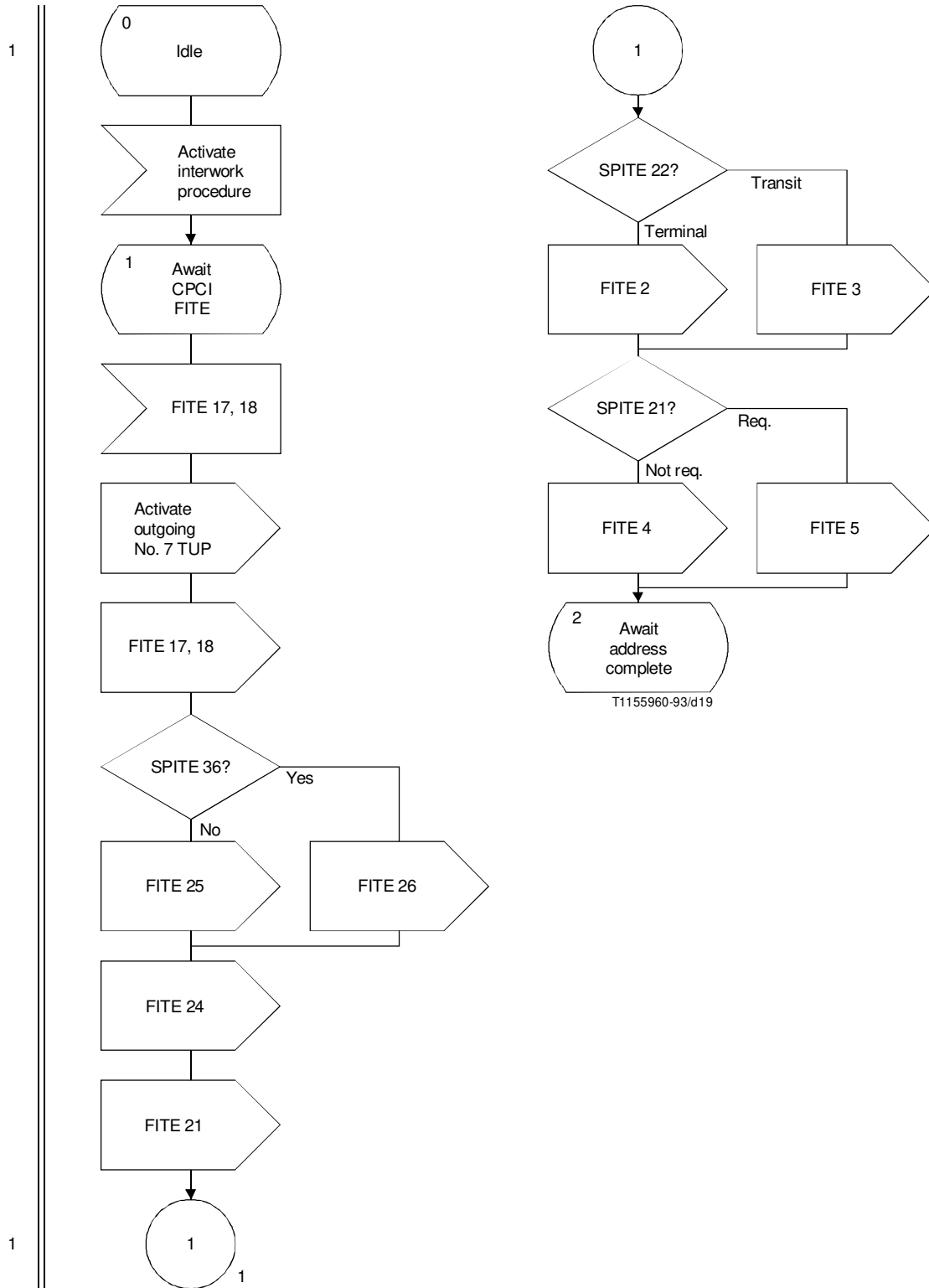

FIGURE 6/Q.1152 (sheet 1 of 3)

Interworking of INMARSAT aeronautical system to Signalling System No. 7 TUP

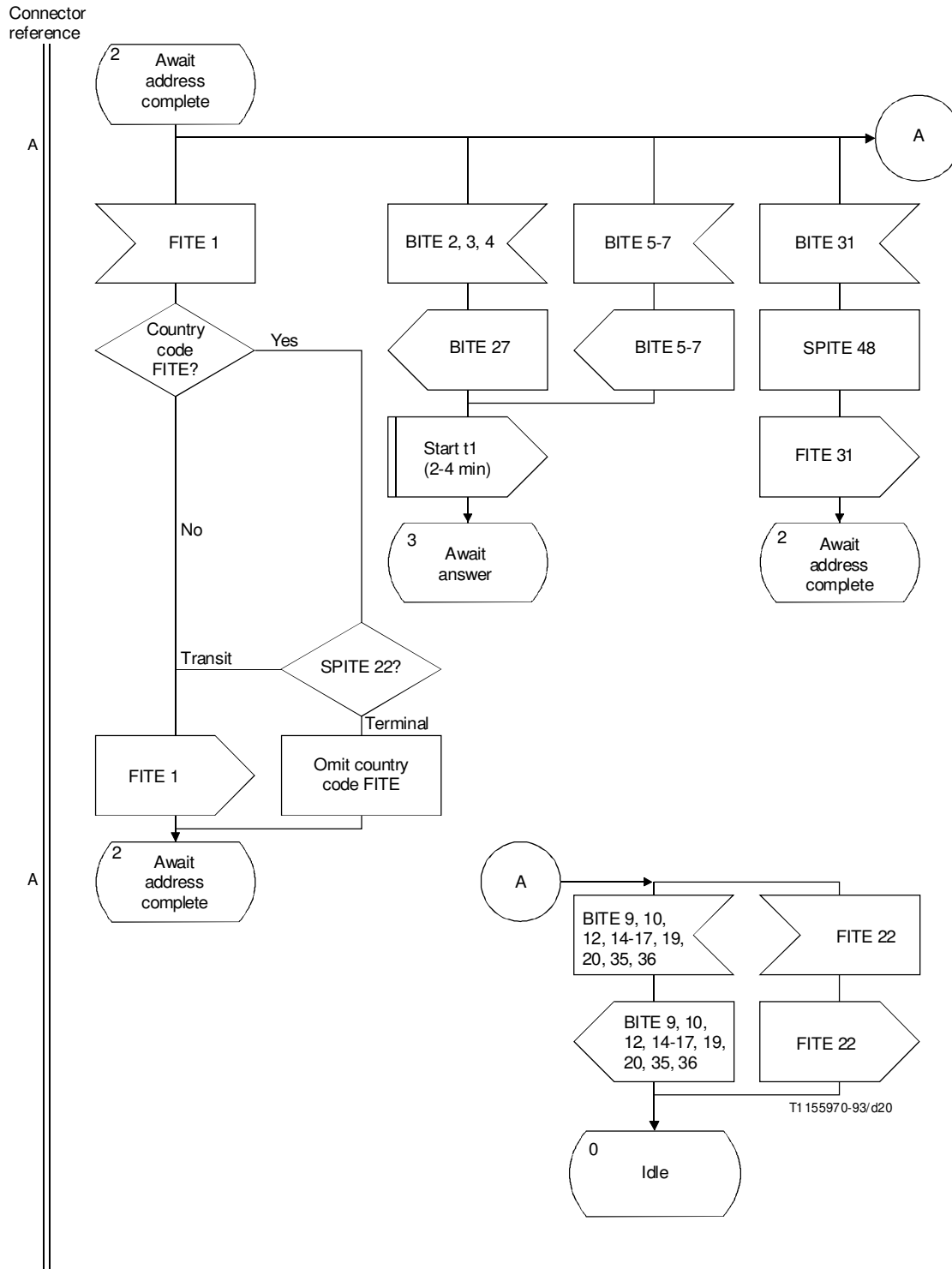

FIGURE 6/Q.1152 (sheet 2 of 3)

Interworking of INMARSAT aeronautical system to Signalling System No. 7 TUP

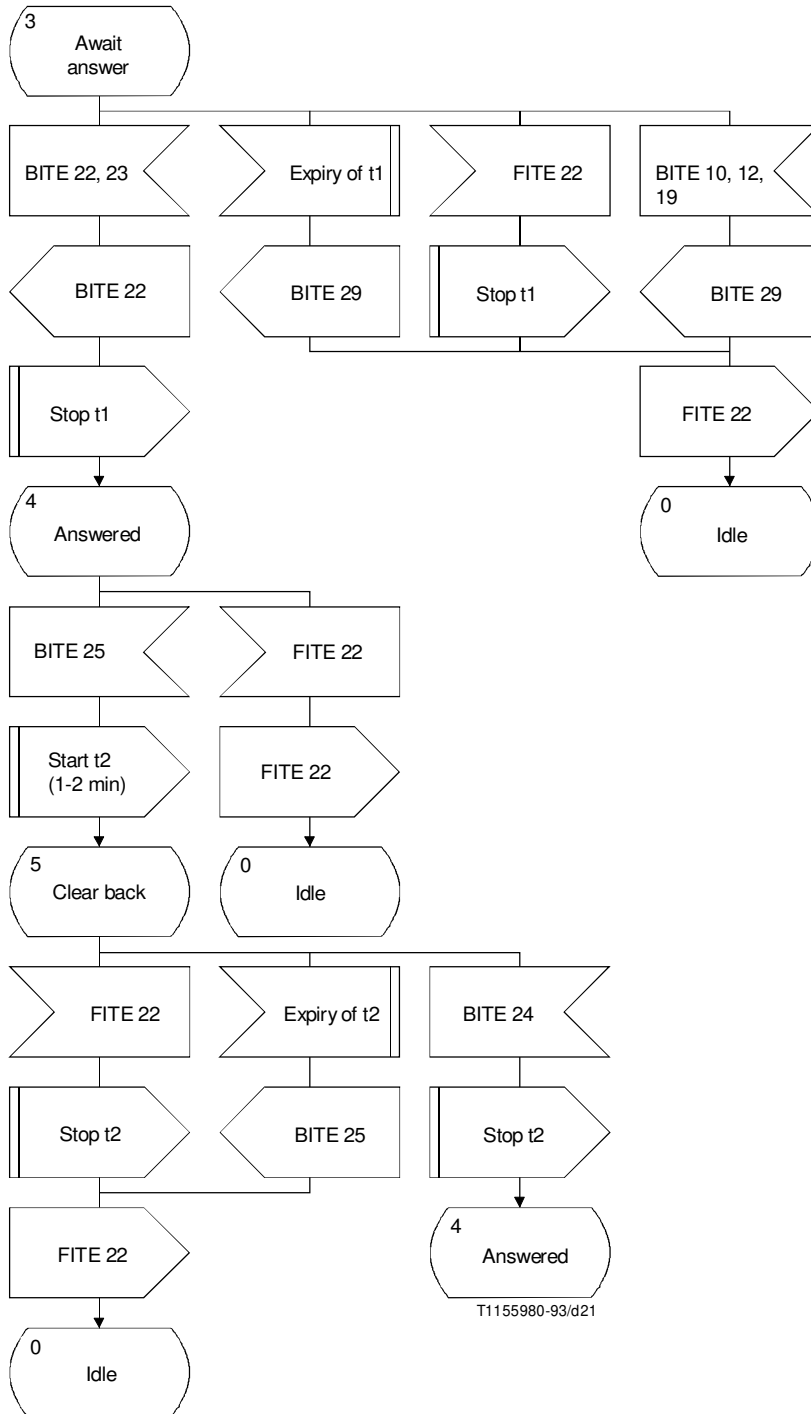

FIGURE 6/Q.1152 (sheet 3 of 3)
Interworking of INMARSAT aeronautical system to Signalling System No. 7 TUP

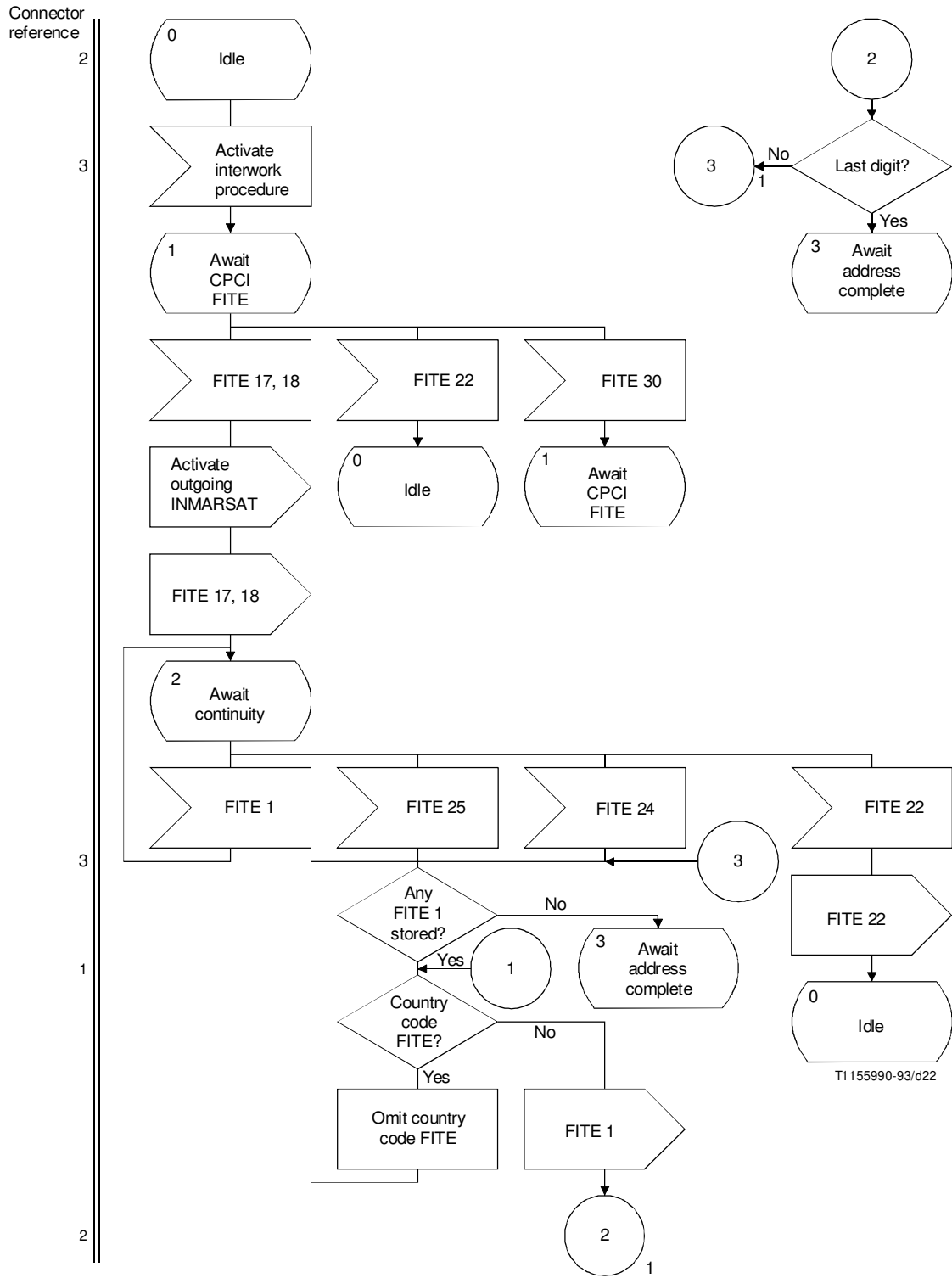

FIGURE 7/Q.1152 (sheet 1 of 2)

Interworking of Signalling System No. 7 TUP to INMARSAT aeronautical system

Connector reference

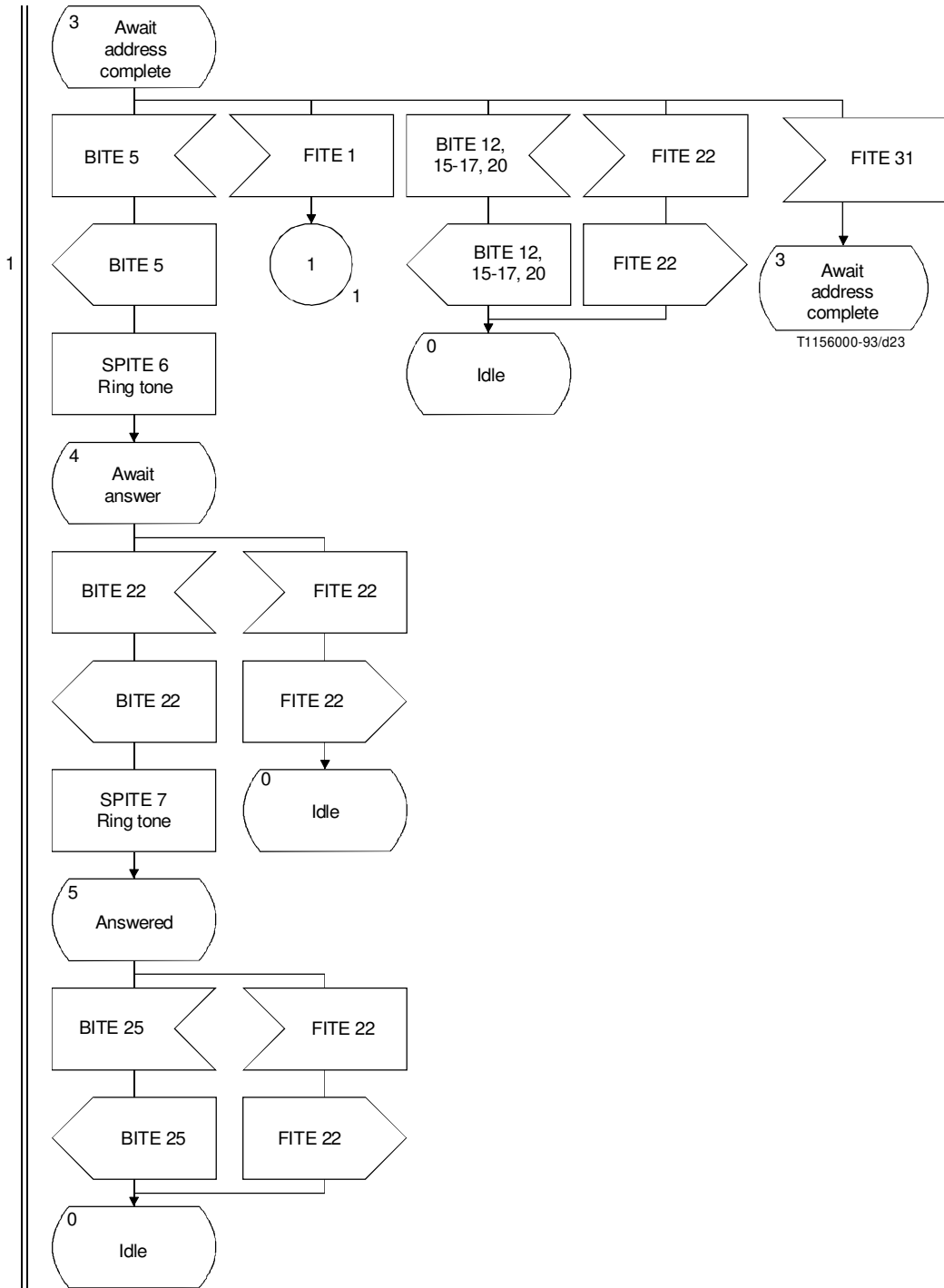

FIGURE 7/Q.1152 (sheet 2 of 2)

Interworking of Signalling System No. 7 TUP to INMARSAT aeronautical system

10 Interworking of incoming INMARSAT aeronautical to Signalling System No. 5

Figure 8 contains the procedures for interworking of INMARSAT aeronautical signalling system to Signalling System No. 5.

10.1 The outgoing Signalling System No. 5 procedure is activated after receipt of the calling party category information, in the access request message from the AES.

10.2 Either KP2 or KP1 signal is sent by the MSSC, depending on whether the country code is to be outpulsed or not, respectively.

10.3 The artificial “send-finished” signal, received from the outgoing Signalling System No. 5 procedure, is interpreted as an address complete condition to convey back to the AES.

10.4 The “busy-flash” signal (unsuccessful call) received from the terrestrial network is transferred to the AES by means of the call attempt result message.

10.5 Answer and clearback timeout supervision is done by the MSSC, with timers t1 and t2, respectively. The values of the timers are as follows:

t1 = 2 to 4 minutes (as per 4.3.1/Q.118)

t2 = 1 to 2 minutes (as per 4.3.2/Q.118).

11 Interworking of Signalling System No. 5 to outgoing INMARSAT aeronautical

Figure 9 contains the procedures for interworking of Signalling System No. 5 INMARSAT aeronautical signalling system.

The following details should be noted:

11.1 The KP2 or KP1 signal is received from the MSSC, depending on whether the country code is to be expected along with the called party address or not, respectively.

11.2 The “busy-flash” signal is sent to the ISC if the call cannot be completed for any of the following reasons:

- called AES subscriber is busy;
- no satellite channel is available;
- the continuity check is unsuccessful.

The special information tone is sent back to the ISC, if the call is unsuccessful for any other reasons.

11.3 Answer and clearback signals received from the AES are conveyed through to the terrestrial network as soon as they are received, and there is no timeout supervision required.

Addendum – A recent change in the INMARSAT signalling system definition allows cause information to be carried in the channel release signal, thereby making it unnecessary to send the call attempt result signal for unsuccessful calls. The interworking procedures in this Recommendation do not reflect this change.

12 Figure 10 contains the procedures for the interworking of Signalling System No. 7 (ISUP) to the INMARSAT aeronautical signalling system.

13 Figures 11, 12 and 13 contain the procedures for the interworking of INMARSAT aeronautical signalling system to Signalling System No. 7.

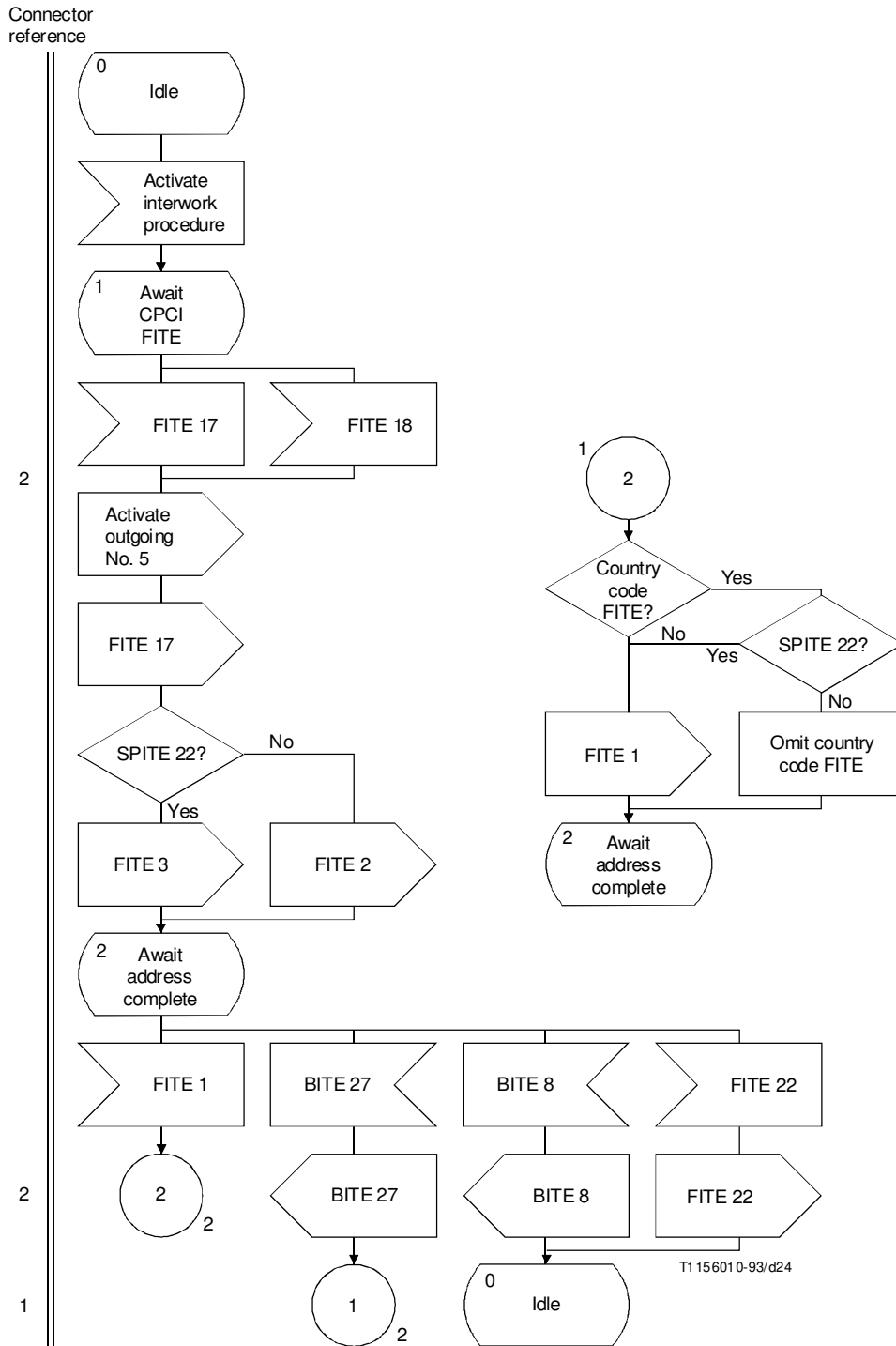
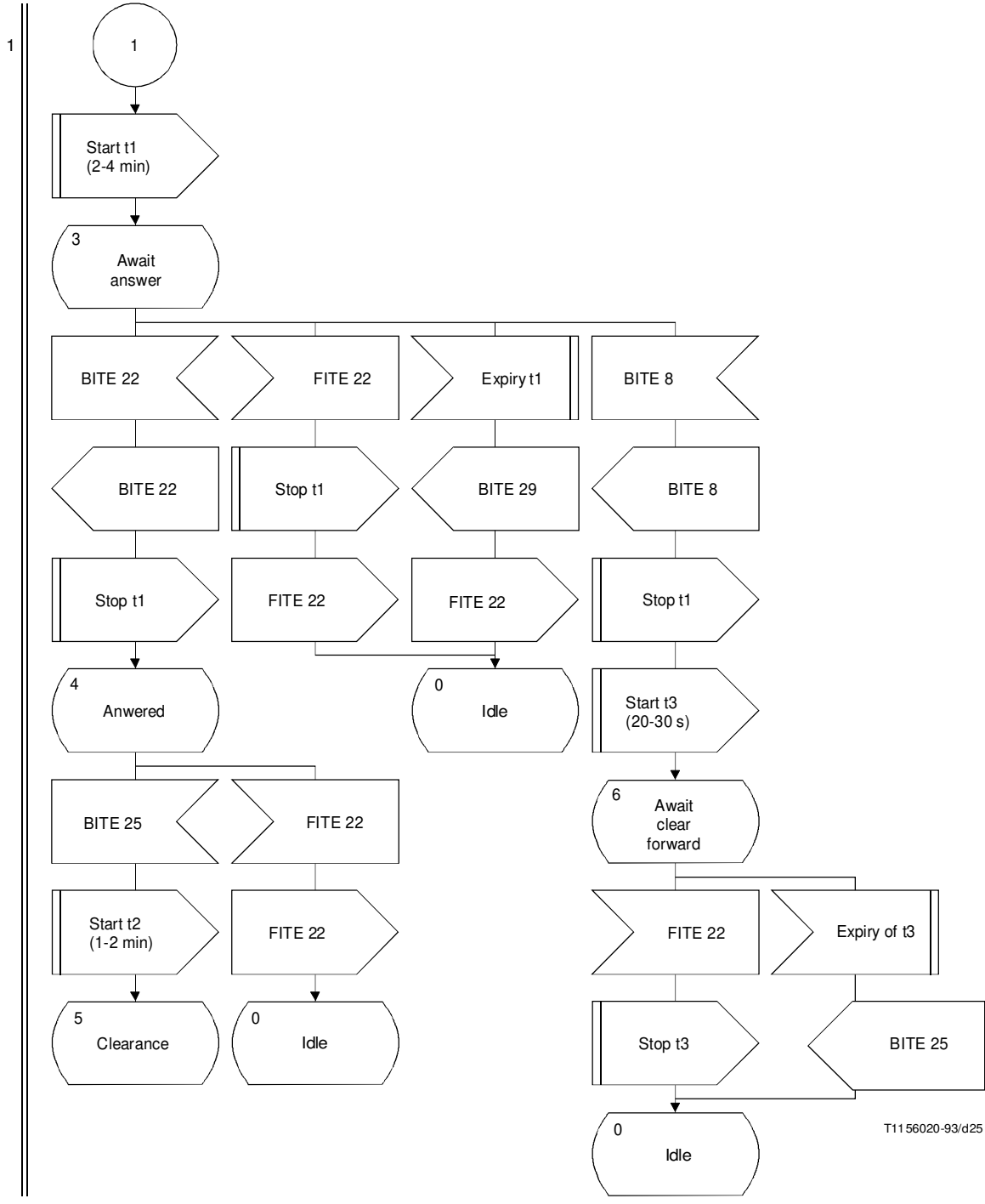

FIGURE 8/Q.1152 (sheet 1 of 3)

Interworking of INMARSAT aeronautical system to Signalling System No. 5

Connector reference



T1156020-93/d25

FIGURE 8/Q.1152 (sheet 2 of 3)
Interworking of INMARSAT aeronautical system to Signalling System No. 5

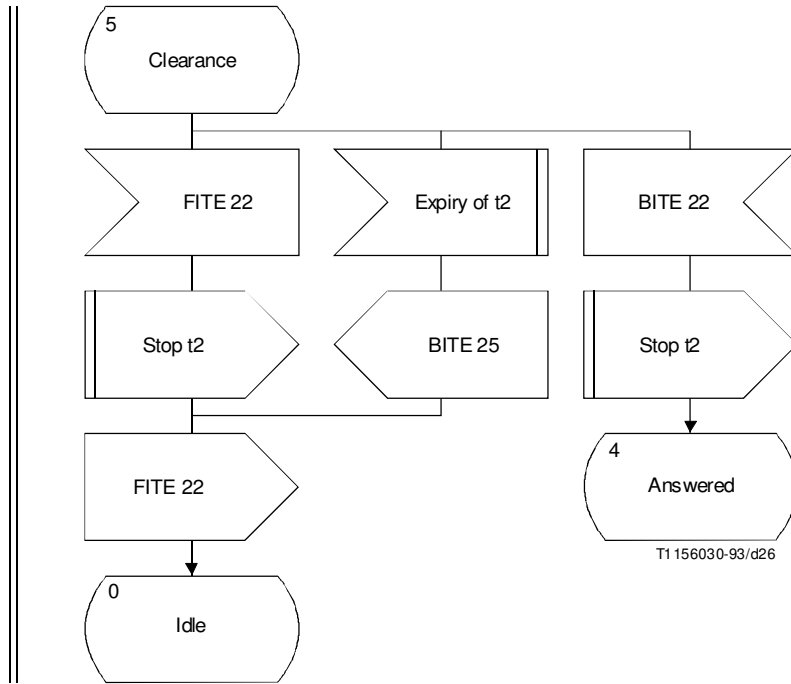

FIGURE 8/Q.1152 (sheet 3 of 3)
Interworking of INMARSAT aeronautical system to Signalling System No. 5

Connector reference

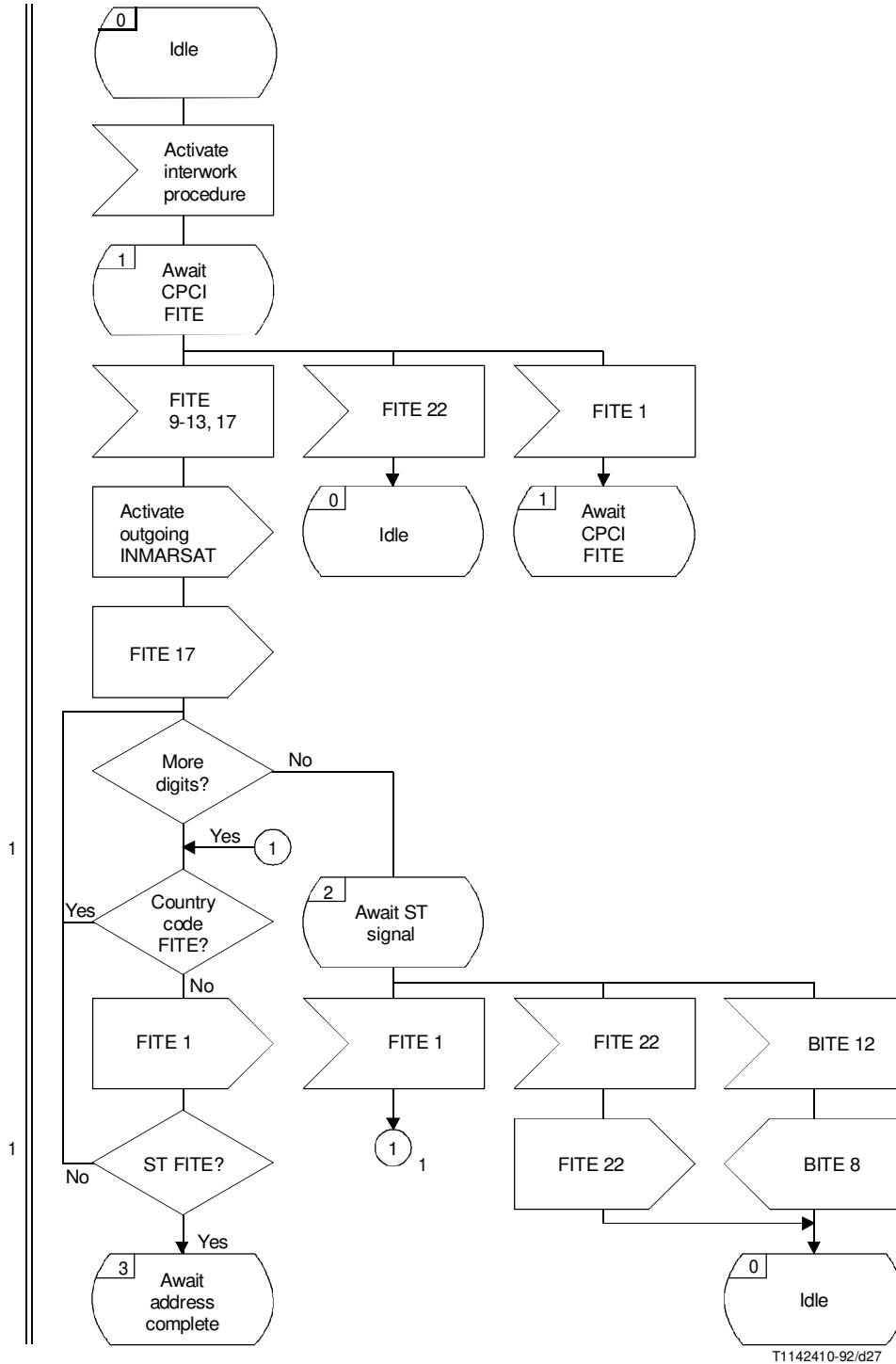

FIGURE 9/Q.1152 (sheet 1 of 2)

Interworking of Signalling System No. 5 to INMARSAT aeronautical system

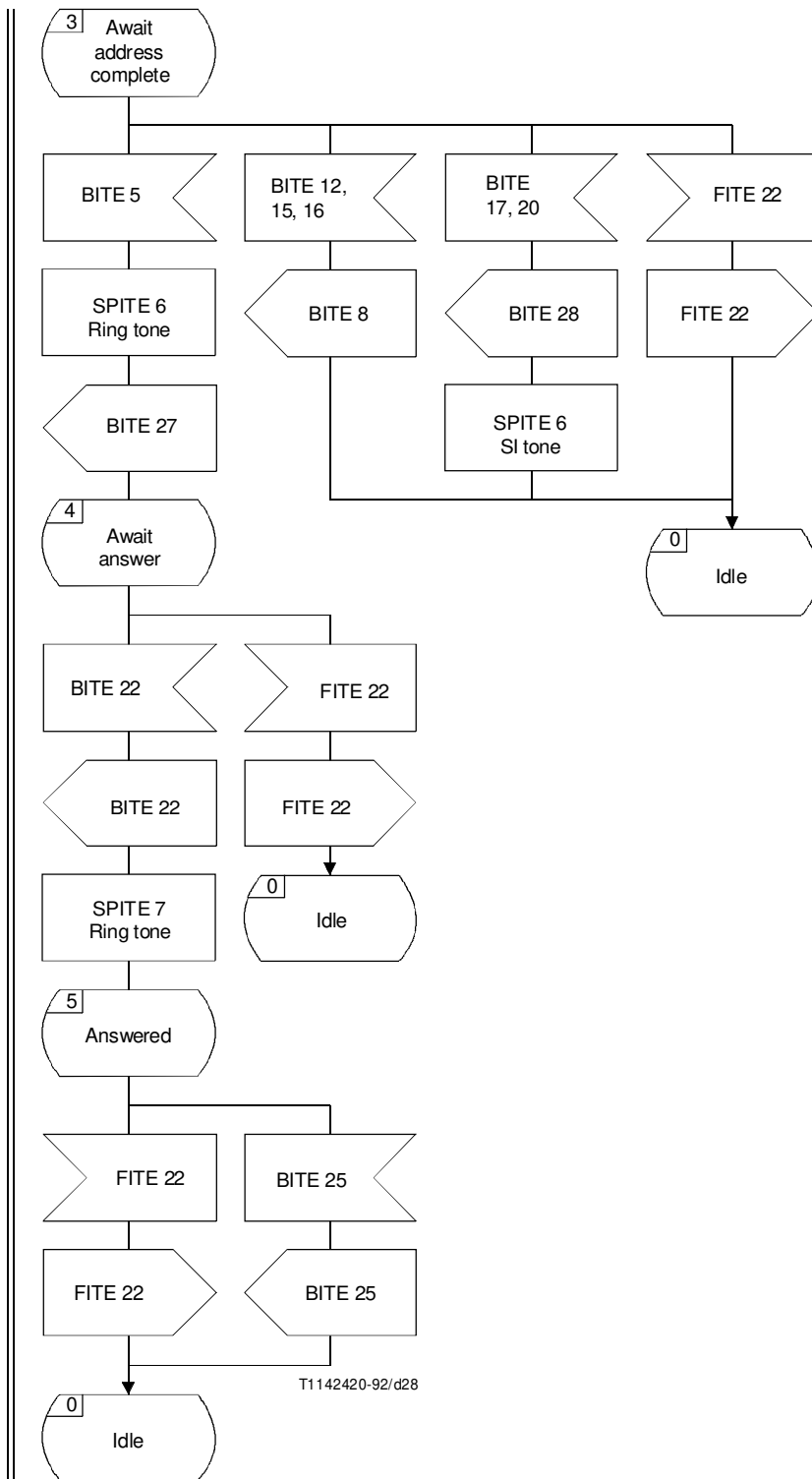
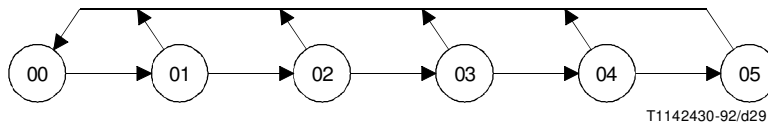

FIGURE 9/Q.1152 (sheet 2 of 2)
**Interworking of Signalling System No. 5
 to INMARSAT aeronautical system**



State number	State description	Sheet reference
00	Idle	1
01	Wait for call set-up information	1
02	Await continuity	2
03	Wait for address complete	3
04	Wait for answer	4
05	Answered	4

FIGURE 10/Q.1152
**State overview diagram for interworking of Signalling
 System No. 7 ISUP to INMARSAT-Aero**

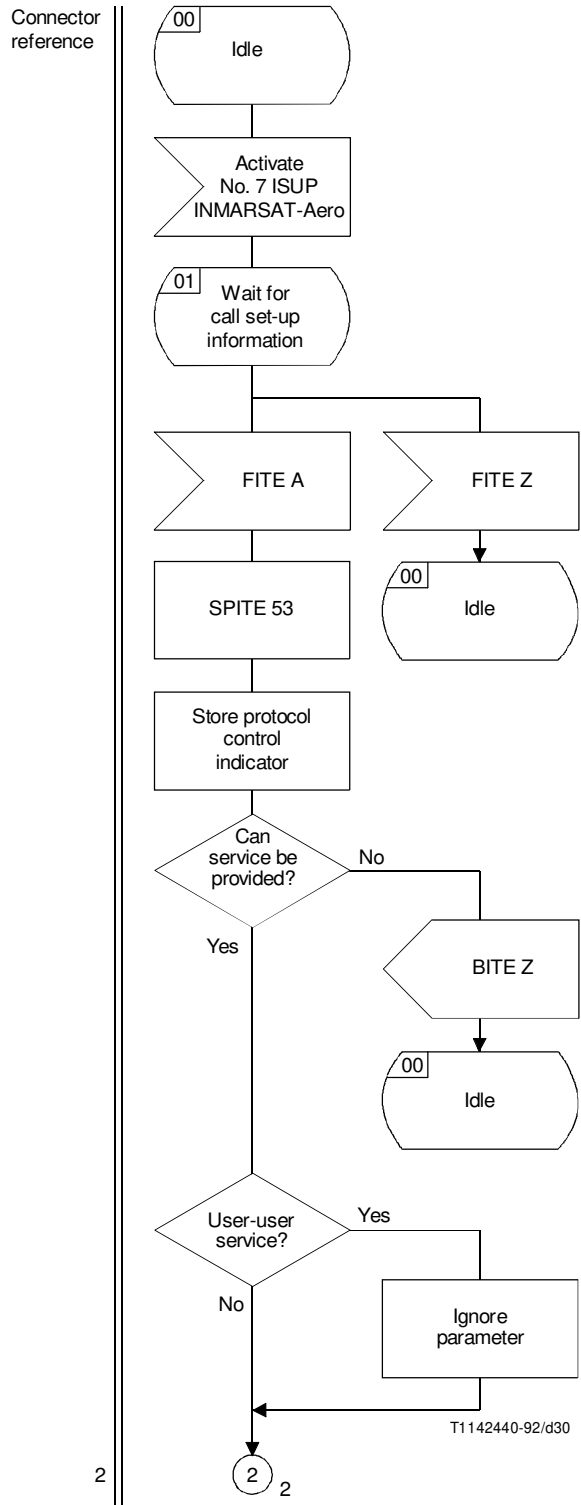
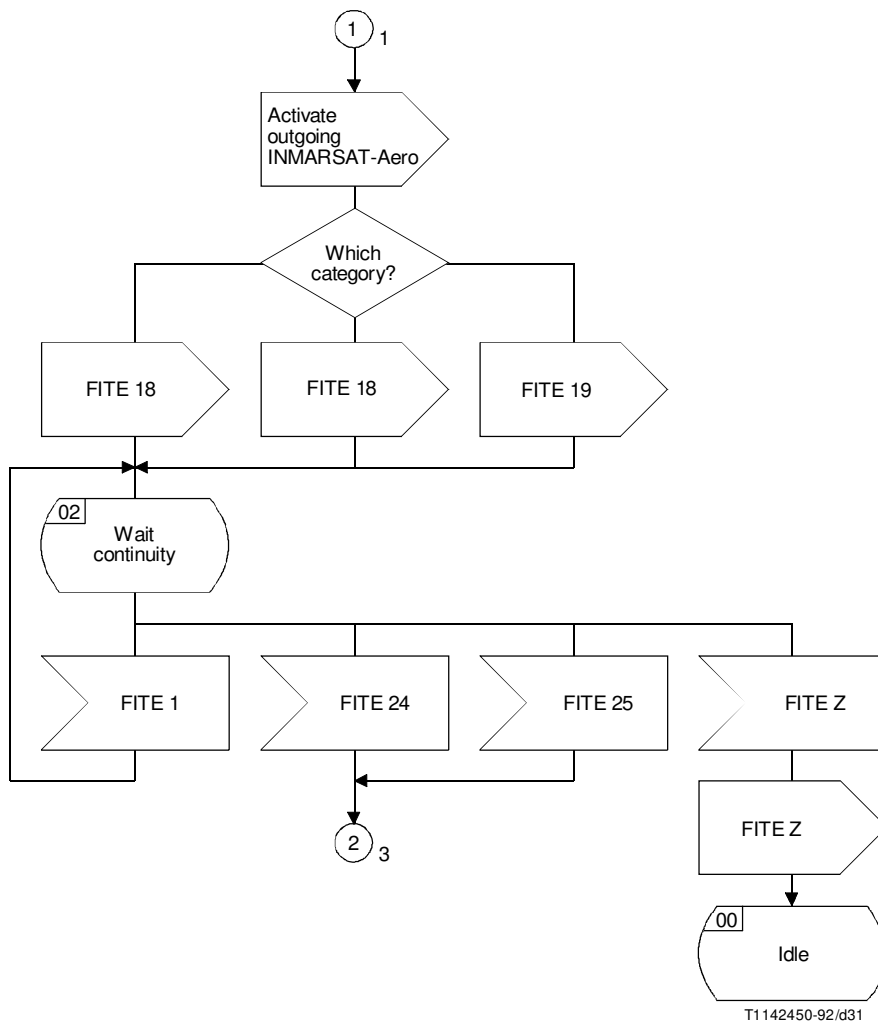

FIGURE 11/Q.1152 (sheet 1 of 4)
**Interworking of Signalling System No. 7 (ISUP)
 to INMARSAT-Aero**

Connector
reference

1



2

FIGURE 11/Q.1152 (sheet 2 of 4)
Interworking of Signalling System NO.7 (ISUP) to INMARSAT-Aero

Connector reference

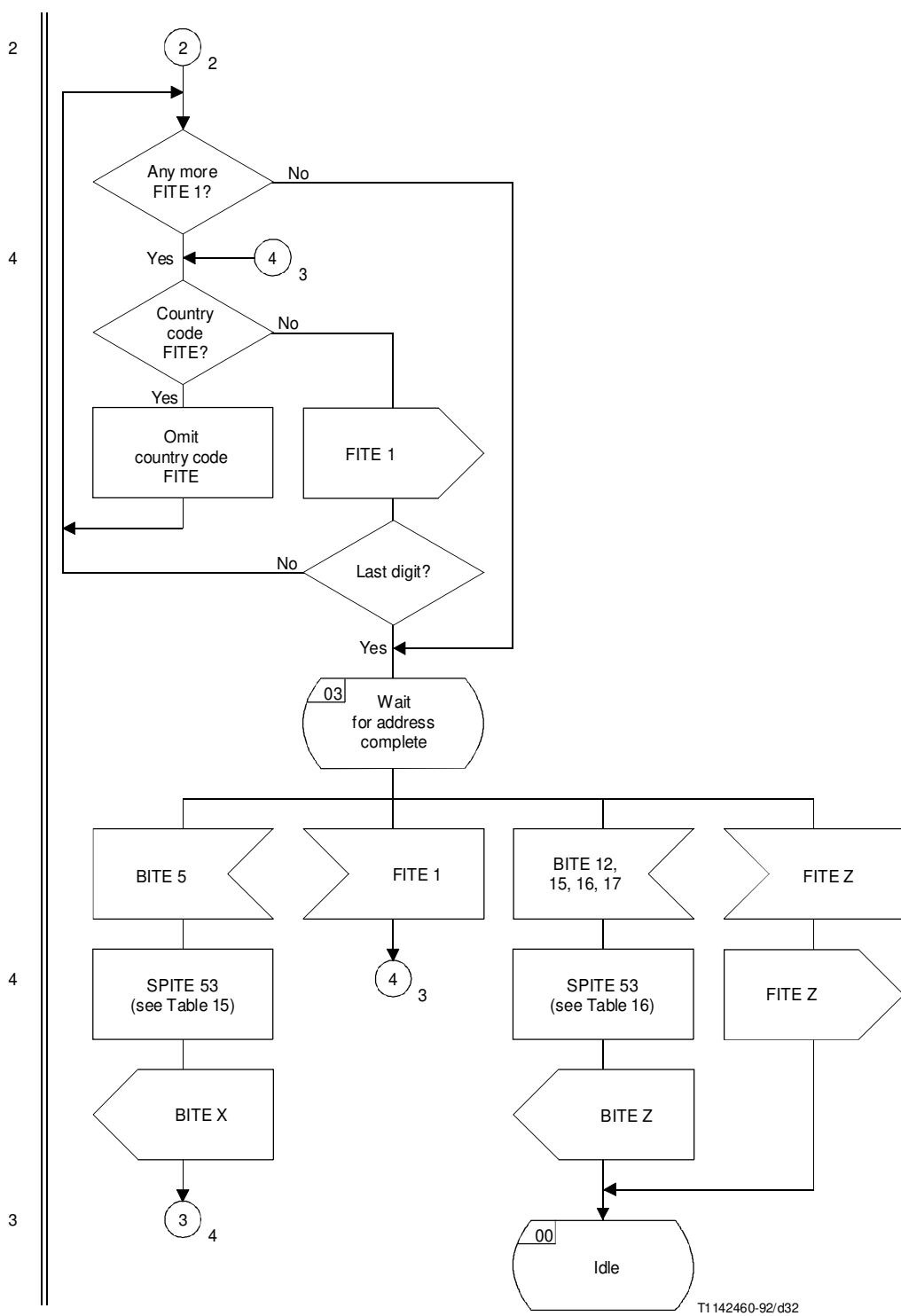

T1 142460-92/d32

FIGURE 11/Q.1152 (sheet 3 of 4)

Interworking of Signalling System No. 7 (ISUP) to INMARSAT-Aero

Connector
reference

3

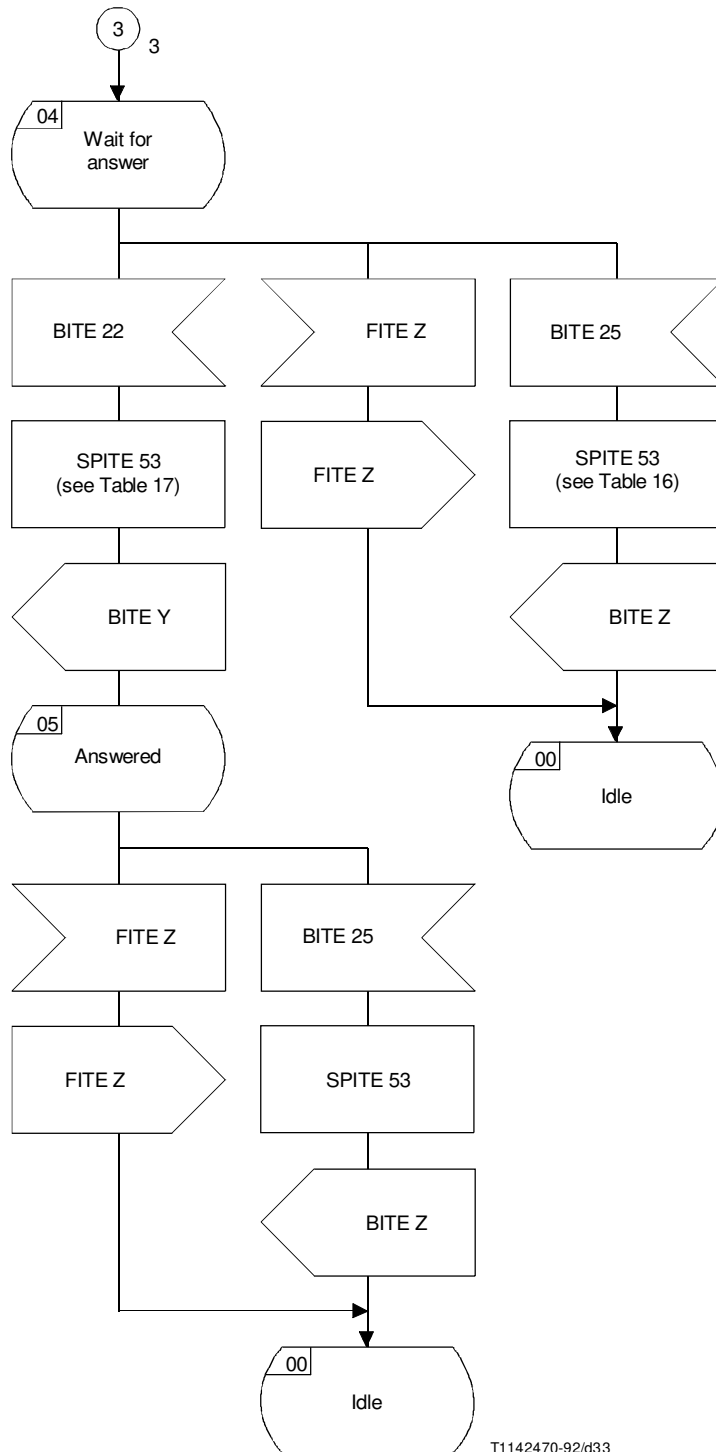
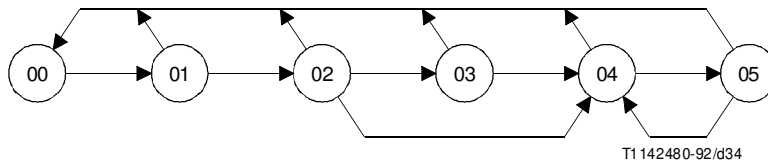

FIGURE 11/Q.1152 (sheet 4 of 4)
Interworking of Signalling System No. 7 (ISUP) to INMARSAT-Aero



State number	State description	Sheet reference
00	Idle	1
01	Wait for CPCI FITE	1
02	Await for address complete	2
03	Wait for answer	3
04	Answered	4
05	Clear back	4

FIGURE 12/Q.1152
**State overview diagram for interworking of INMARSAT-Aero
to Signalling System No. 7 ISUP**

Connector
reference

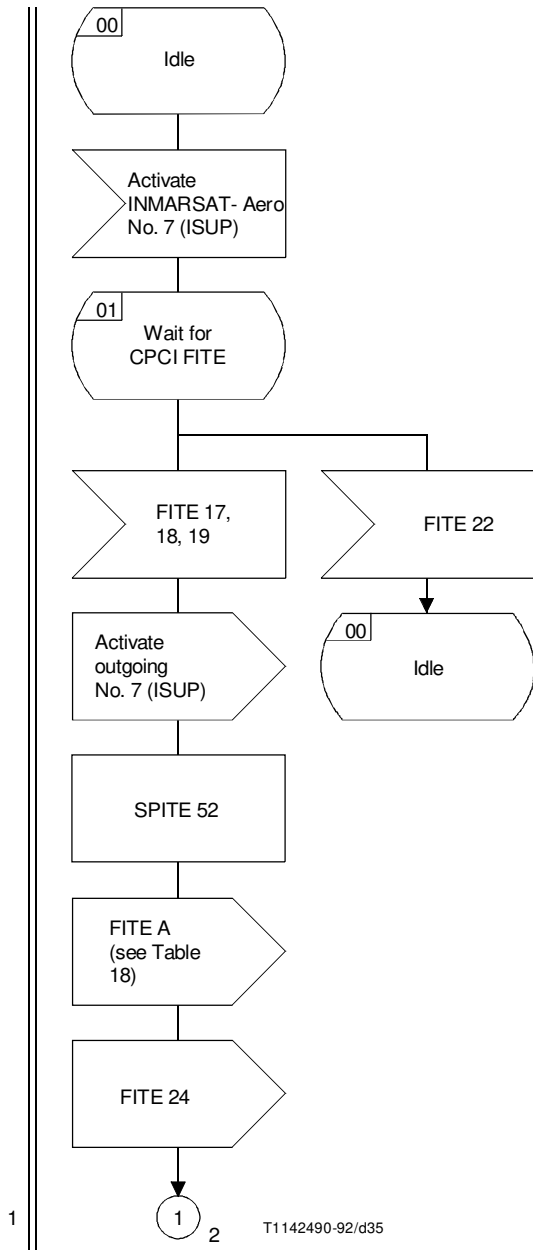

1

2

T1142490-92/d35

FIGURE 13/Q.1152 (sheet 1 of 5)

**Interworking of INMARSAT-Aero to
Signalling System No. 7 (ISUP)**

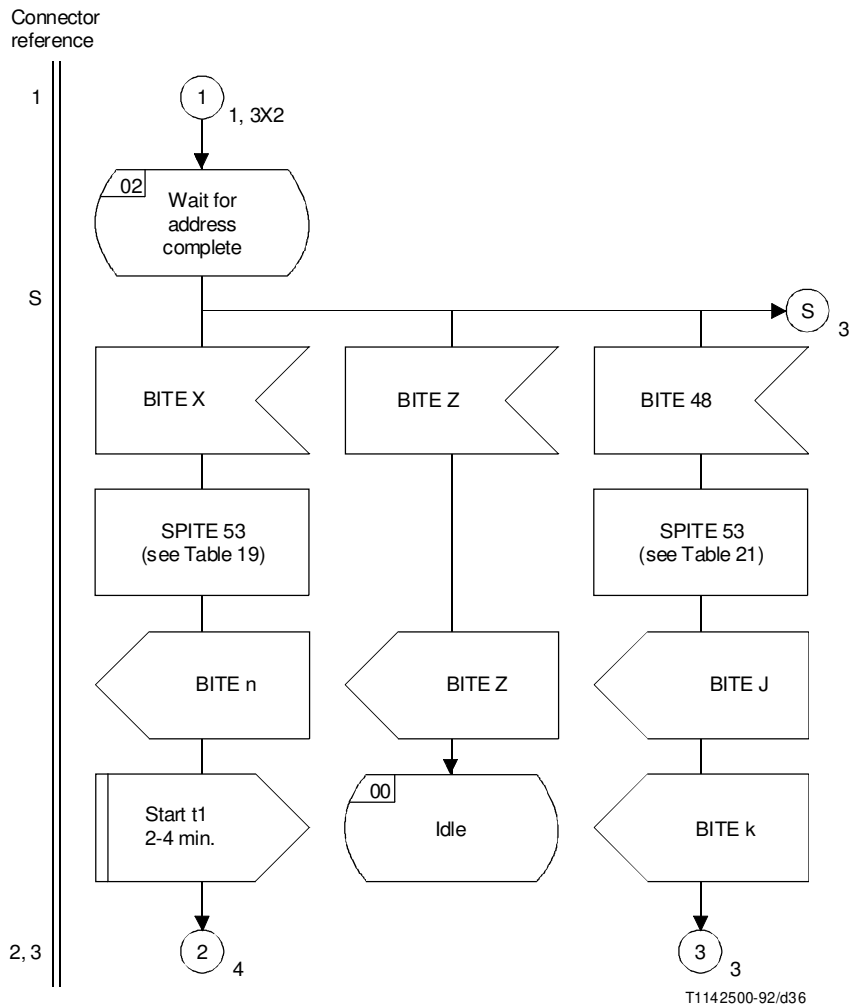
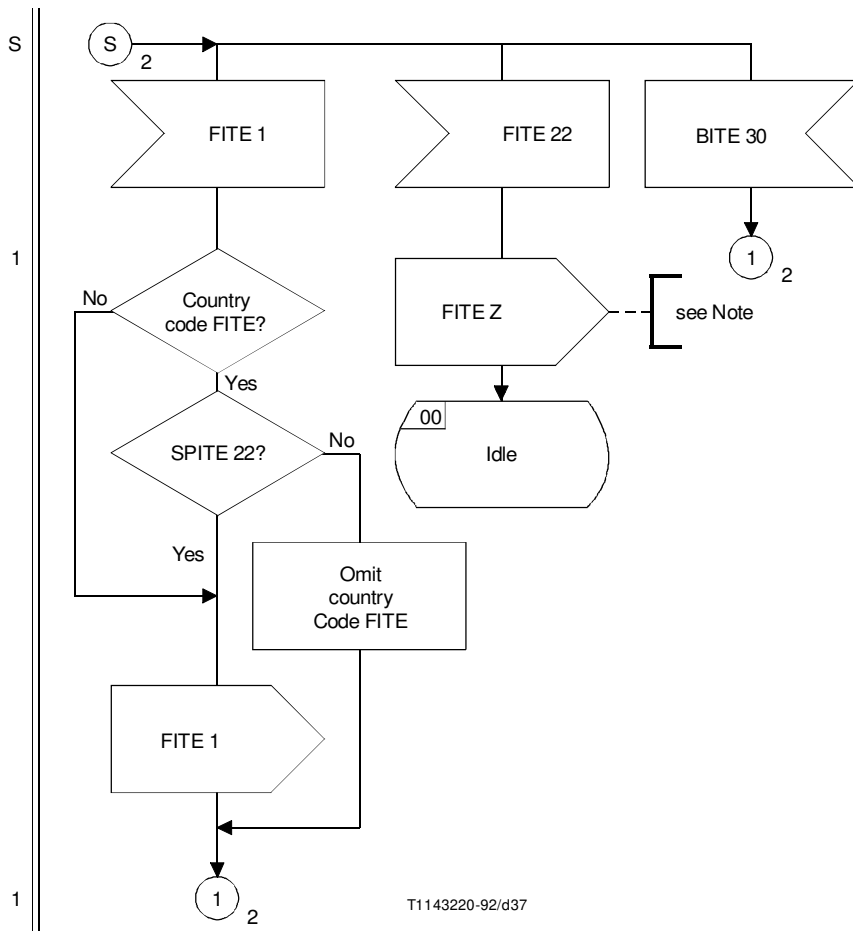

FIGURE 13/Q.1152 (sheet 2 of 5)
Interworking of INMARSAT-Aero to Signalling System No. 7 (ISUP)



NOTE – In principle, FITE 22 should result in cause 16. However, in the case where FITE 22 results from a time out expiry cause 127 should be sent.

FIGURE 13/Q.1152 (sheet 3 of 5)
Interworking of INMARSAT-Aero to Signalling System No. 7 (ISUP)

Connector reference

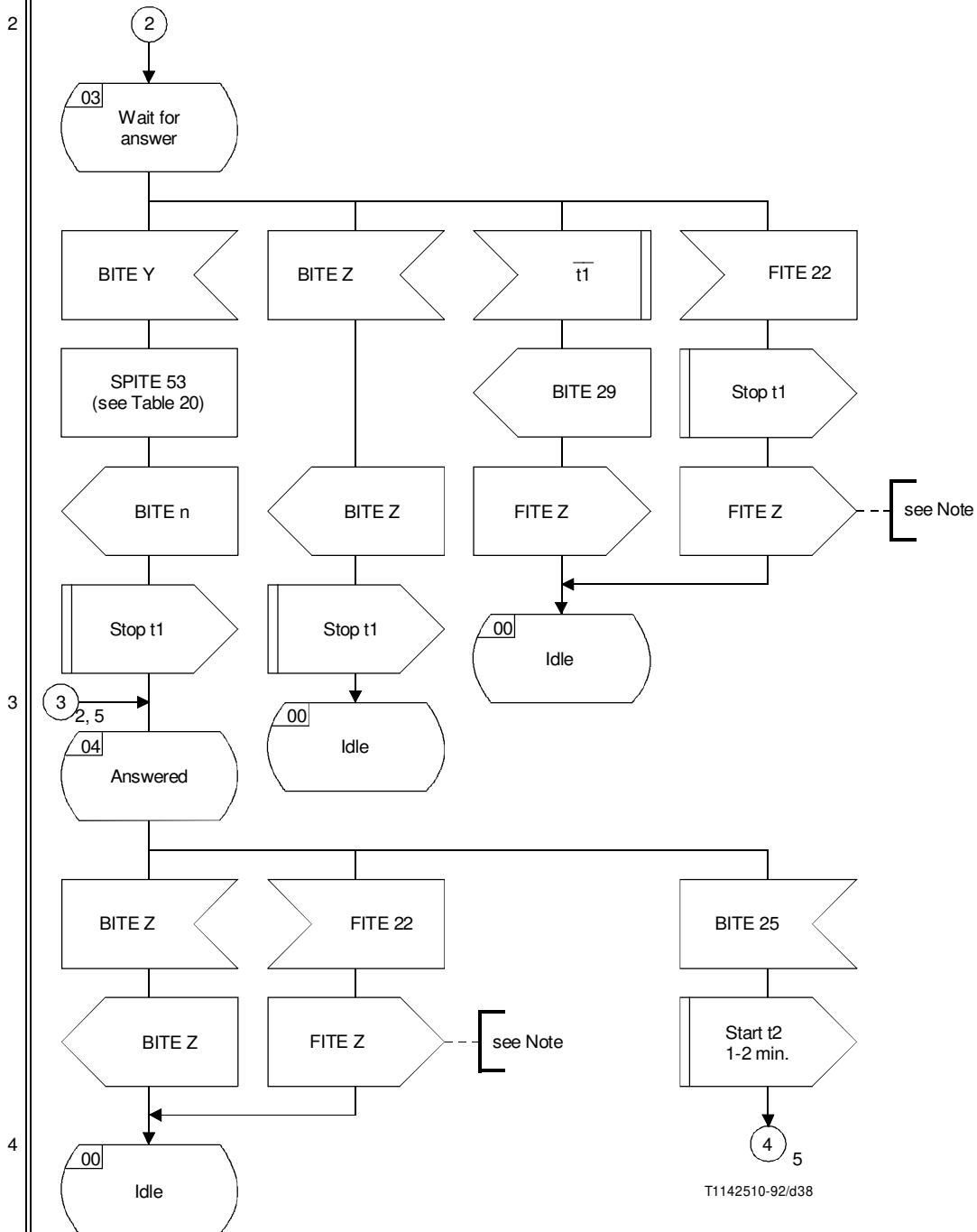

NOTE – In principle, FITE 22 should result in cause 16. However, in the case where FITE 22 results from a time out expiry cause 127 should be sent.

FIGURE 13/Q.1152 (sheet 4 of 5)

Interworking of INMARSAT-Aero to Signalling System No. 7 (ISUP)

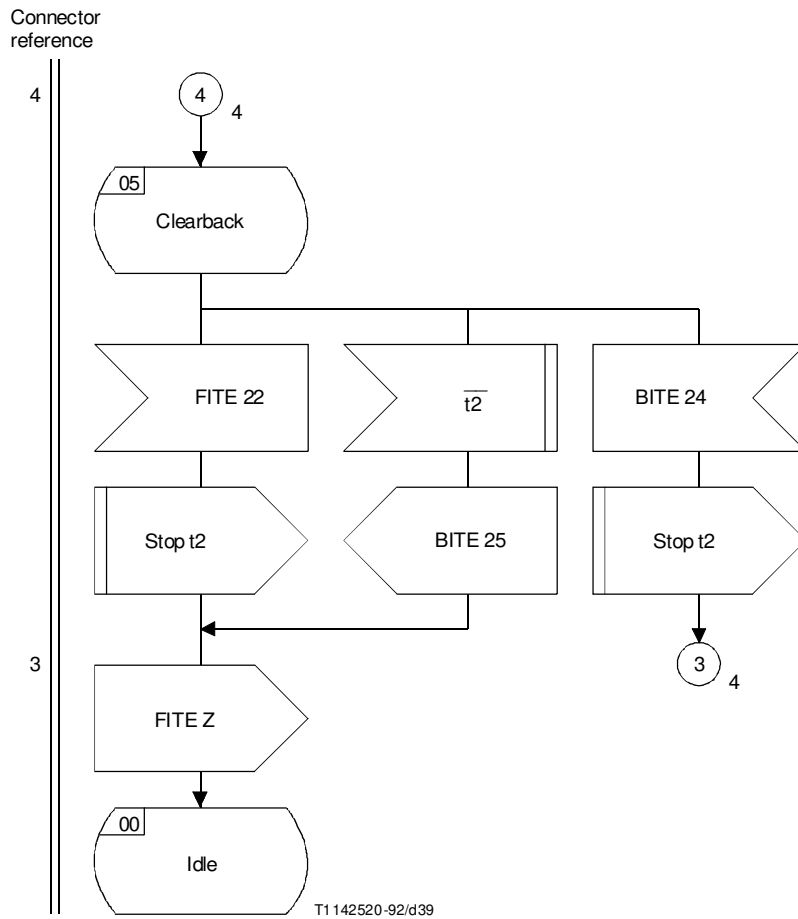

FIGURE 13/Q.1152 (sheet 5 of 5)
 Interworking of INMARSAT-Aero to Signalling System No. 7 (ISUP)

TABLE 15/Q.1152

	Received BITES
Backward call indicators in ACM	5
Charging indicator	10
Called party's status	01
Called party's category	00
Interworking indicator	1

TABLE 16/Q.1152

Received BITES (Release)	Cause sent	Location
12	34	1010
15	1	1010
16	17	1010
17	27	1010
25	16	1010

TABLE 17/Q.1152

Backward call indicators in ANM
ANM without backward call indicators is to be sent

TABLE 18/Q.1152

FITE A construction – Interworking of INMMARSAT-Aero to ISUP

Calling Party'S Category (CPC)	Received FITE	CPC
	17	1010
	18	1011
Continuity Check Indicator (CCH)	SPITE 36	CCH
	Yes	01
	No	00
Nature of Address Indicator (NAI)	SPITE 22	NAI
	Yes	100
	No	011
Satellite Indicator (SI)	SI = 1	
Echo Control Indicator (ECI)	SPITE 21	ECI
	Yes	1
	No	0
Transmission Medium Requirements (TMR)	Received FITE	TMR
	17	11
	18	11
	19	For further study
Closed user group interlock code	SPITE 51	
	Yes	–
	No	Set CUG interlock code

TABLE 19/Q.1152

Bite X analysis – Interworking of INMARSAT-Aero to ISUP

Received BITE X			BITE n to be sent
CH	ST	CAT	
00	00	00	BITE 27
00	00	01	BITE 27
00	00	10	BITE 27
00	01	00	BITE 5
00	01	01	BITE 5
00	01	10	BITE 7
01	00	00	BITE 27
01	00	01	BITE 27
01	00	10	BITE 27
01	01	00	BITE 6
01	01	01	BITE 6
01	01	10	BITE 7
10	00	00	BITE 27
10	00	01	BITE 27
10	00	10	BITE 27
10	01	00	BITE 5
10	01	01	BITE 5
10	01	10	BITE 7

CH	Charge indicator
ST	Called party's status indicator
CAT	Called party's category indicator

TABLE 20/Q.1152

Bite Y analysis – Interworking of INMARSAT-Aero to ISUP

Received BITE Y	BITE to be sent
CH	
–	BITE 22
00	BITE 22
01	BITE 23
10	BITE 22

CH	Charge indicator
----	------------------

TABLE 21/Q.1152

CONNECT analysis – Interworking of INMARSAT-Aero to ISUP

Received CONNECT fields			BITE j	BITE k
CH	ST	CAT		
00	00	00	BITE 27	BITE 22
00	00	01	BITE 27	BITE 22
00	00	10	BITE 27	BITE 22
00	01	00	BITE 5	BITE 22
00	01	01	BITE 5	BITE 22
00	01	10	BITE 7	BITE 22
01	00	00	BITE 27	BITE 23
01	00	01	BITE 27	BITE 23
01	00	10	BITE 27	BITE 23
01	01	00	BITE 6	BITE 23
01	01	01	BITE 6	BITE 23
01	01	10	BITE 7	BITE 23
10	00	00	BITE 27	BITE 22
10	00	01	BITE 27	BITE 22
10	00	10	BITE 27	BITE 22
10	01	00	BITE 5	BITE 22
10	01	01	BITE 5	BITE 22
10	01	10	BITE 7	BITE 22