



INTERNATIONAL TELECOMMUNICATION UNION

ITU-T

TELECOMMUNICATION
STANDARDIZATION SECTOR
OF ITU

Q.1151

(03/93)

**INTERWORKING WITH SATELLITE
MOBILE SYSTEMS**

**INTERFACES FOR INTERWORKING
BETWEEN THE INMARSAT AERONAUTICAL
MOBILE-SATELLITE SYSTEM AND
THE INTERNATIONAL PUBLIC SWITCHED
TELEPHONE NETWORK/ISDN**

ITU-T Recommendation Q.1151

(Previously "CCITT Recommendation")

FOREWORD

The ITU Telecommunication Standardization Sector (ITU-T) is a permanent organ of the International Telecommunication Union. The ITU-T is responsible for studying technical, operating and tariff questions and issuing Recommendations on them with a view to standardizing telecommunications on a worldwide basis.

The World Telecommunication Standardization Conference (WTSC), which meets every four years, established the topics for study by the ITU-T Study Groups which, in their turn, produce Recommendations on these topics.

ITU-T Recommendation Q.1151 was revised by the ITU-T Study Group XI (1988-1993) and was approved by the WTSC (Helsinki, March 1-12, 1993).

NOTES

1 As a consequence of a reform process within the International Telecommunication Union (ITU), the CCITT ceased to exist as of 28 February 1993. In its place, the ITU Telecommunication Standardization Sector (ITU-T) was created as of 1 March 1993. Similarly, in this reform process, the CCIR and the IFRB have been replaced by the Radiocommunication Sector.

In order not to delay publication of this Recommendation, no change has been made in the text to references containing the acronyms "CCITT, CCIR or IFRB" or their associated entities such as Plenary Assembly, Secretariat, etc. Future editions of this Recommendation will contain the proper terminology related to the new ITU structure.

2 In this Recommendation, the expression "Administration" is used for conciseness to indicate both a telecommunication administration and a recognized operating agency.

© ITU 1994

All rights reserved. No part of this publication may be reproduced or utilized in any form or by any means, electronic or mechanical, including photocopying and microfilm, without permission in writing from the ITU.

CONTENTS

	<i>Page</i>
1 General	1
2 Service capabilities.....	1
2.1 Channel capabilities.....	1
2.2 Bearer capabilities	2
2.3 Teleservices	2
3 Interworking scenarios	2
4 Connection interface requirements.....	4
4.1 General	4
4.2 MSSC-network interface	4
4.3 AES-MSSC interface.....	4
4.4 Calling procedures air-to-ground	4
4.5 Calling procedures, ground-to-air	5
5 Routing requirements.....	5
5.1 Ground originated calls.....	5
5.2 Aircraft originated calls	5
Appendix I – INMARSAT aeronautical mobile-satellite system description.....	5
I.1 Introduction	5
I.2 System evolution.....	7
I.3 Channel configuration	9
I.4 Link layer formats and protocols.....	10
I.5 Aircraft earth station management	11
I.6 Telephone services.....	11

INTERFACES FOR INTERWORKING BETWEEN THE INMARSAT AERONAUTICAL MOBILE-SATELLITE SYSTEM AND THE INTERNATIONAL PUBLIC SWITCHED TELEPHONE NETWORK/ISDN

(Melbourne 1988, modified at Helsinki, 1993)

1 General

1.1 This Recommendation provides information on the services offered in the INMARSAT aeronautical mobile-satellite system and describes the requirements for connection to and interworking with the public networks. Special terminology for this Recommendation is defined in Recommendation Q.1100. Detailed interworking procedures are set out in Recommendation Q.1152.

1.2 As well as connection to public networks, the aeronautical system is required to be able to interwork with existing specialized private networks. In implementing all interworking cases, regard should be paid to the open systems interconnection referenced model (X.200-Series Recommendations) and to ISDN services and signalling methods (I-Series Recommendations), with a view to achieving uniformity in user procedures and formats and to achieving generally applicable facilities.

1.3 Within the constraint of the need to operate as economically as possible, the preferred interworking cases are with the ISDN and with those parts of the international telephone network employing common channel signalling. If one of these is not available or accessible at the ISC to which an aeronautical ground earth station (GES) is connected then another signalling system from the Q-Series Recommendations should be used.

1.4 The use of the ISDN will offer both improvement in quality and more flexibility in service. It will be possible to supply either voice or data over the same network with the ability to change from one to the other under control of the aircraft earth station (AES) terminal.

2 Service capabilities

A general description of the INMARSAT aeronautical system is contained in Appendix I.

2.1 Channel capabilities

2.1.1 The system provides circuit-mode single channel per carrier (SCPC) channels at a range of information bit rates, including at least the following:

9600 bit/s; 4800 bit/s; 2400 bit/s

Channels for other information bit rates, such as 64 000 bit/s, may be defined in the future.

2.1.2 The system provides demand assigned forward (ground to air) TDM channels and return (air to ground) random access and (reservation) TDMA channels, at a range of bit rates. Although the following bit rates include housekeeping overheads, they are indicative of the information bit rates provided:

300 bit/s; 600 bit/s; 1200 bit/s; 2400 bit/s; 5250 bit/s.

Channels for other bit rates may be defined in the future.

2.2 Bearer capabilities

2.2.1 The following bearer services on SCPC channels, with the following information transfer attributes as defined in Recommendation I.211, may be supported:

- a) speech (initially at 9.6 kbit/s); transcoding to 64 kbit/s PCM should take place at the GES;
- b) circuit mode audio service (initially at 9.6 kbit/s), suitable for voice and other signals occupying the same bandwidth; transcoding to 64 kbit/s PCM should take place at the GES;
- c) virtual call bearer service at any of the bit rates defined in 2.1.1, with rate adaptation in the GES to 64 kbit/s using, for example, flow control and flag stuffing;
- d) digital data, circuit mode interworking with the ISDN should take place as defined in Recommendation X.30 for data terminals designed to Recommendation X.21, and Recommendation X.32 for data terminals designed to Recommendation X.25.

2.2.2 The following bearer services on TDM, TDMA and RA channels may be supported:

- a) virtual call bearer service – interworking with the ISDN should take place as defined for interworking between PSPDNs and the ISDN.

2.3 Teleservices

Teleservices, when supported, should be in accordance with Recommendation I.212. It is to be observed that not all teleservices of ISDN may be supported with bearer services that can be provided on SCPC or TDM/TDMA channels operating at the available information bit rates.

3 Interworking scenarios

Three interworking scenarios can be envisaged for the interface between the MSSC and the fixed networks.

3.1 The first scenario is shown in Figure 1. The MSSC public network interface is to the PSTN only, with all data services, and some voice services, handled via private networks.

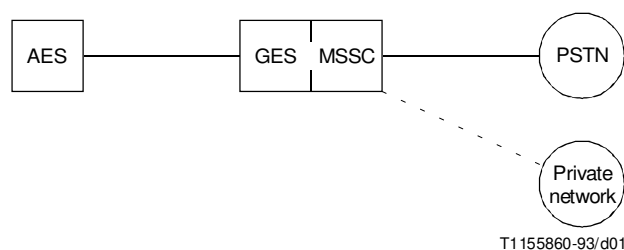

FIGURE 1/Q.1151
Interworking scenario with PSTN interface

3.2 Figure 2 shows the situation where an ISDN exists and the MSSC has an interface to it. Interworking with the PSTN is achieved via the ISDN. Interworking with PDNs may be by direct interface with the PDN or via the ISDN, as in the case of the PSTN.

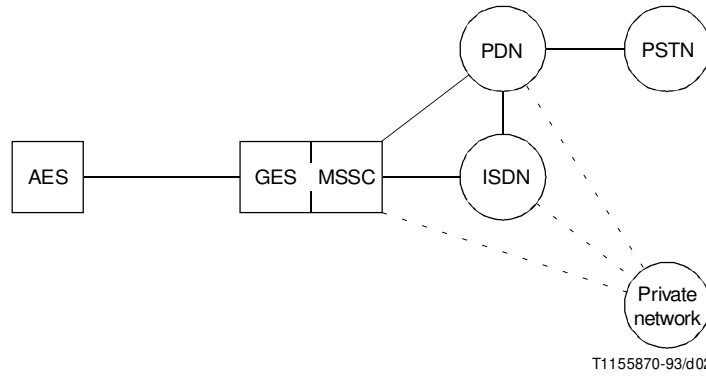

FIGURE 2/Q.1151
**Interim interworking scenario with interfaces
to ISDN and other fixed networks**

In this scenario interworking with the ISDN supports speech, 3.1 kHz audio and data services as indicated in 2.2.1. Other bearer services as indicated in 2.2.2 may require interworking with PDNs.

3.3 The third scenario is shown in Figure 3. The MSSC interfaces to the ISDN, which provide data services as well as voice, although some voice and data services may still use private networks.

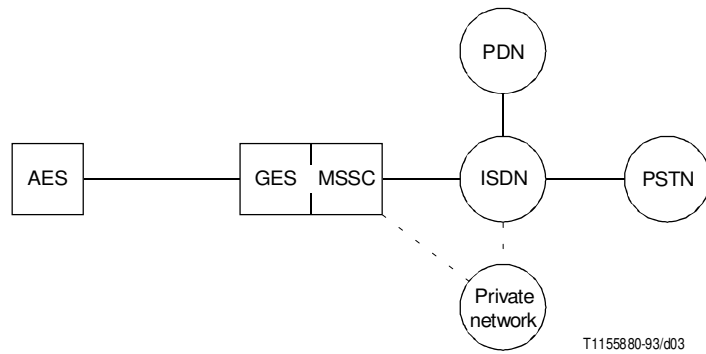

FIGURE 3/Q.1151
Interworking scenario with ISDN interface only

4 Connection interface requirements

4.1 General

This subclause identifies the information that must be available at the interfaces between the AES and the MSSC and between the MSSC and the fixed network, principally for the connection of services identified in 3.

4.2 MSSC-network interface

For ISDN connections ISUP should be used for message transfer. For non-ISDN or where ISUP is not available, TUP would be preferred.

If information transport between MSSCs over the fixed network is required, it is suggested that the procedures of the SCCP is used. Detailed interworking procedures are defined in Recommendation Q.1152.

4.3 AES-MSSC interface

Prior to and during call initiation the signalling channel functions may be provided by one or more common control channels.

A signalling capability should always be available during conversation in case it is needed for call clearing, call control, or for call management purposes. During a call the signalling channel may be multiplexed with the traffic channel at a lower bit rate so as to conserve radio channel capacity.

The multiplexed signalling channel or TDM/TDMA/RA channels may be used for bearer services such as connectionless data services, or connection oriented data services not requiring the establishment of a traffic channel.

The traffic channel should be used for bearer services such as:

- speech;
- circuit mode data services;
- packet mode data services;
- voice band data services.

4.4 Calling procedures air-to-ground

4.4.1 Passenger telephony operation

- a) The equipment for passenger telephony may consist of the following:
 - the AES;
 - cabin telephone equipment consisting of a fixed piece of equipment and a handset, which may be “cordless”.

The fixed cabin telephone equipment should be provided with a credit card reader.

- b) When a passenger wants to make a call, the typical sequence of events would be as follows:
 - i) key-in seat number;
 - ii) when this is accepted, insert credit card; and
 - iii) when this is accepted, remove handset and return to seat.
- c) At the cabin telephone location, if a credit card which corresponds to the recognized card format is inserted into the equipment, the handset shall be released after validation of the check bits and expiry date. In the event that either of these checks fail, the card shall be returned and the handset not released. Upon obtaining the handset the customer returns to his seat and can commence making one or more telephone calls.
- d) Where telephones and associated credit card readers are located at the passengers' seats, a somewhat different procedure may apply. However, the procedure will still involve reading the credit card, validating the check bits and checking expiry date, before making calls.

4.4.2 Crew telephony operation

For this case, credit card validation procedures are not required. Crew will have access to special telephone services and networks, according to requirements and procedures developed by the industry. The capabilities will include at least the following:

- a) access to the full public telephone network as for passengers, but without the need for a credit card (billing would be direct to the aircraft operator);
- b) access to specialized voice services via private networks, with or without address digits;
- c) ability to preempt an existing (passenger) call if necessary to make AES voice circuit equipment, a satellite channel or GES voice circuit equipment available;
- d) ability to seize the next available AES voice circuit equipment, but without clearing any calls in progress.

4.5 Calling procedures, ground-to-air

4.5.1 Selected fixed network users should be able to access aircraft automatically by using the aircraft ID in the address digits. Operator connected access may also be available.

4.5.2 The numbering plan to enable a PSTN subscriber to call the AES is defined in Recommendation E.215.

5 Routing requirements

5.1 Ground originated calls

The country code 87S should be analysed at all transit centres where the call may either be routed on a circuit containing a satellite link or on a circuit not containing a satellite link. The latter circuit should always be chosen (see Recommendation Q.14).

5.2 Aircraft originated calls

If the signalling system provided between the MSSC and the terrestrial network contains signals which may be used to indicate that one satellite link is included, such signals should be used.

If the signalling system does not contain such signals, the outgoing ISC should avoid forwarding the call on an outgoing circuit which includes a satellite link. If, however, the signalling system employed between the outgoing ISC and the next ISC in the connection contains such signals, the outgoing ISC should insert the required information. The outgoing ISC could base its procedure upon incoming route identification.

Appendix I

INMARSAT aeronautical mobile-satellite system description

(This appendix does not form an integral part of this Recommendation)

I.1 Introduction

The aeronautical satellite system is a mobile communications system intended for use by aircraft in flight. It can provide voice communication services and a range of data communications services.

I.1.1 The major elements of the aeronautical satellite system as described in this appendix are as follows (see also Figure I.1):

- a) space segment, in particular the satellite communication transponders and associated frequency bands assigned for use by the aeronautical satellite system;
- b) aircraft earth stations (AES) which are in accordance with the relevant technical requirements, and which interface with the space segment at L-band for communications with ground earth stations, and which interface in the aircraft with data equipment and with crew and passenger voice equipment;
- c) aeronautical (ground) earth stations (GES) which interface with the space segment (at C-band and L-band) and with the fixed networks, and which are operated in accordance with the relevant technical and operational requirements for communications with AESs; for the "Initial System" GESs will operate to their own essentially independent networks; and
- d) network coordination stations (NCS) located at designated earth stations, for the purpose of allocating satellite channels, and also for system control and monitoring; NCSs are planned to be introduced at a later stage as part of the "Enhanced System".

I.1.2 The aeronautical system is made up of independent communication networks for each satellite ocean area, each network comprising the operational satellite and associated ground control facilities, the AESs and GESs operating within that area, and an NCS. The system design permits GESs to establish communications on a stand-alone basis with AESs without the intervention of the NCS, except in cases of satellite channel shortage.

I.1.3 Each AES is equipped with a capability to receive a medium rate forward channel transmitted from a GES with a transmission rate of 600 bit/s carrying signalling and data messages in packet form.

I.1.4 Each AES is equipped to transmit a return carrier in burst mode at a transmission rate of either 600 bit/s or 1200 bit/s controlled by signalling messages received via the forward 600 bit/s channel. This dual capability is required to enable some advantage of the variations in aircraft antenna pattern and in spacecraft receiver sensitivity, which will be encountered during a flight, to be taken.

I.1.5 AESs may also be equipped with pairs of transmit/receive voice channel equipment and data channel equipment for higher bit rates.

I.1.6 Each GES is equipped with at least the following data-only transmission capabilities:

- a) one 600 bit/s transmitter for the forward channel;
- b) four 600 bit/s receivers for the slotted random access channels (this is the minimum to be provided for diversity protection against interference, and burst re-collisions); and
- c) a receiver for its 600 bit/s forward channel and for the forward channels of each other GES working to the same satellite.

I.1.7 At the GES owner's option, GESs may also be equipped with:

- a) pairs of transmit/receive voice channel equipment;
- b) 600 bit/s receiver(s) for a Reservation TDMA channel(s), or 600 bit/s and 1200 bit/s receiver(s) for Reservation TDMA channel(s); and
- c) additional data channel equipment for the same or higher bit rates.

I.1.8 The system provides for voice communications by means of the voice channels. Signalling and user data communications is carried on the medium rate (600/1200 bit/s) data channels. This signalling and user data is formatted into fixed length signal units of either 96 bits (12 octets) or 152 bits (19 octets), which are combined as necessary to support various message sizes according to user requirements.

I.2 System evolution

I.2.1 General

I.2.1.1 The capabilities of the system will evolve with time, due to the progressive development of each of the four major elements identified in I.1.1 above, i.e. space segment, AES, GES and NCS. Although some of the evolutionary steps of one element are inevitably linked with those of other elements, in general the system concept is to allow the individual elements to evolve independently. The pressures which are expected to lead to this evolution include traffic growth, market awareness, new applications and new technology.

I.2.1.2 The use of narrow-band channels (generally single channel per carrier) and software programmable channel units (modems, etc.) are the principal requirements to achieve the required flexibility, to efficiently utilize a variety of satellite parameters, take advantage of future advances in voice coding technology, allow the aircraft installation to match the services required, and provide a smooth growth path from an initial start-up system through increasing levels of traffic.

I.2.2 Space segment evolution

I.2.2.1 Within the aeronautical system operational timeframe, it is anticipated that the satellite types of INMARSAT's first generation space segment still in service will comprise MARECS (leased from the European Space Agency) and INTELSAT-V MCS satellites (Maritime Communications Sub-System, leased from the International Telecommunications Satellite Organization). Satellite tracking, telecommand, telemetry and ranging services are included in the leasing arrangements with ESA and INTELSAT, with TT&C stations linked to satellite control centres (SCCs) at Darmstadt (Germany) and Washington DC, respectively. The SCCs are in turn linked to the INMARSAT Operations Control Centre (OCC) in London.

I.2.2.2 The aeronautical system will also operate with and take advantage of the improved performance of the (second generation) INMARSAT-2 satellites, now on order.

I.2.3 AES evolution

I.2.3.1 Two types of aircraft antenna are defined, one with a minimum gain of 0 dBi over its coverage area, the other with a minimum gain of 12 dBi over its coverage area. In the initial system, AESs with the 0 dBi antenna are limited to medium rate data services (see I.2.4.2), while AESs with the 12 dBi antenna can obtain multi-channel voice service as well as data services at higher bit rates.

I.2.3.2 Irrespective of the antenna gain, each AES is required to be equipped with a bit rate switchable data channel unit. The minimum capability is to provide for both 600 bit/s and 1200 bit/s transmission rates (300 bit/s and 600 bit/s information rate, less overheads) and this will suffice for the initial two or three years. Additional, higher bit rates will be needed in the future and these could be provided for in the initial AES design, or be achieved by a software upgrade in a programmable channel unit, or by replacement of a plug-in card.

I.2.3.3 In operation, the bit rate in use by the AES for data services is determined by signalling from the ground. When commencing service with a given GES, an AES goes through a "log-on" procedure, using the 600 bit/s transmission rate channels assigned for system management (and possibly other) functions. In this log-on procedure, the AES gives its class of equipment provision, and the GES measures the signal level received from the AES if needed, to determine whether a higher bit rate could be supported. From this information the GES assigns working channels for further signalling and data transactions with the AES.

I.2.3.4 Since the other elements of the system will evolve with time, the AES capabilities have been defined in a way which provides adequate service levels in the start-up phases, but which can take advantage of improved performance in the other elements as they become available, without requiring any significant replacement or upgrade of components. Specifically, the AES is specified with a linear high power amplifier (HPA) with a power output of 40 Watts, and a family of digital channels is defined which are all mutually consistent and compatible.

This makes it feasible to use a single programmable channel unit [using digital signal processor (DSP) microprocessor chips] to implement a suitable selection of channel types from the family, and allow for additional or alternative channel types in the future if required, by software upgrade. The linear characteristic of the HPA permits matching the evolution

of space segment characteristics, providing progressively greater numbers of voice channels with higher performance spacecraft, and also allowing the separation of services in different GESs if required in the future [such as dedicated GESs for air traffic services (ATS)].

I.2.3.5 It may be anticipated that the service requirements and technology applied to them on aircraft will develop independently of satellite communications. Examples of this type of development are data applications such as for monitoring of equipment health, and the progressive reduction of digital bit rate needed to provide voice service of a given quality. This system makes specific provision for evolution in voice coding, and by adopting a layered approach, along the lines defined in the Open System Interconnection (OSI) model, facilitates its use for as yet unforeseen data applications. In addition, there is ample provision of spare codes in the critical signalling fields, so that if enhancements become necessary they can be implemented by software upgrades.

I.2.3.6 Although the AES is specified to use a linear HPA, the offset QPSK modulation method is used in the higher bit rate channels in order to make operation with a hard limiting linear (e.g. Class C) HPA feasible. This will permit the development of single-channel AES equipment suitable for general aviation aircraft, when a demand develops.

I.2.4 GES evolution

I.2.4.1 The aeronautical GES has been defined so it can be produced as a compatible add-on to an existing standard coast earth station in the INMARSAT system. While this type of sharing is not essential, it may enable some economies to be achieved particularly in the start-up phase of the system, and where both services are carried by the same satellite.

I.2.4.2 As new satellites become available and traffic grows, the data transmission bit rates which can be supported, and need to be supported, will increase. To achieve this, additional data channel units, and/or higher bit rate channel units, will need to be provided at the GESs. The system can operate exclusively with data channel bit rates of 600 bit/s, and this may be sufficient in the initial stage. However, higher bit rates in the return direction (air-to-ground) can be supported even from a 0 dBi antenna, except at edge of coverage with existing (first generation) spacecraft, and will be able to be supported globally with INMARSAT-2 satellites. Thus the provision of higher bit rate channel units by the late 1980s will be appropriate, to provide for growing traffic and to minimize data service message delays. Depending on demand, it may also be appropriate to provide data channel units for interworking with aircraft fitted with 12 dBi antennas. Since all the channels form a compatible family, the possibility exists of using a common hardware unit for all these channels, differing only in software.

I.2.4.3 To take advantage of evolution in voice coding technology, it may be anticipated that a point will be reached when the voice coding rate and algorithm used in the initial system will be considered inappropriate, at least for new aircraft installations. A decision to adopt new voice coding rate will be practicable, the main requirement being that GESs wishing to interwork with all aircraft will need to operate two sets of channel units and associated voice codecs. As for data, the channel unit hardware could be common, although the voice codecs may be of different designs.

I.2.5 NCS evolution

I.2.5.1 The function of the NCS is to manage a common pool of satellite voice channels, and to assign them on demand to individual GESs for the duration of one call. In a system with small capacity and multiple GESs the random distribution of traffic across GESs necessitates the provision of a common pool managed by an NCS, for efficiency reasons. When traffic is low in the initial start-up phase, operation with only individual pools of channels at each GES will be satisfactory, but as additional GESs come into service the NCS will become essential.

I.2.5.2 In the initial system operating without an NCS, communication between GESs is still required to allow aircraft to call or be called via more than one GES. This communication is achieved by using a forward channel from each GES; the channel could be the one also designated for system management functions, or a separate, lower powered channel. In any case the implementation should be arranged so as to facilitate a changeover to a separate interstation link and the provision of an NCS, in the long term.

I.3 Channel configuration

I.3.1 General

I.3.1.1 The basic transmission characteristics of the family of aeronautical system channels are given in Table I.1. The channel bit rates have been selected to facilitate their implementation using a single programmable channel unit and to provide future flexibility. While this may not be practicable now for the highest bit rates in the table, future implementations may be able to take advantage of this structure.

TABLE I.1/Q.1151
Channel transmission characteristics summary

Bearer rate (bit/s)	Channel rate (bit/s)	Channel spacing (kHz)	Modulation
9600	21 000	17.5	O-QPSK
9600	10 500	10.0	O-QPSK
5250 ^{a)}	10 500	10.0	O-QPSK
4800	5 250	5.0	O-QPSK
2400	6 000	5.0	O-QPSK
2400 ^{a)}	4 800	5.0	O-QPSK
1200 ^{a)}	2 400	5.0	DECPSK
600 ^{a)}	1 200	5.0	DECPSK
300 ^{a)}	600	5.0	DECPSK

a) Less overheads.

I.3.2 Channel naming

In order to simplify references to the various channel formats included in the system, each individual format has been assigned a designation as follows (see also Figure I.1):

a) *P-Channel*

Packet mode time division multiplex (TDM) channel, used in the forward direction (ground-to-air) to carry signalling and user data; the transmission is continuous from one GES; a P-channel being used for system management functions is designated Psmc, while a P-channel being used for other functions is designated Pd;

b) *R-Channel*

Random access (slotted ALOHA) channel, used in the return direction (aircraft-to-ground) to carry some signalling and user data, specifically the initial signals of a transaction, typically request signals; an R-channel being used for system management functions is designated Rsmc, while an R-channel being used for other functions is designated Rd;

c) *T-Channel*

Reservation Time Division Multiple Access channel, used in the return direction only; the receiving GES reserves time slots for transmissions requested by AESs, according to message lengths and priority;

d) *C-Channel*

Circuit-mode single channel per carrier (SCPC) voice/data channel, used in both forward and return directions; the use of the channel is controlled by assignment and release signalling at the start and end of each call.

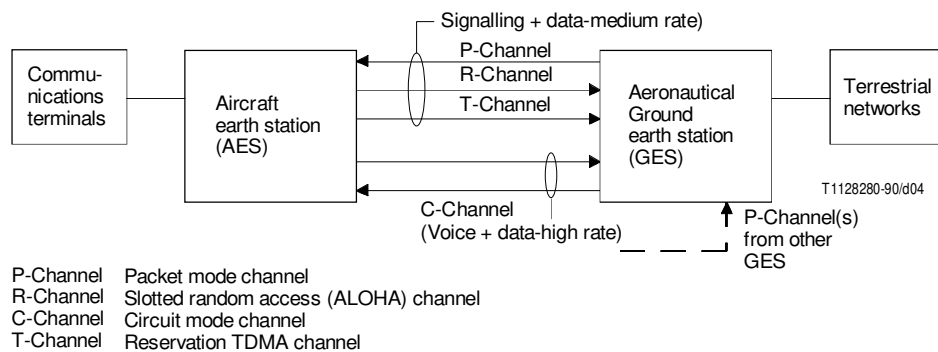

FIGURE I.1/Q.1151
Aeronautical network configuration

I.3.3 Forward error correction coding

The majority of channel types use Forward Error Correction (FEC) coding consisting of a convolutional encoder of constraint length $k = 7$ and an 8-level soft decision Viterbi decoder; the FEC coding rate is either $3/4$ or $1/2$; the rate $3/4$ code is derived by puncturing the rate $1/2$, $k = 7$ convolutional code.

I.4 Link layer formats and protocols

I.4.1 General

All signalling and user data messages are formatted into signal units of length either 96 bits (12 octets) or 152 bits (19 octets). The extended length signal units (19 octets) are only used on the R-channel, whereas the standard length signal units (12 octets) are used on all channels.

More complex messages (including user data) can be carried by a sequence of several signal units. Longer messages generated in a user application will be broken into message fragments in the network layer, compatible with the maximum size, before being presented for transmission via the link layer; the use of these signal units applies to signalling and user data transactions on the sub-band channel of the voice/data channel as well as the P-, R- and T-channels.

I.4.2 Basic signal unit concepts

I.4.2.1 A message that can be accommodated in a single signal unit is formatted into a "Lone Signal Unit" (LSU). Longer messages are formatted into more than one signal unit, of which the first is an "Initial Signal Unit" (ISU) followed by one or more "Subsequent Signal Units" (SSU).

I.4.2.2 Each signal unit includes 16 check bits (the last two octets) for error detection, these being calculated from the preceding octets of the signal unit using the polynomial: $x^{16} + x^{12} + x^5 + 1$ for generation (see 2.2.7/X.25). The undetected error rate on the sub-band C-channel, under nominal worst case conditions is typically less than one in 10^{10} signal units. The undetected error rate on P- and R-channels is expected to be much less than this.

I.4.2.3 At the receiver for any channel, the check bits for each received signal unit are calculated, and if there is a mismatch with the received check bits the signal unit is discarded. Recovery from lost and corrupted signal units is handled either by a Reliable Link Service function, or by the relevant signalling logic procedures.

I.5 Aircraft earth station management

I.5.1 Every GES maintains an up-to-date status table of AESs which have logged into the GES, and has an inter-GES and GES-NCS signalling facility, so that every GES shall be able to set up calls to and from any AES operating to the same satellite, and to manage AESs in the handover process.

I.5.2 Every AES logs-on to a GES of its choice for entering into the Aeronautical system and logs-out as part of terminating its operation in the system. When an AES requires a change in its log-in GES, accessing satellite or accessing spot beam of a satellite, the AES follows a handover procedure resulting in a smooth transition.

I.6 Telephone services

I.6.1 General

I.6.1.1 Telephone services are provided using a pair of C-channels (one in each direction) assigned from a pool held by the GES, or by the NCS from a common pool. The function of the NCS is to make C-channel assignments in response to requests from GESs (when the latter runs out of frequencies) on a call-by-call basis.

I.6.1.2 In the ground-to-air direction, all telephone calls may go to a single answering point on the aircraft, or may be addressed to specific answering points. In the initial system at least, for commercial aircraft, access will be restricted to a very limited number of callers for operational and practical reasons. This restriction will be imposed in the GES, or elsewhere, at the discretion of the GES owner.

I.6.1.3 In the air-to-ground direction, calls may be made by crew or passengers, with several types of service provided. The primary service capabilities include:

- a) passenger telephony;
- b) crew general telephony; and
- c) crew ATC voice.

I.6.2 Call set-up/termination for air-to-ground calls

I.6.2.1 The basic sequences for air-to-ground telephone call set-up are shown in Figures I.2 to I.5, covering various cases including use of an NCS.

I.6.2.2 From the point of view of the AES, all the cases are the same, with the AES receiving the called number (and in the case of passenger calls the credit card data) prior to starting the request process. An initial request is sent using the R-channel to the GES where the AES is logged in, and a channel assignment is received on the corresponding P-channel. The communications channel is then set up, tested using signals on the sub-band data channel, and the called party address (plus the credit card number if applicable) is transmitted via the sub-band data channel.

I.6.2.3 If the air-to-ground call is to the log-on GES (Figure I.2), then all the access request and channel assignment transactions are carried via the R- and P-channels only. However, if the call is to a GES other than the one where the AES logged-on (Figure I.3), then the log-on GES forwards the access request (from the AES) to the called GES (designated "other" GES in Figure I.3) over the interstation link. The called GES allots a channel, if available, from its pool and transmits the channel assignment information over the interstation link. The log-on GES then forwards the information to the AES over the P-channel. The corresponding signalling sequences for air-to-ground call set-up using the NCS are shown in Figures I.4 and I.5, the former representing the case of a call addressed to a log-on GES and the latter showing a call addressed to a GES other than the one where the AES has logged-on.

In the former case (Figure I.4), the log-on GES, on receipt of an access request from the AES, sends a Request for Assignment message over the interstation link to the NCS, whereupon the NCS responds by sending a channel assignment to the requesting GES over the same interstation link. The GES sends this channel assignment to the AES over the P-channel.

In the case of a call addressed to "other" GES, the procedure is similar to the above, with the addition of the log-on GES as an intermediary between the AES and "other" GES. After the call is cleared, the GES to which the channel is assigned by the NCS (i.e the "other" GES), sends the channel release information to the NCS over the interstation link. The transaction is completed by the NCS sending an acknowledgement to the GES.

In the normal case, when the call is ended both parties will replace their handsets (abnormal cases are covered in Figure I-6 and Recommendation Q.1152). The on-hook condition of the telephone in the AES initiates a series of channel release signals on the sub-band C-channel. When one of these is received in the GES, it monitors the carrier to confirm that it stops. If the AES is logged-on to another GES, the channel release signal is sent to the log-on GES via the appropriate interstation link.

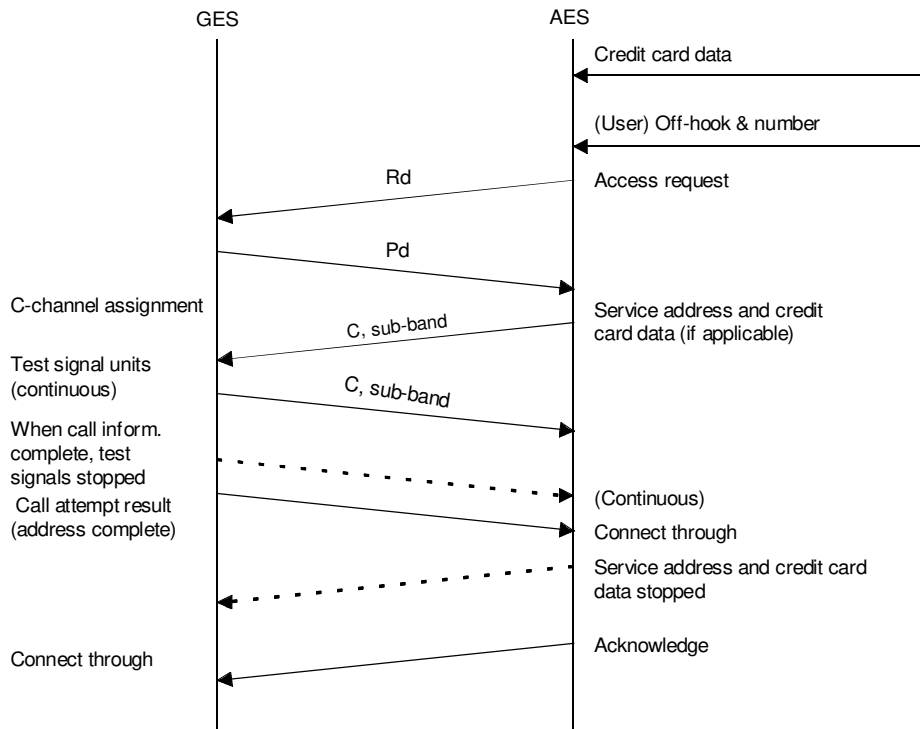

Rd See 1.3.2
Pd See 1.3.2

FIGURE I.2/Q.1151
Air-to-ground telephone call set-up sequence

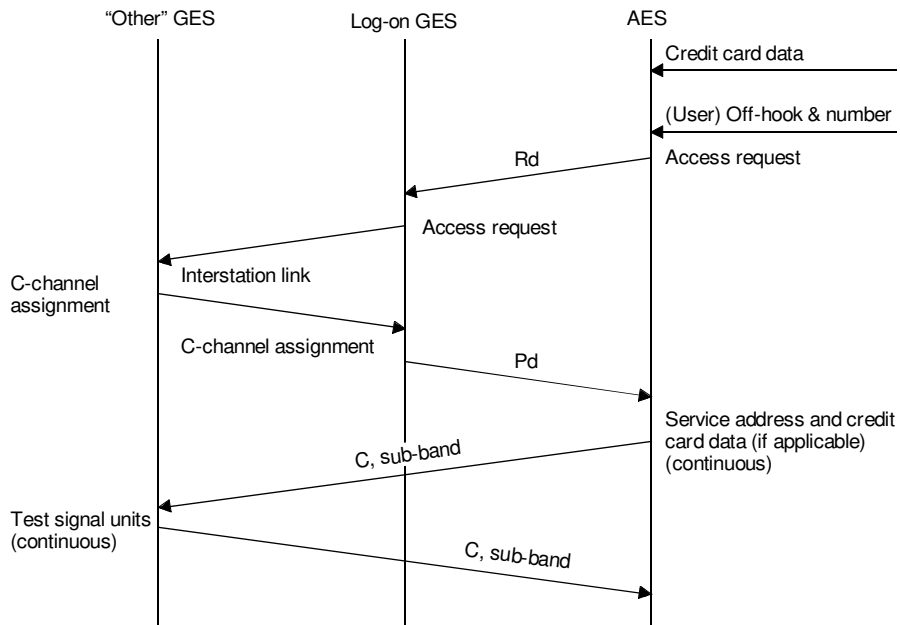

T1128300-90/d06

Further procedure is same as for air-to-ground call setup for the log-on GES

Rd See 1.3.2
Pd See 1.3.2

FIGURE I.3/Q.1151
Air-to-ground telephone call set-up sequence to other GES

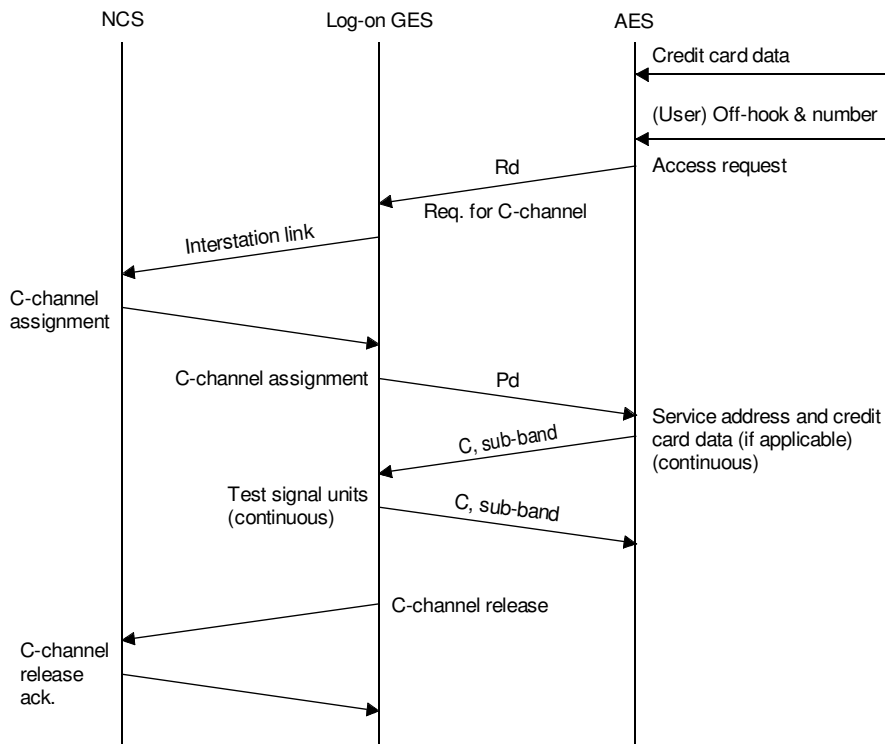

T1128310-90/d07

Further procedure is same as for air to ground call without NCS till GES monitors for carrier off after clearing

Rd See 1.3.2
Pd See 1.3.2

FIGURE I.4/Q.1151
Air-to-ground telephone call set-up sequence (overflow mode)

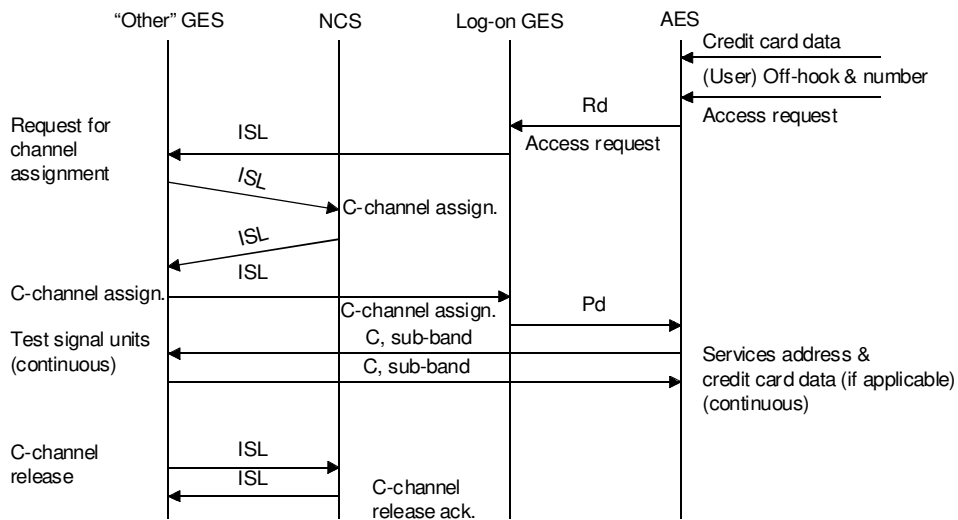

T1128320-90/d08

Further procedure is same as for air to ground call without NCS till GES monitors carrier off after clearing

ISL Interstation link
 Rd See 1.3.2
 Pd See 1.3.2

FIGURE I.5/Q.1151

Air-to-ground telephone call set-up sequence to other GES (overflow mode)

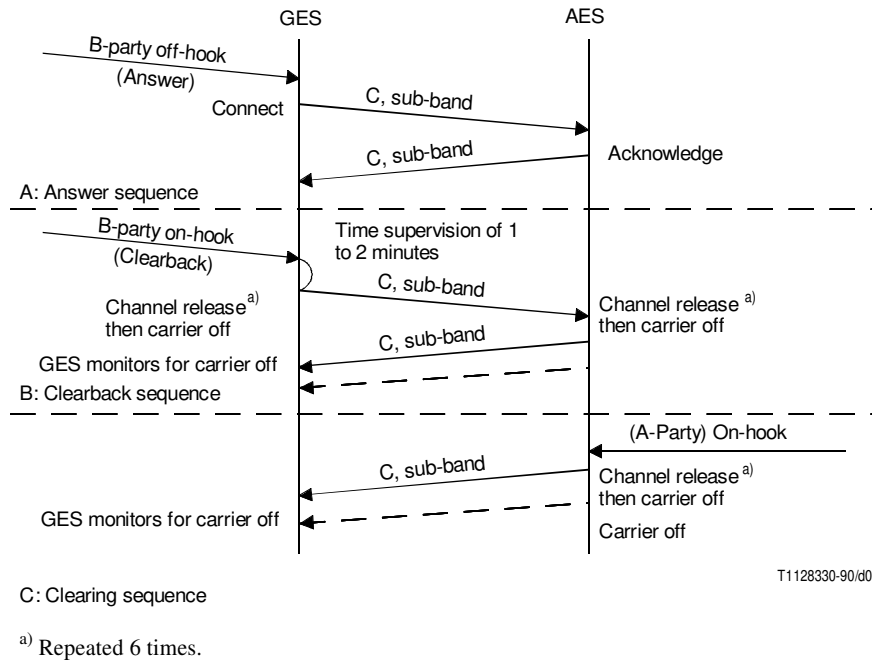

T1128330-90/d09

FIGURE I.6/Q.1151
Air-to-ground telephone call user switchhook signalling

I.6.3 Channel set-up/termination for ground-to-air calls

I.6.3.1 The sequences for ground-to-air telephone call set-up are shown in Figures I.7 to I.10 covering various cases, including use of an NCS.

I.6.3.2 From the viewpoint of the AES, all the cases are similar with the GES sending the call announcement and channel assignment information to the AES over the P-channel. After the channel assignment information is transferred to the AES, the continuity check for proper channel set-up and the eventual channel release functions of the satellite link, are carried out using signals on the sub-band C-channel.

I.6.3.3 In the case of a call from a log-on GES to an AES (Figure I.7) the only channel used prior to setting up the call is the P-channel. However, if the call is from a GES other than where the AES has logged-on (Figure I.8) the originating GES ("other" GES) sends the call announcement and channel assignment information to the log-on GES over the interstation link. The log-on GES then forwards this information to the AES over the P-channel. The signalling sequences for the cases where the call- originating GES does not have a channel in its allocated pool are shown in Figures I.9 and I.10, the former showing the case of a call originating from a log-on GES and the latter representing a call origination from a GES other than the one to which the AES has logged-on. In both cases the interstation link between the NCS and the call originating GES is used to obtain a channel from the NCS pool. After the call is cleared, the GES from which the call has originated, sends the channel release information to the NCS, which the NCS acknowledges. The procedure for call clearing (illustrated in Figure I.11) is initiated by the terrestrial network sending a clear forward signal, whereupon the GES sends a sequence of channel release signals on the sub-band C-channel. On receipt of one of these, the AES responds with a series of channel release signals, and ceases its carrier. When the GES detects the end of the AES carrier, it returns the channel to the pool.

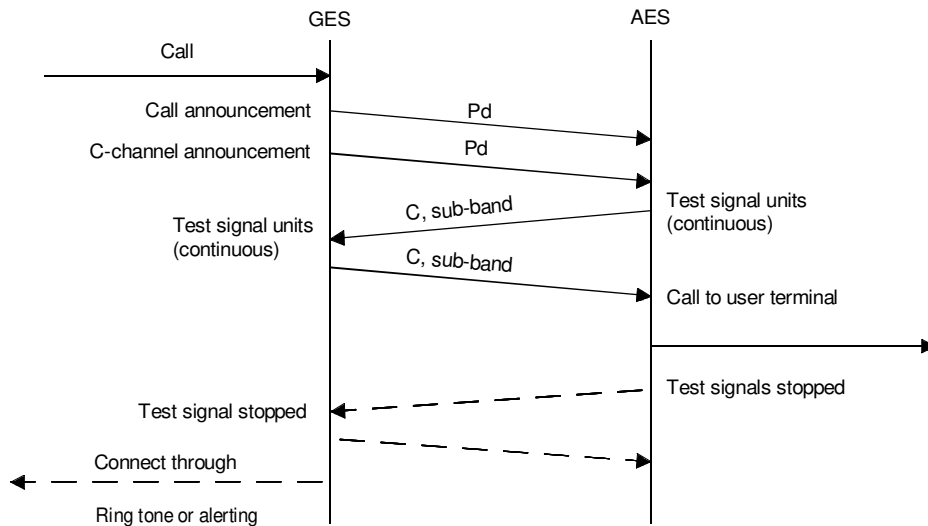

T1128340-90/d10

Pd See 1.3.2

FIGURE I.7/Q.1151
Ground-to-air telephone call set-up sequence

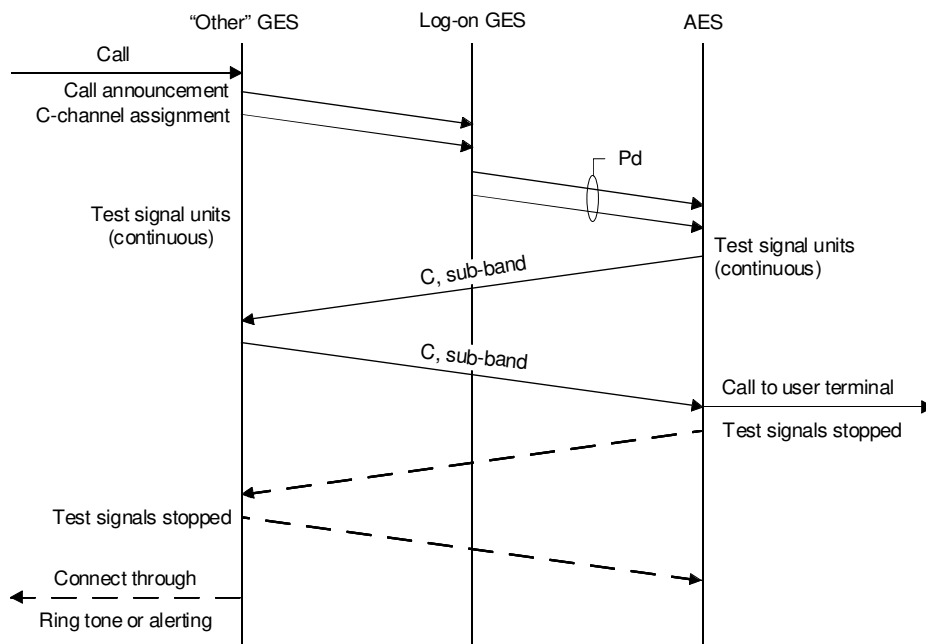

T1128350-90/d11

Pd See 1.3.2

FIGURE I.8/Q.1151
Ground-to-air call set-up sequence via other GES

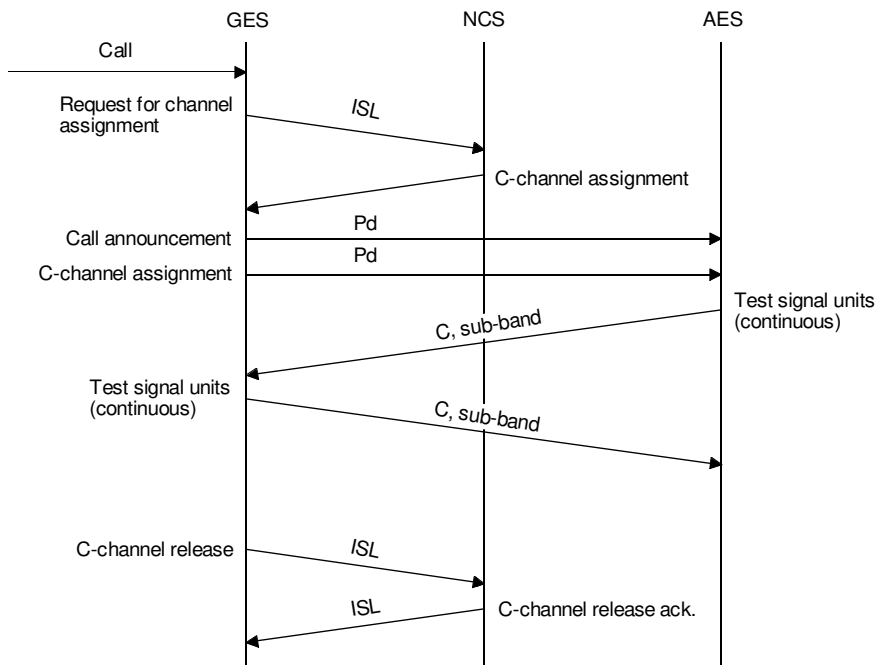

T1128360-90/d12

Further procedure is same as for air to ground call without NCS till GES monitors carrier off after clearing

ISL Interstation link
Pd See 1.3.2

FIGURE I.9/Q.1151
Ground-to-air telephone call set-up sequence (overflow mode)

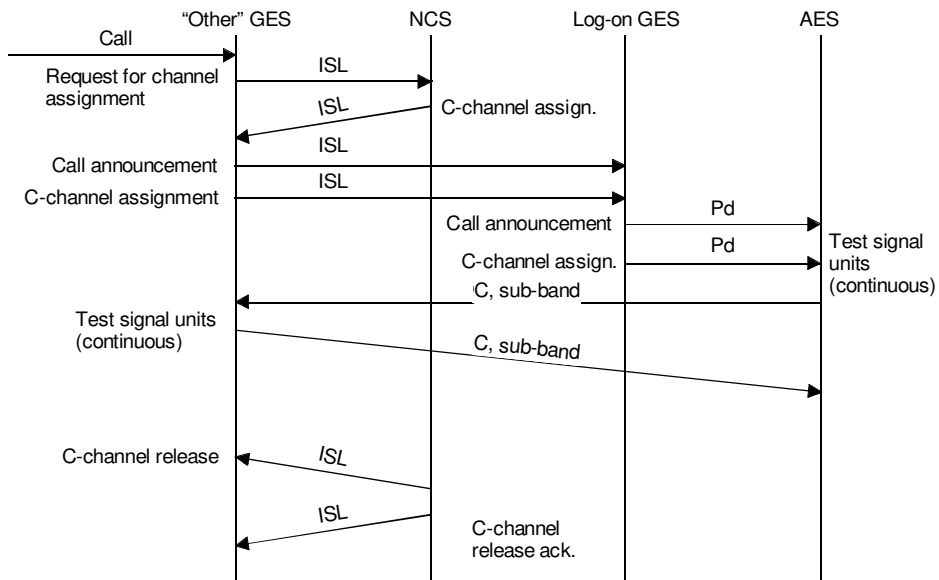

T1128370-90/d13

Further procedure is the same as for air to ground call without NCS till GES monitors for carrier off after clearing

ISL Interstation link
Pd See 1.3.2

FIGURE I.10/Q.1151

Ground-to-air telephone call set-up sequence via other GES (overflow mode)

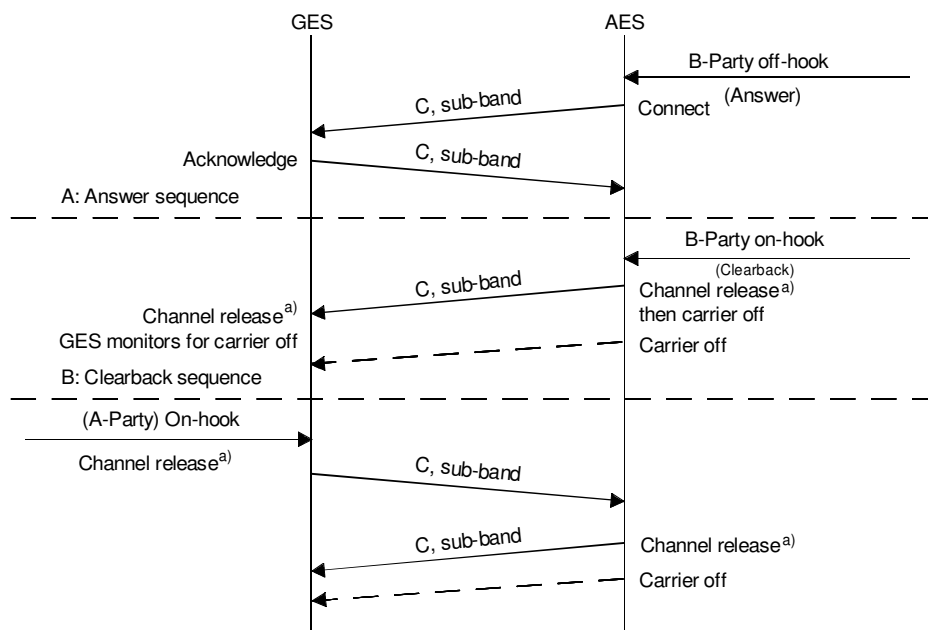

GES Monitors for carrier off
 C: Clearing sequence

T1128380-90/d14

^{a)} Repeated 6 times.

FIGURE I.11/Q.1151
Ground-to-air telephone call user switchhook signalling

I.6.4 Supervisory signalling

I.6.4.1 After call set-up, all subsequent supervisory functions are normally performed by means of subband signalling on the C-channel.

I.6.4.2 Continuity checking of the satellite voice channel is done by means of test packets transmitted on the sub-band of the C-channel.

I.6.4.3 Sub-band signalling on the C-channel is also used for answer/clearing signals, and to provide additional signalling capacity for potential future use in interworking with the terrestrial ISDNs.

I.6.4.4 Terrestrial network audible tones (ringing, busy, congestion, etc.) are passed to the AES in-band over the voice channel for air-to-ground calls. In the case of ground-to-air calls, the MSSC should return call progress and call failure causes to the terrestrial network by means of appropriate signals, from the signalling system in use. When required (due to the inadequacy of the signalling system in use), the MSSC should also generate audible tones back into the terrestrial network to the calling party.