



INTERNATIONAL TELECOMMUNICATION UNION

ITU-T

TELECOMMUNICATION
STANDARDIZATION SECTOR
OF ITU

P.78

(03/93)

**TELEPHONE TRANSMISSION QUALITY
MEASUREMENTS RELATED TO
SPEECH LOUDNESS**

**SUBJECTIVE TESTING METHOD
FOR DETERMINATION OF LOUDNESS
RATINGS IN ACCORDANCE WITH
RECOMMENDATION P.76**

ITU-T Recommendation P.78

(Previously "CCITT Recommendation")

FOREWORD

The ITU Telecommunication Standardization Sector (ITU-T) is a permanent organ of the International Telecommunication Union. The ITU-T is responsible for studying technical, operating and tariff questions and issuing Recommendations on them with a view to standardizing telecommunications on a worldwide basis.

The World Telecommunication Standardization Conference (WTSC), which meets every four years, established the topics for study by the ITU-T Study Groups which, in their turn, produce Recommendations on these topics.

ITU-T Recommendation P.78 was revised by the ITU-T Study Group XII (1988-1993) and was approved by the WTSC (Helsinki, March 1-12, 1993).

NOTES

1 As a consequence of a reform process within the International Telecommunication Union (ITU), the CCITT ceased to exist as of 28 February 1993. In its place, the ITU Telecommunication Standardization Sector (ITU-T) was created as of 1 March 1993. Similarly, in this reform process, the CCIR and the IFRB have been replaced by the Radiocommunication Sector.

In order not to delay publication of this Recommendation, no change has been made in the text to references containing the acronyms "CCITT, CCIR or IFRB" or their associated entities such as Plenary Assembly, Secretariat, etc. Future editions of this Recommendation will contain the proper terminology related to the new ITU structure.

2 In this Recommendation, the expression "Administration" is used for conciseness to indicate both a telecommunication administration and a recognized operating agency.

© ITU 1994

All rights reserved. No part of this publication may be reproduced or utilized in any form or by any means, electronic or mechanical, including photocopying and microfilm, without permission in writing from the ITU.

CONTENTS

	<i>Page</i>
1 Introduction	1
2 General	1
3 Experiment design	2
4 Selection of crew members and speech material	5
5 Calibration of the IRS	5
6 Circuit arrangements	5
7 Recording of information	7
7.1 Details of the test	7
7.2 Individual balances	7
8 Analysis	7
9 Presentation of results	7
Annex A – Examples of experiment designs	11
Annex B – Selection of crew members, audiometric testing of subjects and speech material	13
B.1 Crew members	13
B.2 Audiometric testing of subjects – simple screening procedure	14
B.3 Speech material.....	14
Annex – C Simplified statistical analysis	15
C.1 Mean	15
C.2 Standard deviation	15
References.....	15

PREFACE

This Recommendation describes a subjective testing method which has been found suitable for laboratories' purposes. Provided that the Intermediate Reference System (IRS) used complies with the requirements of Recommendation P.48 and that other requirements given in Recommendation P.76 are adhered to, the loudness ratings obtained by using the method given in the present Recommendation can be used for verifying the objectively measured loudness ratings of telephone systems with special characteristics. The present Recommendation, together with Recommendations P.76 and P.48, provides a definition of loudness ratings which can be used for planning.

SUMMARY

This Recommendation contains the essential particulars for defining the method for determining loudness ratings in accordance with Recommendation P.76 when use is made of subjects performing equal loudness balances. Details are included concerning the balancing method, choice of subjects, speech material, design of experiment, method of analysis and presentation of results.

Study is continuing on using a direct-balance method. A description of this method can be found in Supplement No. 17 to Series P Recommendations.

SUBJECTIVE TESTING METHOD FOR DETERMINATION OF LOUDNESS RATINGS IN ACCORDANCE WITH RECOMMENDATION P.76

(amended at Malaga-Torremolinos, 1984; Melbourne, 1988 and Helsinki, 1993)

1 Introduction

To compare the calculation of loudness ratings method (see Recommendation P.79) a defined method of subjectively determining loudness ratings is required. This Recommendation deals with all aspects of a test from selection of operators to the method of analysis and finally presentation of results.

2 General

In the subjective comparisons, the Fundamental Reference System (FRS) is used (although other reference systems are permissible) as the datum for comparing the following speech paths:

- a) *Path 0* – The fundamental reference system always provides the speech path against which each of the others is balanced. NOSFER set at 25 dB is used.
- b) *Path 1* – The send end of the test (“unknown”) local telephone circuit connected through the test (“unknown”) junction and an adjustable attenuator to the receive end of the test (“unknown”) local telephone circuit. The adjustable attenuator must be inserted in such a manner that the impedance relationships between the three parts of the connection (send end, junction and receive end) are not disturbed.
- c) *Path 2* – The send end of the intermediate reference system connected through an adjustable attenuator to the receive end of the intermediate reference system.
- d) *Path 3* – The send end of the test (“unknown”) local telephone circuit connected through an adjustable attenuator to the receive end of the IRS.
- e) *Path 4* – The send end of the IRS connected through an adjustable attenuator to the receive end of the test (“unknown”) local telephone system.
- f) *Path 5* – The send end of the IRS connected through the test (“unknown”) junction and an adjustable attenuator to the receive end of the IRS. The adjustable attenuator must be inserted in such a manner that the impedance relationships between the three parts of the connection (send end, junction and receive end) are not disturbed.

In these subjective comparisons, the junction of the fundamental reference system is fixed, i.e. the level of speech sounds received via the fundamental reference system is kept constant, the loudness balance being obtained by the so-called “margin” method, and the balance attenuator being that inserted in the telephone (or IRS) path being tested.

The speaking position used with both the IRS and the test telephone sets should be as defined in Annex A/P.76.

Figure 1 shows the composition of the telephone paths to be compared. The balances should be conducted using the vocal level defined in Recommendation P.72.

The loudness ratings relative to the IRS as defined in Recommendation P.76 are:

$$\text{OLR} = x_2 - x_1$$

$$\text{SLR} = x_2 - x_3$$

$$\text{RLR} = x_2 - x_4$$

$$\text{JLR} = x_2 - x_5$$

It is not necessary to include all the paths indicated above in every experiment. Paths 0 and 2 are essential but addition of only 3 and 4 is sufficient to determine sending and receiving loudness ratings of a local telephone circuit. Paths 0, 2 and 5 are required to determine a junction loudness rating. Path 1 is usually required only when it is derived to verify additivity of loudness ratings, namely that:

$$ORL = SLR + JLR + RLR$$

3 Experiment design

To have confidence in results requires the correct testing procedures to be followed, coupled with the correct experiment design. The procedure should be prepared such that no ambiguity can exist.

The following points must be considered in the design:

- a) The experiment should be designed in such a way that all uncontrolled influences operate at random, e.g. slight day-to-day drift of subjects and/or measuring equipment.
- b) If more balances are required than can be comfortably completed in one day, then the experiment must be designed such that equal numbers of each type of system are completed each day.
- c) The operators who start a test should always be the same throughout the test [1].
- d) A minimum of 12 operator-pair combinations is suggested with a maximum of 20. Twelve operator-pair combinations can be arrived at from two crews of 3 (see Table 1a) or one crew of 4 and 18 operator-pair combinations can be arrived at from one crew of 6 (see Table 1b) and 20 operator-pair combinations from one crew of 5 (see Table 2a).

NOTE – One crew of 6 giving 30 operator-pair combinations (see Table 2b) produces a larger test for only slightly more precision than the previously mentioned crew sizes.

TABLE 1a/P.78

**Twelve operator-pair combinations
from two crews of three, known as
3/6 operator method**

		Operator (listener)					
		A	B	C	D	E	F
Operator (talker)	A		X	X			
	B	X		X			
	C	X	X				
	D				X	X	
	E				X		X
	F				X	X	

TABLE 1b/P.78

**Eighteen operator-pair combinations
from one crew of six, known as
3/6' operator method**

		Operator (listener)					
		A	B	C	D	E	F
Operator (talker)	A				X	X	X
	B				X	X	X
	C				X	X	X
	D	X	X	X			
	E	X	X	X			
	F	X	X	X			

- e) When using two crews of 3, one can use both crews interleaved but it is generally more practical to separate the crews and use test crew 1 before crew 2. Members should not be used in both crews as it causes a bias and complicates the analysis.
- f) All operator-pair combinations should be tested in rotation, where practical, such that each operator takes a turn as talker, then listener and then has a break.

TABLE 2a/P.78

**Twenty operator-pair combinations
from one crew of five, known as
5/5 operator method**

		Operator (listener)				
		A	B	C	D	E
Operator (talker)	A		X	X	X	X
	B	X		X	X	X
	C	X	X		X	X
	D	X	X	X		X
	E	X	X	X	X	

TABLE 2b/P.78

**Thirty operator-pair combinations
from one crew of six, known as
6/6 operator method**

		Operator (listener)					
		A	B	C	D	E	F
Operator (talker)	A		X	X	X	X	X
	B	X		X	X	X	X
	C	X	X		X	X	X
	D	X	X	X		X	X
	E	X	X	X	X		X
	F	X	X	X	X	X	

- g) The design of the experiment should eliminate any effect that could be attributed to the order of presentation. That is to say that all systems should be in a randomized order. To illustrate this point two examples are as follows:

Example 1

If one type of loudness rating is required, with a given combination of telephone set and circuit condition, then the experiment design must allow for any effect associated with order of presentation for each operator-pair combination. An example is shown in Table 3.

NOTE – However, if a laboratory has found with sufficient evidence that this method of design is not necessary, then a simplified design may be used.

TABLE 3/P.78

**Example to illustrate the elimination of order of presentation effect
for one type of loudness rating**

Operator-pairs	Talker Listener	A B	B C	C A
Circuits	α	3	1	2
	α'	2	3	4
	β	1	4	3
	β'	4	2	1

α = path 0 presented before path traject 2
 α' = path 2 presented before path traject 0
 β = path 0 presented before path traject 3
 β' = path 3 presented before path traject 0

NOTE – When it is proven that there is no difference for a given test crew and set of test conditions, the distinction between the order of path presentation can be eliminated.

Example 2

Now, if more than one type of loudness rating is made or more than one telephone set is used, then there need only be one balance of path 2 against path 0 and vice-versa per operator-pair combination for any experiment, but this must be randomized within the experiment. An example is shown in Table 4.

Some experiment designs can be found in Annex A.

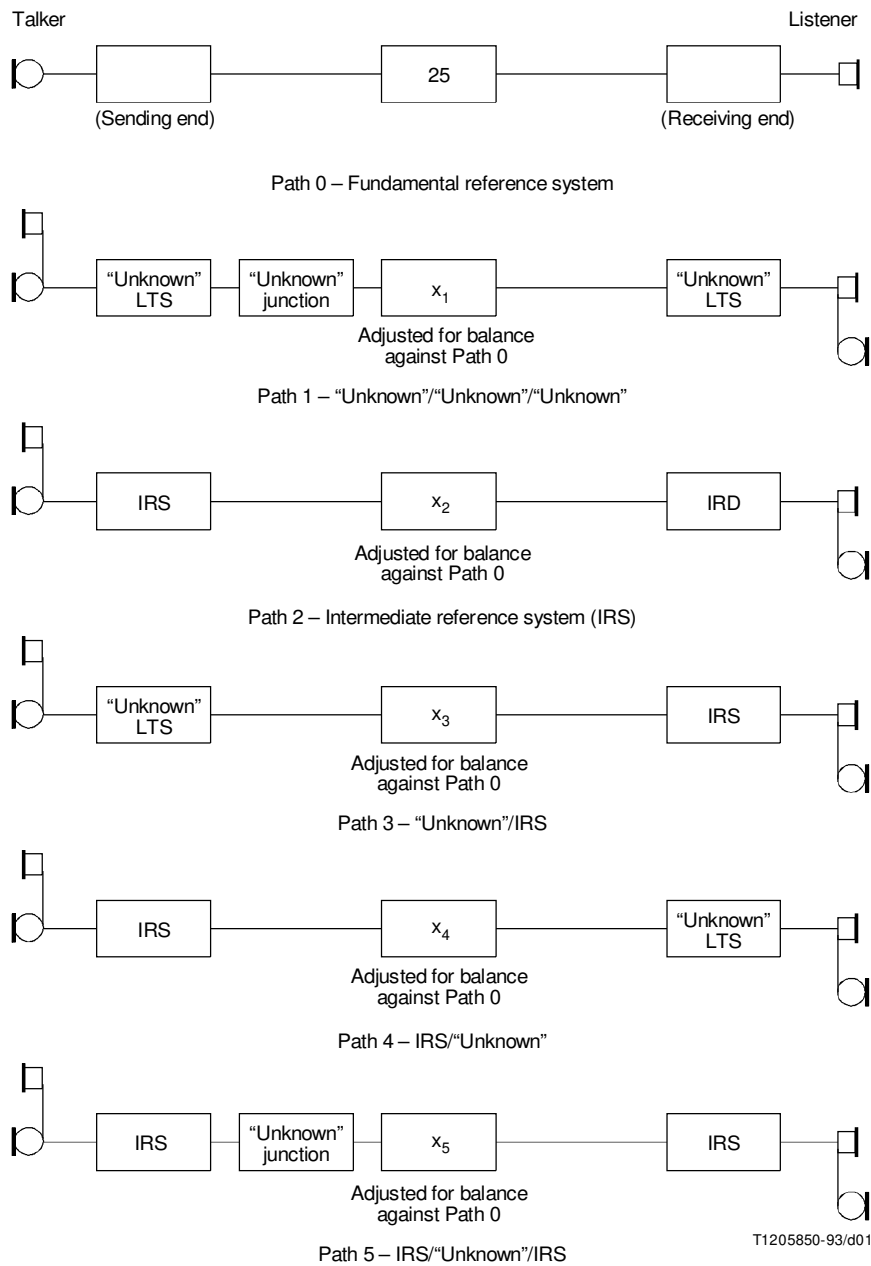

NOTE – Direct loudness balance of the “unknown” system against the IRS is also possible (see Supplement No. 17 Series P Recommendations).

FIGURE 1/P.78
 Arrangement of paths for subjective method of determination of loudness ratings

TABLE 4/P.78

**Example to illustrate the elimination of order of presentation effect
for two type of loudness rating**

Operator-pairs	Talker Listener	A B	B C	C A
Circuits	α	3	1	2
	α'	5	4	6
	β_1	1	2	5
	β'_1	6	5	3
	β_2	2	6	4
	β'_2	4	3	1

β_1, β'_1 = have, for example, 0 km of subscriber's cable
 β_2, β'_2 = have, for example, 6 km of subscriber's cable

4 Selection of crew members and speech material

Requirements for the selection of crew members including audiometric testing of subjects, as well as the speech material used by the crew for subjective tests, can be found in Annex B.

5 Calibration of the IRS

It is most important that the calibration of the IRS is made before every test so that any small change in SLR and RLR can either be compensated for in the results or the sensitivity can be changed before the test. It is good experimental practice to check the sensitivity of the IRS after each experiment. The specification of the IRS is found in Recommendation P.48 and the description of the calibration procedure is found in Recommendation P.64. The results of the calibration are used to determine the corrections to the subjective balance results (see clause 9).

6 Circuit arrangements

Figure 2a) shows a typical circuit layout for the measurement of SLR and RLR. Figures 2b) and 2c) show layouts for the measurement of JLR and OLR respectively. There is no reason if the experimenter so wished, why all four types of loudness rating cannot be tested in the same experiment. This, however, would require extremely intricate switching arrangements.

In Figures 2a), 2b) and 2c) the 600 ohm on the second position of switch S1 allows the correct speech level to be set when path 0 is presented after path 1/2/3/4/5 (see Figure 1). This switch should be of the non-locking type and should be returned to the normal position as soon as the talker has attained the correct speech level.

In order to reduce the effect of sidetone on the talker's vocal level during sending and overall determinations, the acoustic sidetone path of handset telephones should be disabled. This can be accomplished by placing the earphone in another identical handset and the electrical connections made to the correct terminals on the telephone transmission circuit. The earphone can then be sealed to an IEC/CCITT artificial ear to give the correct acoustic loading. A simpler method, used by the Australian Post Office, is to seal the earphone by means of heavy tape. Although this might not have the correct acoustic loading, in practice it has been found to have a negligible effect.

If the microphone is of the carbon-granule type, then before each balance the conditioning procedure according to Recommendation P.75 should be used.

In Figures 1 and 2 the fundamental reference system, NOSFER, has been shown but other types such as SETED and METRE-AIR-PATH could be used.

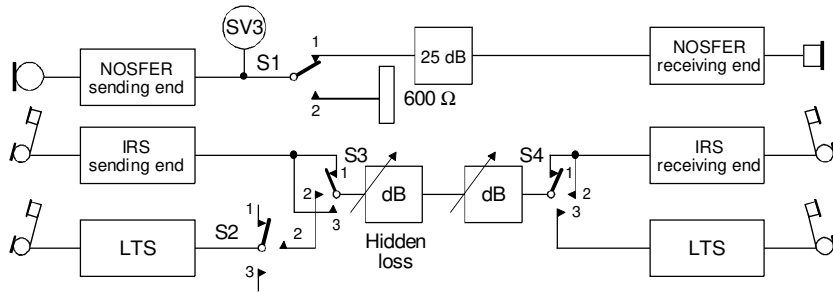

NOTE – S1 is a nonlocking switch. S2, S3 and S4 are all ganged.

a) Switching diagram for the measurement of SLR and RLR

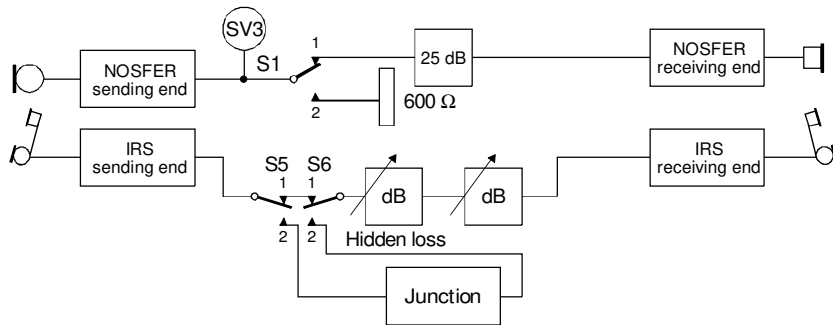

NOTE – S1 is a nonlocking switch. S5 and S6 are ganged.

b) Switching diagram for the measurement of JLR

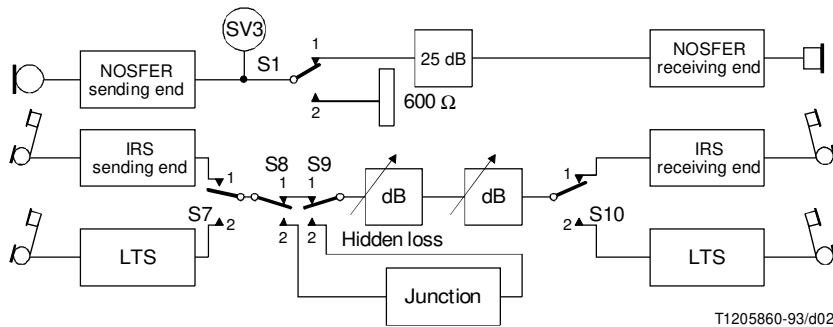

T1205860-93/d02

NOTE – S1 is a nonlocking switch. S7, S8, S9 and S10 are all ganged.

c) Switching diagram for the measurement of OLR

FIGURE 2/P.78

7 Recording of information

It is essential that as much information of any test should be recorded, in such a way that at any time in the future, the information can be retrieved.

7.1 Details of the test

Each test should always include the following information:

- a) test No. – this should be unique so that one test cannot be confused with another;
- b) date;
- c) title – a brief description of the test;
- d) circuit conditions – describe each individual path;
- e) diagram to show switching arrangement;
- f) crew members – name each operator and assign a code, as for example in Table 5. Then each operator-pair combination can be denoted by a code, e.g. A-B.

TABLE 5/P.78

Crew members	
Code	Operator
A	
B	
C	
D	
E	
F	

7.2 Individual balances

These should always include the “hidden loss” attenuation, the “balance” attenuation and finally the result of the comparison, e.g.

$$R = H + B$$

where

R is the result,

H is the hidden loss,

B is the balance.

8 Analysis

For any experiment most information can be obtained from an analysis of variance. However, sufficient useful information can be derived using the mean, standard deviation. The method of calculation of these parameters can be found in Annex C.

9 Presentation of results

The results of the test should be presented such that the important information can be displayed on one form. An example of such a form is shown in Table 6.

NOTE – In Tables 6 to 8 corrected mean = mean + correction.

Worked examples of the use of the form shown in Table 6 are shown in Tables 7 and 8. The form has been modified to allow SLR and RLR determinations to be made on a local telephone system including two line lengths. Table 7 shows the SLR results and Table 8 the RLR results.

TABLE 6/P.78

Presentation of results

Frequency (Hz)	IRS sending sensitivity (dBV/Pa)	IRS receiving sensitivity ^{a)} (dBPa/V)	Operator- pair	x_0 (dB)	x_2 (dB)	x'_2 (dB)	x_3 (dB)	x'_3 (dB)	x_2 (dB)	x'_2 (dB)	x_4 (dB)	x'_4 (dB)	SLR (dB)	SLR' (dB)	RLR (dB)	RLR' (dB)	$\frac{SLR + SLR'}{2}$ (dB)	$\frac{RLR + RLR'}{2}$ (dB)
100																		
125																		
160																		
200																		
250																		
315																		
400																		
500																		
630																		
800																		
1000																		
1250																		
1600																		
2000																		
2500																		
3150																		
4000																		
5000																		
6300																		
8000																		
Calculated LR of IRS			Mean: dB															
			Std. dev.: dB															
			95% confidence limits: dB															
				Corrected mean: dB														
a) Artificial ear conforming to Recommendation P.51.																		

TABLE 7/P.78

Example to illustrate the use of the form shown in Table 6 for the determination of SLR

Frequency (Hz)	IRS sending sensitivity (dBV/Pa)	IRS receiving sensitivity ^{a)} (dBPa/V)	Operator- pair	x_0	x_2	x'_2	x_3	x'_3	x_2	x'_2	x_3	x'_3	SLR	SLR'	SLR	SLR'	$\frac{SLR + SLR'}{2}$	$\frac{SLR + SLR'}{2}$
				(dB)	(dB)	(dB)	(0) (dB)	(0) (dB)	(dB)	(dB)	(L) (dB)	(L) (dB)	(0) (dB)	(0) (dB)	(L) (dB)	(L) (dB)	(0) (dB)	(L) (dB)
100			A-C	25	14	15	13	14			12	10	1	1	2	5	1.0	3.5
125			D-A	25	13	13	8	10			10	11	5	3	3	2	4.0	2.5
160			C-D	25	10	11	7	11			10	11	3	0	0	0	1.5	0.0
200	-19.7		D-C	25	12	14	11	10			10	11	1	4	2	3	2.5	2.5
250	-15.3		C-A	25	17	17	17	13			12	14	0	4	5	3	2.0	4.0
315	-12.2		A-D	25	10	12	8	10			10	8	2	2	0	4	2.0	2.0
400	-9.6		F-E	25	11	11	7	7			5	4	4	4	6	7	4.0	6.5
500	-8.0		B-F	25	10	11	6	8			5	7	4	3	5	4	3.5	4.5
630	-6.7		E-B	25	13	12	8	13			8	9	5	-1	5	3	2.0	4.0
800	-5.9		E-F	25	13	13	12	11			12	8	1	2	1	5	1.5	3.0
1000	-5.6		F-B	25	12	13	9	5			5	6	3	8	7	7	5.5	7.0
1250	-4.2		B-E	25	12	13	9	9			9	10	3	4	3	3	3.5	3.0
1600	-1.2																	
2000	0																	
2500	+1.0																	
3150	+0.3																	
4000	-36.5																	
5000																		
6300																		
8000																		
Calculated LR of IRS	1.09		Mean: dB	25	12.25	12.92	9.58	10.08			9.00	9.08	2.67	2.83	3.25	3.83	2.75	3.54
			Std. dev.: dB	0	1.92	1.71	3.01	2.50			2.58	2.56	1.60	2.23	2.24	1.91	1.28	1.82
			95% confidence limits: dB	0	1.22	1.08	1.91	1.59			1.64	1.63	1.02	1.42	1.42	1.21	0.81	1.16
			Corrected mean: dB												3.76	3.92	4.34	4.92

a) Artificial ear conforming to Recommendation P.51.

TABLE 8/P.78

Example to illustrate the use of the form shown in Table 6 for the determination of RLR

Frequency (Hz)	IRS sending sensitivity (dBV/Pa)	IRS receiving sensitivity ^{a)} (dBPa/V)	Operator- pair	x_0	x_2	x'_2	x_4	x'_4	x_2	x'_2	x_4	x'_4	RLR	RLP'	RLR	RLR'	$\frac{\text{RLR} + \text{RLR}'}{2}$	$\frac{\text{RLR} + \text{RLR}'}{2}$
				(dB)	(dB)	(dB)	(0) (dB)	(0) (dB)	(dB)	(dB)	(L) (dB)	(L) (dB)	(0) (dB)	(0) (dB)	(L) (dB)	(L) (dB)	(0) (dB)	(L) (dB)
100			C-B	25	10	11	20	20			15	13	-10	-9	-5	-2	-9.5	-3.5
125			B-E	25	15	9	19	21			13	13	-4	-12	2	-4	-8.0	-1.0
160			B-C	25	14	17	23	23			17	14	-9	-6	-3	3	-7.5	0.0
200		-3.8	E-B	25	11	10	19	19			13	15	-8	-9	-2	-5	-8.5	-3.5
250		2.0	C-E	25	8	11	16	18			14	15	-8	-7	-6	-4	-7.5	-5.0
315		6.6	E-C	25	13	13	18	18			13	16	-5	-5	0	-3	-5.0	-1.5
400		9.8	D-F	25	8	9	13	13			12	9	-5	-4	-4	0	-4.5	-2.0
500		11.2	F-A	25	14	14	22	21			17	16	-8	-7	-3	-2	-7.5	-2.5
630		12.1	D-A	25	12	10	18	18			13	13	-6	-8	-1	-3	-7.0	-2.0
800		12.8	A-D	25	12	8	21	19			12	11	-9	-11	0	-3	-10.0	-1.5
1000		13.4	A-F	25	10	9	15	18			9	9	-5	-9	1	0	-7.0	0.5
1250		13.8	F-D	25	11	9	19	16			10	10	-8	-7	1	-1	-7.5	0.0
1600		14.0																
2000		13.2																
2500		11.0																
3150		10.4																
4000		-15.8																
5000																		
6300																		
8000																		
Calculated LR of IRS		-0.16	Mean: dB	25	11.50	10.83	18.58	18.67			13.17	12.83	-7.08	-7.83	-1.67	-2.00	-7.46	-1.83
			Std. dev.: dB	0	2.18	2.51	2.75	2.46			2.30	2.44	1.89	2.23	2.46	2.12	1.51	1.56
			95% confidence limits: dB	0	1.38	1.59	1.75	1.56			1.46	1.55	1.20	1.42	1.56	1.35	0.96	0.99
			Corrected mean: dB										-7.24	-7.99	-1.83	-2.16	-7.62	-1.99

a) Artificial ear conforming to Recommendation P.51.

Annex A

Examples of experiment designs

(This annex forms an integral part of this Recommendation)

Tables A.2, A.3 and A.4, give typical designs for different crew sizes.

As an example, using Table A.2, the order of balances is as given in Table A.1.

The operator-pairs in rotation do all balances in numerical order starting with “1” and finishing with “6”.

Similar tables can be drawn up for a test requiring only one type of loudness rating where only 4 circuits are required e.g. α , α' , β and β' for a SLR test, where numbers 1, 2, 3 and 4 would be assigned respectively in the experiment design.

For a test involving more circuits the same principles can be followed assigning as many numbers as there are circuits.

It may be necessary to improve the validity of results and a replication of the same experiment design using the same operator-pairs can be made.

TABLE A.1/P.78

Balance No.	Operator-pair	Circuit
1	BA	β_1
2	CB	α
3	DC	β_2
13	BA	β'_1
14	CB	β_1
15	DC	β'_2
25	BA	β_2
26	CB	β'_2
27	DC	α
71	AC	β_1
72	DA	α'

TABLE A.2/P.78

Design for one crew of 4 or two crews of 3

One crew of 4 Operator-pairs Two crews of 3	Talker Listener	B A	C B	D C	A D	C A	B D	A B	B C	C D	D B	A C	D A
	Talker Listener	B A	C B	A C	C A	B C	A B	E D	F E	D F	F D	E F	D E
Circuits	α	4	1	3	2	6	5	3	6	1	5	4	2
	α'	6	5	4	3	2	1	2	4	5	3	1	6
	β_1	1	2	5	6	3	4	5	3	2	1	6	4
	β'_1	2	4	6	5	1	3	4	2	3	6	5	1
	β_2	3	6	1	4	5	2	6	1	4	2	3	5
	β'_2	5	3	2	1	4	6	1	5	6	4	2	3

TABLE A.3/P.78

Design for one crew of 6

Operator-pairs	Talker Listener	D A	E B	F C	E A	F B	D C	F A	D B	E C	A D	B E	C F	A E	B F	C D	A F	B D	C E
	Circuits	α	4	1	3	2	6	5	3	6	1	5	4	2	1	2	6	3	5
α'		6	5	4	3	2	1	2	4	5	3	1	6	5	4	1	6	2	3
β_1		1	2	5	6	3	4	5	3	2	1	6	4	4	6	2	1	3	5
β'_1		2	4	6	5	1	3	4	2	3	6	5	1	3	1	4	5	6	2
β_2		3	6	1	4	5	2	6	1	4	2	3	5	6	5	3	2	4	1
β'_2		5	3	2	1	4	6	1	5	6	4	2	3	2	3	5	4	1	6

TABLE A.4/P.78

Design for one crew of 5

Operator-pairs	Talker Listener	B A	C B	D C	E D	A E	C A	E C	B E	D B	A D	D A	B D	E B	C E	A C	E A	D E	C D	B C	A B
	Circuits	α	4	1	3	2	6	5	3	6	1	5	4	2	1	2	6	3	5	4	1
α'		6	5	4	3	2	1	2	4	5	3	1	6	5	4	1	6	2	3	2	5
β_1		1	2	5	6	3	4	5	3	2	1	6	4	4	6	2	1	3	5	3	4
β'_1		2	4	6	5	1	3	4	2	3	6	5	1	3	1	4	5	6	2	4	3
β_2		3	6	1	4	5	2	6	1	4	2	3	5	6	5	3	2	4	1	5	2
β'_2		5	3	2	1	4	6	1	5	6	4	2	3	2	3	5	4	1	6	6	1

Annex B

Selection of crew members, audiometric testing of subjects and speech material

(This annex forms an integral part of this Recommendation)

B.1 Crew members

The crew should, wherever possible, contain an equal number of both men and women.

The following points are a guide for selection:

- a) Good hearing – no operator should exceed a hearing loss of a 15 dB at all frequencies up to and including 4 kHz and no more than 25 dB at 8 kHz. This is shown in Figure B.1. If it is intended that contra-lateral balances are required and this necessitates the use of both ears, then the maximum difference between ears should be ± 10 dB at all frequencies. An example of an audiometric testing procedure of subjects is presented below in B.2.
- b) Clear speech – each operator should be free from obvious speech impediments.
- c) The operator should be able to work harmoniously with other people.
- d) The operator should be able to make simple arithmetical calculations.
- e) The operator should be able to talk at a constant level, with the aid of a meter, after sufficient training.
- f) The operator must not suffer from claustrophobia as each operator must, during the test, spend a certain amount of short-term solitary confinement.
- g) Regular checks should be made to determine the performance of each operator as both a talker and as a listener to disclose any unusual changes. A full description can be found in Reference [2].

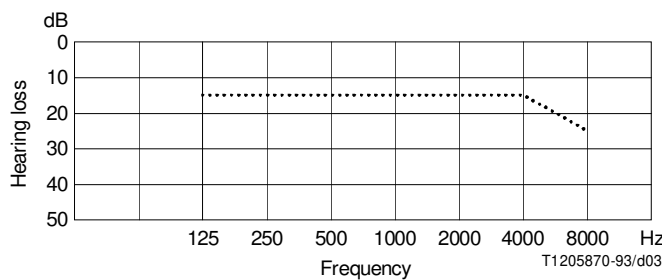

NOTE – Nominal hearing is at 0 dB.

FIGURE B.1/P.78
Mask of maximum loss of hearing of subjects

B.2 Audiometric testing of subjects – simple screening procedure [3]

B.2.1 Visual examination of ears for wax, ask if subject has a cold, sinusitis or any other abnormality.

B.2.2 Frequencies of test

125, 250, 500, 1000, 2000, 3000, 4000, 6000, 8000 Hz.

B.2.3 Example of presentation

1000, 2000, 3000, 4000, 6000, 8000, 125, 250, 500, 1000 Hz.

NOTE – It is common for the second reading at 1000 Hz to be lower than the first.

Follow the above sequence for one ear, then repeat for the other ear.

B.2.4 Example of finding threshold:

Start above estimated threshold (say 20 dB hearing loss), approach in 10 dB steps until inaudible (no response). Return to last audible level and descend in 5 dB steps. Then approach this threshold from below in 5 dB steps. Signal duration 1 to 2 seconds.

Threshold is that value at which two equal responses are obtained from four successive stimuli.

B.2.5 Room noise [4]

Using supra-aural type headsets the maximum permissible levels in the test room are given in Table B.1.

If circum-aural type headsets are used, then it is normally permissible to allow higher levels of noise.

TABLE B.1/P.78

Octave band	Sound pressure level (dB)
125	22.0
250	16.0
500	18.0
1000	26.0
2000	36.0
3000	39.5
4000	38.5
6000	40.0
8000	34.5

B.3 Speech material

The test phrase or phrases can be either a “nonsense” or “meaningful” phrase. Examples are:

- a) Joe took father’s shoe bench out;
- b) Paris – Bordeaux – Le Mans – Saint-Leu – Léon – Loudun.

Due consideration should be given to the following points:

- i) The ability of each operator to pronounce the chosen test phrase or phrases fluently and at a steady speech level. The sound structure of the native languages of the operators has therefore a bearing on the choice of test phrase or phrases.
- ii) The phrase or phrases should be chosen so that the agreed measurement method to control the speech level (i.e. deflection of meter) can give a consistent and readily appreciated indication of vocal level.

Annex C

Simplified statistical analysis

(This annex forms an integral part of this Recommendation)

C.1 Mean

The mean is obtained by using the following formula:

$$\bar{x} = \frac{\sum x}{n}$$

C.2 Standard deviation

It cannot be assumed that the operators are a sample drawn at random from a population and that the operator-pair combinations are independent of each other. Under these circumstances the standard deviation must be of the sample and not an estimate of a population.

The formula for the standard deviation is

$$\sigma = \sqrt{\frac{\sum (x - \bar{x})^2}{n}}$$

C.3 A more detailed statistical analysis is possible to calculate confidence intervals as explained in 1.3.4 of the *Handbook on Telephony* [5]. The confidence interval is governed by the dispersion between the crew members, the number of crew members and the arrangement of the experimental design. Typical values in a well-conducted test are ± 5 dB for the arrangements shown in Table 1a, ± 4 dB for Table 1b, ± 3 dB for Table 2a, and ± 2 dB for Table 2b.

References

- [1] *The design and analysis of loudness efficacy measurements*, Red Book, Vol. V, Annex 7, ITU, Geneva, 1962.
- [2] *Extract from a study of the differences between results for individual crew members in loudness balance tests*, Red Book, Vol. V, Annex 6, p. 214, ITU, Geneva, 1962.
- [3] BURNS (W.): *Noise and man*, Murray, pp. 70-80, 1968.
- [4] *Ibid.*, pp. 298-300.
- [5] *CCITT Handbook on Telephony*, second edition, ITU, Geneva, 1993.