



INTERNATIONAL TELECOMMUNICATION UNION

ITU-T

TELECOMMUNICATION
STANDARDIZATION SECTOR
OF ITU

N.1

(03/93)

**MAINTENANCE OF INTERNATIONAL
SOUND-PROGRAMME AND TELEVISION
TRANSMISSION CIRCUITS**

**DEFINITIONS FOR APPLICATION TO
INTERNATIONAL SOUND-PROGRAMME
AND TELEVISION-SOUND TRANSMISSION**

ITU-T Recommendation N.1

(Previously "CCITT Recommendation")

FOREWORD

The ITU Telecommunication Standardization Sector (ITU-T) is a permanent organ of the International Telecommunication Union. The ITU-T is responsible for studying technical, operating and tariff questions and issuing Recommendations on them with a view to standardizing telecommunications on a worldwide basis.

The World Telecommunication Standardization Conference (WTSC), which meets every four years, established the topics for study by the ITU-T Study Groups which, in their turn, produce Recommendations on these topics.

ITU-T Recommendation N.1 was revised by the ITU-T Study Group IV (1988-1993) and was approved by the WTSC (Helsinki, March 1-12, 1993).

NOTES

1 As a consequence of a reform process within the International Telecommunication Union (ITU), the CCITT ceased to exist as of 28 February 1993. In its place, the ITU Telecommunication Standardization Sector (ITU-T) was created as of 1 March 1993. Similarly, in this reform process, the CCIR and the IFRB have been replaced by the Radiocommunication Sector.

In order not to delay publication of this Recommendation, no change has been made in the text to references containing the acronyms "CCITT, CCIR or IFRB" or their associated entities such as Plenary Assembly, Secretariat, etc. Future editions of this Recommendation will contain the proper terminology related to the new ITU structure.

2 In this Recommendation, the expression "Administration" is used for conciseness to indicate both a telecommunication administration and a recognized operating agency.

© ITU 1994

All rights reserved. No part of this publication may be reproduced or utilized in any form or by any means, electronic or mechanical, including photocopying and microfilm, without permission in writing from the ITU.

ABSTRACT

This Recommendation provides definitions applicable to the maintenance of international sound-programme and television-sound transmissions, illustrated as required, and has an appendix on level, loss and noise units.

KEY WORDS

db designations, definitions, level, loss and noise units, sound-programme, television-sound, vocabulary.

Recommendation N.1

DEFINITIONS FOR APPLICATION TO INTERNATIONAL SOUND-PROGRAMME AND TELEVISION-SOUND TRANSMISSION^{1), 2)}

(Published in 1964; Revised in 1968, 1972, 1976, 1980, 1988 and 1993)

Abbreviations

For the purpose of this Recommendation, the following abbreviations apply:

ISPC	International Sound-Programme Centre
NSPC	National Sound-Programme Centre
PML	Permitted Maximum Level

The following definitions apply to the maintenance of international sound-programme transmissions. Other definitions are used for other purposes, e.g. an international sound-programme link and international multiple destination sound-programme link as defined in clauses 11 and 12 respectively below, are within the definition of an international sound-programme circuit as defined by the CMTT.

NOTES

1 It is intended that the definitions given in this Recommendation and Recommendation N.51 [7] should remain identical, so far as is practical, by use of only simultaneous amendments.

2 A sound-programme circuit section, circuit, link or connection is considered to be permanent for maintenance purposes if it is always available for use when required, whether or not it is continuously in use. Such a circuit may be used for the purposes of occasional transmission, that is, transmissions of short duration, e.g. less than 24 hours, or it may be used for a long duration, i.e. one day or more. A permanent sound-programme connection between broadcasting organizations' premises may be used at any time, except only for periods of maintenance as agreed between the Administrations and broadcasting organizations concerned.

A sound-programme circuit section, circuit, link or connection is considered to be temporary for maintenance purposes when it has no existence outside the period of transmission (including line-up and testing time) for which it is required.

1 international sound-programme transmission: The transmission of sound signals over the international telecommunication network for the purpose of interchanging sound-programme material between broadcasting organizations in different countries.

2 broadcasting organization: A broadcasting organization is an organization which is concerned with either or both sound and television broadcasting. Most of the customers ordering facilities for sound-programme and television transmission are broadcasting organizations. For convenience, the term broadcasting organization is used to denote the activity of any user or customer and, where so used, it is equally applicable to any other customer requiring sound-programme or television transmissions.

3 broadcasting organization (send): The broadcasting organization at the sending end of an international sound-programme transmission.

4 broadcasting organization (receive): The broadcasting organization at the receiving end of an international sound-programme transmission.

5 international sound-programme centre (ISPC): A centre at which at least one international sound-programme circuit (see clause 9) terminates and in which international sound-programme connections (see clause 13) can be made up by the interconnection of international and national sound-programme circuits.

The responsibility of an ISPC is given in Recommendation N.5 [8].

6 national sound-programme centre (NSPC): A centre at which two or more national sound-programme circuits terminate and at which national sound-programme circuits may be interconnected.

1) Definitions in this Recommendation apply both to analogue and digital systems.

2) Annex A gives definitions and designations for units of measurements for sound-programme and television-sound transmission.

7 sound-programme circuit section: The unidirectional national or international sound-programme transmission path between two stations at which the programme is accessible at audio frequencies. The transmission path may be established via terrestrial or single destination satellite routing. (See Note 2 above and Figures 1 and 3.)

8 international multiple destination sound-programme circuit section: The unidirectional sound-programme transmission path from one frontier station to two or more of the frontier stations at which interconnection is made at audio frequencies. (See Note 2 above and Figure 4.)

9 international sound-programme circuit: The transmission path between two ISPCs which comprises one or more sound-programme circuit sections (national or international), together with any necessary audio equipment. The transmission path may be established via terrestrial or single destination satellite routing. (See Note 2 above and Figures 1 and 3.)

10 international multiple destination sound-programme circuit: The unidirectional transmission path from one ISPC to two or more other ISPCs comprising sound-programme circuit sections (national or international) one of which is an international multiple destination circuit section, together with any necessary audio equipment. (See Note 2 above and Figure 4.)

11 international sound-programme link: The unidirectional transmission path between the ISPCs of the two terminal countries involved in an international sound-programme transmission. The international sound-programme link comprises one or more international sound-programme circuits (see Figures 1 and 3 below) interconnected at intermediate ISPCs. It can also include national sound-programme circuits in transit countries. (See Note 2 above and Figure 2.)

12 international multiple destination sound-programme link: The unidirectional transmission path between the ISPCs of the terminal countries involved in an international multiple destination sound-programme transmission. The international multiple destination sound-programme link comprises international sound-programme circuits, one of which is an international multiple destination sound-programme circuit. (See Note 2 above and Figure 5.)

13 international sound-programme connection: The unidirectional transmission path between the broadcasting organization (send) and the broadcasting organization (receive) comprising the international sound-programme link extended at its two ends over national sound-programme circuits to the broadcasting organization. (See Note 2 above and Figure 2.)

14 international multiple destination sound-programme connection: The unidirectional transmission path between the broadcasting organization (send) and two or more broadcasting organizations (receive) comprising the international multiple destination sound-programme link extended at its ends over national sound-programme circuits to the broadcasting organizations. (See Note 2 above and Figure 5.)

15 send reference station: The transmit sub-control station of an international multiple destination sound-programme circuit section (see clause 8), circuit (see clause 10) or link (see clause 12). (See Figures 4 and 5.)

16 effectively transmitted signals in sound-programme transmission: For sound-programme transmission, a signal at a particular frequency is said to be effectively transmitted if the nominal overall loss at that frequency does not exceed the nominal overall loss at 1020 Hz by more than 4.3 dB. This should not be confused with the analogous definition concerning telephone circuits given in the Recommendation G.151 [1].

For sound-programme circuits, the overall loss (relative to that at 1020 Hz) defining effectively transmitted frequency is 1.4 dB, i.e. about one third of the allowance.

17 types of sound-programme circuit³⁾: The various types of international sound-programme circuit or sections of such circuits should be referred to by quoting the top nominal frequency, in kHz, effectively transmitted.

Example: 10-kHz sound-programme circuit.

³⁾ To reduce problems in ordering and charging for sound-programme circuits, Study Group II has a classification of circuits based on their approximate bandwidth (see the Recommendation cited in Recommendation D.180 [2]).

18 international television-sound transmission: The transmission of television-sound signals over the international telecommunications network for the purpose of interchanging television-sound material between broadcasting organizations in different countries.

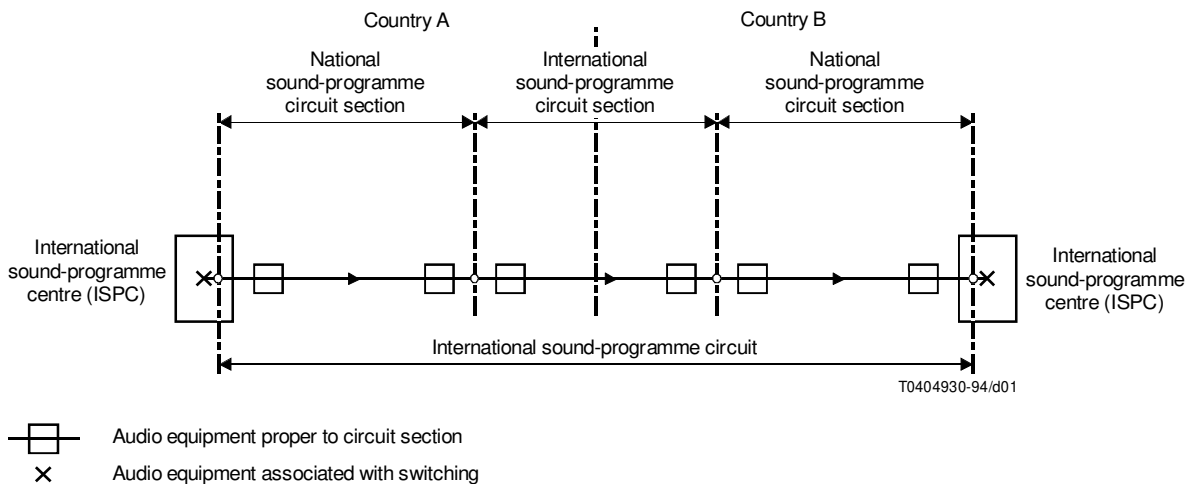

FIGURE 1/N.1

An international sound-programme circuit composed of two national and one international sound-programme circuit sections

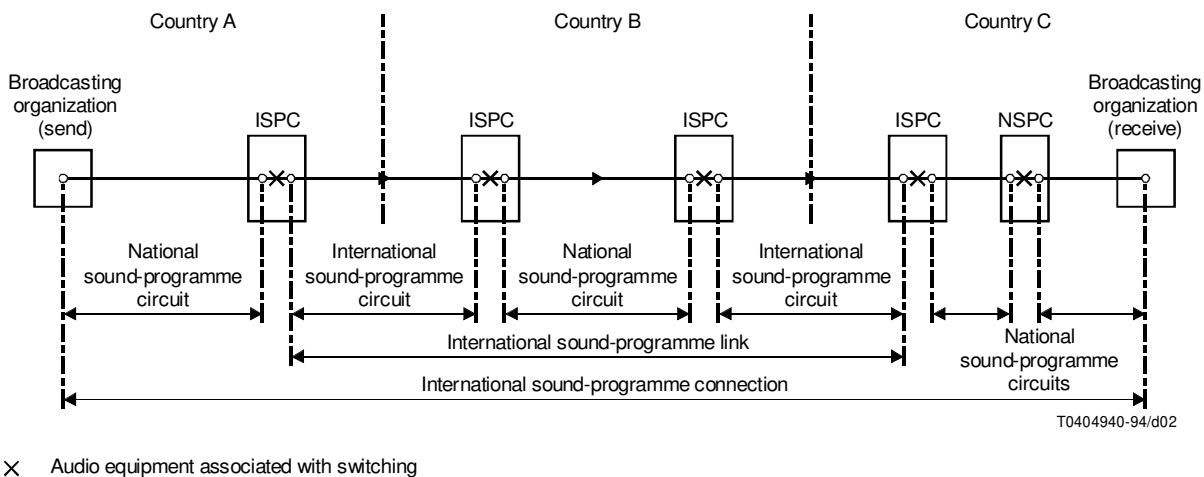

FIGURE 2/N.1

An international sound-programme link composed of international and national sound-programme circuits and extended on a national sound-programme circuit at each end to form an international sound-programme connection

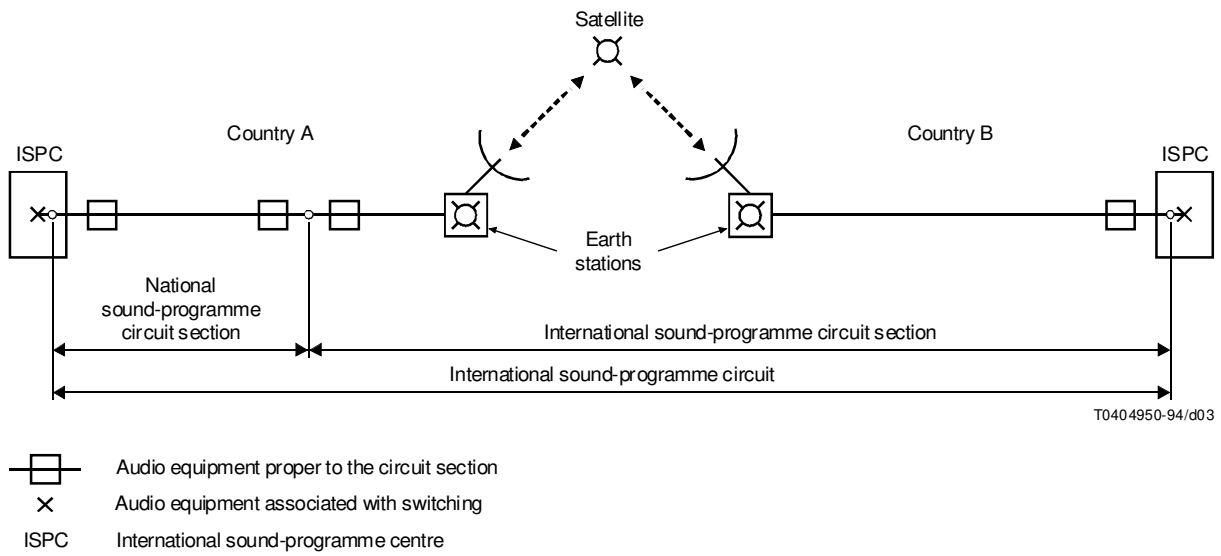
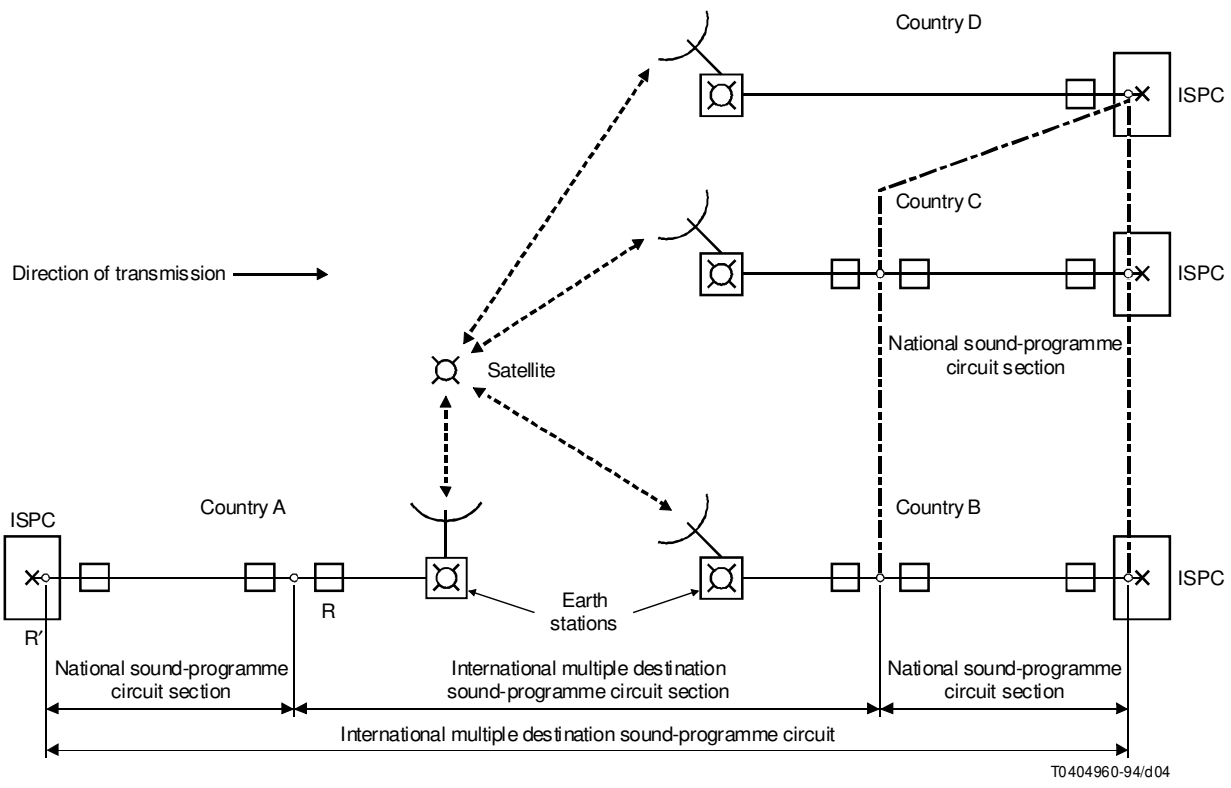
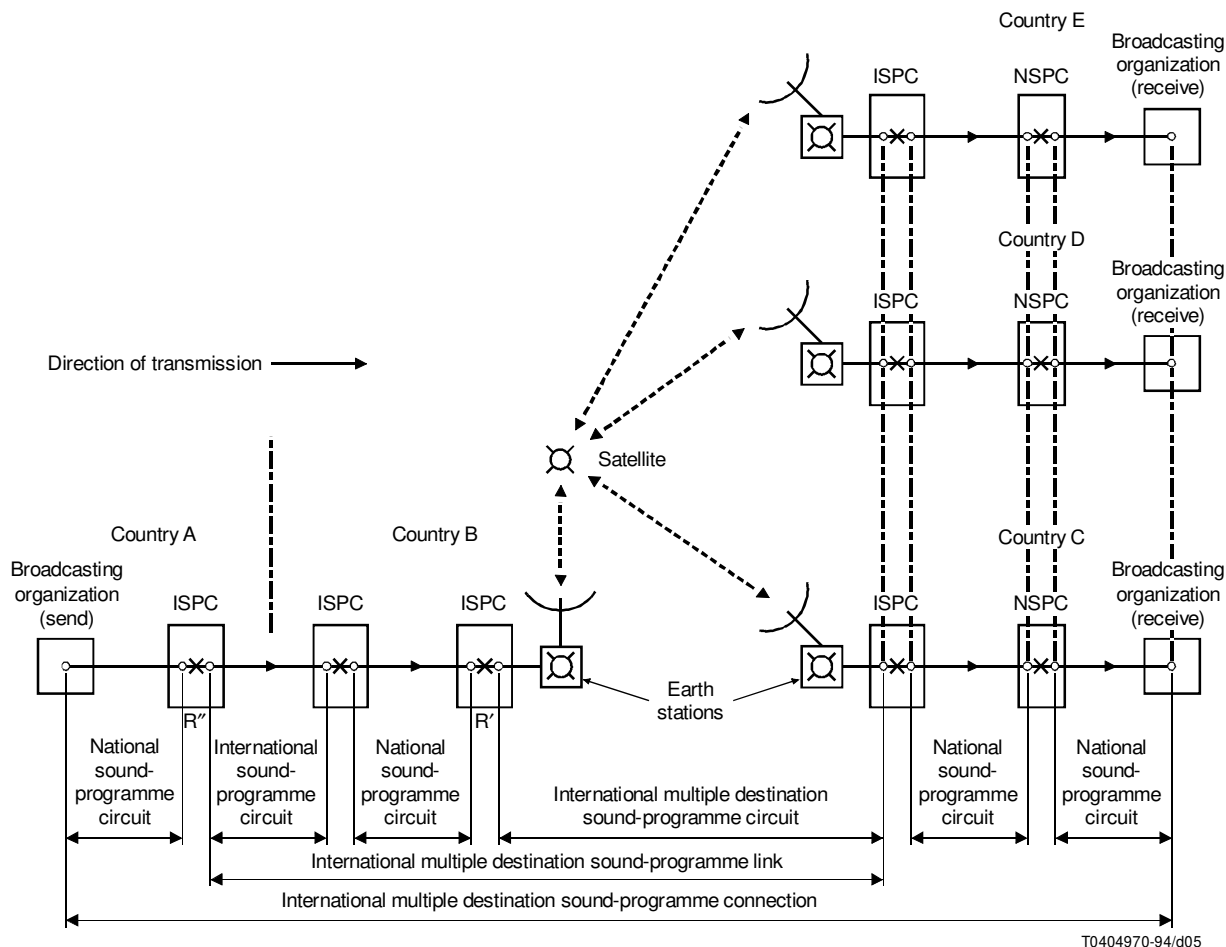

FIGURE 3/N.1
**Single-destination international sound-programme circuit
 routed via a communication satellite system**



- Audio equipment proper to a circuit section
- × Audio equipment associated with switching
- ISPC International sound-programme centre
- R *Send reference* station for the multiple destination international sound-programme circuit section
- R' *Send reference* station for the multiple destination international sound-programme circuit

FIGURE 4/N.1
**International multiple destination sound-programme circuit
 routed via a communication satellite system**



- R' *Send reference station for international multiple destination sound-programme circuit*
- R'' *Send reference station for international multiple destination sound-programme link*
- ISPC International sound-programme centre
- NSPC National sound-programme centre
- X Audio equipment associated with switching

FIGURE 5/N.1
**International multiple destination sound-programme link extended to form
a connection routed via a communication satellite system**

Annex A

Definition and designations for level, loss and noise units used for sound-programme and television-sound transmission

(This annex forms an integral part of this Recommendation)

A.1 dB-unit designations in N-Series Recommendations

This annex gives the dB unit designations of logarithmic quantities used for sound-programme and television-sound transmission in N-Series Recommendations. The annex is in line with Recommendation B.12 [3] and CCIR Recommendation 574 [4].

A.2 Unit designations used

A.2.1 absolute power (dBm) and absolute voltage (dBu) levels: The unit designation dBm applies to the absolute power level when the reference power is 1 mW. The unit designation dBu applies to the absolute voltage level when the reference voltage is 0.775 V. The general relation between absolute power level (L_m) and absolute voltage level (L_u) is given by:

$$L_m = L_u - L_z$$

where

$$L_z = 10 \log_{10} \frac{Z}{Z_0} \quad \text{dBm}$$

which is the so-called impedance correction term; where $Z_0 = 1000$ ohms reference impedance and $Z =$ impedance of the circuit under test.

Absolute voltage levels, for which terminal impedance is not defined, are more rarely used. As a correction, power level may be calculated for impedances other than 600 ohms, with respect to 1 mW.

The power level thus calculated would be equal to that measured in a correctly terminated system.

A.2.2 relative power (dBr) and relative voltage (dBur) levels: The relative power level of a point in a transmission system, where the transmission plan is based on power, is the nominal power gain at the reference frequency from a reference point to the point considered. Values of the relative power level are usually characterized by the unit designation dBr.

The relative voltage level in a transmission system, where the transmission plan is based on voltage, is the nominal voltage gain at the reference frequency from a reference point to the point considered. Values of the relative voltage level are usually characterized by the unit designation dBur.

For sound-programme circuits, the zero relative level point is the origin of the sound programme connection as defined in Recommendation J.14 [5].

A.2.3 power level referred to a zero relative level point (dBm0) and voltage level referred to a zero relative level point (dBu0): The power level referred to a point of zero relative level point is provisionally called "load level" (L_{m0}). The load level with respect to 1 mW is the absolute power level (L_m) with respect to 1 mW minus the relative power level (L_r):

$$L_{m0} = L_m - L_r$$

The voltage level with respect to 0.775 V referred to a zero relative level point (L_{u0}) is the absolute voltage level with respect to 0.775 V (L_u) minus the relative voltage level (L_{ur}):

$$L_{u0} = L_u - L_{ur}$$

For a given signal within a given transmission system a level referred to a zero relative level point is the same along a transmission line.

A.2.4 Designation of weighted noise measurement units

For noise measurements made with a weighting filter a “p”⁴⁾ is added to the unit designation, e.g. dBm0p and dBmp. Unlike telephony, “p” for sound-programme does not identify the type of weighting filter that has been used.

A.2.5 Designation of quasi-peak noise measurement units

For noise voltage level measurements (reference voltage: 0.775 V) made with a quasi-peak instrument (in accordance with CCIR Recommendation 468 [6]) instead of an instrument showing r.m.s.-values, the letter “q” is used similarly to the letter “m”, e.g. dBq0ps.

A.2.6 Designation of sound-programme transmission units

Unit designations associated with sound-programme transmission contain a supplementary “s” (s for sound), e.g. dBrs, dBm0s, dBm0ps and dBq0ps. The “s” indicates that the bandwidth used in the measurement is related to sound-programme transmission so as to prevent confusion when differing measurement techniques, weighting filters or meters are used.

A.3 Practical problems

There is a wide range of measuring instruments used at different measurement points, so that differences are always bound to appear. A state which every Administration is prepared to define is the permitted maximum level (PML). Despite different relative power levels, depending on the systems, a direct relation can now be indicated between the value of the level to be measured and the PML. If, for instance, a signal of 21 dB below the PML is sent as a measurement signal, it must also be received as a signal 21 dB below PML, independently of local relative levels, which may differ according to systems and Administrations.

References

- [1] CCITT Recommendation *General performance objectives applicable to all modern international circuits and national extension circuits*, Rec. G.151 (Note 1, clause 1).
- [2] CCITT Recommendation *Occasional provision of circuits for International sound- and television-programme transmissions*, Rec. D.180 (clause 3).
- [3] CCITT Recommendation *Use of the decibel and neper in telecommunications*, Rec. B.12.
- [4] CCIR Recommendation *Use of the decibel and neper in telecommunications*, Rec. 574.
- [5] CCITT Recommendation *Relative levels and impedances on an international sound-programme connection*, Rec. J.14.
- [6] CCIR Recommendation *Measurement of audio-frequency noise voltage level in sound broadcasting*, Rec. 468.
- [7] CCITT Recommendation *Definitions for application to international television transmissions*, Rec. N.51.
- [8] CCITT Recommendation *Sound-programme control, sub-control and send reference stations*, Rec. N.5.

⁴⁾ p for “pondéré” = weighted.