



INTERNATIONAL TELECOMMUNICATION UNION

# CCITT

THE INTERNATIONAL  
TELEGRAPH AND TELEPHONE  
CONSULTATIVE COMMITTEE

**M.20**

(10/92)

**MAINTENANCE: INTRODUCTION  
AND GENERAL PRINCIPLES**

---

**MAINTENANCE PHILOSOPHY FOR  
TELECOMMUNICATION NETWORKS**



**Recommendation M.20**

---

## FOREWORD

The CCITT (the International Telegraph and Telephone Consultative Committee) is a permanent organ of the International Telecommunication Union (ITU). CCITT is responsible for studying technical, operating and tariff questions and issuing Recommendations on them with a view to standardizing telecommunications on a worldwide basis.

The Plenary Assembly of CCITT which meets every four years, establishes the topics for study and approves Recommendations prepared by its Study Groups. The approval of Recommendations by the members of CCITT between Plenary Assemblies is covered by the procedure laid down in CCITT Resolution No. 2 (Melbourne, 1988).

Recommendation M.20 was revised by Study Group IV and was approved under the Resolution No. 2 procedure on the 5th of October 1992.

---

## CCITT NOTES

- 1) In this Recommendation, the expression "Administration" is used for conciseness to indicate both a telecommunication administration and a recognized private operating agency.
- 2) A list of abbreviations used in this Recommendation can be found in Annex A.

© ITU 1993

All rights reserved. No part of this publication may be reproduced or utilized in any form or by any means, electronic or mechanical, including photocopying and microfilm, without permission in writing from the ITU.

## Recommendation M.20

### MAINTENANCE PHILOSOPHY FOR TELECOMMUNICATIONS NETWORKS<sup>1)</sup>

(revised 1992)

#### *Abstract*

This Recommendation describes maintenance philosophy for telecommunications networks. It also defines network maintenance phases, network supervision capabilities, and bringing into service requirements.

#### *Keywords*

- maintenance,
- maintenance entity,
- network.

## **1 General**

1.1 Maintenance involves the whole of operations required for setting up and maintaining, within prescribed limits, any element entering into the setting-up of a connection (see Recommendation M.60)<sup>2)</sup>. In order to properly plan and program the maintenance operations required to establish and maintain an analogue, digital or mixed network, the following general strategy is recommended.

1.1.1 A maintenance organization should be established using the guiding principles set forth in Recommendations M.70 [11] and M.710 [12] for automatic circuits switched over analogue, digital and mixed networks. In addition, the concept of control and subcontrol stations found in Recommendations M.80 [13] and M.90 [14] for international circuits and transmission systems should be implemented.

1.1.2 The strategy should include the following maintenance operations considerations:

- a) It should consider the evolution of the network from the present highly analogue environment to the future almost wholly digital environment. In doing this, it must consider the new services and functions offered by the networks (e.g. CCITT Signalling System No. 7 and ISDN) and the maintenance tools and capabilities becoming available (e.g. performance monitoring).
- b) It should employ an overall maintenance philosophy that uses the maintenance entity concept, failure classification and network supervision process specified in § 3.
- c) It should provide for the maintenance of the network systems, equipment and circuits during the following activities:
  - installation and acceptance testing (§ 4);
  - bringing into service (§ 4);
  - keeping the network operational (§ 5).
- d) It should support other maintenance activities (§ 6) associated with the administration of maintenance operations (e.g. data bases, spare parts, failure statistics, etc.) along with a detailed plan for preventive maintenance, where required, on the various telecommunication equipments (hardware and software).

---

<sup>1)</sup> The principles described in Recommendation M.21 [15] should also be taken into account.

<sup>2)</sup> It is recognized that for some Administrations, bringing into service is not considered to be part of maintenance.

- e) It should have as a major aim to minimize both the occurrence and the impact of failures and to ensure that in cause of failure:
- the right personnel can be sent to;
  - the right place with;
  - the right equipment;
  - the right information at;
  - the right time to perform;
  - the right actions; and
  - the right notification.

1.2 To apply this general strategy in a network, the following principles can be used:

*Preventive maintenance*

The maintenance carried out at predetermined intervals or according to prescribed criteria and intended to reduce the probability of failure or the degradation of the functioning of an item.

*Corrective maintenance*

The maintenance carried out after fault recognition and intended to restore an item to a state in which it can perform a required function.

*Controlled maintenance*

A method of sustaining a desired technical performance by the systematic application of supervision, testing and performance sampling in order to minimize preventive maintenance and to reduce corrective maintenance.

1.3 In general for all three types of network (analogue, digital and mixed), the use of controlled maintenance principles is recommended, i.e., the maintenance actions are determined on the basis of information generated in the maintained system or coming from auxiliary supervision systems.

1.4 The advantages of the controlled maintenance approach are that it directs future maintenance activity to those areas where a known improvement in service to the customer will be achieved. The monitoring techniques which are inherent in controlled maintenance provide data which simplify the identification of hidden faults by using statistical analysis.

1.5 The smaller the portion of the network which is affected by a failure, the more difficult and/or less economic it may be to detect it using controlled maintenance techniques. In these cases corrective and/or preventive maintenance techniques may have to be employed.

1.6 In analogue and mixed networks a mixture of the above-mentioned principles are used, depending on the existing equipment included in the network (see Recommendations M.710, M.715 to M.725).

1.7 The maintenance philosophy and fundamental principles are closely linked to

- availability performance;
- network technical performance;
- network economics.

## **2 Maintenance objectives**

### *Purpose*

The main purpose of a general maintenance philosophy for analogue, digital and mixed networks is to accomplish the aims defined in § 1.1.

In addition the following objectives should be fulfilled:

- for a defined level of service the total cost should be kept to a minimum by the use of appropriate methods (e.g. centralized operation and maintenance);
- the same maintenance philosophy should be applied to exchanges, transmission equipment, data equipment, subscriber terminals, etc., wherever possible.

## 2.2 Economics

New technology provides new possibilities for low cost maintenance not only for individual exchanges, but for the whole network.

The operation and maintenance functions in a network should be planned in such a way that the life cost will be a minimum. For a defined level of service the total cost consists of

- investment cost;
- operations cost;
- maintenance cost;
- cost for loss of traffic.

## 2.3 *Transition from analogue to digital networks including ISDNs*

The basic philosophy, as described in this Recommendation, is valid in principle for analogue, mixed and digital networks. However, many digital network parts are more suited to the implementation of controlled maintenance than are analogue network parts. Due to new technological developments, maintenance functions can be incorporated within digital equipment. Analogue equipment often requires additional external maintenance systems in order to permit controlled maintenance, e.g. ATME No. 2 (see Recommendation O.22 [1]).

## 2.4 *Centralized maintenance operations*

The introduction of digital telecommunications equipment with enhanced maintenance operations functions, including the facility for remote reporting and control, provides new opportunities for centralization. Supplement No. 6.2 [2] provides a description of a centralized maintenance organization. There are many benefits that can be gained from centralization. These include the ability to

- be more flexible in the organization of maintenance operations and administration;
- utilize highly skilled human resources more efficiently;
- utilize more effectively data and data bases;
- improve maintenance effectiveness;
- decrease maintenance costs;
- increase the availability of transmission and switching systems;
- improve quality of service.

*Note* – By the use of remote terminals, an Administration can choose how they allocate their technical staff between local and centralized locations.

Because of these benefits, it is recommended that centralized maintenance and other operations capabilities be considered when specifying new telecommunications systems and equipment. The general principles for setting-up, operating and maintaining a Telecommunication Management Network (TMN) to support centralized maintenance and other operations are given in Recommendation M.3010 [16].

In addition, the introduction of open or standardized interfaces between Network Elements (NEs) and Operations Systems (OS) via TMN, including interfaces between TMNs will allow for enhancing maintenance, operations and testing procedures. These new enhanced procedures will be based upon remote capabilities to perform the following:

- loopbacks;
- access to performance and test data;
- status change and control;
- switchovers;
- others.

### 3 Overall maintenance philosophy

#### 3.1 Network components for maintenance

##### 3.1.1 Maintenance entity concepts

In order to facilitate efficient maintenance, the telecommunication network (analogue and digital) is divided into parts called Maintenance Entities (MEs), Maintenance Entity Assemblies (MEAs) and Maintenance Sub-Entities (MSEs). Examples of MEs, MEAs and MSEs are given in Figures 1/M.20, 2/M.20 and 3/M.20.

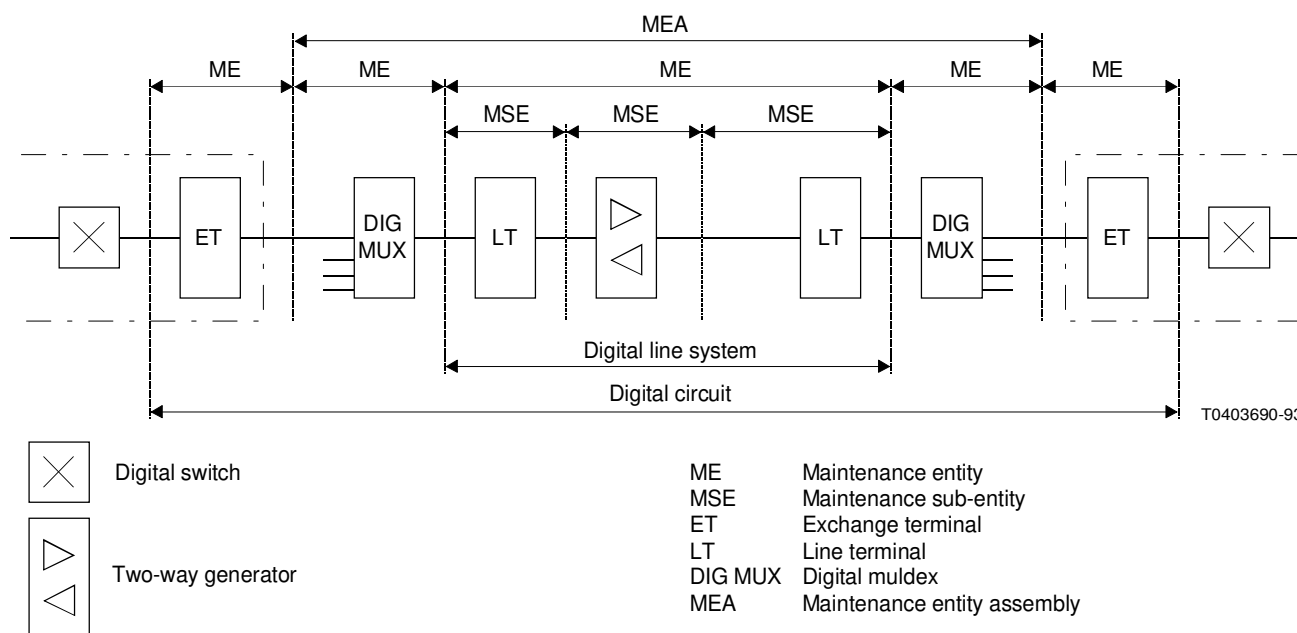

FIGURE 1/M.20

Maintenance entity concept for digital transmission networks

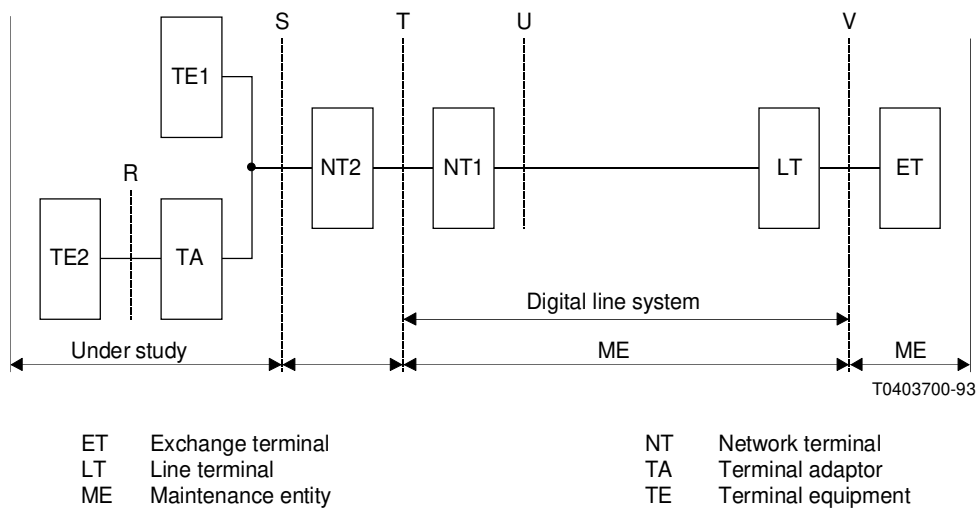

FIGURE 2/M.20  
 Maintenance entity concept for the ISDN subscriber network

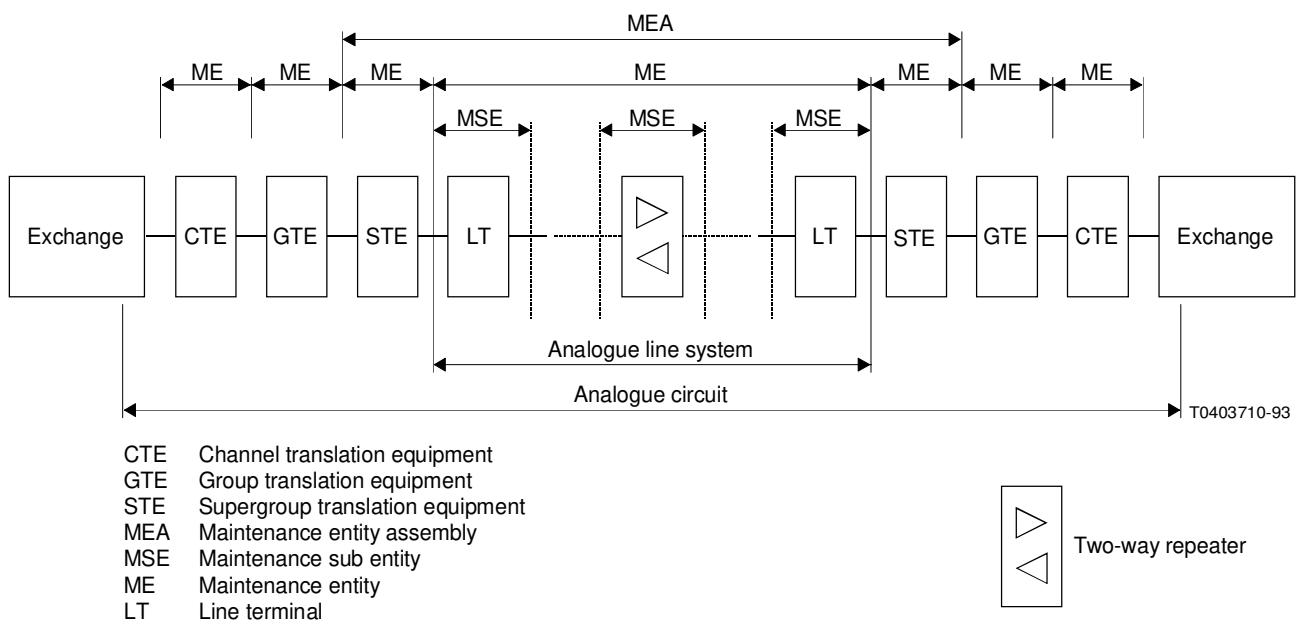

FIGURE 3/M.20  
 Maintenance entity concept for analogue networks

3.1.1.1 *Definition of Maintenance Entity*

Maintenance entities are defined by the following requirements:

- The different equipment of a telecommunications network constituting the MEs are interconnected at consecutive and easily identifiable interface points.<sup>3)</sup> At these points the interface conditions defined for these equipment apply and they possess the means of detecting maintenance events and the means of restoration.
- If the telecommunication equipment supports bidirectional transmission, it normally consists of telecommunications equipment transmitting in both directions and then both directions are considered part of the same ME.
- When a failure occurs within a network, it is desirable that the maintenance alarm indication appears at the failed maintenance entity. When this is not practical, the indication should appear at the closest possible entity.
- Maintenance alarm information indications in an entity should not cause related alarm information indications at other entities. In the event that such indications are permitted to occur, they should clearly indicate that the failure has occurred upstream, and not in the other entities displaying the information.

Meeting these four requirements ensures that the responsible maintenance personnel are called into action, and that usually no unnecessary maintenance activity is initiated elsewhere.

In a digital network, for example, easily identifiable points may be provided by digital distribution frames. Even in a location where no digital distribution frame is provided, an equivalent point, where defined interface conditions apply, will normally be identifiable. The interface between the exchange terminals and the digital switch may be accessed on a virtual basis.

3.1.1.2 *Maintenance Entity interface*

An ME has to perform a determined function between telecommunication interfaces (see Figure 4/M.20). The performance is checked by internal failure detection and conveyed to the maintenance interface either automatically after a failure occurrence, or after a request for maintenance information.

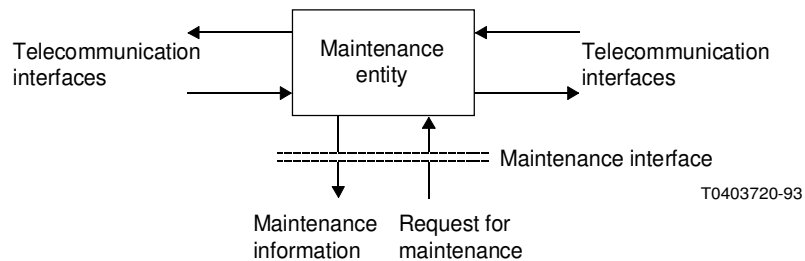

FIGURE 4/M.20  
**Maintenance entity interface**

In addition, other operations and administrative functions may be carried out by the maintenance interface. Several types of maintenance interfaces are described in Recommendation M.3010 [16] which covers the TMN.

<sup>3)</sup> If an easily identifiable interface point is not available, the interface point may be replaced by a point permitting sectionalization with functions such as, e.g. looping-back or performance monitoring.



### 3.1.1.3 *Definition of Maintenance Entity Assembly*

A maintenance entity assembly (MEA) is defined by the following requirements:

- an MEA contains a group of MEs assembled for additional maintenance purposes;
- requirements that apply for MEs apply as well for MEAs;
- an MEA may detect failures and maintenance event information which can not be detected by MEs;
- an MEA may provide end-to-end maintenance alarm information which can not be provided by MEs.

End-to-end information may be collected by using additional supervision means.

### 3.1.1.4 *Definition of Maintenance Sub-Entity (MSE)*

A maintenance sub-entity is defined by the following principles:

- the different parts of an MSE constituting the MEs are interconnected at consecutive and easily identifiable interface points;
- when a failure occurs within an MSE, it is desirable that the maintenance alarm information indication appears at the failed maintenance entity containing the MSE;
- a failed MSE should be identified as failed by the fault location process, but should lead only to the identification of the failed ME by the supervision process;
- an MSE generally corresponds to the item which is replaceable during routine operations in the event of a failure.

### 3.1.1.5 *Maintenance Entity choices*

The choice of ME, MEA and MSE should be compatible with the maintenance organization of an Administration (Recommendations M.710 to M.725 [12]).

### 3.1.2 *Support Entity concept*

The Support Entity functions (SEF) are fault localization, billing, protection switching, etc. They are not directly involved in the telecommunication process. A Support Entity (SE) can contain one or more SEFs.

### 3.1.3 *Network Element concept*

The Network Element (NE) and the Network Element function (NEF) are defined in Recommendation M.3010 [16]. Essentially an NE is telecommunication equipment which may have associated or built-in capability for surveillance, reporting and/or control.

### 3.1.4 *Relationship between Maintenance Entities, Support Entities and Network Elements*

Examples of parts of network elements and an example of digital switch with billing equipment are given in Figures 5/M.20 and 6/M.20.

## 3.2 *Failure concepts*

The following definitions and classifications are used in developing the concept of a failure.

### 3.2.1 *Anomalies*

An anomaly is a discrepancy between the actual and desired characteristics of an item.

The desired characteristic may be expressed in the form of a specification.

An anomaly may or may not affect the ability of an item to perform a required function.

As an example, for a multiplexer one type of elementary information that can be detected is an error in the frame alignment word. This elementary information is an anomaly. More examples of anomalies are given in Recommendation M.2100 [17].

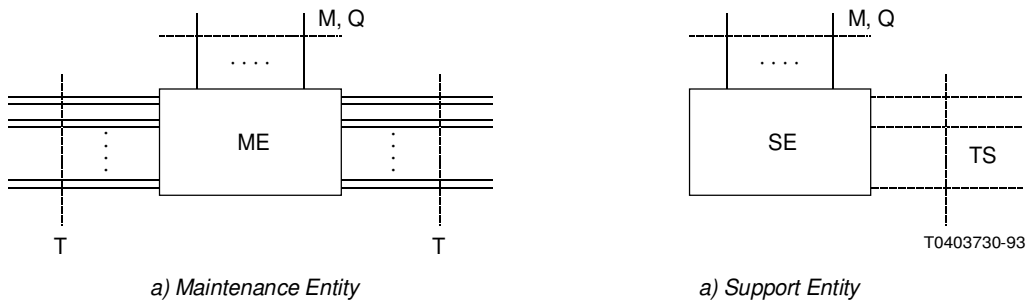

- T Telecommunications interface
- Q Q<sub>x</sub>, Q<sub>3</sub>, interfaces
- M (Non-standardized) maintenance interface
- TS Telecommunications support interface

FIGURE 5/M.20  
Parts of network elements

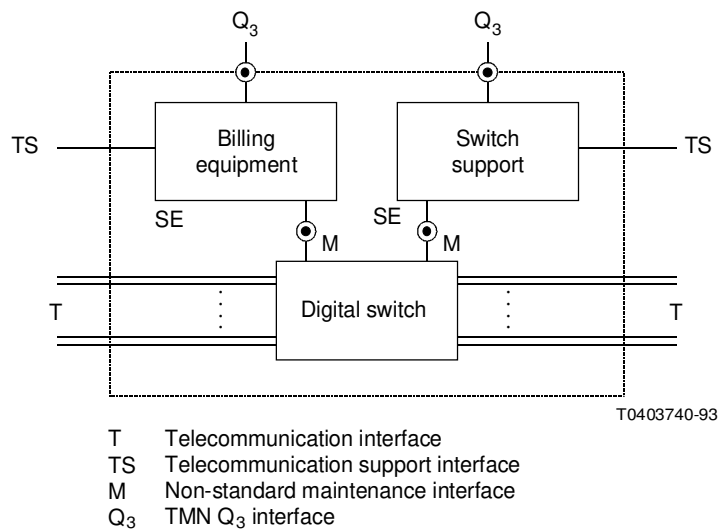

- T Telecommunication interface
- TS Telecommunication support interface
- M Non-standard maintenance interface
- Q<sub>3</sub> TMN Q<sub>3</sub> interface

FIGURE 6/M.20  
Example of Network Elements (NE)

### 3.2.2 Defects

A defect is a limited interruption in the ability of an item to perform a required function. It may or may not lead to maintenance action depending on the results of additional analysis.

Successive anomalies causing a decrease in the ability of an item to perform a required function are considered as a defect.

As an example, the G.700-Series Recommendations [3] recommends that three consecutive errored frame alignment words will give a loss of frame alignment. This loss of frame alignment is a defect. More examples of defects are given in Recommendation M.2100 [17].

The process of using anomalies and defects is explained in § 3.3.

### 3.2.3 *Failures*

A failure is the termination of the ability of an item to perform a required function.

*Note* – After failure, the item has a fault.

Analysis of successive anomalies or defects affecting the same item can lead to the item being considered as “failed”.

#### 3.2.3.1 *Classification of failures*

The severity of the failure depends on the failure effect. This effect can be related to

- the network service performance requirements as experienced by the subscribers;
- the probability that multiple failures will occur, thus resulting in a deteriorating performance as seen by the customer;
- the probable loss of revenue to the Administration.

The failures can be classified according to their importance and consequences to the quality of service provided to the subscribers and to the network technical performance:

- Failures which result in complete interruption of service(s) for one or several subscribers.
- Failures which result in degradation of service(s) (e.g. degradation of transmission quality) to one or several subscribers.
- Failures which decrease the availability performance of the equipment and/or the network but do not affect the subscribers.
- Failures can result in either a permanent or intermittent conditions.
- The severity of a failure can be determined by measuring the down time, up time and failure rate of the ME. These items are defined in Supplement No. 6 to Fascicle II.3 [4].

### 3.2.4 *Fault*

A fault is the inability of an item to perform a required function, excluding that inability due to preventive maintenance, lack of external resources or planned actions.

*Note* – A fault is often the result of a failure of the item itself, but may exist without prior failure.

## 3.3 *Network supervision*

Network supervision is a process in which the anomalies and defects detected by the maintenance entities ME or MEA are analysed and checked. This analysis may be internal or external to the entity. In the external case it can be accomplished either locally or on a centralized basis.

For maintenance, this supervision process has to include the following actions:

- a) Locating “failed” equipment, or the equipment in which a fault is suspected or a failure is believed to be imminent. It is generally carried out by analytical or statistical identification processes. The supervision process consists of three continuously running concurrent processes
  - the supervisory process for anomalies (short period);
  - the defect supervisory process (medium period); and
  - the malfunction supervisory process (long period).

Each process is interfaced by the characteristic data, e.g. accumulated anomaly data and accumulated defect data. The supervisory processes for anomalies and defects respectively, indicate that the anomaly or defect states have been reached. The malfunction supervisory process evaluates the performance level of the maintenance entity and judges it to be normal, degraded or unacceptable. These levels are determined from the anomalies and defects received and analyzed over a given time. The thresholds

limiting degraded or unacceptable performance limits and the process period are defined for each defect and confirmed fault or group of anomalies and defects and also for each type of entity. Indications of degraded and unacceptable performance levels are generated each time the corresponding threshold is exceeded. This process is shown in Figure 7/M.20.

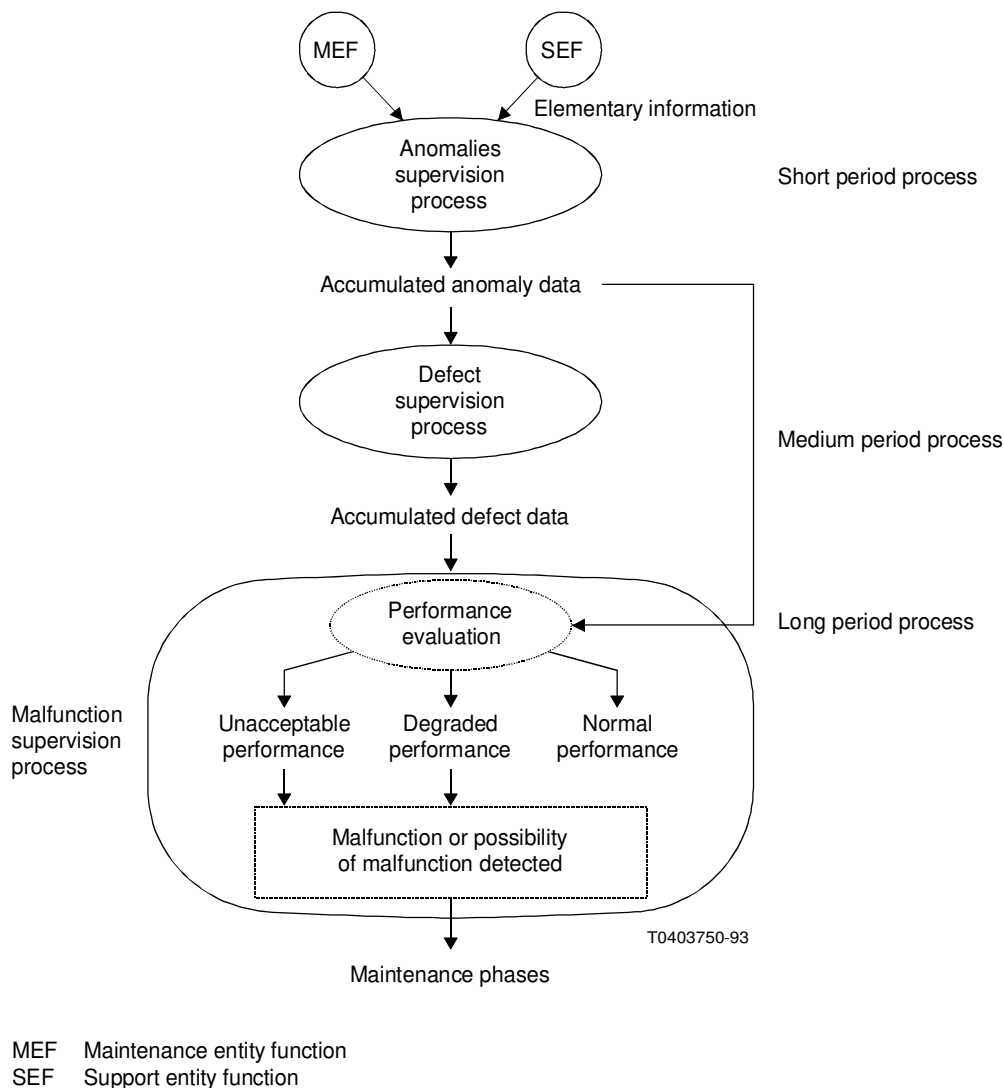

FIGURE 7/M.20  
Supervision process for a maintenance entity

- b) Reporting of failures and faults to maintenance personnel.
- c) Transmission of data to the maintenance personnel, relating to specific functional features of the network (traffic, state of equipment, particular malfunctions, etc.). This information can be transmitted systematically or on demand.
- d) Protecting the system by transmitting to all network equipment involved, the necessary information for automatic initialization of internal or external restoration mechanisms, e.g. reconfiguration, traffic rerouting, etc.
- e) Modify the supervision process due to
  - the type of service being offered over a given portion of the network;
  - the time of day.

## 4 Bringing-into-service new international transmission systems and circuits

### 4.1 *Installation and acceptance testing*<sup>4)</sup>

For new systems, this work may include the necessary installation of new equipment. Once the new equipment is working, the Administration should make the necessary tests to ensure the new system meets required specifications. Acceptance testing of the new system or equipment should be based on policies established by the Administration. However, Administrations may wish to use the performance monitoring techniques found in Recommendation M.34 [18] to aid in their acceptance testing of new transmission systems.

### 4.2 *Setting-up and lining-up*

As soon as Administrations have decided to bring a new international transmission system and/or circuit into service, the necessary contacts are made between their technical service for the exchange of information. Those services jointly select the control and sub-control stations for the new system or circuit (see Recommendations M.80 [13] and M.90 [14]).

The technical service of each Administration is responsible for the setting-up and lining-up of the line on circuit sections in its territory, and for arranging that the adjustments and tests required are made by the station staff concerned.

### 4.3 *Detailed considerations*

To set-up a line section or circuit which crosses a frontier, Administrations should arrive at bilateral agreements on the basis of CCITT Recommendations and, for radio-relay sections, the Recommendations of the CCIR. Administrations should refer to the following Recommendations for detailed considerations associated with bringing-into-service the following entities:

#### 4.3.1 *New transmission systems*

Recommendations M.450 to M.475 [19] and M.34 [18].

#### 4.3.2 *Telephone circuits*

Recommendations M.570 to M.590 [20].

#### 4.3.3 *Common channel signalling systems*

Recommendations M.4030 [21] and M.4100 [24].

#### 4.3.4 *Leased and special circuits*

Recommendations M.1000-Series [26].

#### 4.3.5 *International digital paths, sections and line sections*

Recommendations M.2100 [17] and M.2110 [23].

### 4.4 *Other considerations*

After the control station has determined from reports provided by the subcontrol station that appropriate tests and adjustments have been performed, the control station conducts overall tests of the system or circuit. The overall tests results are recorded, operations systems data bases are updated and synchronized between Administrations, and the system and/or circuits are placed in service. At this time the system and/or circuits are transferred to a performance measuring state (see § 5.1) to track and ensure their continuing proper operation.

---

<sup>4)</sup> Installation and acceptance testing is generally not considered part of maintenance.

## 5 Maintenance phases under normal and fault conditions

Under normal conditions in the network, performance information should be gathered from MEs on a continuous or periodic basis. This data can be used to detect acute fault conditions which generate alarm reports. Further analysis may reveal subtle degradations which generate maintenance information reports.

After the occurrence of a failure in the network, a number of maintenance phases are required to correct the fault and to protect, when possible, the traffic affected by the fault if it has been interrupted.

As an example, Figure 8/M.20 lists the maintenance phases which are involved before and after a failure occurrence in a maintenance entity (ME). The parameters determining the different phases are indicated in the figure. It is intended to characterize different maintenance strategies with the aid of the maintenance phases. The mechanics used to implement the various maintenance processes should be defined in connection with each specific application in the relevant Recommendations. The maintenance phases are described below in more detail.

### 5.1 *Performance measurement*

Different types of performance measuring mechanisms can be used:

- continuous checking;
- routine or periodic testing;
- checking of behavior in live traffic;
- checking of behavior in the absence of live traffic.

The rules governing the measurement mechanisms are defined when conceiving the systems; no intervention of the maintenance personnel is necessary. Under some conditions, however, the personnel can control some operations which may prove necessary for periodic or casual checking, such as:

- modifying the priority level of a checking process;
- modifying the nominal period in the case of periodic checking;
- carrying out some partial or recurrent checks (e.g. test on demand).

The choice of a measurement mechanism depends on the requirements for the “quality of service” as seen by the subscribers, and on the technical network performance and the nature of the equipment. In addition, several mechanisms may be operated in the same item of equipment.

Typical measurement mechanisms are listed below.

#### 5.1.1 *Continuous checking*

All the time an item is active, it is being checked for good performance. If the item does not fulfill the test requirements, it is considered to have a fault.

#### 5.1.2 *Routine or periodic testing*

Items are tested periodically, initiated by either the system or the maintenance staff.

The frequency of the test depends on the importance of the item, the failure rate and the number of items of that type present in the element.

#### 5.1.3 *Checking in live traffic*

Checking behavior in live traffic can be performed directly or statistically.

This checking exists if the ME itself indicates a faulty performance or the continuous detection of anomalies or defects.

All of the elementary information from the different detectors is either retransmitted by each entity to a processing unit or processed locally.

Performance parameters are derived from this information.

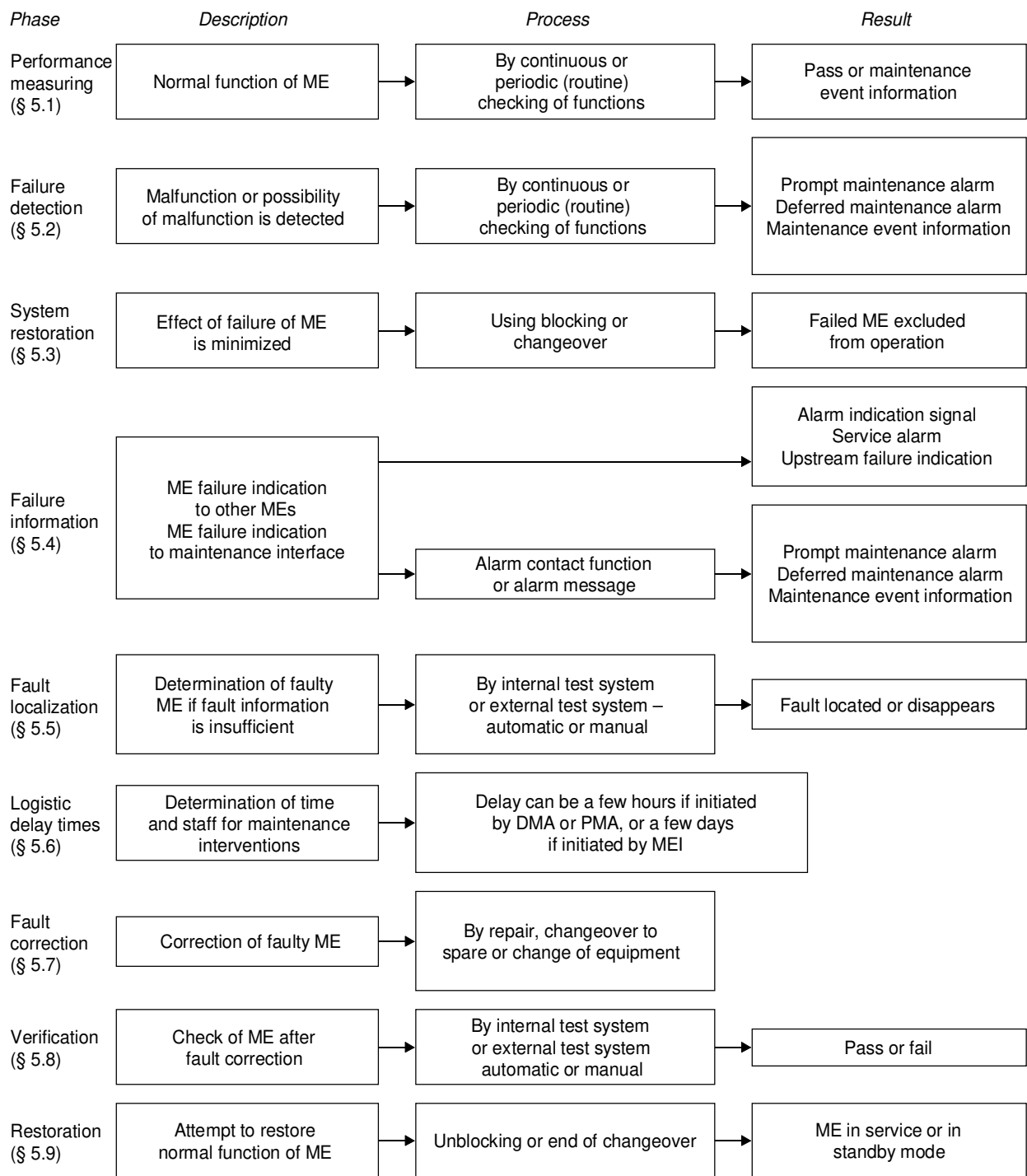

T0403760-93

FIGURE 8/M.20  
Maintenance phases under normal and failure conditions

### 5.1.3.1 Processing of performance parameters

Some performance parameters in use are Errored Seconds (ES) and Severely Errored Seconds (SES) (see Recommendation M.2100 [17]).

Each of the performance parameters (e.g. ES, SES) is to be processed separately in order to evaluate the performance level of the entity's operation.

### 5.1.3.2 *Evaluation of unacceptable performance*

Unacceptable performance is characterized by a significant and long-lasting degradation in quality. It can be associated with the faulty state (see Recommendation M.2100 [17]).

It is ascertained by statistical analysis of each of the performance parameters individually, throughout a given time T1.

As soon as the result of statistical analysis reaches a N1 threshold (defined for each entity individually), the entity is declared to be at an unacceptable level of performance.

Elsewhere, for each defect corresponding to an interruption, lasting  $x$  consecutive seconds, the entity is considered as having reached an unacceptable level.

### 5.1.3.3 *Evaluation of degraded performance*

Each of the performance parameters is analysed statistically over a time T2 which can be a relatively long period.

As soon as the result of statistical analysis reaches a N2 threshold (to be defined), the entity can be considered to be at degraded performance. The time T2 will depend on the entity in question.

This checking leads to maintenance decisions on statistical grounds:

- the number of times in which the item performs its function “normally” is compared with the number of times the performance of the item does not fulfill the requirements;
- the average time of functioning is compared with standard values;
- the number of times an item performs its function during a certain period is compared to normal values.

If the degraded performance level is characterized by a gradual degradation in quality, the maintenance personnel should be informed before this decrease in performance becomes unacceptable to the user.

### 5.1.4 *Checking in the absence of live traffic (traffic is zero)*

Checking of system internal functions is done once a process is over, or when a process has been initiated several times. Examples are operational checks which start when a customer initiates an action to use the network.

## 5.2 *Failure detection*

Failures should be discovered by the Administration independently of, and preferably before, the subscriber, i.e., the majority of failures are both detected and remedied without the subscriber having been aware of them.

Failures are classified depending on their nature (see § 3.2) and may be categorized depending on their severity. Corresponding maintenance alarm information is then passed on to the appropriate entities.

## 5.3 *System restoration*

When a failure has occurred or performance has degraded, the following functions must be performed:

- as a result of the medium and longer period supervision process a signal must be transmitted to all the concerned network equipment of any necessary information for automatic (preferred) initialization of internal or external restoration mechanisms, e.g., reconfiguration, traffic rerouting, etc.;
- decision on any necessary actions, e.g., putting an item “out of service” or “in testing condition”, changing to a configuration with minimal or degraded service.



A specific protection method is recommended for transmission systems using manual or automatic restoration on a maintenance entity basis

- a) If a failure occurs either in maintenance entities without automatic changeover capabilities or with automatic changeover capabilities but without an available stand-by, the following actions should be executed:
  - 1) initiate maintenance alarm information identifying the maintenance entity containing the failed equipment;
  - 2) transmit an alarm indication signal (AIS) in the direction affected (downstream direction) or give an upstream failure indication (UFI) at equipment which has not failed;
  - 3) initiate a service alarm indication at the appropriate entities, e.g. primary PCM multiplex or digital switch interfaces. (As a consequence the circuits may be removed from service.)
- b) If a failure occurs in a maintenance entity having automatic changeover capability with a stand-by available, the following actions should be automatically executed:
  - 1) changeover to the stand-by whether or not connections are released as a result of automatic changeover depends on the service performance objectives assigned to each maintenance entity;
  - 2) initiate maintenance alarm information indicating the maintenance entity containing the failed equipment.

#### 5.4 *Failure or performance information*

Information on failure, unacceptable performance or degraded performance will normally be transmitted to the maintenance staff. Other parts of the network are notified when appropriate.

Information for the use of personnel is available either in the entity, when the processing of anomalies or defects is internal, or via a unit which provides processing, when external to the entity.

##### 5.4.1 *Alarm information categories*

The following maintenance alarm information may be associated with the information of failure or unacceptable or degraded performance:

a) *Prompt maintenance alarm (PMA)*

A PMA is generated in order to initiate maintenance activities (normally immediately) by maintenance personnel to remove defective equipment from service for the purpose of restoring good service and effecting repair of the failed equipment.

b) *Deferred maintenance alarm (DMA)*

A DMA is generated when immediate action is not required by maintenance personnel, e.g;

- when performance falls below a set threshold but the effect does not warrant removal from service;
- when automatic changeover to stand-by equipment has been used to restore service.

c) *Maintenance event information (MEI)*

MEI is generated as a consequence of events when no immediate actions by the maintenance staff are required because the total performance is not endangered. The maintenance actions can be performed on a scheduled basis or after an accumulation of MEI indications.

Starting with the malfunction supervisory process from Figure 7/M.20, Figure 9/M.20 shows the alarm information process for an ME. The actual PMA, DMA or MEI may or may not be generated in the ME. When generated outside the ME, the alarm information process may combine information from other sources (e.g. other MEs, time of day, traffic load, etc.) with the output from the malfunction supervisory process to decide if a PMA, DMA or MEI should be generated. When an AIS or UFI is received, an ME may be required to generate a Service Alarm (SA).

Both the malfunction supervisory process and the alarm information process, including the use of PMAs, DMAs and MEIs, can also be applied to non-telecommunications equipment.

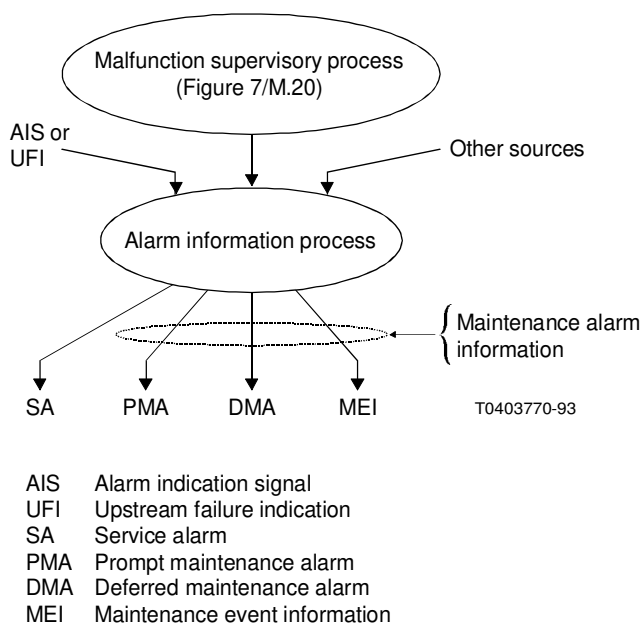

FIGURE 9/M.20  
Alarm information process

#### 5.4.2 Other fault and service indications

In order to avoid unnecessary maintenance actions and to signal the unavailability of the service, the following fault indications are used:

##### a) Alarm indication signal (AIS)

An AIS is a signal associated with a defective maintenance entity and is, when possible, transmitted in the direction affected (downstream direction) as a substitute for the normal signal, indicating to other nondefective entities that a failure has been identified and that other maintenance alarms consequent to this failure should be inhibited. The binary equivalent of the AIS corresponds to an all 1s signal.

*Note 1* – The AIS is different from the “alarm information to the remote end”; see § 5.4.4.

*Note 2* – The AIS capability does not impose any restrictions on the binary content of signals which may be transmitted over the digital hierarchy at the primary multiplex and higher levels. The implications at the 64 kbit/s level and at lower bit rates are under study, since ambiguity arises between AIS and an all 1s information signal.

*Note 3* – For a maintenance entity with multi-destination ends (e.g. in networks with TDMA/DSI satellite systems) alarm indication signals on a circuit basis may be useful. This subject is under study.

*Note 4* – In the particular case of the 44 736 kbit/s hierarchical level, the AIS is defined as a signal

- with a valid frame alignment signal, parity and justification control bits as defined in Table 2/G.752 [6];
- with the tributary bits being set to a 1010 . . . sequence, starting with a binary one (“1”) after each frame alignment, multiframe alignment and justification control bit;
- and with all justification control bits being set to binary zero (“0”).

Demultiplexers of the 44 736 kbit/s hierarchical level must produce the all 1s AIS at their tributary outputs when they receive the 44 736 kbit/s AIS at their high bit rate inputs.

b) *Service alarm (SA)*

An SA is generated at maintenance entities at which the service originates and/or terminates to indicate that the particular service is no longer available (e.g. when a primary block is no longer available for setting up connections, the PCM muldex will extend a service alarm indication to the exchange equipment).

The service alarm should be generated when performance falls below a level specified for a particular service. This level may coincide with that for initiating also a prompt maintenance alarm.

c) *Upstream failure indication (UFI)*

The UFI given by a maintenance entity indicates that the signal arriving at that maintenance entity is defective. The UFI indicates that the failure has occurred upstream of this point, and no unnecessary maintenance activities are initiated.

The appearance of an alarm indicates either a fault in the equipment generating the alarm or a failure of the incoming signal (an upstream failure). To distinguish between these two possibilities it is necessary to provide an independent test, either of the input signal, or of the equipment generating the alarm. The input signal can be checked for proper parity, for example, by a monitor included in the protection switching equipment. A defective input signal indicates an upstream failure. Alternatively, the equipment generating the alarm can be tested independently, (e.g. by looping), and if the equipment operates correctly, an upstream failure is indicated.

### 5.4.3 *Transmission and presentation of alarm information*

The failure information at the alarm interface is used to determine the faulty ME or part of ME. The information can be presented either locally, or remotely via an alarm collection system.

The alarms may be presented as

- an indication at an alarm interface (e.g. contact function, d.c. signal);
- an alarm message on the man-machine interface.

### 5.4.4 *Alarm information to the remote end*

Equipment which is a source of digital multiplex signals (i.e. multiplex equipment or exchanges) may, in case of a fault condition, transmit alarm information within a specified bit or specified bits of the pulse frame. This information is intended for evaluation at the remote terminal (at the end of the digital link). Examples: see Recommendations G.704, § 2.3.2 [7], G.732, § 4.2.3 [8] and G.733, § 4.2.4 [9].

## 5.5 *Fault localization*

Where the initial failure information is insufficient for fault localization within a failing ME, it has to be augmented with information obtained by additional fault localization routines. The routines can employ ME internal or external test systems, initiated manually or automatically, at the local and/or remote end.

A test system, serving one or more MEs could have the following functions:

- alarm collection, e.g. by sampling of alarm interfaces and assembling of alarm messages;
- request for failure information, e.g. by addressing different MEs;
- test programs, e.g. for selection of essential alarms, editing, etc.;
- control of special devices, e.g. for looping measurement of electrical characteristics;
- display of results, e.g. for all MEs within a network region.

It should be particularly noted that

- the corrective maintenance action time and the activity of repair centres (these repair centres may receive unfailed items or sub-items) are strongly conditioned by the localization efficiency (not yet defined);
- if an ME can be subdivided into MSEs, the faulty MSE should be identified as failed in the fault localization process;
- for interchangeable items, the failed item must be identified uniquely.

#### 5.6 *Logistic delay*

The logistic delay is the period of time between the fault localization and arrival of the maintenance staff on site. The logistic delay will depend on the type of failures and how they are reported, i.e. by PMA, DMA or MEI.

Following a PMA or DMA alarm, fault correction will be performed normally in the course of a specific trip of the maintenance staff. The logistic delay may vary from a few hours in the case of PMA alarms, to a few days in the case of DMA alarms.

Following an MEI, which indicates that no immediate actions are necessary, the maintenance action can be postponed until the next scheduled maintenance visit unless an accumulation of MEIs demands earlier action.

#### 5.7 *Fault correction*

Fault correction normally requires change or repair of an ME, MSE or a part thereof. One or more fault corrections can be performed in the course of a maintenance visit. It is desirable that strategies be developed to accomplish fault correction satisfying overall maintenance objectives with a minimum number of visits, using the concept of logistic delay.

Failed interchangeable items will be sent to a specialized repair centre, where appropriate test equipment is available (the system itself should not act as a test machine).

Normally, cooperation between maintenance elements in different Administrations will result in the satisfactory identification and correction of faults. There may be circumstances, however, where the fault escalation procedures defined in Recommendations M.1550 [24] and M.1560 [25] may be required.

#### 5.8 *Verification*

After the fault has been corrected, checks must be made to ensure the ME is working properly. The verification can be made locally or remotely.

#### 5.9 *Restoration*

The repaired part of the ME or MSE is returned to service. Blocked MEs are unblocked.

### **6 Additional maintenance activities**

In addition to the above-mentioned phases, the following activities may be required:

## 6.1 *Maintenance support*

Maintenance support covers the functions identified below:

- management of information of network equipment in operation;
- management of operating data (routing data mainly);
- correction instruction for hardware and software;
- repairing of removable items;
- management of spare parts;
- network and equipment documentation.

The quantity of spare parts held depends on

- organization of maintenance entities;
- failure rate of an item;
- turn around time (actual repair time, transport);
- number of items in operation;
- risk that no spare part is available.

## 6.2 *Failure statistics*

If all failures are recorded, this information, after processing, can serve the following organizational functions:

- management, e.g. evaluating system performance;
- organization of maintenance, e.g. use of test equipment, subscriber complaints versus test results, amount of spare parts;
- maintenance activities, e.g. identifying weak components where preventive maintenance actions are necessary.

## 6.3 *Preventive maintenance actions*

Mechanical parts (such as magnetic equipment heads) have to be cared for periodically.

After analyzing failure statistics, decisions can be made to interchange items even before failures have occurred, if they seem to be weak items.

## 7 **Other maintenance considerations**

### 7.1 *Reference test frequency considerations*

Under study.

### 7.2 *Use of maintenance test lines and loop-backs*

Under study.

### 7.3 *Maintenance of common channel Signalling System No. 7 networks*

Under study.

## **References**

- [1] CCITT Recommendation Q.22 *Specification for CCITT automatic transmission measuring and signalling testing equipment ATME No. 2.*
- [2] CCITT Supplement No. 6.2 *New operation and maintenance organization in the Milan Italcable Intercontinental telecommunication centre*, Blue Book, Vol. IV.

- [3] CCITT Recommendations G.700 to G.956 *Digital networks*.
- [4] CCITT Supplement No. 6 *Terms and definitions for Quality of Service, network performance, dependability and trafficability studies*, Blue Book, Fascicle II.3.
- [5] CCITT Recommendation G.821 *Error performance on an international digital connection forming part of an integrated services digital network*.
- [6] CCITT Recommendation G.752 *Characteristics of digital multiplex equipment based on a second order bit rate of 6312 kbit/s and using positive justification*.
- [7] CCITT Recommendation G.704 *Functional characteristics of interfaces associated with network nodes*.
- [8] CCITT Recommendation G.732 *Characteristics of primary PCM multiplex equipment operating at 2048 kbit/s*.
- [9] CCITT Recommendation G.733 *Characteristics of primary PCM multiplex equipment operating at 1544 kbit/s*.
- [10] CCITT Recommendation M.60 *Maintenance terminology and definitions*.
- [11] CCITT Recommendation M.70 *Guiding principles on the general maintenance organization for telephony-type international circuits*.
- [12] CCITT Recommendation M.710 to M.725 *General maintenance organization for the international automatic and semi-automatic telephone service; fault report point; testing point; network analysis point; circuit control station; restoration control point*.
- [13] CCITT Recommendation M.80 *Control stations*.
- [14] CCITT Recommendation M.90 *Sub-control stations*.
- [15] CCITT Recommendation M.21 *Principles for maintenance philosophy and considerations for maintenance strategy for telecommunication services*.
- [16] CCITT Recommendation M.3010 *Principles for a telecommunications management network*.
- [17] CCITT Recommendation M.2100 *Performance limits for bringing-into-service and maintenance of international digital paths, sections and transmission systems*.
- [18] CCITT Recommendation M.34 *Performance monitoring on international transmission systems and equipment*.
- [19] CCITT Recommendations M.450 to M.475 *Bringing-into-service, setting up and lining up, etc*.
- [20] CCITT Recommendations M.570 to M.590 *Constitution of the circuit, setting up and lining up an international circuit, bringing-into-service an international digital circuit, etc*.
- [21] CCITT Recommendation M.4030 *Transmission characteristics for setting up and lining up a transfer link for CCSS No. 6*.
- [22] CCITT Recommendation M.4100 *Maintenance of CCSS No. 7*.
- [23] CCITT Recommendation M.2110 *Bringing digital paths, sections and transmission systems into service*.
- [24] CCITT Recommendation M.1550 *Escalation procedure*.
- [25] CCITT Recommendation M.1560 *Escalation procedure for international leased circuits*.
- [26] CCITT Recommendation M.1000-Series *International leased circuits*.

ANNEX A

(to Recommendation M.20)

**Alphabetical list of abbreviations used  
in this Recommendation**

AIS	Alarm indication signal
ATME	Automatic transmission measuring equipment
CTE	Channel translation equipment
DIG MUX	Digital muldex
DMA	Deferred maintenance alarm
DSI	Digital speech interpolation
ES	Errored second
ET	Exchange terminal
GTE	Group translation equipment
ISDN	Integrated services digital network
LT	Line terminal
ME	Maintenance entity
MEA	Maintenance entity assembly
MEF	Maintenance entity function
MEI	Maintenance event information
MSE	Maintenance sub-entity
NE	Network element
NEF	Network element function
NT	Network terminal
OS	Operating system
PMA	Prompt maintenance alarm
SA	Service alarm
SEF	Support entity function
SES	Severely errored second
STE	Supergroup translation equipement
TA	Terminal adaptor
TDMA	Time division multiple access
TE	Terminal equipment
TMN	Telecommunication management network
UFI	Upstream failure indication