



INTERNATIONAL TELECOMMUNICATION UNION

**CCITT**

**I.324**

THE INTERNATIONAL  
TELEGRAPH AND TELEPHONE  
CONSULTATIVE COMMITTEE

**INTEGRATED SERVICES  
DIGITAL NETWORK (ISDN)**

**OVERALL NETWORK ASPECTS  
AND FUNCTIONS,  
ISDN USER-NETWORK INTERFACES**

---

**ISDN NETWORK ARCHITECTURE**

**Recommendation I.324**

---



Geneva, 1991

## FOREWORD

The CCITT (the International Telegraph and Telephone Consultative Committee) is a permanent organ of the International Telecommunication Union (ITU). CCITT is responsible for studying technical, operating and tariff questions and issuing Recommendations on them with a view to standardizing telecommunications on a worldwide basis.

The Plenary Assembly of CCITT which meets every four years, establishes the topics for study and approves Recommendations prepared by its Study Groups. The approval of Recommendations by the members of CCITT between Plenary Assemblies is covered by the procedure laid down in CCITT Resolution No. 2 (Melbourne, 1988).

Recommendation I.324 was prepared by Study Group XVIII and was approved under the Resolution No. 2 procedure on the 25 of October 1991.

---

## CCITT NOTES

- 1) In this Recommendation, the expression "Administration" is used for brevity to indicate both a telecommunication Administration and a recognized private operating agency.
- 2) A list of abbreviations used in this Recommendation can be found in Annex A.

© ITU 1991

All rights reserved. No part of this publication may be reproduced or utilized in any form or by any means, electronic or mechanical, including photocopying and microfilm, without permission in writing from the ITU.

## Recommendation I.324

### ISDN NETWORK ARCHITECTURE

(Melbourne, 1988; amended at Geneva, 1991)

## 1 General

### 1.1 Basic philosophy

The objective of this Recommendation is to provide a common understanding of the CCITT studies on the general architecture of an ISDN from the functional point of view. The model is not intended to require or exclude any specific implementation of an ISDN, but only to provide a guide for the specification of ISDN capabilities.

### 1.2 Definitions

A number of terms used in this Recommendation are described in more detail in other Recommendations. To assist the understanding of the reader, the following particular definitions apply in this Recommendation:

- 1) **reference configurations** are conceptual configurations which are useful in identifying various possible arrangements in an ISDN. The reference configurations are based on association rules of functional groupings and reference points. Detailed descriptions of reference configurations for ISDN connection types are given in other I-Series Recommendations. For user-to-network access they are defined in Recommendation I.411 and for interworking between networks they are defined in the I.500-Series of Recommendations.
- 2) **functional groupings** are sets of functions which may be needed in ISDN arrangements. The relationship between generic functions and specific functions allocated to particular entities (or functional groupings) in the ISDN are explained in Recommendation I.310.
- 3) **reference points** are the conceptual points at the conjunction of two functional groupings. In a particular example, a reference point may correspond to a physical interface between pieces of equipment, or in other examples, there may not be any physical interface corresponding to the reference point. Interfaces will not be defined by CCITT for an ISDN unless the corresponding reference points have been already specified.

## 2 General architecture of an ISDN

In practical ISDN implementations some of the ISDN functions will be implemented within the same network elements, whereas other specific ISDN functions will be dedicated to specialized network elements. Various different ISDN implementations are likely to be realized depending on national conditions.

A basic component of an ISDN is a network for circuit switching of end-to-end 64 kbit/s connections. In addition to this connection type, depending on national conditions and evolution strategies, the ISDN will or will not support other connection types, such as packet mode connection types and  $n \times 64$  kbit/s circuit mode connection types, and other broadband connection types.

## 2.1 *Basic architectural model*

A *basic architectural model of an ISDN* is shown in Figure 1/I.324. This shows the eight main switching and signalling functional capabilities of an ISDN:

- ISDN local connection related functions (CRF), see § 4.2.2.1;
- 64 kbit/s circuit switched functional entities;
- 64 kbit/s circuit non-switched functional entities. (The identification and definition for 8, 16, 32 kbit/s switched or non-switched functional entities is left for further study.);
- packet switching functional entities;
- frame mode functional entities;
- common channel inter-exchange signalling functional entities, for example conforming to CCITT Signalling System No. 7;
- switched functional entities at rates greater than 64 kbit/s;
- non-switched functional entities at rates greater than 64 kbit/s.

These components need not be provided by distinct networks, but may be combined as appropriate for a particular implementation.

High layer functions (HLF) which may be implemented within (or associated with) an ISDN may be accessed by means of any of the above-mentioned functional entities. Those functional entities could be implemented totally within an ISDN or be provided by dedicated networks or specialized service providers. Both cases may provide the same ISDN teleservices (see Recommendation I.210) from the user's point of view.

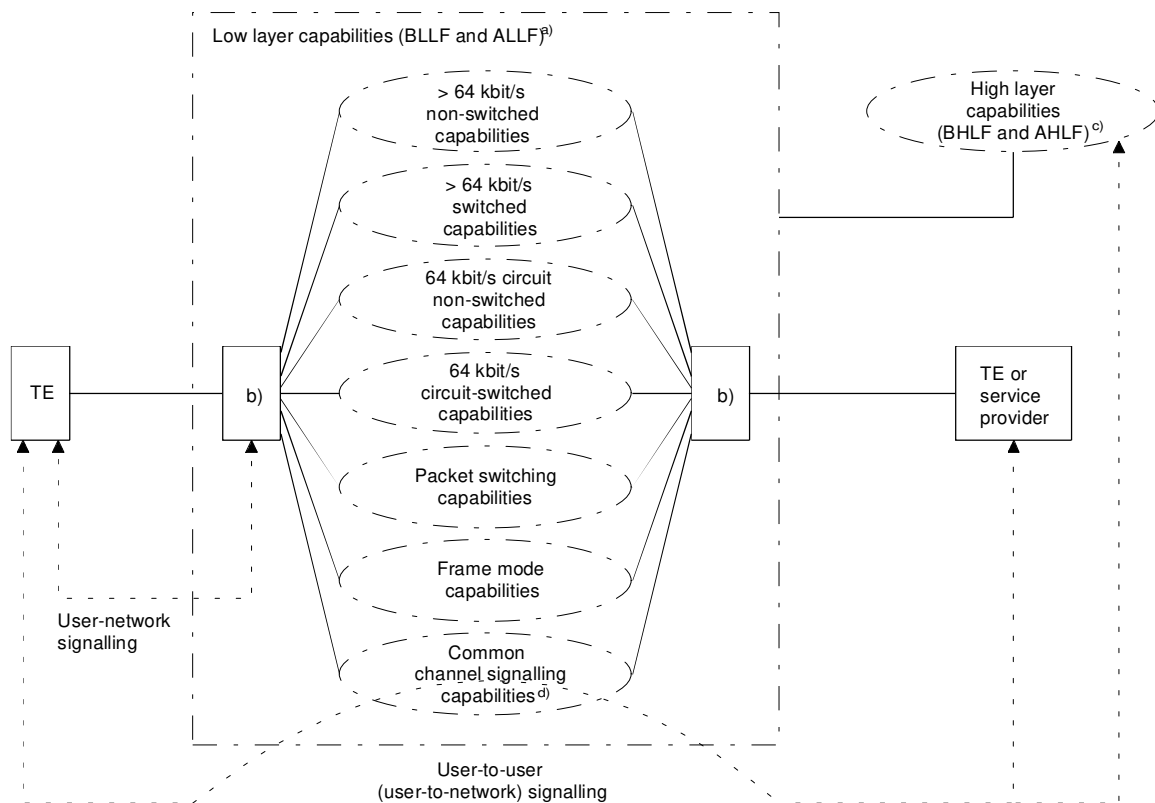

TE Terminal equipment  
 BLLF Basic low layer functions  
 ALLF Additional low layer functions  
 BHLF Basic high layer functions  
 AHLF Additional high layer functions

T1812710-91

- a) In certain national situations, ALLF may also be implemented outside the ISDN, in special nodes or in certain categories of terminals.
- b) The ISDN local functional capabilities correspond to functions provided by a local exchange and possibly including other equipment, such as electronic cross connect equipment, muldexes, etc.
- c) These functions may either be implemented within ISDN or be provided by separate networks. Possible applications for basic high layer functions and for additional high layer functions are contained in Recommendation I.210.
- d) For signalling between international ISDNs, CCITT Signalling System No. 7 shall be used.

FIGURE 1/I.324

Basic architectural model of an ISDN

## 2.2 *Architectural components of the ISDN*

Recommendation I.310 describes the functions of an ISDN. These functions are by their nature static (i.e. time-independent). The relative distribution and allocation of these functions is the subject of the architecture of the ISDN and is described in this Recommendation. The dynamic aspects of these functions are modelled in Recommendation I.310 as executive processes.

Therefore the key components in this architectural model are: what functions are contained in the ISDN, where they are located, and what is the relative topology for their distribution in the ISDN.

## 3 **Aspects of the architecture of the ISDN**

The architecture of the ISDN includes low layer capabilities and high layer capabilities. These capabilities support services both within the ISDN and via interworking (see § 5) to other networks.

### 3.1 *Low layer capabilities*

From the main functional capabilities of the ISDN, as shown in Figure 1/I.324, four main functional capabilities require further description.

#### 3.1.1 *Circuit switching capabilities*

Circuit-switched connections with information transfer rates up to 64 kbit/s are carried by B-channels at the ISDN user-network interfaces and switched at 64 kbit/s by the circuit-switching functional entities of the ISDN. Circuit switching can also be applied to information transfer rates greater than 64 kbit/s.

Signalling associated with circuit switched connections is carried by the D-channel at the ISDN user-network interface and processed by the local CRF (see § 4.2.2.1). User-to-user signalling could be carried through the common channel signalling functional entities (in the transit connection elements).

User bit rates of less than 64 kbit/s are rate adapted to 64 kbit/s, as described in Recommendation I.460, before any switching can take place in the ISDN. Multiple information streams from a given user may be multiplexed together in the same B-channel, but for circuit switching an entire B-channel will be switched to a single user-network interface. This multiplexing should be in accordance with Recommendation I.460. Furthermore, circuit switched data services with bit rates less than 64 kbit/s (in accordance with Recommendation X.1 user classes of service) may be handled by a dedicated circuit switched public data network to which the user gains access by means of an ISDN connection.

Circuit switching capabilities are based on 64 kbit/s switching. Connection types at higher bit rates could also be provided on a semi-permanent basis. Switched connections at these bit rates could also be provided by broadband switching functional entities.

#### 3.1.2 *Packet switching capabilities*

A number of packet mode bearer services are described in the I.230-Series of Recommendations. Different network solutions and corresponding architectures may be adopted in different countries to support these services.

Recommendations I.310 (ISDN-Network functional principles), I.462 (Support of packet mode terminal equipment by an ISDN) and Q.513 (Exchange interfaces for operations, administration and maintenance) constitute the basis for the description of packet switching functions in an ISDN.

Two types of functional groupings are involved in the provision of packet switched bearer services by an ISDN:

- packet handling functional groupings, which contain functions relating to the handling of packet calls within the ISDN;
- interworking functional groupings, which ensure interworking between ISDN and packet switched data networks.

The solutions which could be used to access packet bearer services are:

- via the B-channel, with the following cases:
  - circuit (switched or semi-permanent) access through ISDN to an interworking function within a PSPDN,
  - circuit (switched or semi-permanent) access associated with packet handling functions and/or interworking functions in the ISDN,
  - circuit (switched or semi-permanent) access associated with packet handling functions within the ISDN;
- via the D-channel, with the following cases:
  - packet handling functions and interworking functions within the ISDN,
  - packet handling functions in the ISDN (without interworking functions).

*Note* – This classification does not preclude a combination of the solutions described above.

Depending on national considerations, the ISDN packet handling and interworking functions can be centralized or distributed. The following cases may be encountered:

- packet handling and interworking functions are not integrated in the local CRF (e.g., they are located in a transit CRF);
- packet handling functions are integrated in the local CRF;
- packet handling functions and/or interworking functions are integrated in the local CRF.

### 3.1.3 *Frame mode capabilities*

Frame mode bearer services are described in Recommendation I.233. They aim to support a wide range of data applications and rates from very low, to high (typically 2 Mbit/s). A typical application might be interconnection between local area networks (LANs).

Frame mode capabilities provide the order preserving bidirectional transfer of service data units (layer 2 frames) from one S or T reference point to another. The data units are routed through the network on the basis of an attached label. This label is a logical identifier with local significance (termed DLCI in the protocol description).

The user-network interface structure at an S or T reference point allows for the establishment of multiple virtual calls and/or permanent virtual circuits to many destinations. This bearer capability is generally available on the following ISDN access arrangements: point-to-multipoint (passive bus) and point-to-point (NT2).

All control-plane procedures (signalling) associated with frame mode bearer services, if needed, are performed in a logical separate manner using protocol procedures that are integrated across all ISDN telecommunication services.

The user-plane procedures at layer 1 are based on Recommendations I.430/I.431. Layer 2 procedures are based on the core functions of Recommendations Q.922. These layer 2 core functions allow for the statistical multiplexing of user information flows immediately above layer 1 functions.

#### 3.1.4 *Other switching capabilities*

For the support of broadband connections, other switching capabilities in addition to the above-mentioned switching capabilities could be employed (see Recommendation I.327 for B-ISDN functional architecture).

#### 3.1.5 *Transmission capabilities*

In addition to the normal transmission capabilities of the IDN (integrated digital network), the following transmission aspects are important when considering the architecture of the ISDN. Services which do not require unrestricted digital information transfer capability, such as telephony, may also employ non-transparent channels (e.g., packetized voice, digital speech interpolation). Channels at 8, 16, 32 kbit/s may be used in the transmission part of the network; they may be used to support some services (e.g., voice-band connection types). They may also be used in cases where a B-channel (at the S or T reference point) carries user data streams at bit rates lower than 8, 16, 32 kbit/s respectively.

#### 3.2 *High layer capabilities*

Normally the high layer functions (HLFs) are involved only in the terminal equipment, but for the support of some services, provision of HLFs could be made via special nodes in the ISDN belonging to the public network or to centres operated by other organizations and accessed via ISDN user-network or inter-network interfaces. Some services such as Message Handling service (MHS) may be used on a large scale and the relevant functional entities could be provided within the ISDN exchanges. For both cases the protocols used to activate such services should be identical and integrated with the general user procedures defined for the activation of ISDN teleservices.

## **4 Location of functions in the ISDN**

### 4.1 *Overall*

In considering an ISDN call (i.e. an instance of a telecommunication service) two major functional areas are involved:

- i) the customer equipment (TE and optional customer network);
- ii) the public ISDN connection type.

Recommendation I.411 describes the functional groupings and reference configurations for the customer network, while Recommendation I.412 describes the channel structures to be used at reference points S and T. The partitioning of the functions involved in ii), the ISDN connection type, is described in § 4.2 below.

Figures 2/I.324 and 2a/I.324 illustrate this overall division of functions involved in a communication across the ISDN.



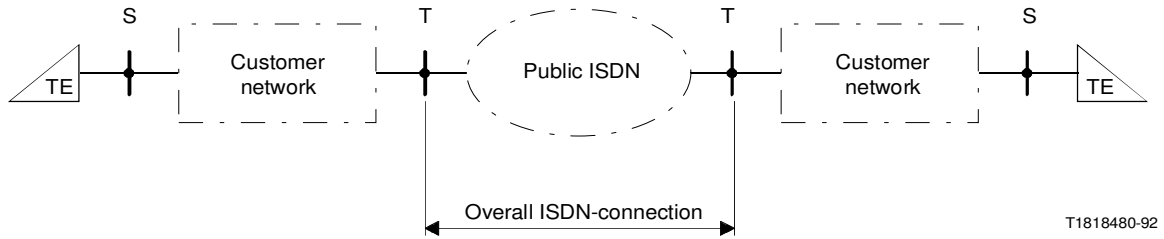

T1818480-92

TE Terminal equipment

*Note 1* – The functional grouping customer network is described in Recommendation I.411.

*Note 2* – In the case where the customer network is null (i.e. null NT2) then the ISDN connection can be considered to end at the S and T coincident reference points.

*Note 3* – In the case where the customer network is an ISPBX based network, providing the same ISDN connection types according to Recommendation I.340 as the public ISDN does, then the ISDN connection ends at the S reference point as shown in Figure 2a/I.324.

*Note 4* – Other configurations are possible where the call is asymmetrical, or terminates in or involves HLFs.

*Note 5* – The terms "Customer networks" and "Public ISDN" do not presuppose a particular regulatory situation in any country and are used purely for technical reasons. The connection type concept is defined in Recommendation I.340.

FIGURE 2/I.324  
General ISDN reference configuration

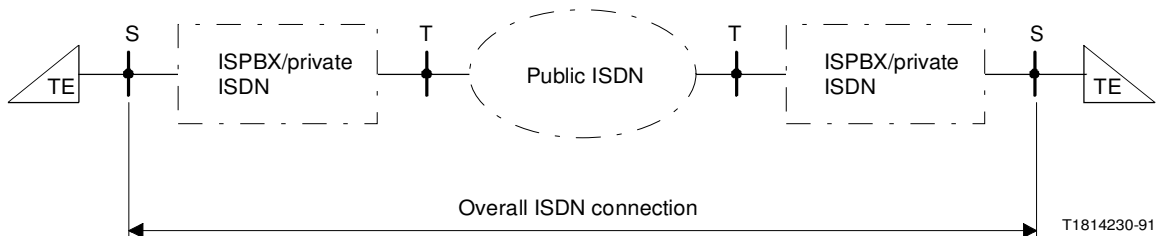

T1814230-91

*Note* – This reference configuration applies to the case where the customer network consists only of ISPBXs. The case in which "IS-CENTREXS" are included is for further study.

FIGURE 2a/I.324  
Overall ISDN reference configuration for a mixed  
ISPBX/public ISDN scenario

#### 4.2 Partitioning of the ISDN connection type

The distribution of functions within the ISDN connection type is known as the connection type reference configuration. The partitions of the connection type to allow this distribution are described below. The detailed reference configurations for groups of connection types can be found in Recommendation I.325.

4.2.1 Connection elements

The first level of partitioning of the ISDN connection type is the connection element. The partitioning is based on the two most critical transitions of a connection: firstly the change of signalling system, secondly the international transmission system(s). These two points generate three kinds of connection elements: access connection element, national transit connection element, and international connection element. These three connection elements allow the description of both the access and transit capabilities to support services. However, in the case of performance allocation, for example, the access connection element and the national transit connection element may be fused into one national connection element. This allows for the variation in the nature of the local plant and regulatory environments in different countries according to national policies.

The partitioning into connection elements corresponding to Figure 1/I.324 is shown in Figure 3/I.324.

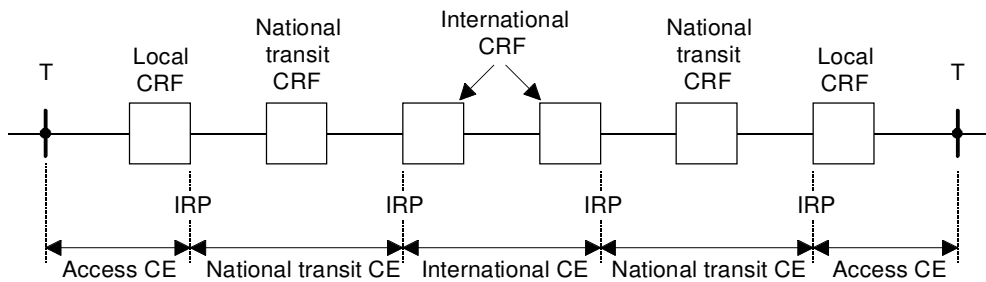

T1818490-92

IRP Internal reference point  
 CRF Connection related functions  
 CE Connection element

FIGURE 3/I.324

Reference configuration of public ISDN connection type

In the case where the customer network consists of ISPBXs (see Figure 2a/I.324), two additional kinds of connection elements, a private access CE, and a private transit CE are identified as shown in Figure 3a/I.324.

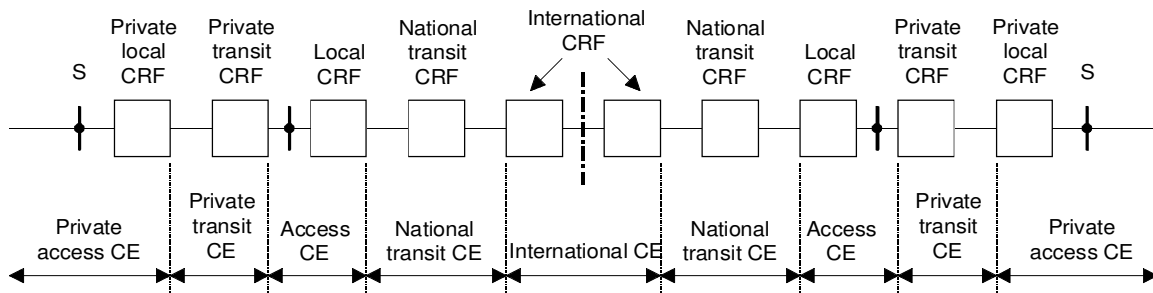

T1818500-92

CRF Connection related functions  
 CE Connection element

Note – The internal reference points (IRP) have been erased in this figure.

FIGURE 3a/I.324

Reference configuration of overall ISDN connection types for a mixed ISPBX/public ISDN scenario

#### 4.2.1.1 Access connection element

The access connection element is bounded by the T reference point at the customer end and the reference point which marks the transition from the access signalling system to the common channel signalling system on the network side.

The model for the access connection element in the case of 64 kbit/s circuit switched is shown in Figure 4/I.324. Depending on the national situations and on the type of access, a number of different possibilities are available for this element, in particular with regard to the use of multiplexer (Mpx) or remote switching units (RSU).

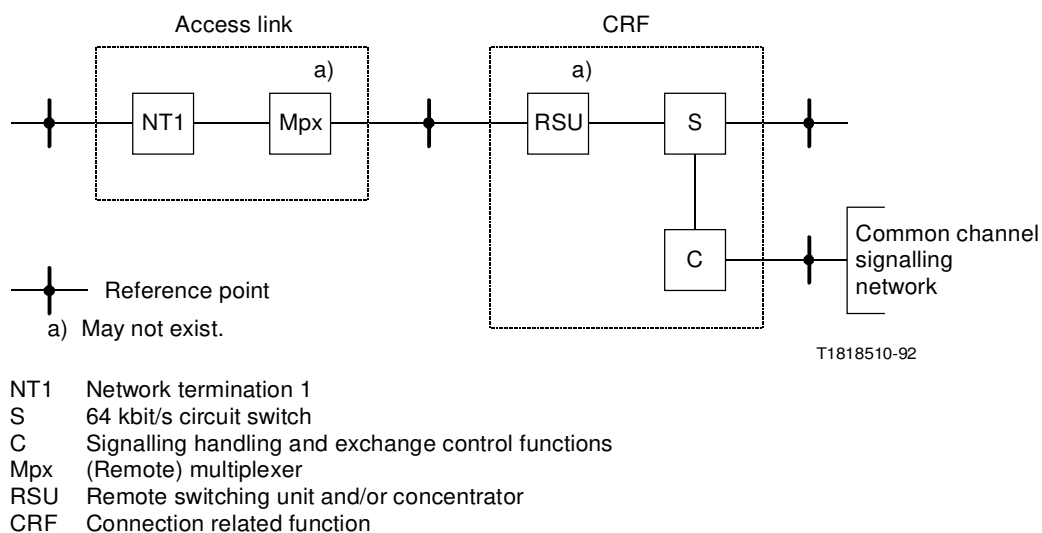

FIGURE 4/I.324  
**Access connection element model**

#### 4.2.1.2 National transit connection element

The national transit connection element is bounded by the transition from access signalling system to common channel signalling systems and the *first* international switching centre. In the case of a national connection this would default to a “transit connection element”, i.e. between two local CRFs, but could involve network elements from more than one network operator.

In some instances, the first international exchange (and the international CRF) may be in close proximity to the local and national transit CRF. This is a national matter.

The model for the national transit connection is shown in Figure 5/I.324.

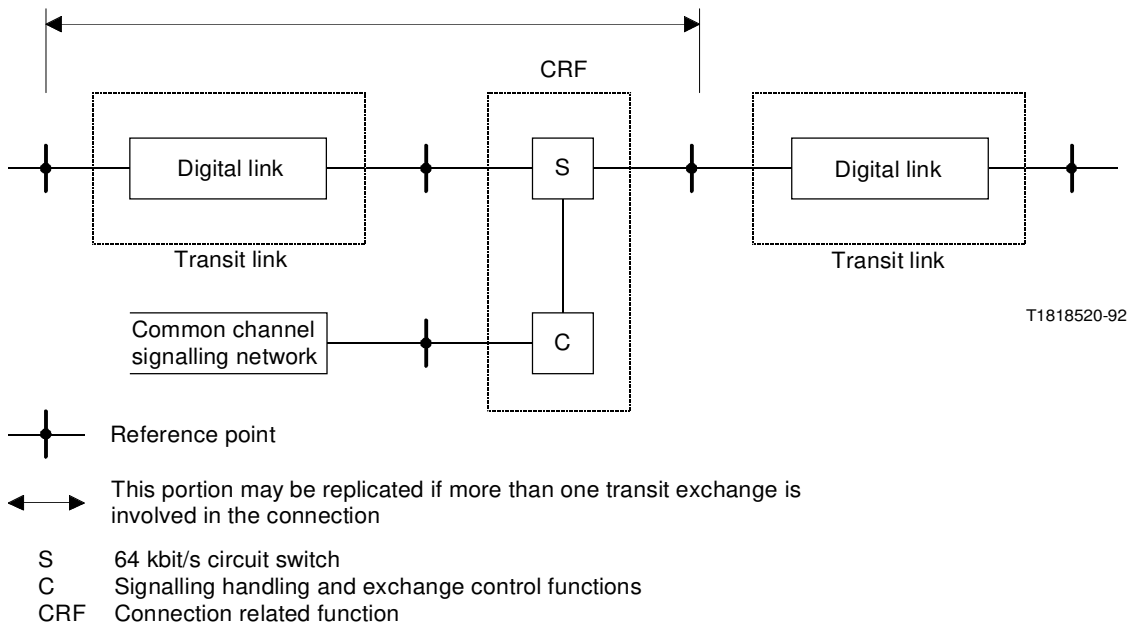

FIGURE 5/I.324  
**National transit connection element model**

4.2.1.3 *International connection element*

The international connection element is bounded by the originating and destination international switching centre (ISC). A number of transit international exchanges may be involved to bridge long international connections. With satellite connections, fewer international transits may be required.

Figure 6/I.324 shows an international connection element model. Figure 7/I.324 shows an international connection element model made by a concatenation of several links and exchanges.

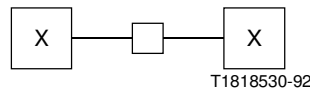

FIGURE 6/I.324  
**International connection element model**

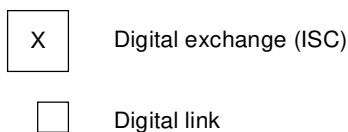
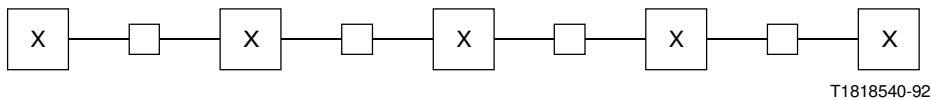

FIGURE 7/I.324  
**International connection element model masking use of several links and exchanges**

4.2.1.4 Private access connection element

The private access connection element is bounded by the S reference point at the terminal equipment access to the ISPBX/private ISDN and the reference point which marks the transition from the private access signalling and transmission system to the private inter-exchange signalling system, or if the private transit connection element is null, to the digital subscriber line signalling system DSS of the public ISDN at the T reference point. See Figure 8/I.324.

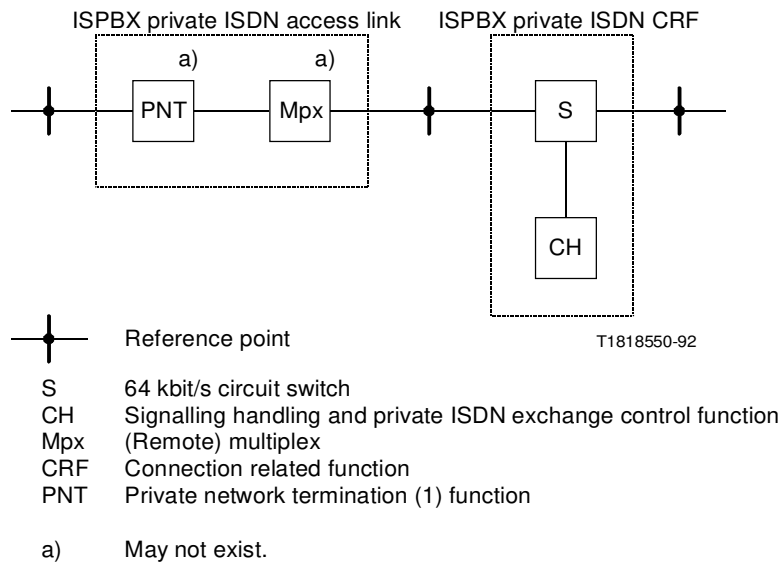

FIGURE 8/I.324  
Private ISDN access connection element

4.2.1.5 Private transit connection element

The private transit connection element is bounded by the ISPBX/private ISDN CRF and the reference point which marks the transition from the transit connection element to the T reference point, i.e. the access connection element of the public ISDN. In the case of an intra-private ISDN connection, this could default to an inter-ISPBX/intra-private ISDN transit connection element, i.e. between two local ISPBX/private ISDN CRFs, but could involve network elements from more than one private or public network operator. See Figure 9/I.324.

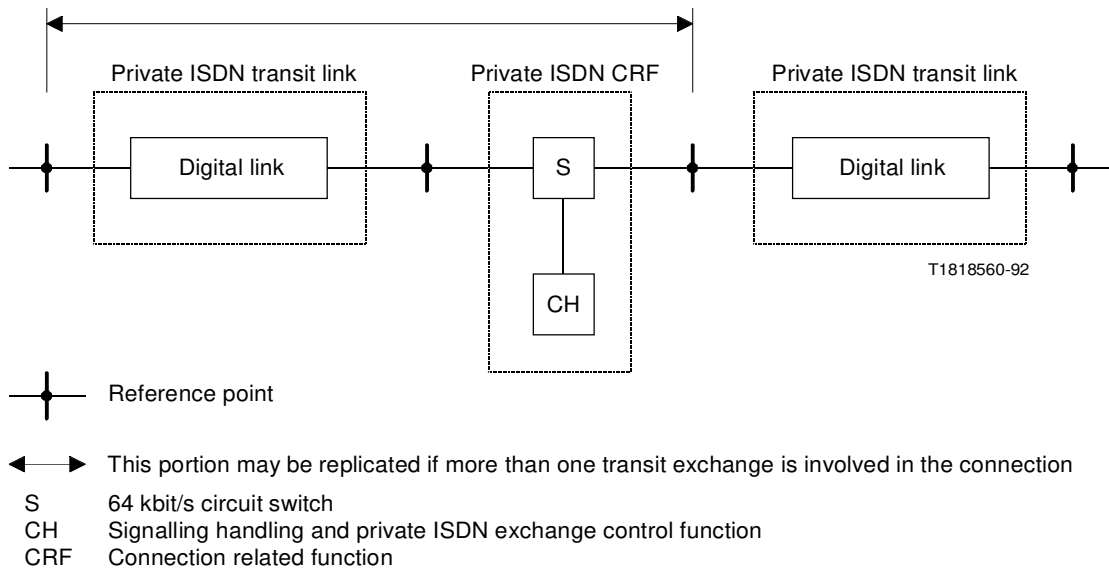

FIGURE 9/I.324  
Private ISDN transit connection element

#### 4.2.1.6 *Future additional connection elements*

Connection elements for interworking and connection to specialized resources and services are also required.

#### 4.2.2 *Basic connection components*

The basic connection components (BCC) allow for the analysis of system performance. There are three forms of BCC: connection related function, access links and transit links. Broadly, CRFs cover switching aspects, and links cover transmission aspects.

##### 4.2.2.1 *Connection related function*

The connection related function includes all aspects involved in establishing and controlling the connections within the particular connection element. This includes functions such as exchange terminations, switching, control, network management, operation and maintenance. The specific capabilities of each CRF are not specified in the general reference model: this is done in the reference configuration for each group of connection types.

##### 4.2.2.2 *Access link*

The access link includes the NT1 and may include a multiplexer, along with the required transmission equipment to link the customer network to the local CRF.

##### 4.2.2.3 *Transit link*

The transit link is a digital link as described in Recommendations G.701 and G.801.

#### 4.2.3 *Functional groupings*

Functional groupings are sets of functions which may be needed in the ISDN. In a particular instance, specific functions in a functional grouping may or may not be present. Note that specific functions in a functional group may be performed in one or more pieces of equipment. Examples of functional groupings are line termination (LT), exchange termination (ET), and packet handling (PH) function. Further study is required on functional groupings for the public ISDN connection type.

#### 4.2.4 *Reference points*

The other element involved in the description of a reference configuration is the reference point concept. The I-Series already identifies reference points S and T (in Recommendation I.411) and K, M, N, P (in the present Recommendation). As can be seen from Figure 4/I.324, some further internal reference points need to be identified. Further study is required to see whether these and any further reference points need to be defined.

In describing the reference configuration for the public ISDN connection types, an important consideration vis-a-vis the reference points is the following. In Figure 3/I.324 the end points of the overall connection is shown as being at the T reference point. The reason for this is as follows. Reference point S is identical to reference point T when the NT2 function is null (see Recommendation I.411). When the NT2 function is non-zero, then the performance of the overall connection will be made up of the performance of the ISDN network connection (i.e. between the two interfaces at reference point T) and the sum of the performance of the customer network connections (i.e. between the interfaces at reference points S and T at each end). Recommendation G.801 also uses this approach by defining the areas of the digital hypothetical reference connection (HRX) as being at the T reference point.

## 5 Architectural relationship between the ISDN and other networks including ISDNs

A key element of service integration for an ISDN is the provision of a limited set of standard multi-purpose user-network interfaces.

It is important to note that the introduction of ISDN capabilities into a network requires a massive development effort. Consequently, Administrations will be introducing various ISDN functions successively over a course of time. For example, the 64 kbit/s circuit switched capability may be introduced initially, followed by provision of packet switching features, and so on.

An ISDN will therefore have to interwork with a set of various dedicated networks or terminals in order to:

- i) provide ISDN connections to non-ISDN terminal equipment (TE2) through dedicated networks;
- ii) provide a non-ISDN terminal equipment (TE2) connected by means of a terminal adaptor (TA) with access to non-ISDN services provided by a dedicated services network;
- iii) ensure that an ISDN terminal connected to ISDN interworks with a non-ISDN terminal connected to a dedicated network.

The dedicated networks will offer services (e.g. public data network services) that are either available or not available within an ISDN. Some of the dedicated networks could be integrated into the ISDN in the future, depending on national conditions. Connections have to be allowed between terminals, both connected to an ISDN, or for terminals where one is connected to the ISDN and the other is connected to the dedicated network.

The I.500-Series of Recommendations describe the characteristics of interworking.

The I.400-Series of Recommendations describe the characteristics of user-network interfaces for the following cases:

- 1) access of a single ISDN terminal;
- 2) access of a multiple ISDN terminal installation;
- 3) access of multiservice PABXs, local area networks or, more generally, private networks;
- 4) access of non-ISDN terminal;
- 5) access of specialized storage and information processing centres.

In addition, considering that the evolution to a comprehensive ISDN will take place over a long period of time, the connection of non-ISDN customers to an ISDN via analogue lines as well as interworking with existing networks or other ISDNs, will be necessary. These cases include:

- 1) access to telephone networks and to dedicated networks (e.g. packet network, telex network);
- 2) access to another ISDN;
- 3) access to service providers outside the ISDN.

The ISDN user-network interfaces or internetwork interfaces may be used in the above cases. The definition of internetwork interfaces is necessary for these arrangements for interworking and administrative requirements.

Interworking with other networks or other ISDNs requires in some cases the provision of interworking functions (IWF), either within the ISDN or in the other network (see Recommendations of the I.500-Series). These functions would ensure interworking between different protocols and user procedures.

Within a country or geographical area, an ISDN connection may be formed across several interconnected networks, each of which is characterized by the attributes of one or more ISDN connection types (as defined in Recommendation I.340).

Figure 10/I.324 depicts the ISDN user-network reference points as defined in the I.400-Series of Recommendations, as well as reference points at which internetwork interfaces between an ISDN and other networks (including other ISDNs) may exist. Whether inter-network interfaces at all of these reference points will be defined by CCITT Recommendations is for further study.

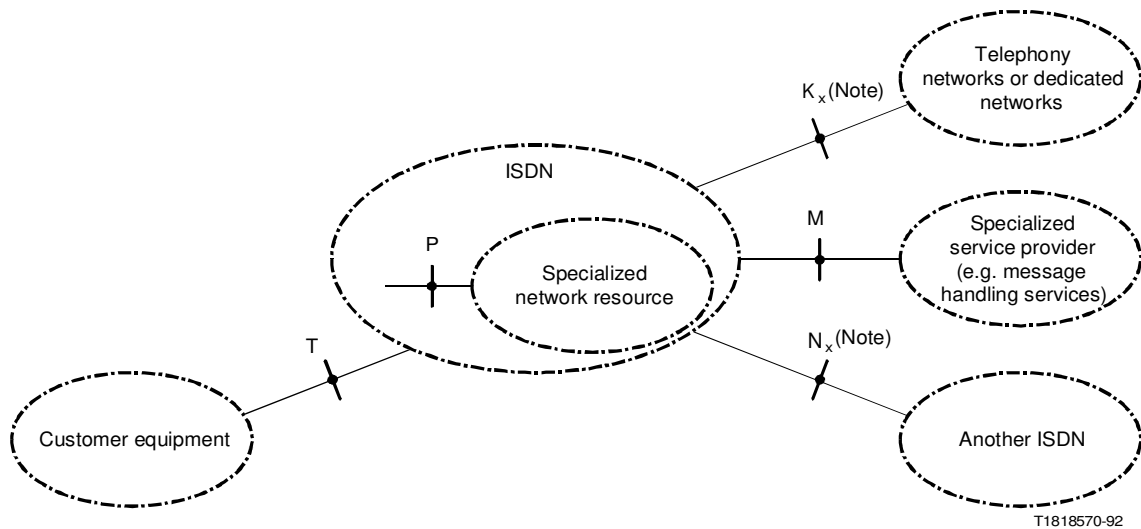

T1818570-92

*Note* –  $x = 1$  indicates that interworking functions exist inside ISDN while  $x = 2$  would indicate no such functions are required inside of ISDN. No assumptions are made regarding interworking functions outside of ISDN. Therefore, irrespective of the value of  $x$ , the possibility of interworking functions in the other network, between the networks or a combination of these possibilities are kept open. Preferred solutions within the framework given above will be indicated in other Recommendations dealing with service/network specific cases of interworking.

The case of  $N_1$  covers the situation when interworking functions are split between the two ISDNs involved.

FIGURE 10/I.324  
Reference points for interconnection of customer equipment  
and networks to an ISDN



Examples of possible interworking situations are given in Figures 11/I.324, 12/I.324 and 13/I.324.

Figure 11/I.324 shows cases where some ISDN services are also provided to subscribers connected to dedicated networks. In these circumstances ISDNs have to interwork with such networks.

Figure 12/I.324 primarily shows cases where a dedicated network is used to carry a given class of ISDN services. As an example, a dedicated packet switched network providing X.25 services to its subscribers could be used to set up ISDN packet connections between two ISDN subscribers. From an ISDN services perspective, this could be viewed as a subset of ISDN.

The dedicated network may be composed of dedicated transmission and switching facilities or be restricted to a set of special nodes linked together via connections, provided through the circuit switched part of the ISDN network, as illustrated in Figure 13/I.324, for the example of a packet switched network.

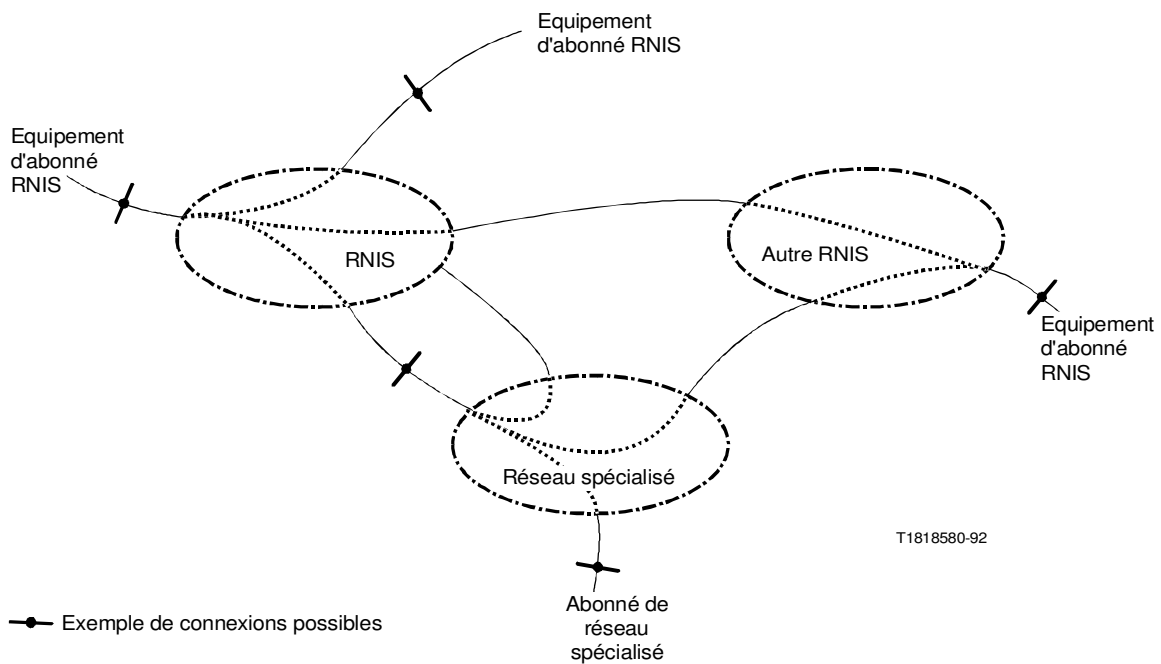

FIGURE 11/I.324  
Interfonctionnement avec un réseau spécialisé

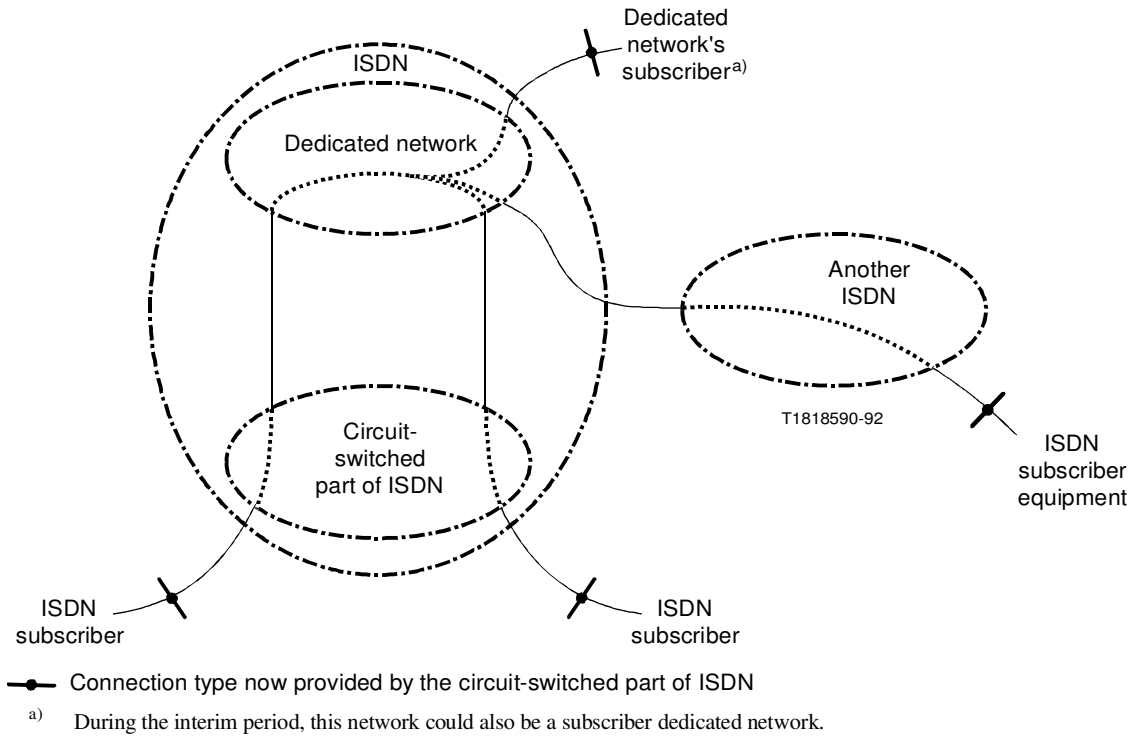

FIGURE 12/I.324

Use of a dedicated network for setting up some ISDN connection types

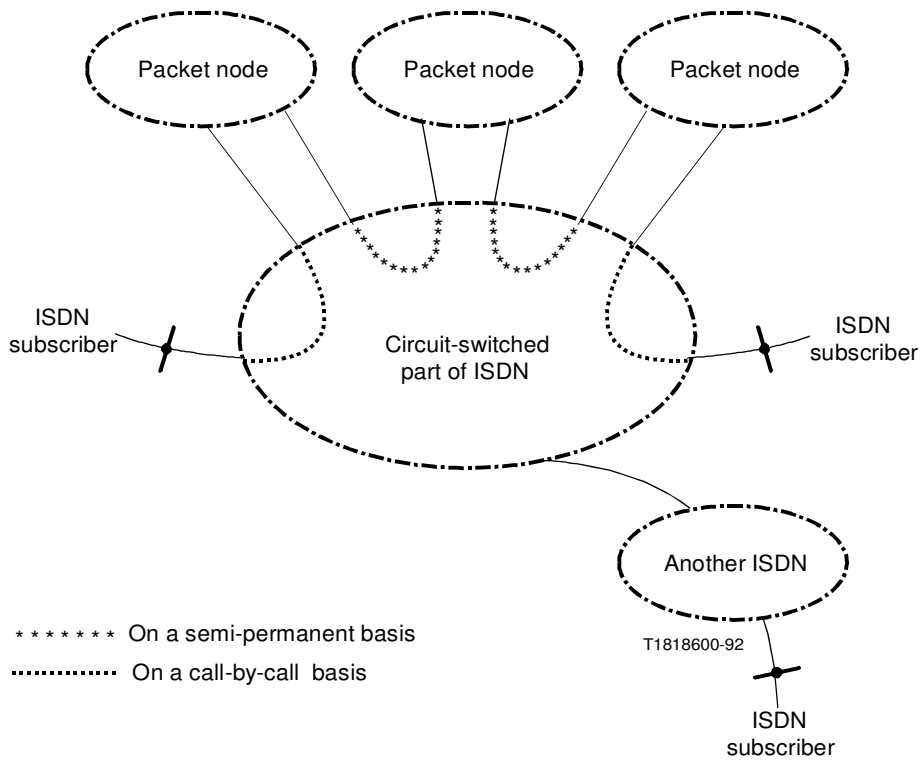

FIGURE 13/I.324

Dedicated logical packet switched network

ANNEX A

(to Recommendation I.324)

**Alphabetical list of abbreviations used in this Recommendation**

AHLF	Additional high layer function
ALLF	Additional low layer function
BCC	Basic connection component
BHLF	Basic high layer function
BLLF	Basic low layer function
CE	Connection element
CH	Signalling handling and private ISDN exchange control function
CRF	Connection related function
DLCI	Data link connection identifier
ET	Exchange terminaison
HLF	High layer function
HRX	Digital hypothetical reference connection
IDN	Integrated digital network
IRP	Internal reference point
ISC	International switching centre
IWF	Interworking function
LAN	Local area network
LT	Line termination
MHS	Message handling service
Mpx	Multiplexer
NT1	Network termination 1
PH	Packet handling
PNT	Private network termination function
RSU	Remote switching unit
TA	Terminal adaptor
TE	Terminal equipment