



INTERNATIONAL TELECOMMUNICATION UNION

ITU-T

TELECOMMUNICATION
STANDARDIZATION SECTOR
OF ITU

G.911

(03/93)

DIGITAL SECTIONS AND DIGITAL LINE SYSTEMS

**PARAMETERS AND CALCULATION
METHODOLOGIES FOR RELIABILITY AND
AVAILABILITY OF FIBRE OPTIC SYSTEMS**

ITU-T Recommendation G.911

(Previously "CCITT Recommendation")

FOREWORD

The ITU Telecommunication Standardization Sector (ITU-T) is a permanent organ of the International Telecommunication Union. The ITU-T is responsible for studying technical, operating and tariff questions and issuing Recommendations on them with a view to standardizing telecommunications on a worldwide basis.

The World Telecommunication Standardization Conference (WTSC), which meets every four years, established the topics for study by the ITU-T Study Groups which, in their turn, produce Recommendations on these topics.

ITU-T Recommendation G.911 was prepared by the ITU-T Study Group XV (1988-1993) and was approved by the WTSC (Helsinki, March 1-12, 1993).

NOTES

1 As a consequence of a reform process within the International Telecommunication Union (ITU), the CCITT ceased to exist as of 28 February 1993. In its place, the ITU Telecommunication Standardization Sector (ITU-T) was created as of 1 March 1993. Similarly, in this reform process, the CCIR and the IFRB have been replaced by the Radiocommunication Sector.

In order not to delay publication of this Recommendation, no change has been made in the text to references containing the acronyms "CCITT, CCIR or IFRB" or their associated entities such as Plenary Assembly, Secretariat, etc. Future editions of this Recommendation will contain the proper terminology related to the new ITU structure.

2 In this Recommendation, the expression "Administration" is used for conciseness to indicate both a telecommunication administration and a recognized operating agency.

© ITU 1994

All rights reserved. No part of this publication may be reproduced or utilized in any form or by any means, electronic or mechanical, including photocopying and microfilm, without permission in writing from the ITU.

CONTENTS

Page

1	Introduction	1
2	Parameters related to reliability and availability of fibre optic systems	1
2.1	Fibre optic system availability and maintenance reliability-related parameters	1
2.2	Active optical device reliability parameters	2
2.3	Passive optical device reliability parameters	2
2.4	Optical fibre and cable reliability parameters	2
3	Definitions	3
4	Steady-state reliability prediction method of devices, units and fibre optic systems in serial configuration ...	4
4.1	Purpose and scope	4
4.2	Applications of the predicted failure rate method	5
4.3	Guidelines	5
4.4	Steady-state failure rate prediction method	6
5	Calculation methodologies for fibre optic system devices, units and systems in serial configuration regarding reliability and maintenance parameters	7
5.1	Plug-in circuit pack MTBF	7
5.2	System MTBF (terminal and repeater)	8
5.3	Frequency of scheduled maintenance actions	9
5.4	Random failure rate	9
5.5	Infant mortality factor	9
6	Calculation methodology of availability and maintenance parameters of fibre optic systems with line protection	9
6.1	General considerations – Line protection and network protection	9
6.2	State-space methodology to determine availability and maintenance parameters in fibre optic systems with line protection	10
6.3	Options of fibre systems with line protection	14
7	Reference circuits for end-to-end channel availability of line systems on optical fibres	15
8	Allocation methodology for end-to-end unavailability objectives	17
8.1	Contributors to unavailability – Considerations regarding SDH and PDH systems on optical fibres	17
8.2	Allocation methodology	17
Annex A	– Determination of unit steady-state failure rate – Example	19
A.1	Unit description (example)	19
A.2	Reliability parameters of devices (example)	19
A.3	Unit steady-state failure rate (FITs)	19
Annex B	– Study case channel availability for a 4 × 140 Mbit/s repeater link on optical fibres with “3 + 1” line protection	20
B.1	Description	20
B.2	Results – Unavailability (minutes/year) per 140 Mbit/s channel	22
Annex C	– Study case – Channel availability for a point-to-point fibre connection in the local network with “1 + 1” line protection, with and without cable-path redundancy	22
C.1	Description	23
C.2	Results	25

PARAMETERS AND CALCULATION METHODOLOGIES FOR RELIABILITY AND AVAILABILITY OF FIBRE OPTIC SYSTEMS

(Helsinki, 1993)

1 Introduction

This Recommendation provides details of the parameters needed to characterize and the procedures to predict and calculate fibre optic system reliability, including reliability of the devices and availability of channels transmitted through the systems. The emphasis is on single-mode fibre systems (see Figure 1).

2 Parameters related to reliability and availability of fibre optic systems

2.1 Fibre optic system availability and maintenance reliability-related parameters

This subclause gives the system service parameters and system maintenance parameters. The values may be provided in study cases and are for further study. It is anticipated, however, that different parameters/values may be required for the various system applications, including point-to-point long/medium distance, local networks, etc. (see Tables 1 and 2).

TABLE 1/G.911

System service parameter	Units
Mean system availability ^{a)}	Min/yr unavailability
Mean channel availability	Min/yr unavailability per channel
Operation system interface availability	Min/yr unavailability
^{a)} In order to estimate the quantity of spares required.	

TABLE 2/G.911

System service parameter	Units
System MTBF (such as terminals, repeaters and media)	Years
Plug-in circuit pack MTBF ^{a)}	Years
Frequency of scheduled maintenance actions	Events per year
Random failure rate	Events per year
Infant mortality factor	Dimensionless
MTBF (<i>mean time between failures</i>)	
^{a)} In order to estimate the quantity of spares required.	

2.2 Active optical device reliability parameters

This subclause includes reliability parameters for characterizing active fibre optic devices such as lasers, LEDs and detectors. The values may be provided in study cases and are for further study (see Table 3).

TABLE 3/G.911

Active optical device reliability parameter	Units
Median life (ML)	Years
Standard deviation (σ)	
Wear-out failure rate at 10 years (λ_{10}) Wear-out failure rate at 20 years (λ_{20})	FITs FITs
Wear-out activation energy (E_n)	eV
Random (steady-state) failure rate (λ_r)	FITs
Random failure activation energy (E_n)	eV

2.3 Passive optical device reliability parameters

This subclause includes the necessary reliability parameters for characterizing passive fibre optic devices such as connectors, splices and splitters. Identification of the parameters and their values are for further study (see Table 4).

TABLE 4/G.911

Passive optical device reliability parameter	Units

2.4 Optical fibre and cable reliability parameters

This subclause includes the necessary reliability parameters for characterizing optical fibres and cables. Different parameters may be required for different system applications, and require further study (see Table 5).

TABLE 5/G.911

Optical fibre and cable reliability parameter	Units

3 Definitions

This clause includes definitions for the reliability parameters for characterizing fibre optic systems and device reliability. The source and code number in CCITT are written in brackets (CCITT *Blue Book* Supplement No. 6 of Fascicle II.3).

- 1) **item; or entity** (such as a system or a channel) – Any part, device, sub-system, functional unit, equipment or system that can be individually considered [DV 3001].
- 2) **constant failure rate period** – That possible period in the life of a non-repaired item during which the failure rate is approximately constant.

NOTE – In any particular case it is necessary to explain what is meant by “approximately constant” [DV 7308].

- 3) **availability performance** – The ability of an item to be in a state to perform a required function at a given instant of time or at any instant of time within a given time interval, assuming that the external resources, if required, are provided.

NOTES

1 This ability depends on the combined aspects of the reliability performance, the maintainability performance and the maintenance support performance of an item.

2 In the definition of the item the external resources required must be delineated.

3 The term availability is used as an availability performance measure [DV 4002].

- 4) **instantaneous availability** – The probability that an item is in an up-state at a given instant of time, t [DV 8101].
- 5) **mean availability** – The normalized integral of the instantaneous availability in a given time interval (t_1 , t_2) [DV 8103].
- 6) **mean time between failures (MTBF)** – The expectation of the time between failures [DV 8208].
- 7) **early failure period (infant mortality)** – That possible early period in the life of an item, beginning at a given instant of time and during which the instantaneous failure intensity for a repaired item or the instantaneous failure rate for a non-repaired item decreases rapidly.

NOTE – In any particular case, it is necessary to explain what is meant by “decreases rapidly” [DV 7306].

- 8) **infant mortality factor (IMF)** – Ratio of the expected number of failures in a specific early period (e.g. the first year) of service to the expected number of failures in a period of the same length of time in steady-state operation (before wear out).
- 9) **median life (ML)** – With respect to optoelectronic devices, the median life refers to the point, on a lognormal probability plot of device times-to-failure at which 50% of the devices fail earlier and 50% of the devices fail later. (See Note 1 of item 21).
- 10) **standard deviation (σ)** – With respect to optoelectronic devices, the standard deviation refers to the normal mathematical expression for this statistic as calculated from the natural logarithms of the device times-to-failure. (See Note 2 of item 21).

- 11) **wear-out failure period** – That possible later period in the life of a repaired item during which the instantaneous failure intensity for a repaired item or the instantaneous failure rate for a non-repaired item increases rapidly.

NOTE – In any particular case it is necessary to explain what is meant by “increases rapidly” [DV 7309].

- 12) **wear-out failure rate** – The wear-out failure rate is a measure of the number of items that fail per unit time due to wear-out mechanisms. It is not calculated directly for optoelectronic devices, but is obtained from the statistical expectation for a lognormal distribution for which the median life and standard deviation have been estimated.
- 13) **wear-out failures** – A failure whose probability of occurrence increases with the passage of time, as a result of processes inherent in the item [DV 5209].
- 14) **activation energy (E_n)** – The minimum centre-of-mass kinetic energy required before a chemical reaction can occur. Normally expressed in units of electron volts (eV). Used as a part of the early life Arrhenius acceleration factor.

- 15) **Arrhenius acceleration factor** - An expression detailing the relationship between failure times at two different temperatures.

$$\frac{t_1}{t_2} = e^{\frac{E_0}{\kappa} \left(\frac{1}{T_1} - \frac{1}{T_2} \right)}$$

where:

- $t_{1,2}$ is the time to failure,
 E_0 is the activation energy in electron volts (eV),
 κ Boltzman constant, 8.6×10^{-5} eV/K,
 $T_{1,2}$ is the absolute temperature, K.

- 16) **random failure rate** – The random failure rate is a measure of the number of units that fail per unit time due to a variety of fabrication or (more often) assembly defects not associated with the usual wear-out mechanism(s). A common assumption for optoelectronic devices is that the collection of random failure mechanisms can be roughly modeled by an exponential distribution. In that case, the failure rate is not obtained directly from the data, but is obtained from the (one-sided) statistical expectation for an exponential distribution for a given level of confidence (e.g. a 60% confidence limit).
- 17) **maintenance time** – The time interval during which a maintenance action is performed on an item either manually or automatically, including technical delays and logistic delays [DV 7101].
- 18) **mean time to repair (MTTR)** – The total corrective maintenance time divided by the total number of corrective maintenance actions during a given period of time [DV 8310].
- 19) **frequency of maintenance actions** – The inverse of the mean time interval between the starts of successive maintenance actions over a given time period (in events per a given period of time).
- 20) **FITs (failures in time)** – Normally expressed as failures per billion device hours.
- 21) **steady-state availability** – The steady-state availability is the limit of $A(t)$ when t goes to infinity. Being $A(t)$ the probability that the item is operating at a specified time t and is given by:

$A(t)$ – Probability ($X(t) = 1$)

where:

$X(t)$ denotes the state at time t of a system undergoing maintenance. If the system is operating at time t then $X(t) = 1$, if not, then $X(t) = 0$.

NOTES

- 1 For the definition of “mean value of the useful life” see DV 7305.
- 2 See also DV 2010.

4 Steady-state reliability prediction method of devices, units and fibre optic systems in serial configuration

4.1 Purpose and scope

As used here, reliability is a measure of the frequency of equipment failure as a function of time. Reliability has impact on maintenance cost and on the continuity of service. Reliability predictions can be used to assist in deciding which product from a list of competing products should be purchased. As a result, it is essential that reliability predictions from competing products be based on common procedures (see Note 1).

The purpose of this procedure for reliability prediction is to recommend a common procedure for reliability prediction. The method is intended to be applicable to electronic units/systems, in general, and for those units/systems to be used with fibre cables in particular.

This reliability prediction method is based in a failure-rate “parts count” approach (see Note 2).

NOTES

1 It is important to recognize that failure rates of component parts may be based on standards that may be different from one manufacturer to another (such discrepancies can arise from differences in generic failure rates and other factors related to environment, stress, quality, etc.).

2 Other methods exist for reliability prediction purposes, including:

- statistical estimates based upon combining data from a laboratory test with predictions from the “parts count” method;
- statistical estimates of in-service reliability based upon field tracking studies.

The scope is limited to hardware-related failures under steady-state conditions. The infant mortality factor prediction method is for further study. Complex systems with reliability objectives for individual functions or for various states of reduced service capability are outside the scope of this recommendation.

4.2 Applications of the predicted failure rate method

It may be used in the following situations.

4.2.1 Equipment manufacturers/suppliers

The method contains instructions for product suppliers to follow when providing predictions of their product's reliability.

The supplier may employ another method (see above) for reliability prediction of devices, units and systems in serial configuration, however, the parts-count is also needed as reference method.

4.2.2 Equipment owners and network operators

It can be used by equipment owners and/or network operators to perform the following tasks:

- a) to request and evaluate the reliability of products to be purchased. Reliability predictions provide data for life cycle cost analysis;
- b) to measure service-affecting parameters related to the product reliability.

By combining reliability predictions with maintenance parameters (such as mean time to repair) the following service-affecting parameters can be calculated:

- frequency of outages in steady-state;
 - frequency of maintenance actions;
 - expected value of the downtime per year;
- c) to provide a measure of line system reliability as it affects maintenance activity. For example, predictions of the frequency of maintenance and/or repair actions can be obtained.

4.3 Guidelines

4.3.1 Definition of failure

The definition of failures should be made specific. The definition of failure is a critical element in predicting system reliability. For simple equipment the definition of failure is usually clear.

Faults in complex equipment (as could be the case of line system in fibre cables) may distinguish between those affecting maintenance or repair and those affecting service (e.g. “major fault” BER > 10⁻⁴).

4.3.2 Operating conditions

The physical environment in which the units/systems will be used should be described, including:

- temperature and humidity, and their variations;
- single or redundant line facility;
- commercial power outages;
- EMI, lightning.

4.3.3 Environmental description

Failure rates vary as a function of the intended operating environment. The appropriate environmental failure rate multiplication factor(s) should be specified. If the overall system will be exposed to more than one environment, each factor should be specified as appropriate.

4.3.4 Adjusting the estimates given by this method

Although the method specified here is intended to be the reference one, this does not preclude use of other technically-sound sources of data and/or technically-sound engineering techniques in estimating device, unit or system failure rate. This could include (as mentioned above) device manufacturer's data, unit supplier data, reliability physics considerations and engineering analysis. This adjusting of the estimates given by the reference method may be particularly useful for new technology devices where no substantial field data may exist.

4.4 Steady-state failure rate prediction method

4.4.1 Applicability of the method

This method applies whenever the supplier wishes to take advantage of device or unit burn-in.

The failure intensity corresponding to failures affecting maintenance represents the quantity of repairs to be made per unit of time, and is equal to the sum of the failure rates of all the devices building the considered item.

For non-redundant items, the failure intensity corresponding to failures affecting service represents the quantity of service impairments per unit of time, and is equal to the sum of the failure rates of the devices whose failure affect the service.

For redundant items, the methods for deriving the service affecting failure intensity depends on the type of redundancy as well as on the way the redundancy is implemented.

4.4.2 Device steady-state failure rate (λ_{si})

For this general situation the steady-state failure rate is given by:

$$\lambda_{si} = N_i \mu_{gi} \pi_{qi} \pi_{si} \pi_{ti}$$

where:

N_i is the quantity of i th device;

μ_{gi} is the generic failure rate for the i th device;

π_{qi} is the quality factor for the i th device (see Note);

π_{si} is the stress factor for the i th device (see Note);

π_{ti} is the temperature factor for the i th device due to normal operating temperature during steady-state A distinction must be made between environment temperature and intrinsic temperature of the device/unit.

NOTE – Those factors may be different by each network operator standard or manufactures standard.

4.4.3 Unit steady-state failure rate (λ_s)

The unit steady-state failure rate is the sum of the device steady-state failure rates:

$$\lambda_s = \pi_e \sum_{i=1}^{i=N} \lambda_{si}$$

where:

N is the number of different N_i devices in the unit;

π_e is the environmental failure rate multiplicative factor.

NOTE – An example is given in Annex A.

4.4.4 Line system steady-state failure rate (λ_{sys})

If the specified reliability parameters failure criteria, equipment configuration and operating conditions indicate that a serial reliability model is appropriate, the total system failure rate (λ_{sys}) will be the sum of all of the unit steady-state failure rates (λ_s) that is: (see Note 2)

$$\lambda_{sys} = \sum_{j=1}^{j=M} \lambda_s(j)$$

where:

$\lambda_s(j)$ is the unit steady-state failure rate for unit j ;

M is the number of units.

NOTES

1 Unit steady-state failure rates are assumed to reflect only service affecting failures.

2 In the case of redundant systems, redundant equipment and/or unit/panel constitution, the sum of all of the failure rates (λ_s) is not appropriate in terms of total system reliability. The production method to be used in such situations is under study.

5 Calculation methodologies for fibre optic system devices, units and systems in serial configuration regarding reliability and maintenance parameters

5.1 Plug-in circuit pack MTBF

The mean time between failures (MTBF) is the steady-state expectation of the time between failures. Mathematically, the MTBF (in years per failure) is related to the failure rate (in FITs or failures per 10^9 hours) as follows:

$$M = \frac{(1.14 \cdot 10^5)}{F}$$

where M is the MTBF (in years per failure) and F is the failure rate (in FITs).

The plug-in circuit pack MTBF is calculated by summing the failure rate for each of the elements that comprise the circuit pack. For example, Table 6 shows the calculation for a circuit pack having one packaged laser with a failure rate of 1500 FITs, five integrated circuits each with a failure rate of 300 FITs, four resistors each with a failure rate of 123 FITs, seven capacitors each with a failure rate of 57 FITs and a connector and printed wiring board, each with a failure rate of 27 FITs.

The unit FIT rates for the elements comprising the circuit pack can be calculated in a number of ways. The calculation methodology shall be detailed when reporting plug-in circuit pack MTBF.

TABLE 6/G.911

Example of plug-in circuit pack MTBF calculation

Device type	Quantity	Unit FIT rate	Total FITs
Packaged laser	1	1500	1500
Integrated circuits	5	300	1500
Resistors	4	123	492
Capacitor	7	57	399
Connector	1	27	27
PWB	1	27	27
Total			3945 FITs
$MTBF = \frac{1.14 \cdot 10^5}{3945} = 28.9 \text{ years}$			

5.2 System MTBF (terminal and repeater)

The mean time between failures (MTBF) is the steady-state expectation of the time between failures. Mathematically, the MTBF (in years per failure) is related to the failure rate (in FITs or failures per 10⁹ hours) as follows:

$$M = \frac{(1.14 \cdot 10^5)}{F}$$

where *M* is the MTBF (in years per failure) and *F* is the failure rate (in FITs).

The system MTBF is calculated by summing the failure rate for each of the plug-in circuit packs (and other equipment that is not on plug-in circuit packs) that comprise the system. For example, Table 7 shows the calculation for a system having five channel packs each with a failure rate of 8000 FITs, four power supplies each with a failure rate of 6500 FITs, four regenerators each with a failure rate of 12 050 FITs, a microprocessor board with a failure rate of 12 300 FITs and a monitor board with a failure rate of 3400 FITs.

TABLE 7/G.911

Example of system MTBF calculation

Device type	Quantity	Unit FIT rate	Total FITs
Channel pack	5	8 000	40 000
Power supply	4	6 500	26 000
Regenerator	4	12 050	48 200
Microprocessor board	1	12 300	12 300
Monitor board	1	3 400	3 400
Total			129 900 FITs
$MTBF = \frac{1.14 \cdot 10^5}{1.299 \cdot 10^5} = 0.878 \text{ years}$			

5.3 Frequency of scheduled maintenance actions

The frequency of scheduled maintenance actions is the mean time interval between the starts of successive scheduled preventive maintenance actions. It is determined by calculating the interval between successive scheduled maintenance actions. For example, if a fibre optic system supplier requires scheduled maintenance actions to occur every six months, the frequency of maintenance actions would be two events per year.

5.4 Random failure rate

The random failure rate is a measure of the number of units that fail per unit time due to a variety of fabrication or (more often) assembly defects not associated with the usual wear-out mechanism(s). The system random failure rate is determined by summing the random failure rate for each of the elements that comprise the system including service affecting failures, non-service affecting failures and all scheduled and unscheduled maintenance actions. The random failure rates for the elements comprising the system can be calculated in a number of ways. The calculation methodology shall be detailed when reporting system random failure rates.

5.5 Infant mortality factor

The infant mortality factor (IMF) is the ratio of the expected number of failures in the first period of service to the expected number of failures in a steady-state year. It is calculated based on two parameters. The expected number of failures in the first period is calculated by determining the area under the Weibull infant mortality curve over a first time period beginning with the time service is first applied by the customer. The Weibull curve is determined based on the sum of those curves for the elements in the system. The expected number of failures during a steady-state year is calculated by determining the random failure rate and converting to failures per year.

6 Calculation methodology of availability and maintenance parameters of fibre optic systems with line protection

6.1 General considerations – Line protection and network protection

Protection in telecommunication transmission is largely concerned with providing degrees of redundancy to increase the overall availability of end-to-end customer circuits. This is necessary because the net availability performance obtained by cascading large numbers of network elements is incompatible with the expectations of many customers.

The goal of a redundant network is a high level of circuit availability as perceived by the customer, but this, of course, can only be achieved at some cost to the operator. In simplest terms this extra cost is due to the increased hardware needed to provide standby circuits through the network. However two other important cost factors must be allowed for, namely the cost of control mechanisms (e.g. software) used to ensure that failed circuits are restored and the cost of extra maintenance staff needed to repair the additional faulty equipment resulting from the increase in network hardware.

Protection methods in telecommunication may be categorized in terms of path availability, response time and complexity. Generally fast, simple methods such as “N + 1” link protection have been preferred since they reduce unavailability by about one order of magnitude, compared with unprotected systems (see Annexes B and C), at minimal additional cost. Also link protection systems may be readily automated to give further significant improvements with minimal hardware for protection switches, signalling and control. Ring protection is a special case of “1 + 1” protection where traffic may be routed in both directions around the ring.

More complex protection schemes involve networking, either by simple triangularization (using a fixed set of pre-programmed make-good paths), or global re-routing, that requires a full knowledge of the network for the by-pass of failed equipment. Both link and network protection are applicable to meshed networks but require complex signalling and control software. However, the apparent improvement in circuit availability offered by networking may be offset by the additional complexity of software and vulnerability under catastrophic situations (natural or man-made).

6.2 State-space methodology to determine availability and maintenance parameters in fibre optic systems with line protection

The methodology is further illustrated through samples of Annexes B and C. The method is composed of three steps which are described below:

6.2.1 Step 1 – Inputs

Deals with the information needed to work out the other steps. That information includes

- a) random (steady state) failure rates of the various devices/network elements;
- b) repair rates based on MTTRs of the various elements and sub-systems;
- c) architectural configuration of the line protection scheme.

6.2.2 Step 2 – From the above inputs determine

- d) *The set of states* – A mathematically tractable probability model that can account for many simultaneously-active events processed in a complex system is a continuous-time, homogeneous Markov chain. What follows deals with such Markov approach.

Each state corresponds to a specific condition of the system, for example: “component A is failed”, “failure detected”, “loss of redundancy”, “repair in progress”, and “system failed”.

- e) Breaking state-transition diagram.

Systems are frequently first described by reliability block diagrams that define what combinations of system elements are needed to provide a system function. For example, Figure 2 shows a parallel system with two components (λ_A and λ_B) which are the components failure rates. Transition paths depicting repair are left for simplicity in Figure 2. A bar on the top of the component means that such component is failed. The states \bar{A}, B and A, \bar{B} mean a component has failed but the system still works. The state \bar{A}, \bar{B} is a system failed state. The equivalent summary Markov model merges the two failed-component states, but the identity of the failure causing component is lost.

A practical system may have K sub-systems and each sub-system has m replaceable or on-site variable components, where K is typically 1, 2 or 3 and m ranges from a few upwards to one hundred. The detailed Markov model would have $2^K \times m$ states, not counting any intermediate states added to model detection, maintenance and repair. This state-space explosion is typically contained by truncation of the Markov model to represent no more than K concurrent failures, and only those combinations of component failure-causing system failure. When component failure rates are orders of magnitude smaller than component failure detection, failure recovery and repair rates, the truncation usually has negligible effect on the accuracy of the model for predicting measures of system reliability.

If a system can suffer two or more concurrent component failures, the repair can occur simultaneously (simultaneous repair). Figure 3 depicts Markov model in the above system (Figure 2 when it is assumed that repairs can be concurrent (this strategy is in fact applicable to fibre optic transmission systems).

- f) the probabilities and the frequencies of the various states.

The limiting state probability of state “ j ” (the long run proportion of time the system spends in state “ j ”) of a Markov model is given by

$$P_j = \lim_{t \rightarrow \infty} t^{-1} \text{ [Total time spent in state “} j \text{” during } (0, t)].$$

The P_{js} factors of a Markov model are calculated using the steady-state equilibrium principle illustrated in Figure 4. As elapsed time grows indefinitely large, an L -state Markov model reaches a condition of equilibrium in which a set of L simultaneous linear equations, one for each state as shown in Figure 4, hold. If the constrain $P_1 + P_2 + \dots + P_L = 1$ is added to the set, then P_{js} can be calculated. However, care must be taken to avoid round-off problems when there are differences among the transition rates of several orders of magnitude.

Once the P_{js} are calculated, the limiting (long-run) frequency of each state “ j ” in a Markov model can be found using the relationship:

$$F_j = \lim_{t \rightarrow \infty} t^{-1} \text{ [Number of visits to state “} j \text{” during } (0, t)]$$

$$= (\theta_1 + \theta_2 + \dots + \theta_m) P_j.$$

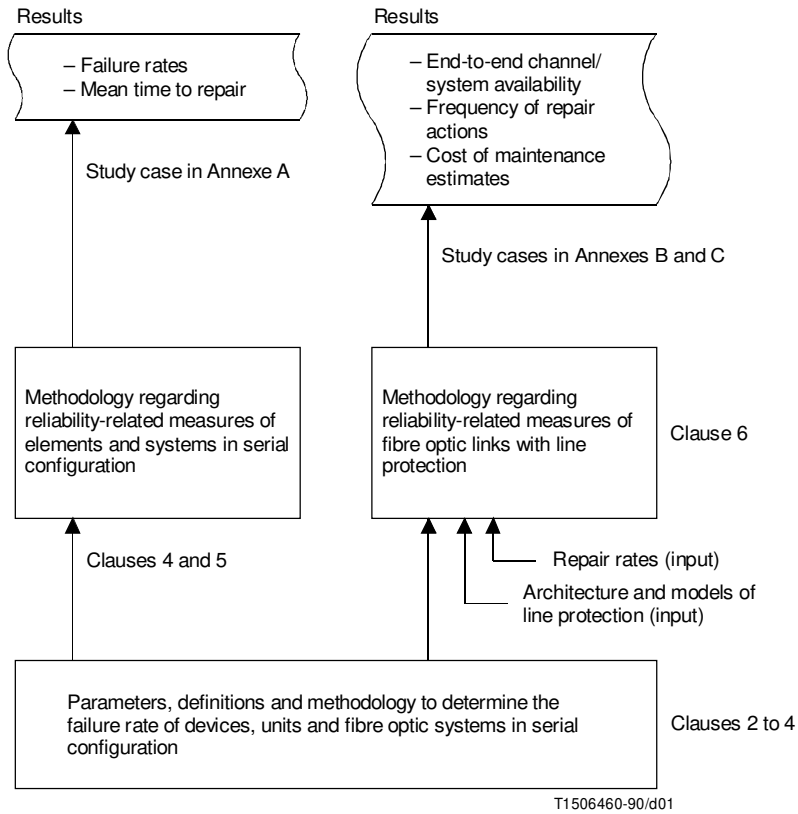

FIGURE 1/G.911
How to use Recommendation G.911

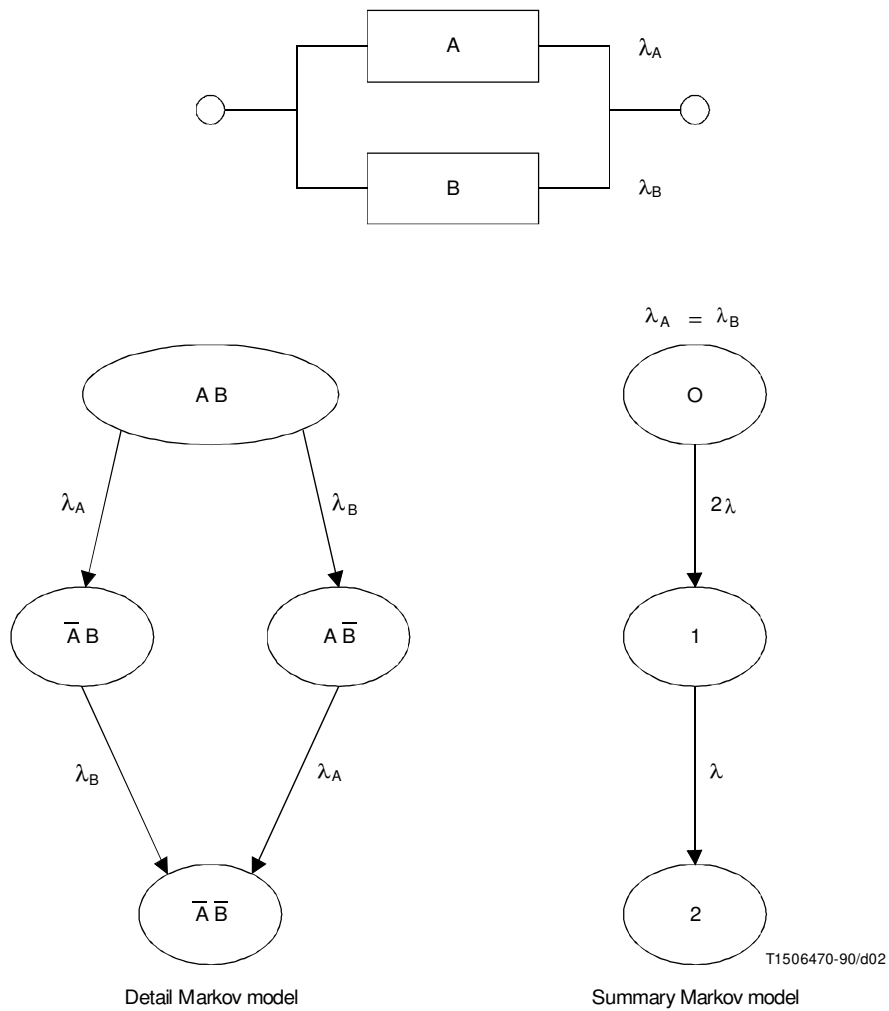
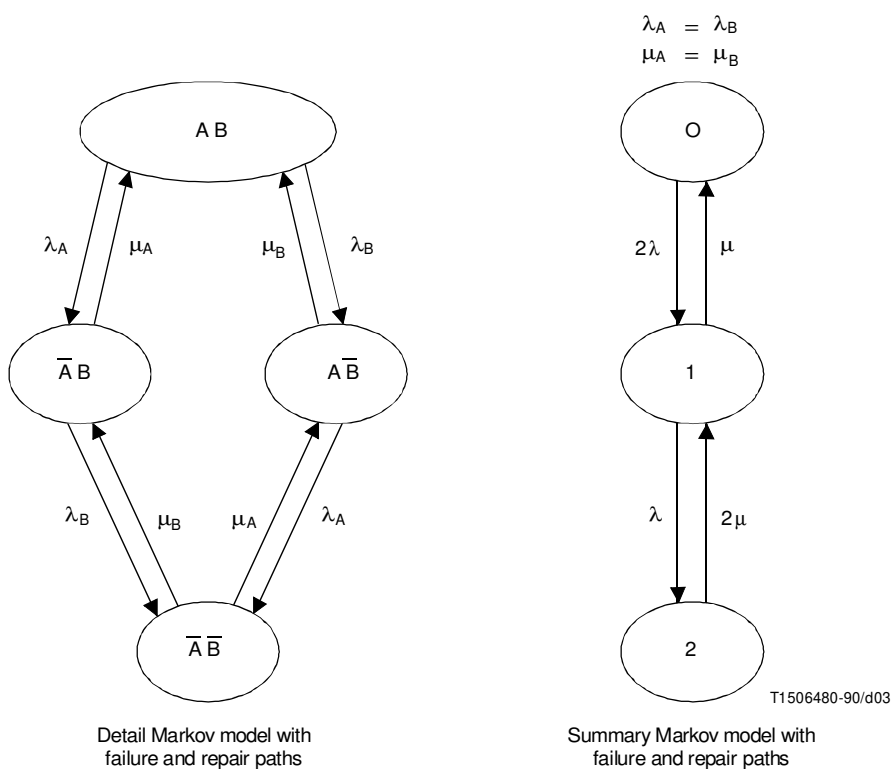
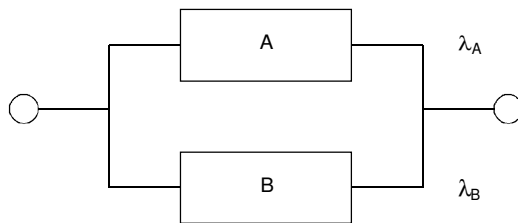

FIGURE 2/G.911
Examples of reliability block diagrams



NOTE – λ stands for failure rates, and μ for repair rates.

FIGURE 3/G.911
Description of Markov model

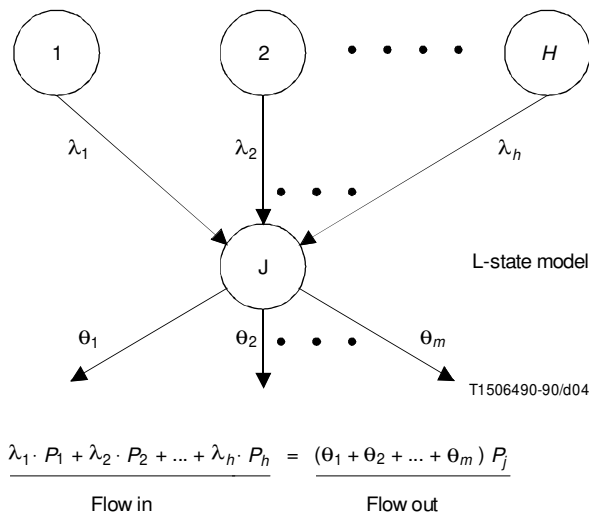

FIGURE 4/G.911
The steady-state equilibrium principle for Markov models

6.2.3 Step 3 – Calculating system reliability-related measures

Once the probabilities and frequencies of the states are calculated, many useful measures of system availability and maintainability can be obtained, with the help of the following expression:

reliability-related measures

$$\text{reliability - related measures} = \sum_j (a_j \times F_j + b_j \times P_j)$$

- g) *Unavailability*: $b_j = 1$ if state “j” is a system failed state, 0 otherwise; $a_j = 0$.
- h) *Frequency of system failure*: $a_j = 1$ if state “j” is a system- failed state, 0 otherwise; $b_j = 0$.
- i) *Downtime per unit time per channel (customer)*: $a_j = 0$; $b_j = N_j/N$ where N_j is number of customers (channels) without service in state “j”, N is the total number of customers (channels).
- j) *Maintenance cost per unit time*: $a_j =$ setup cost for maintenance activity begun in state “j”; $b_j =$ cost per unit time of maintenance activity in state “j”.

6.3 Options of fibre systems with line protection

6.3.1 One-for-one (1 + 1) link protection

This method of protecting a path is simple to provide, control and understand and consequently is widely used.

In its simplest form the traffic from the source is transmitted simultaneously over both bearers and the decision to switch between main and standby is taken at the receiving location; in this situation only “loss of signal” or similar indications are required to initiate changeover and no command and control information needs to be passed between the two sites. After the failed main bearer is repaired and made available for service it is re-designated as the new “standby”. In this way a fault only causes one interruption to customer service and the process of restoration does not introduce a second break.

One-for-one protection gives its best performance if the main and standby routes are completely separated thereby minimizing the risk of common mode failures (see Annex C). Because of the simplicity of this protection technique it can ensure the fastest make-good time with the least need for sophisticated monitoring and control equipment.

On the down-side, one-for-one protection is a very inefficient use of network equipment since 50% is always in a standby mode waiting to be used.

6.3.2 One-for- N ($N + 1$) link protection

This protection technique is an extension of the above technique and addresses the question of inefficient usage of standby equipment. Working on the premise that the failure rate of a route is low enough to ensure that simultaneous failure of two or more routes in a group of N is still highly unlikely, it is possible to share the standby route amongst N working routes (see Annex B).

Compared with one-for-one protection this method makes a more cost-effective use of equipment but requires slightly more sophisticated control and cannot offer the same level of availability. Diverse routing of main and standby paths is also much harder to achieve.

6.3.3 Rings

Ring architectures are sometimes considered to be a class of their own but conceptually the protection offered by a ring can be analysed in terms of one-for-one protection. Whereas one-for-one protection does not immediately imply complete physical diversity between main and standby routes, a ring is usually understood to offer two separate directions of communication.

There are a variety of ring structures each with a range of control/management strategies capable of ensuring autonomous self-healing operation.

The principal advantage of rings is in their flexibility for providing bandwidth at any node on the ring in response to unforeseen demand, thereby overcoming some of the rigid planning rules associated with simpler point-to-point links.

7 Reference circuits for end-to-end channel availability of line systems on optical fibres

A distinction needs to be made between line systems based on the plesiochronous (PDH) and the synchronous (SDH) digital hierarchy standards. SDH equipments provide new flexibility which affects objectives and modelling methods because

- SDH systems may have multiple channel interfaces (e.g. 1.5 Mbit/s, 2 Mbit/s, ..., 155 Mbit/s), compared with only one interface per PDH line system
- SDH products may merge several functions, including digital cross connecting, Add/dropping, and transport into the same SDH network element. On the other hand, digital cross-connect systems and add/drop systems are separate from PDH line terminal.

Therefore, in a SDH-based reference circuit there is no need to allocate unavailability for multiplexing equipments.

The proposed reference circuits (RCs) for end-to-end availability allocation of line systems on optical fibres are shown in diagrams a) and b) of Figure 5. They are applicable to interoffice applications. Concrete numbers for the end-to-end availability may be included into Annexes A, B and C.

The RCs are generic enough to enable a number of repeaters and intermediate offices to be included between end offices. For a given RC length, however, the same unavailability per channel (minutes/year) is recommended for SDH and PDH reference circuits because:

- 1) to allow for a gradual introduction of SDH equipment into a PDH-based network; and
- 2) to assure that the SDH network availability objectives are consistent with the existing PDH network availability objectives.

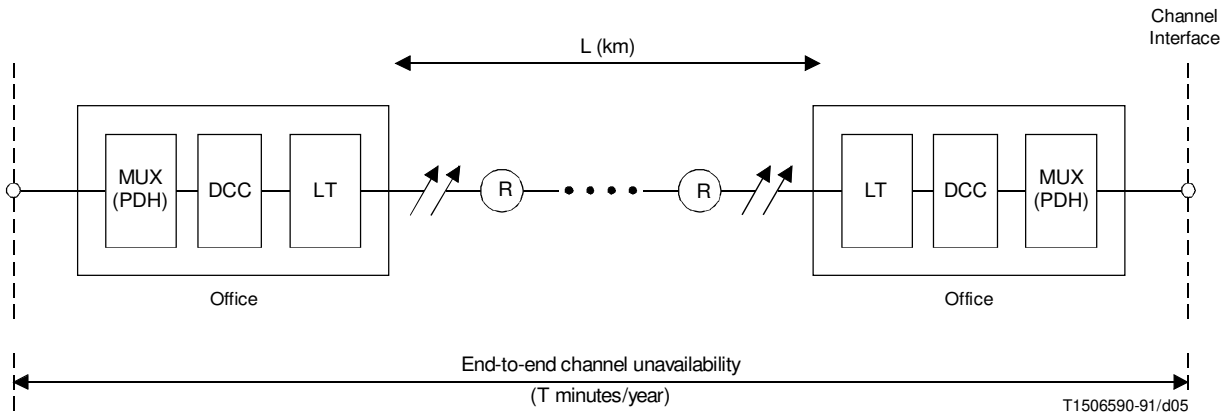

a) Reference circuit for end-to-end channel unavailability in PDH systems in optical fibres

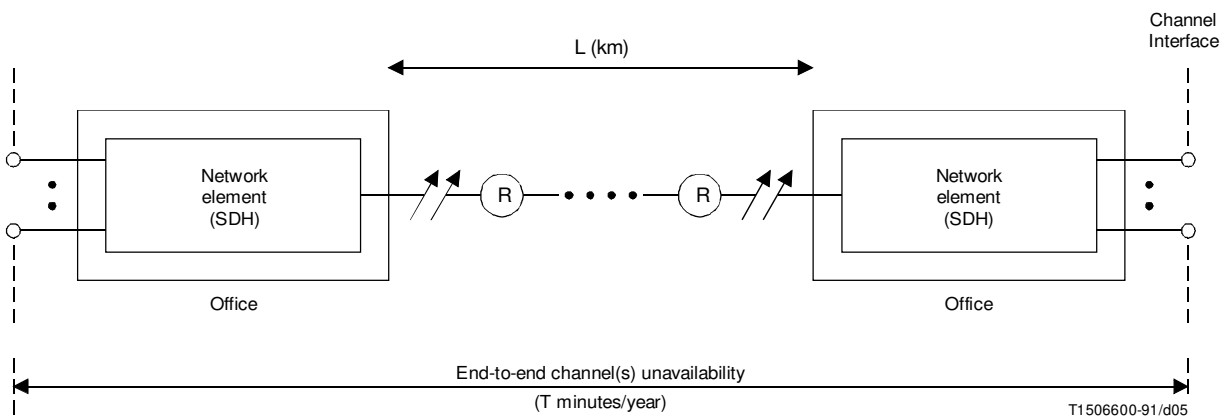

PDH Plesiochronous digital hierarchy

SDH Synchronous digital hierarchy

(R) Repeater

↗↘ Optical fibre

DCC Digital cross-connect

b) Reference circuit for end-to-end channel(s) unavailability in SDH systems

FIGURE 5/G.911
Reference circuit for end-to-end channel unavailability

8 Allocation methodology for end-to-end unavailability objectives

8.1 Contributors to unavailability – Considerations regarding SDH and PDH systems on optical fibres

The factors contributing to the end-to-end channel unavailability include

- a) multiplexers (not applicable to SDH equipment);
- b) optical media (cable, splices, connectors, etc.);
- c) line terminals and repeaters, including allocations for;
 - hardware failures; and
 - software and man-made procedural errors.

Multiplexers – In the SDH systems there is no need for a separate allocation to multiplexing equipments because the SDH standards include a method for mapping channels into the SDH payload.

Optical cables, terminals and repeaters – Up until now, the reported data from telephone operating companies show that the optical media have a greater impact on unavailability than the terminals and repeaters.

Hardware failures and software and man-made procedural errors – SDH systems are more software driven than PDH systems, because:

- the hardware per channel is decreased;
- the amount of software is increased; and
- traffic rearranging is expected to be extensively used.

Therefore it may be sensible to increase the proportion of unavailability allocated to software and procedural errors in SDH than in PDH systems.

8.2 Allocation methodology

Based on the above considerations end-to-end unavailability allocation among relevant contributors are proposed as shown in diagrams a) (PDH systems) and b) (SDH systems) of Figure 6.

The proportion of unavailability allocated to the various contributors is expected to differ for SDH as compared to PDH systems, as shown in Table 8.

TABLE 8/G.911

Unavailability allocation to the various contributors in a reference circuit for end-to-end channel unavailability

Contributing factor	(PDH)	(SDH)	Comment
Multiplexers	Ap	Not applicable	
Cable media	Bp	Bs	Similar values
Terminals and repeaters	Cp	Cs	Similar proportions
Hardware	Dp	Ds	Dp > Ds
Software and procedural	Ep	Es	Ep < Es
T End-to-end channel unavailability (Min/year) A Unavailability proportion (%) allocated to multiplexers B Unavailability proportion (%) allocated to cable C Unavailability proportion (%) allocated to terminals and repeaters D Unavailability proportion (%) allocated to hardware failures E Unavailability proportion (%) allocated to software and man-made procedural errors p Denotes plesochronous digital hierarchy (PDH) systems s Denotes synchronous digital hierarchy systems (SDH) systems			

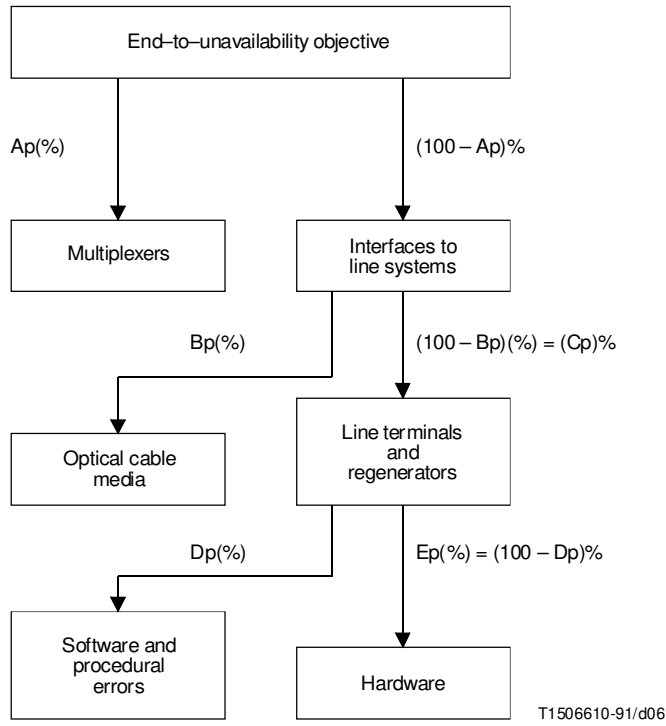

a) End-to-end unavailability allocation methodology – Plesiochronous digital hierarchy systems (PDH)

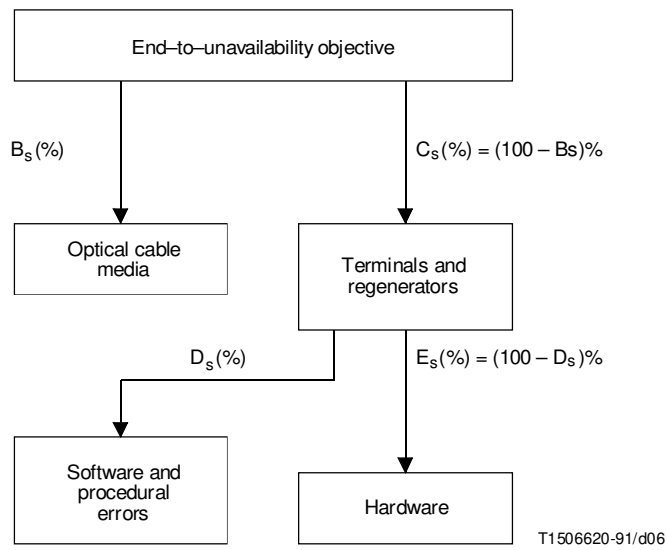

b) End-to-end unavailability allocation methodology – Synchronous digital hierarchy systems (SDH)

FIGURE 6/G.911

End-to-end unavailability allocation methodology

Annex A

Determination of unit steady-state failure rate – Example

(This annex forms an integral part of this Recommendation)

This is an example of the methodology described in 4.3. This example evaluates the unit steady-state failure rate, it does not attempt to suggest any specific reliability objective either for the various devices or for the unit in itself. In this example an environmental failure-rate multiplicative fact (π_e) equal to 2.0 will be employed (see Note 1 of A.3).

A.1 Unit description (example)

Device type	Quantity (N_i)
Laser, 1300 nm	1
Transistor, Si, PNP, ≤ 0.6 W	10
IC, digital, bipolar (hermetic, 30 gates)	8
IC, digital, NMOS (hermetic, 200 gates)	6
Capacitor, discrete, ceramic	6

A.2 Reliability parameters of devices (example)

Device type ($\#i$)	X_{qi} (FITs)	π_{qi}	π_{si}	$\pi_j^{a)}$	$\#i$
Laser, 1300 nm	20 000	0.5	1.0	1.5	1
Transistor, Si, PNP, ≤ 0.6 W	25	1.0	1.0	1.2	2
IC, digital, bipolar (hermetic, 30 gates)	10	1.0	1.0	1.2	3
IC, digital, NMOS (hermetic, 200 gates)	130	1.0	1.0	1.2	4
Capacitor, discrete, ceramic	12	1.0	1.0	1.0	5
a) See Note 2 of A.3.					

A.3 Unit steady-state failure rate (FITs)

Following the procedure described in 4.2 and 4.3, the unit steady-state failure rate is given:

$$\begin{aligned} \lambda_s &= (\pi_e)\{(N_1)(15\ 000) + (N_2)(30) + (N_3)(12) + (N_4)(156) + (N_5)(12)\} \\ &= (2) \times (16\ 404) = 32\ 808 \text{ FITs.} \end{aligned}$$

NOTES

1 This is a typical value for unit to be installed in remote terminal and/or customer premise areas subject to shock and vibration, or temperature and humidity variations. For atmospheric controlled environments (like central offices) a π_e equal to 1.0 is more appropriate.

2 In this example the units operating temperature is assumed to be not higher than 45–50° C.

Annex B

Study case channel availability for a 4×140 Mbit/s repeater link on optical fibres with “3 + 1” line protection

(This annex forms an integral part of this Recommendation)

This is just an example of the methodology described in 6. That example does not attempt to suggest or recommend any specific reliability objective.

B.1 Description

Figure B.1 shows a system in the configuration “ $N + 1$ ”. It consists of N digital line systems on optical fibre operating in parallel with an additional identical reserve system. For the purposes of this case study, the digital line system is made up of a pair of line multiplexer-terminals and by the optical fibre cables with their regenerators. The line systems operate at 565 Mbit/s, made up of four 140 Mbit/s channels.

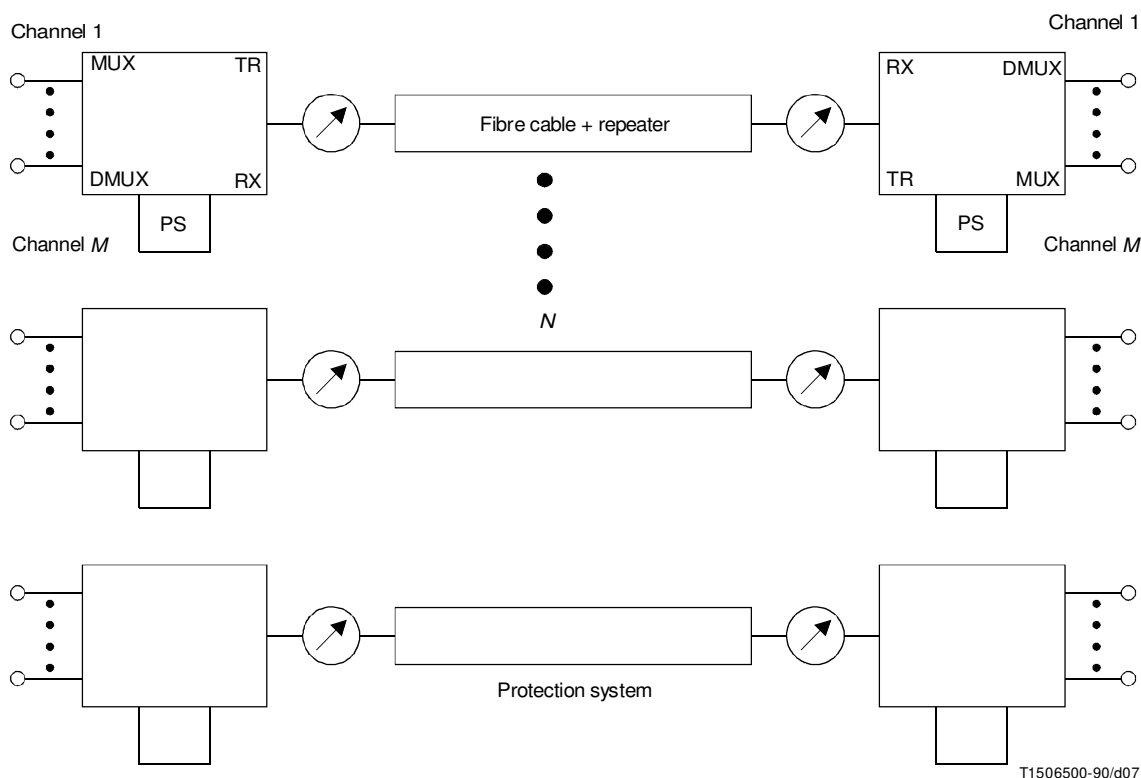
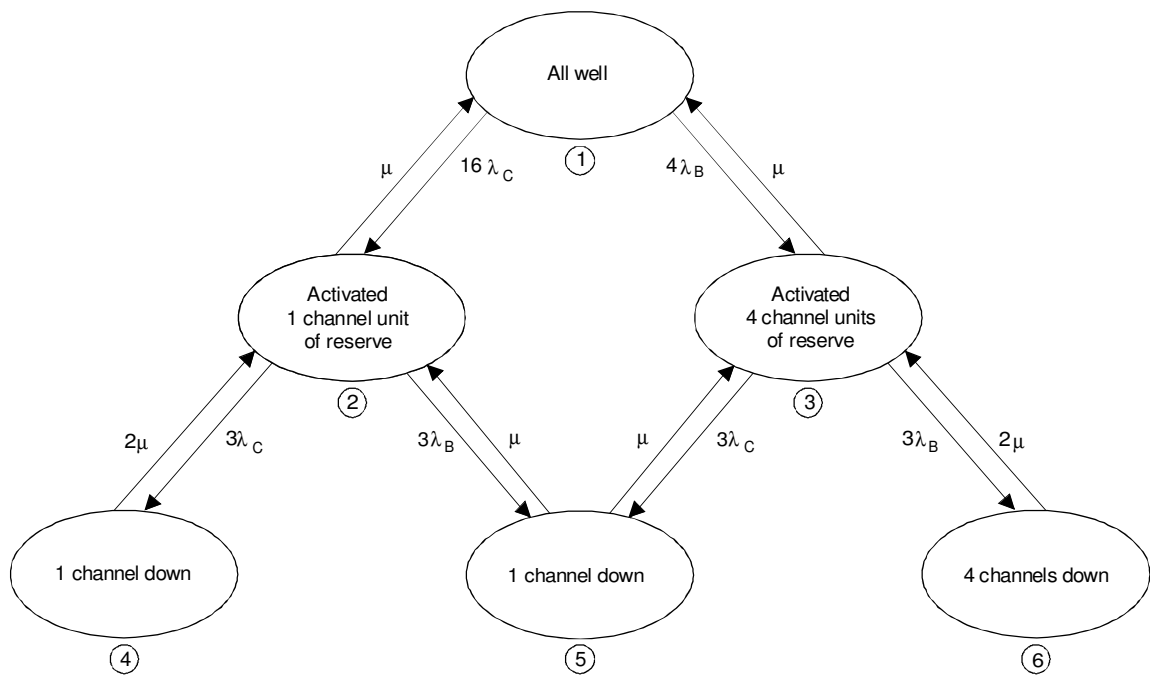

FIGURE B.1/G.911
Example – System configuration “ $N + 1$ ”
 (“ N ” active and 1 reserve)

Figure B.2 shows a diagram of states for the particular case of three active systems ($N = 3$) plus one reserve system. The diagram shows the possible situations which can arise owing to the occurrence of failures in the digital line terminals or in the repeaters.

The reserve system, either partly or wholly, takes over the traffic of any of the line systems in service which breaks down. If the failure occurs in a channel unit (at 140 Mbit/s), then one of the four channel units of the protection system comes into service. If the failure occurs either in the repeaters or in the line multiplexer-terminals, so that a whole system is affected, then the whole of its traffic (four 140 Mbit/s channels) is transferred to the reserve system. If in the case of a failure on a channel or an entire system the traffic cannot be transferred to the reserve system (because it has already taken over the traffic of another faulty system), then the traffic on this channel or system would remain in a state of unavailability.

Figure B.2 also shows the transition from one state to another, according to the failure rate (number of failures per time unit) and repair rate (inverse value of average time taken to repair a failure).



T1 506510-90/d08

- μ Repairs/hour
- λ_C Channel unit failure rate
- λ_B $(\lambda_{MUX} + \lambda_{DMUX} + \lambda_{TX} + \lambda_{RX} + \lambda_{PS}) + \text{No. repeaters} \times (2\lambda_{TX} + 2\lambda_{RX} + \lambda_{PS})$
- TX Optical transmitter
- RX Optical receiver
- PS Power supply unit

Example: $M 4 \cdot (4 \text{ channels of } 140 \text{ Mbit/s per line terminal}) = 16$
 $N (+ 1) = 3 \text{ active } (+ 1 \text{ reserve}) = 3 + 1$

FIGURE B.2/G.911
System configuration “N + 1” – Markov diagram

B.2 Results – Unavailability (minutes/year) per 140 Mbit/s channel

The results given below are based on a “3 + 1” configuration for digital line systems on optical fibre operating at 565 Mbit/s. Unavailability was obtained statistically by estimating the probability of the states which can give rise to the loss of a 140 Mbit/s channel (i.e. states 4, 5 and 6 illustrated in Figure B.2).

Figure B.3 shows unavailability per 140 Mbit/s channel according to:

- repair time per failure;
- number of repeaters in the system.

The results were based on the following failure rates:

- failure rate per channel unit (140 Mbit/s) = 6 000 FITs;
- failure rate of line multiplexer-terminal (without counting channel units) = 42 000 FITs;
- failure rate per regenerator = 42 000 FITs.

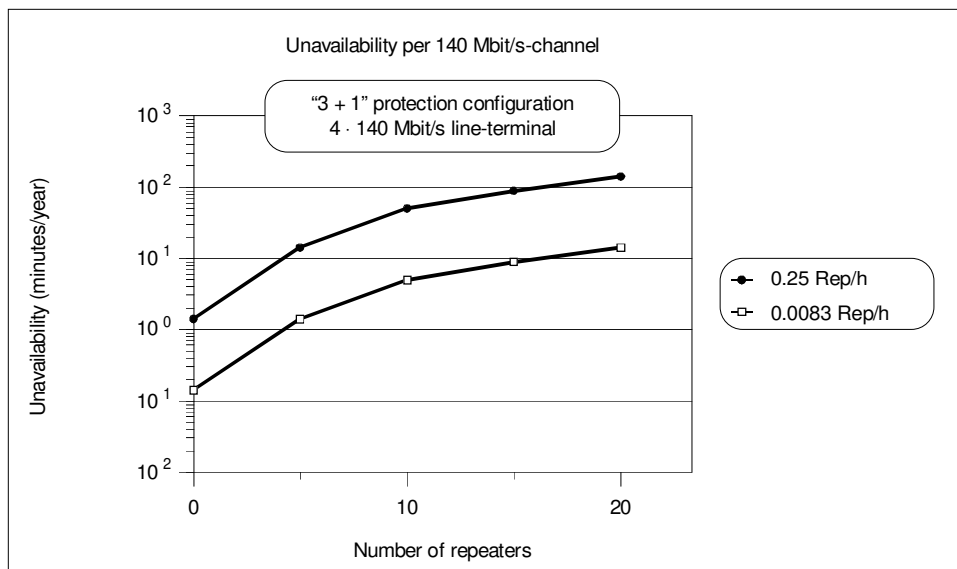

T1506520-90/d09

FIGURE B.3/G.911
Unavailability for 140 Mbit/s-channel

Annex C

Study case – Channel availability for a point-to-point fibre connection in the local network with “1 + 1” line protection, with and without cable-path redundancy

(This annex forms an integral part of this Recommendation)

This is an example of the methodology described in 6. That example does not attempt to suggest or recommend any specific reliability objective.

C.1 Description

C.1.1 Nature of the problem

The widespread deployment of optical fibres in the telecommunication networks and the increasing traffic carried on individual fibres have raised concerns about the need for line terminals and cable redundancy to reduce service interruptions in the event of cable cut or line equipment failure. In the access network this is even more critical because users do not have alternate path connections via another central office (as it may be the case in connection among central offices).

These approaches are motivated by practical considerations. For instance, banks and brokerage firms have a very high priority for network reliability. Even in the current narrow-band environment, these businesses may have dual 1 : 1 protection via the same path or alternate path for many of their connection links. This provides one-for-one backup links, with automatic or handy switchover to a backup link when a link failure occurs. In a broadband environment, when a cable cut might eliminate multiple 155 Mbit/s communication lines, these concerns would probably be even higher.

This annex describes and evaluates the reliability issues and the impact on customer connection availability for the following five types of connections (see 1.2):

- connections with no redundancy;
- connections with line equipment redundancy and manual switchover;
- connections with line equipment redundancy and automatic switchover;
- connections with cable redundancy; and
- connections with line equipment and cable redundancy.

C.1.2 Type of connections

The connections between central office (CO) and customer premises (CP) are implemented with single-mode fibres. Each fibre is used for unidirectional transmission, thereby requiring the deployment of fibres in pairs to achieve duplex connections. The equipment-redundancy approach assumes 1 : 1 protection for optical line terminating multiplexers (OLTMs). Cable redundancy assumes an alternate path is provided via a physically diverse route. Manual switching assumes that there is a certain time, between the failure and switch, in which the connection is unavailable, and, in the automatic switching, this time is 0.

The five alternative connection approaches are:

- Connections with no redundancy [Figure C.1a].
- Connections with line equipment redundancy and manual switchover [Figure C.1b)]. The design provides protection against terminal equipment failure at the CO and CP. However, the system is vulnerable to fibre cable failure. Switching time is considered.
- Connections with line equipment redundancy and automatic switchover [Figure C.1c)]. This is the same case as before but the switching time is 0.
- Connections with cable redundancy (Figure C.1d). This alternative assumes that working and protection fibres follow physically separate paths to the same CO. This design provides protection against fibre cable failures. The fibre cable switching is automatic.
- Connections with line equipment and cable redundancy [Figure C.1e)]. This design provides protection against terminal equipment failure and fibre cable failures. This alternative is divided in two: (e1) with automatic switchover and (e2) without automatic switchover.

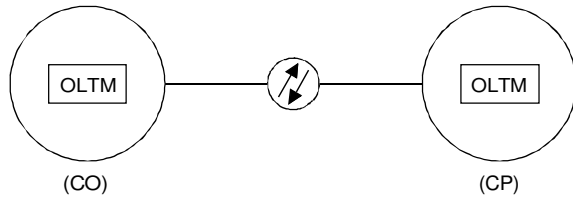

a) No redundancy

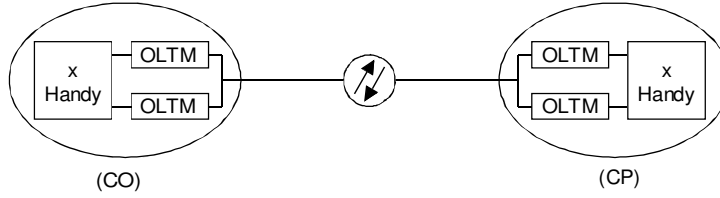

b) Connection with terminal equipment redundancy and manual switchover

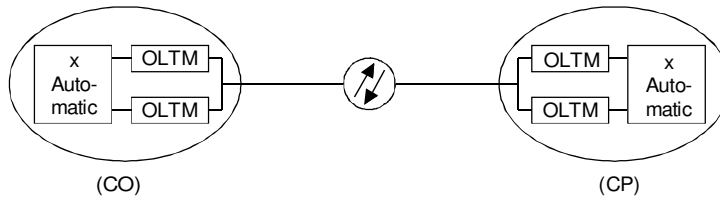

c) Connection with terminal equipment redundancy and automatic switchover

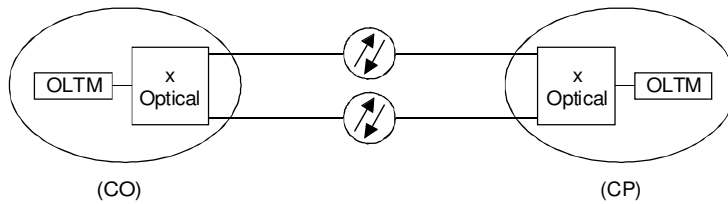

d) Connection with cable redundancy

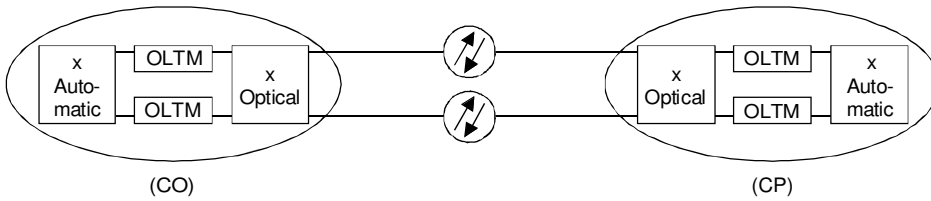

e1) Connection with terminal equipment and cable redundancy and automatic switchover

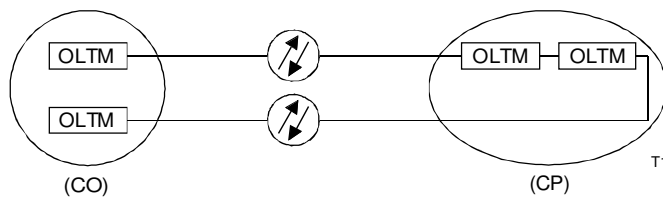

e2) Connection with line - Equipment and cable redundancy

T1506630-91/d10

FIGURE C.1/G.911
Type of corrections considered

C.2 Results

To quantify and compare the reliability performance of the five connection approaches described above, this clause provides the unavailability (in minutes per year per 2 Mbit/s channel), based on Markov models.

Figure C.2 considers the unprotected system. The system is inoperative if any of the two network elements has a failure.

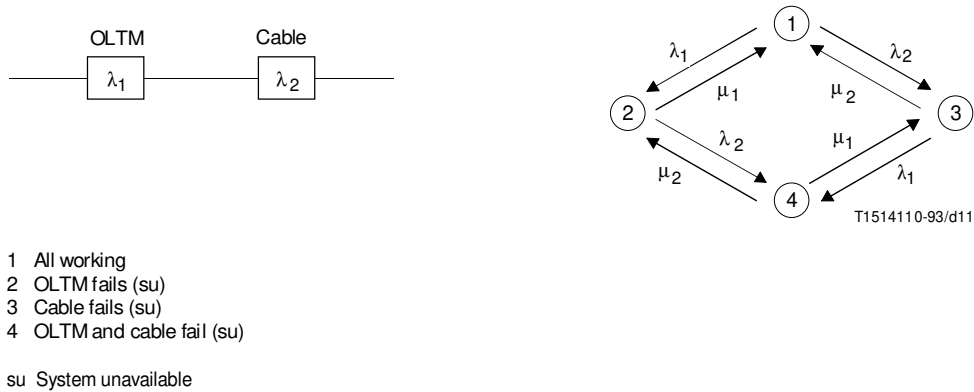

FIGURE C.2/G.911
No redundancy and its Markov model

Figure C.3 shows the OLTMs redundancy approach and manual switchover. In the normal operating state (1), both the working and the protection terminal equipment at the CO and CP are fully operational. When one of the two units has a failure (state 2), the other unit takes over manually in a determinate time during which the system is inoperative. The system can be restored to state 1 if the switch is done. The system is also inoperative (state 3) if both units fail or the cable loop between CO and CP fails.

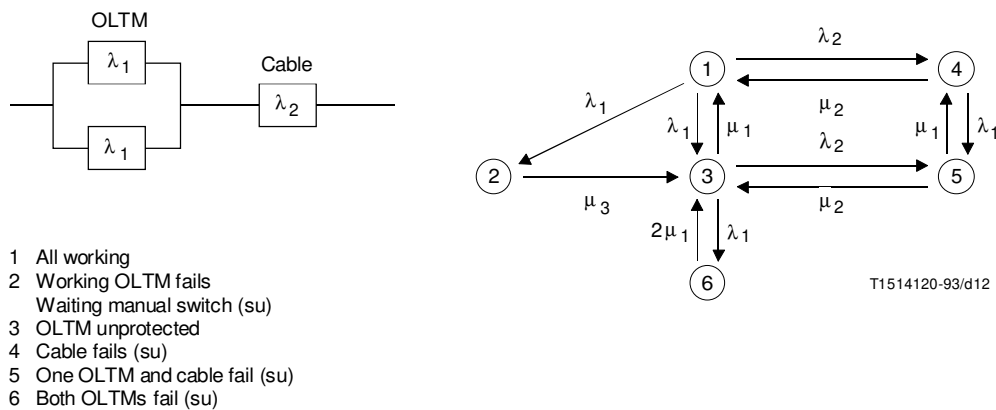

FIGURE C.3/G.911
Connection with terminal equipment redundancy and manual switchover and its Markov model

Figure C.4 shows the OLTMs redundancy approach and automatic switchover. In the normal operating state (1), both the working and the protection terminal equipment at the CO and CP are fully operational. When one of the two units has a failure (state 2), the other unit automatically takes over and provides continuous operation. The system can be restored to state 1 if the unit is restored. The system is inoperative (state 3) if both units fail, or the cable loop between CO and CP fails.

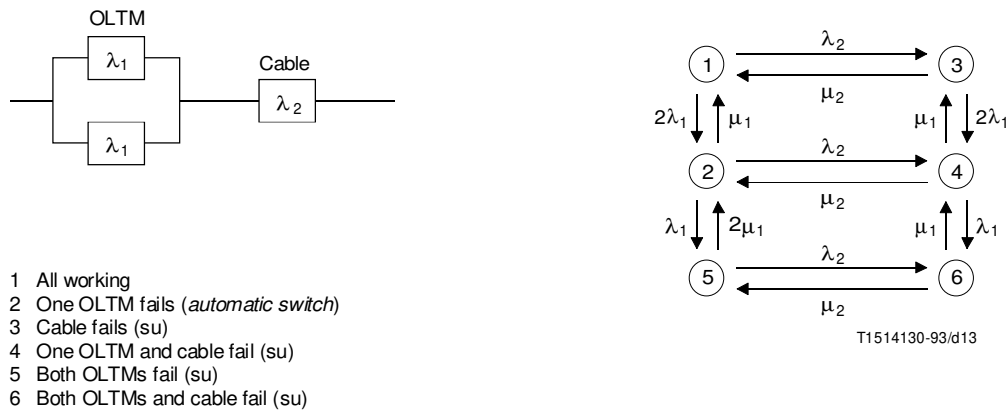

FIGURE C.4/G.911
Connection with terminal equipment redundancy and automatic switchover and its Markov model

Figure C.5 shows the cable redundancy approach. In the normal operating state (1), both cables are fully operational. When one of the two cables has a failure (state 2), the other cable automatically takes over and provides continuous operation. The system can be restored to state 1 if the cable is restored. The system is inoperative (state 3) if both cables fail or the terminal equipment between CO and CP fails.

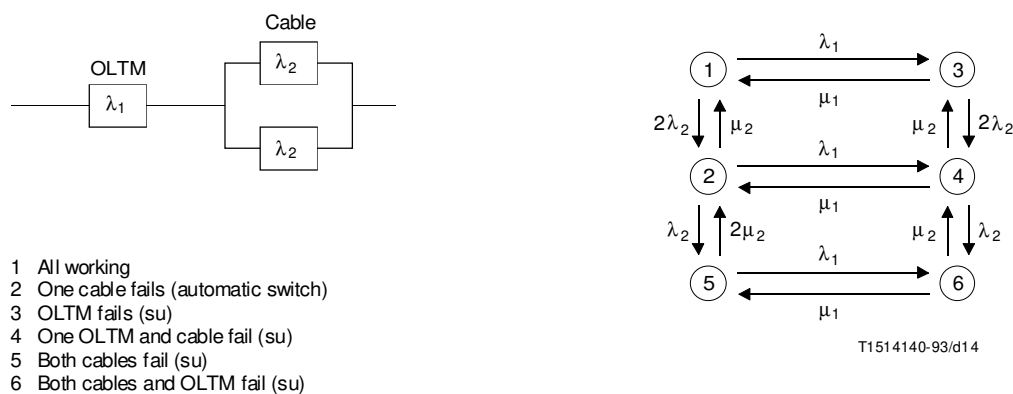
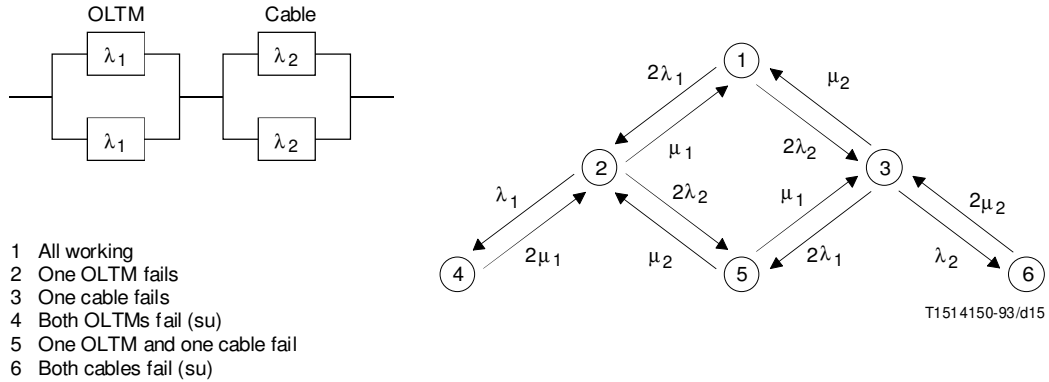

FIGURE C.5/G.911
Connection with cable redundancy and its Markov model

Figure C.6a shows the terminal equipment and cable redundancy approach. In normal operation both working and protection equipment and cable are fully operational. State 2 depicts those situations in which one OLTM or one cable loop fails. The other unit automatically takes over and provides continuous operation. The system can be restored to state 1 if the fail is restored. The system is inoperative (state 3) if both cables or both OLTMs fail.

Figure C.6b) shows the OLTMs and cable redundancy approach. In normal operation both working and protection equipment and cable are fully operational. States 2 and 3 depict those situations in which one OLTM or one cable loop fails, respectively. State 4 refers to the situations in which both an OLTM and one cable loop fails, however, those faults being placed in different paths. The system is inoperative in state 5.



NOTE – These groups do not represent all possible situations.

FIGURE C.6a)/G.911

Connection with terminal equipment and cable redundancy and automatic switchover and its Markov model

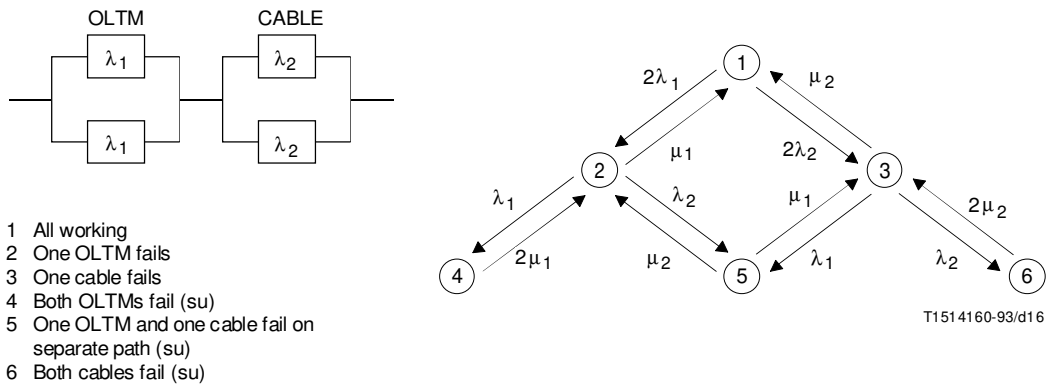

NOTE – These groups do not represent all possible situations.

FIGURE C.6b)/G.911

Connection with cable and OLTM redundancy and its Markov model

Table C.1 shows the list of steady-state failure rates, repair rates and handy switching times.

TABLE C.1/G.911

Steady-state failure rates, repair rates and handy switching times

Steady-state failure rate of OLTM (λ_1)	23 000-57 000 FITs; MTBF = 2-5 years
Steady-state failure rate of cable (λ_2)	11 500-23 000 FITs; MTBF = 5-10 years
Repair rate of OLTM (μ_1)	(1-2 per day)
Repair rate of cable (μ_2)	(0.5-1 per day)
Manual switching time ($1/\mu_3$)	(0.5-4 hours)

Tables C.2 to C.6 lists the results of the different cases.

TABLE C.2/G.911

Performance of unprotected broadband customer local – Connections

$(1/\lambda_1)$ years	$(1/\lambda_2)$ years	$(1/\mu_1)$ days	$(1/\mu_2)$ days	2 Mbit/s channel unavailability (minutes/year)
2	5	0.5	1	647
2	10	0.5	1	504
5	5	0.5	1	432
5	10	0.5	1	289
2	5	1	2	1294
2	10	1	2	1006
5	5	1	2	863
5	10	1	2	576

TABLE C.3/G.911

**Performance of customer access connection with terminal equipment
redundancy and manual switchover**

$(1/\lambda_1)$ years	$(1/\lambda_2)$ years	$(1/\mu_1)$ days	$(1/\mu_2)$ days	$(1/\mu_1)$ hours	2 Mbit/s channel unavailability (minutes/years)
2	5	0.5	1	0.5	303
2	10	0.5	1	0.5	159
5	5	0.5	1	0.5	294
5	10	0.5	1	0.5	150
2	5	1	2	0.5	591
2	10	1	2	0.5	304
5	5	1	2	0.5	582
5	10	1	2	0.5	294
2	5	0.5	1	1	318
2	10	0.5	1	1	174
5	5	0.5	1	1	300
5	10	0.5	1	1	156
2	5	1	2	1	606
2	10	1	2	1	319
5	5	1	2	1	587
5	10	1	2	1	300

TABLE C.4/G.911

**Performance of customer access connection with terminal equipment
redundancy and manual switchover**

$(1/\lambda_1)$ years	$(1/\lambda_2)$ years	$(1/\mu_1)$ days	$(1/\mu_2)$ days	2 Mbit/s channel unavailability (minutes/year)
2	5	0.5	1	288
2	10	0.5	1	144
5	5	0.5	1	288
5	10	0.5	1	144
2	5	1	2	576
2	10	1	2	289
5	5	1	2	576
5	10	1	2	288

TABLE C.5/G.911

Performance of customer access connection with cable redundancy

$(1/\lambda_1)$ years	$(1/\lambda_2)$ years	$(1/\mu_1)$ days	$(1/\mu_2)$ days	2 Mbit/s channel unavailability (minutes/year)
2	5	0.5	1	360
2	10	0.5	1	360
5	5	0.5	1	144
5	10	0.5	1	144
2	5	1	2	720
2	10	1	2	719
5	5	1	2	288
5	10	1	2	288

TABLE C.6/G.911

Performance of customer access**a) Performance of customer access connection with terminal equipment and cable redundancy and automatic switchover**

$(1/\lambda_1)$ years	$(1/\lambda_2)$ years	$(1/\mu_1)$ days	$(1/\mu_2)$ days	2 Mbit/s channel unavailability (minutes/year)
2	5	0.5	1	0.40
2	10	0.5	1	0.29
5	5	0.5	1	0.20
5	10	0.5	1	0.08
2	5	1	2	1.61
2	10	1	2	1.14
5	5	1	2	0.79
5	10	1	2	0.31

b) Performance of customer access connection with cable and terminal equipment redundancy

$(1/\lambda_1)$ years	$(1/\lambda_2)$ years	$(1/\mu_1)$ days	$(1/\mu_2)$ days	2 Mbit/s channel unavailability (minutes/year)
2	5	0.5	1	0.80
2	10	0.5	1	0.48
5	5	0.5	1	0.35
5	10	0.5	1	0.16
2	5	1	2	3.18
2	10	1	2	1.92
5	5	1	2	1.42
5	10	1	2	0.63