



INTERNATIONAL TELECOMMUNICATION UNION

ITU-T

TELECOMMUNICATION
STANDARDIZATION SECTOR
OF ITU

G.101

(03/93)

**TRANSMISSION SYSTEMS AND MEDIA
GENERAL CHARACTERISTICS OF INTERNATIONAL
TELEPHONE CONNECTIONS AND INTERNATIONAL
TELEPHONE CIRCUITS**

THE TRANSMISSION PLAN

ITU-T Recommendation G.101

(Previously "CCITT Recommendation")

FOREWORD

The ITU Telecommunication Standardization Sector (ITU-T) is a permanent organ of the International Telecommunication Union. The ITU-T is responsible for studying technical, operating and tariff questions and issuing Recommendations on them with a view to standardizing telecommunications on a worldwide basis.

The World Telecommunication Standardization Conference (WTSC), which meets every four years, established the topics for study by the ITU-T Study Groups which, in their turn, produce Recommendations on these topics.

ITU-T Recommendation G.101 was revised by the ITU-T Study Group XII (1988-1993) and was approved by the WTSC (Helsinki, March 1-12, 1993).

NOTES

1 As a consequence of a reform process within the International Telecommunication Union (ITU), the CCITT ceased to exist as of 28 February 1993. In its place, the ITU Telecommunication Standardization Sector (ITU-T) was created as of 1 March 1993. Similarly, in this reform process, the CCIR and the IFRB have been replaced by the Radiocommunication Sector.

In order not to delay publication of this Recommendation, no change has been made in the text to references containing the acronyms "CCITT, CCIR or IFRB" or their associated entities such as Plenary Assembly, Secretariat, etc. Future editions of this Recommendation will contain the proper terminology related to the new ITU structure.

2 In this Recommendation, the expression "Administration" is used for conciseness to indicate both a telecommunication administration and a recognized operating agency.

© ITU 1994

All rights reserved. No part of this publication may be reproduced or utilized in any form or by any means, electronic or mechanical, including photocopying and microfilm, without permission in writing from the ITU.

CONTENTS

		<i>Page</i>
1	Principles	1
2	Definitions and conventions.....	1
2.1	Circuits and connections.....	1
2.5	Power handling capacity.....	4
2.6	Relation between send loudness ratings and relative levels.....	4
2.7	Determination of relative level.....	5
2.8	Relative level of a point in a digital link	5
2.9	PCM Digital Reference Sequence (DRS)	6
2.13	Relative levels specified in the Virtual International Connecting Points	9
2.15	Measurement frequency.....	11
3	Number of circuits in a connection.....	11
3.1	National circuits	11
3.2	International circuits	11
3.3	Hypothetical reference connections.....	12
3.4	Number of circuits encountered in an international connection	12
4	Incorporation of unintegrated digital processes	12
4.1	General	12
4.2	Types of telephone circuits	16
4.3	Number of unintegrated PCM digital processes.....	18
4.4	Transmission of analogue and digital data	19
4.5	General principle	19
Annex A	– The concepts of relative levels, dBm ₀ , circuits and connections, and their use in transmission planning.....	19
A.1	Introduction	19
A.2	Circuits and connections.....	19
A.3	Relative levels.....	20
A.4	Digital pads and the designation of relative levels	20
A.5	Level jumps	21
A.6	Power handling capacity.....	21
A.7	Examples	22
References	25

THE TRANSMISSION PLAN¹⁾

(Geneva, 1964; amended at Mar del Plata, 1968, Geneva, 1972, 1976 and 1980;
Malaga-Torremolinos, 1984 and Helsinki, 1993)

1 Principles

The transmission plan established in 1964 was drawn up with the object of making use, in the international service, of the advantages offered by 4-wire switching. It is referred to in the Recommendations appearing in Part I, section 1 of the G-Series Recommendations. However, the Recommendations in the plan are to be considered as met if the use of technical means other than those described below gives an equivalent performance at the international exchange.

Recommendations G.121 and G.122 describe the conditions to be fulfilled by a national network for this transmission plan to be put into effect.

NOTES

1 From the point of view of the transmission plan, no distinction is made between intercontinental circuits and other international circuits.

2 Short trans-frontier circuits are not covered by this plan and should be the subject of agreement between the Administrations concerned.

2 Definitions and conventions

2.1 Circuits and connections

telephone circuit: In transmission planning, and in the G-Series Recommendations, a telephone circuit denotes a telecommunication circuit with associated terminating equipment, directly connecting two switching devices or exchanges, in line with Note 2 to the general definition of a circuit, (see 1.4/G.100). For simplicity, the term “circuit” is often used instead of “telephone circuit” in the G-Series Recommendations.

NOTES

1 Conceptually, (telephone) circuits are those parts of the connections that remain intact and permanently associated with the switches at each end, after a connection is taken down and before a new connection is established. Routine measurements of (telephone) circuits are made in a way approaching the ideal concept as closely as possible, i.e. between circuit access points which between them will include as much of the (telephone) circuit as possible (see 2.1.2./M.565).

2 In some cases, mainly in private networks, the definition of circuit is not applicable. Exchanges within a private network are normally interconnected via leased lines, specified at the interfaces of the transmission systems.

Subscriber’s (telephone) line; subscriber’s loop (in telephony): A link between a public switching entity and a telephone station or a private telephone installation or another terminal using signals compatible with the telephone network.

NOTE – In French, the term “ligne de réseau” is used only when the private telephone installation is a private branch exchange or an internal telephone system.

local (telephone) system; local (telephone) circuit: The combination of subscriber’s station, subscriber’s line and feeding bridge if present, see Figure 1. (See also Recommendation P.10, term 31.02.)

NOTES

1 This term is used in the context of transmission planning and performance.

2 In CCITT English texts, the term “local” (telephone) system is preferred.

3 A local network includes the local system, the local exchanges and interconnecting circuits.

¹⁾ This Recommendation is partly reproduced in Recommendations Q.40, Q.43 and M.560.

subscriber system (in transmission planning): A subscriber's line associated with that part of the private telephone installation connected to this line during a telephone call, see Figure 1 (see also Recommendation P.10, term 31.03).

NOTE – This term is used in the context of transmission planning and performance.

subscriber circuit: The circuit between the local exchange and the Network Connection Point (NCP), i.e. the interface between the public network and the subscriber's installation, see Figure 1. This interface may for instance be at the MDF of a PBX, at a socket for connecting a telephone set, etc. The location of this interface is dependent on national regulations and practice.

NOTE – In the local exchange the subscriber circuit usually includes "half" of the exchange in an analogue exchange and in a digital exchange the input and output of the circuit usually will be a digital bit stream corresponding to the "exchange test points" defined in 1.2.1.1/Q.551.

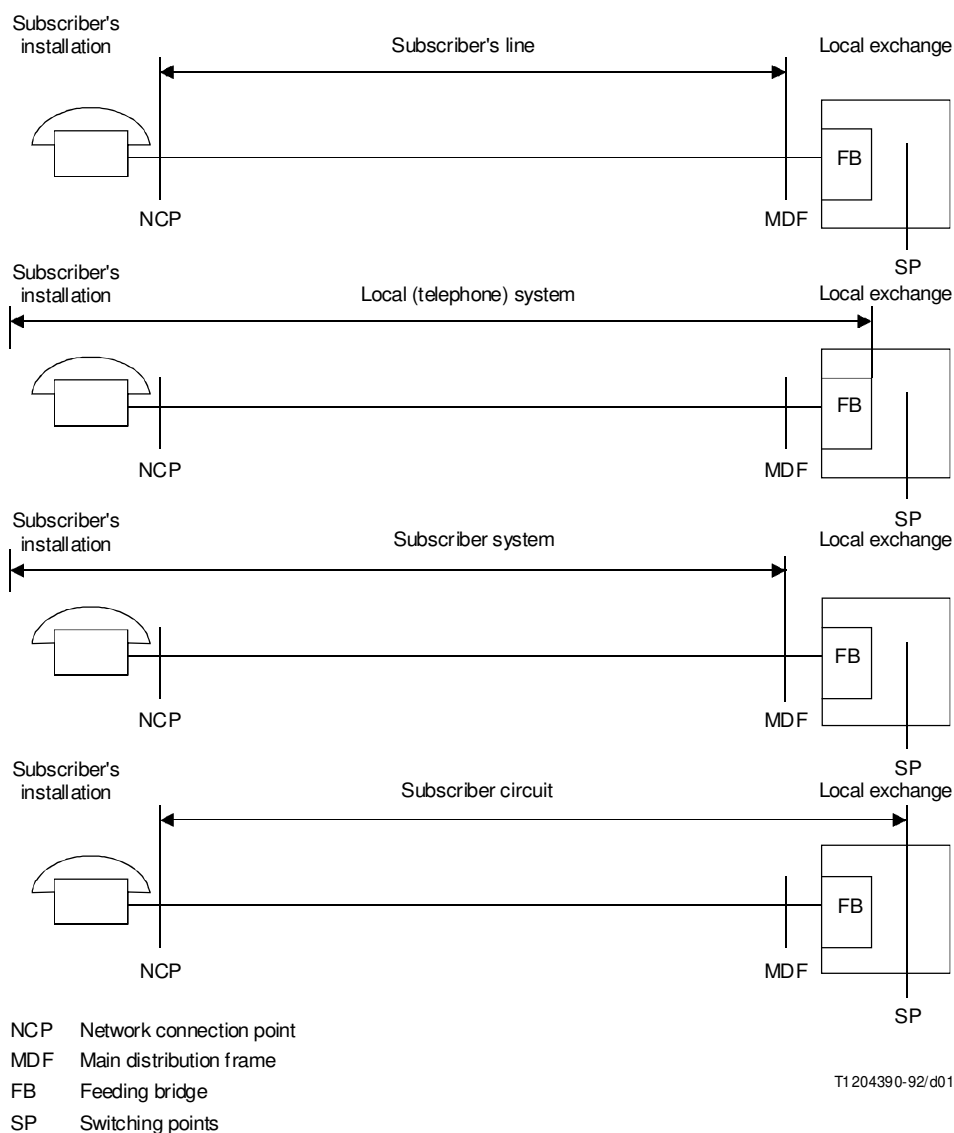

FIGURE 1/G.101
**Subscriber's line, local (telephone) system,
 subscriber system and subscriber circuit**

telephone circuit loss: This is the composite loss at the reference frequency 1020 Hz between the circuit input and its output, as defined in Note 1. This will include any loss in the associated terminating equipment of the switching centres.

NOTES

1 Defined for transmission planning purposes, the input and output of a circuit are hypothetical points in an exchange where circuits are directly interconnected (see 2.3.3/M.560) and are consequently not accessible, e.g. for measurement purposes. To enable the necessary correlation to be made between planning and measured values, “circuit access points” are defined in Recommendation M.565; their relation to the circuit input and output are shown in Figures 1a and 1b/M.565 for analogue and digital exchanges, respectively. After carrying out the measurement between these points, any necessary correction is made for the effect of circuit access arrangements to allow circuit loss to be determined (see 3.1.2/O.22).

2 For digital exchanges it will be seen that the circuit input and output correspond to the “exchange test points” as defined in 1.2.1.1/Q.551). Since the levels at these points are defined in terms of the digital bit streams appearing there, neither digital access arrangements nor passage through the digital switchblock will involve any loss or gain, provided the bit sequence is not affected. On the other hand any recoding, for example such as produced by a “digital pad”, will be included in the circuit loss. To allow at least the mandatory alternative of “bit-transparent” connections (i.e. retaining bit integrity, see 3.1.2/Q.554), the “pad” function must be switchable, i.e. it must be possible:

- a) to make measurements under conditions which simulate at will each real traffic condition requiring a different pad value;
- b) to check the bit error ratio (see 3.1.1/Q.554), which of course needs to be done in the absence of intentional changes in the bit stream.

3 For analogue exchanges the assumption is made that nominal switchblock losses (defined in 3.2/Q.45) are divided equally between the two circuits being interconnected in the exchange. The variance of switchblock losses contributes negligibly to the variance of circuit loss by comparison with the objective for loss variations in transmission systems (see 1.1.2/M.160).

4 The circuit access points are not to be confused with the “line access points”, usually located at a distribution frame (see Recommendation M.120, last paragraph). These points are not of interest for transmission planning, but only for the maintenance services for line-up and fault localization purposes.

5 The input and output of international circuits are defined as the Virtual International Connecting Points having defined relative levels (see 2.12). This is necessary to have a defined boundary between the national and international parts of a connection.

connection: A chain of circuits interconnected by switching points, between two different points in the network.

In transmission planning the loss of a connection is normally the sum of the losses of the circuits making up the connection. (The losses of the switching centres are normally included in the circuit losses.)

NOTES

1 A complete connection is a connection between two terminal equipment connected to the network.

2 When analogue or mixed analogue/digital circuits are interconnected in the exchanges, “level jumps” often have to be introduced. In a complete connection, the sum of all “level jumps” and digital losses should not exceed 3 dB in the short term and 6 dB in the long term.

2.2 transmission reference point (TRP): A hypothetical point used as the zero relative level point to define the concept of relative levels. When specifying and measuring equipment, transmission systems, exchanges and PBXs etc., the term “Level Reference Point (LRP)” is often used instead of transmission reference point.

2.3 relative (power level): The relative level at a point on a circuit is given by the expression $10 \log_{10} (P/P_0)$ dBr, where P represents the apparent power of a sinusoidal test signal at the reference frequency 1020 Hz at the point concerned and P_0 the apparent power of that signal at the transmission reference point. This is numerically equal to the composite gain between the transmission reference point and the point concerned (or the composite loss between the point concerned and the transmission reference point), for the reference frequency 1020 Hz. For example, if a 1020 Hz signal having a level of x dBm is injected at a point in the circuit and the level measured at the transmission reference point is 0 dBm, the relative level at the point is x dBr. If y dBm is measured at another point in the circuit, the relative level at that point is y dBr.

NOTES

1 The definition above is generally applicable to all systems, e.g. digital exchanges, transmission systems and other types of switching and transmission equipment. It should be noted that these network components often have specified relative levels at their interfaces. These relative levels may differ from the relative levels of a circuit at the same interfaces.

2 In transmission planning, each circuit will have its own specific transmission reference point.

3 The nominal reference frequency of 1020 Hz is in accordance with Recommendation O.6. For existing wholly analogue circuits, one may continue to use a reference frequency of 800 Hz.

4 The relative levels at particular points in a transmission system (e.g. input and output of distribution frames or of equipment like channel translators) are fixed by convention, either by Recommendations or by agreement between manufacturers and users.

5 In real life, the relative levels of different points in a circuit will be determined based on the fixed relative levels at the input and output of transmission systems or digital exchanges.

6 The applications of relative levels and related concepts are described in Annex A.

2.4 dBm0: At the reference frequency (1020 Hz), L dBm0 represents an absolute power level of L dBm measured at the transmission reference point (0 dBr point), and a level of $L + x$ dBm measured at a point having a relative level of x dBr.

The voltage of an 0 dBm0 tone at any voice-band frequency at a point of x dBr is given by the expression:

$$V = \sqrt{10^{x/10} \cdot 1 \text{ W} \cdot 10^{-3} \cdot |Z_{1020}|} \quad \text{volts}$$

where $|Z_{1020}|$ is the modulus of the nominal impedance, Z , at the point at the reference frequency 1020 Hz. Z may be resistive or complex.

2.5 Power handling capacity

FDM transmission systems (excepting the cases mentioned in Note 2) are designed for a nominal mean power during the busy hour of -15 dBm0 per channel. This is the mean with time and the mean of a large bunch of circuits. (See Recommendation G.223.) This corresponds to a mean active speech level (pauses in the speech not included) of -11 Bm0. This relation does not take account of the transmission of non-voice services. Many clauses for such services are based on the assumption of a limit of -13 dBm0 on the 1-minute mean power (see for instance 2.3 i)/V.2 for modem data; clause 1/H.31 and clause 5/H.34 for subdivided telephone-type channels, etc. A generalized Recommendation in this sense is under study.

In PCM encoding/decoding processes one has a maximum level T_{max} of 3.14 dBm0 for A-law and 3.17 dBm0 for μ -law (see Recommendation G.711). In each channel, sinusoidal signals having levels above T_{max} will be clipped.

NOTES

1 The relative levels of the circuit should be chosen to give the best possible loading of the transmission systems, i.e. to give a mean active speech level of -11 dBm0 in FDM systems and control peak levels in PCM systems to avoid unacceptable clipping.

2 The mean active speech level of -11 dBm0 is calculated on the assumption that the activity factor is 0.25. For certain systems, e.g. submarine cable systems (see Recommendation G.371) and DCME systems, other values apply.

2.6 Relation between send loudness ratings and relative levels

The relationship between the 0 dBr point and the level of T_{max} in PCM encoding/decoding processes standardized by the CCITT is set forth in Recommendation G.711. In particular, if the minimum nominal send loudness rating (SLR) of local systems referred to a point of 0 dBr of a PCM encoder is not less than +2 dB and the value of T_{max} of the process is set at +3 dBm0 (more accurately 3.14 dBm0 for A-law and 3.17 for μ -law), then in accordance with clause 3/G.121, the peak power of the speech will be suitably controlled.

NOTE – The value of +2 dB is under further study.

2.7 Determination of relative level

Figure 2 illustrates the principle of how the relative level at the input and output analogue points of a “real” codec can be determined.

When using Figure 2 to determine the relative levels of a “real” codec with non-resistive impedances at the analogue input and output ports, the following precautions must be observed:

- i) the test frequency should be 1020 (+ 2, -7) Hz, see Recommendation 0.6;
- ii) the power at points s and r is expressed as apparent power, i.e.

$$\text{Apparent power level} = 10 \log_{10} \left[\frac{(\text{Voltage at point})^2 \times 10^3}{(\text{Modulus of nominal impedance at 1020 Hz}) (1 \text{ W})} \right] \quad \text{dBm}$$

- iii) point r is terminated with the nominal design impedance of the decoder to avoid significant impedance mismatch errors.

NOTE – Precautions ii), iii) above are, of course equally applicable to the case of resistive input and output impedances and would generally be observed by conventional test procedures. Standardizing the reference frequency as in i) above is, however, essential for complex impedances because of the variation of nominal impedance with the test frequency.

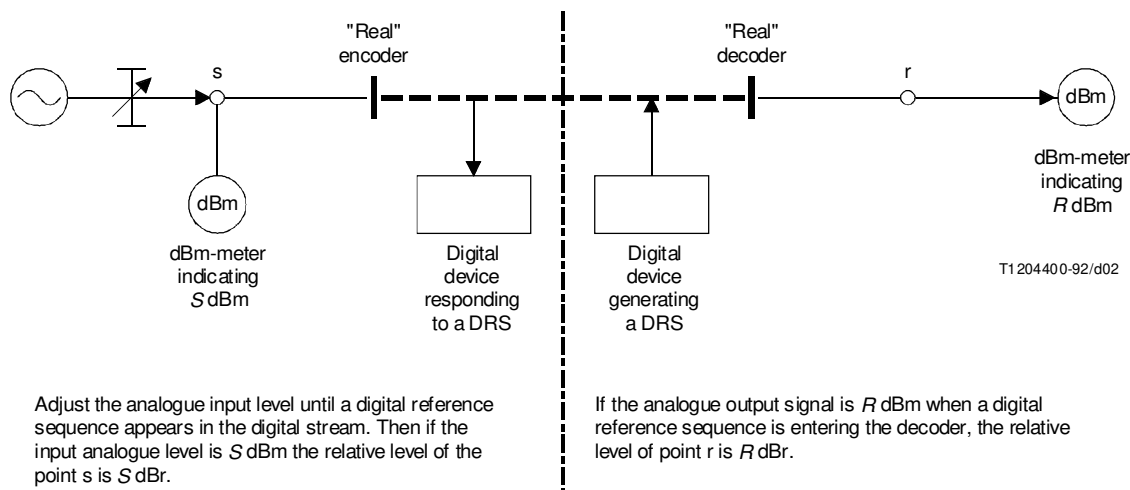

FIGURE 2/G.101

Set-up for determining the relative level at the input and output analogue points of a “real” codec using digital reference sequence

2.8 Relative level of a point in a digital link

The relative level to be associated with a point in a digital path carrying a digital bit stream generated by a coder lined-up in accordance with the principles of 2.7 above is determined by the value of the digital loss or gain between the output of the coder and the point considered. If there is no such loss or gain the relative level at the point considered is, by convention, said to be 0 dBr.

For the application of digital loss or digital gain in telephone circuits it is possible to discern the four basic cases pointed out in Figure 3. In the cases shown it is understood that the points denoted with 0 dBr (bold print) are defined by the network transmission plan. All the other relative levels in the digital path before or behind the digital pad/amplifier are derived from the aforementioned assumption.

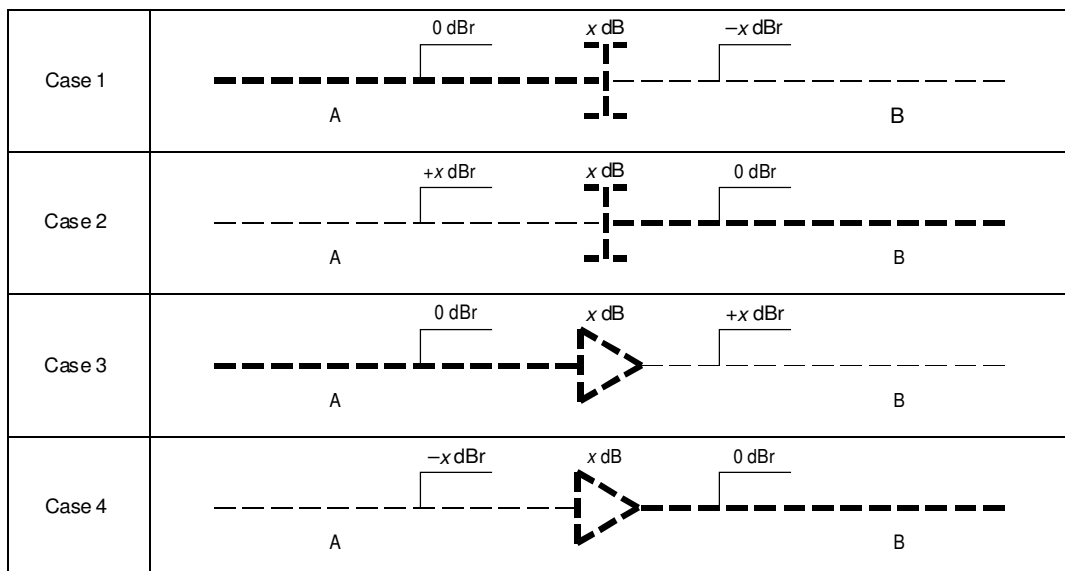

T1204410-92/d03

NOTE – In general, Case 1 and Case 4 are to be preferred.

FIGURE 3/G.101
Relative levels in a digital path

Taking the theoretical assumption that a real signal in part A of the transmission path utilizes the complete dynamic range of the PCM process according to Recommendation G.711, in part B of the transmission path:

- the dynamic range will be reduced by x dB in case 1 as well as in case 2;
- clipping effects will appear for signals with levels down to x dB below the overload limit of part A in case 3 as well as in case 4.

Therefore the occurring real signals (voice, tones, DTMF, etc.) must be observed carefully in respect to their real dynamic range in order to avoid overload. The nominal value of x of the digital gain or loss pad should be limited to a narrow range. In all four cases an additional quantizing distortion will arise.

When measuring transmission parameters (e.g. total distortion, variation of gain with input level), which usually are measured over a wide range of input levels, the input level applied to part A of the transmission path must be restricted in order to avoid improper levels at part B of the transmission path.

2.9 PCM Digital Reference Sequence (DRS)

2.9.1 Definition

A **PCM digital reference sequence** is one of the set of possible PCM code sequences that, when decoded by an ideal decoder, produces an analogue sinusoidal signal at the reference frequency (i.e. 1020 Hz) at a level of 0 dBm0.

Conversely an analogue sinusoidal signal at 0 dBm0 at the reference frequency applied to the input of an ideal coder will generate a PCM digital reference sequence.

NOTES

1 Ideal coders and decoders are assumed to show a relation between analogue and digital signals and vice-versa exactly in accordance with the appropriate tables for A-law or μ -law of Recommendation G.711. "Real" coders and decoders are assumed to be such that the performance characteristics of an encoder/decoder pair between audio frequency ports will meet the requirements of Recommendation G.712, (see Recommendation P.66).

2 The digital reference sequence above is a theoretical concept used to describe the conversion between analogue and digital signals in connection with transmission planning. For practical measurements other Digital Test Sequences (DTS) are used, e.g. as described in Recommendation P.66.

2.9.2 Use of the Digital Reference Sequence (DRS)

In studying circuits and connections in mixed analogue/digital networks, use of the digital reference sequence can be helpful. For example, Figure 4 shows the various level relationships that one obtains (conceptually) on a Type 2 international circuit, see 4.2, where one end terminates at a digital exchange and the other end at an analogue exchange. In the example of Figure 4, the analogue portion is assumed to require a loss of 0.5 dB and that provision for this loss is made by introducing a 1.0 dB pad (0.5 dB for each direction of transmission) in the receive direction at the analogue exchange. This has been deliberately chosen to illustrate the utility of the concept of a digital reference sequence.

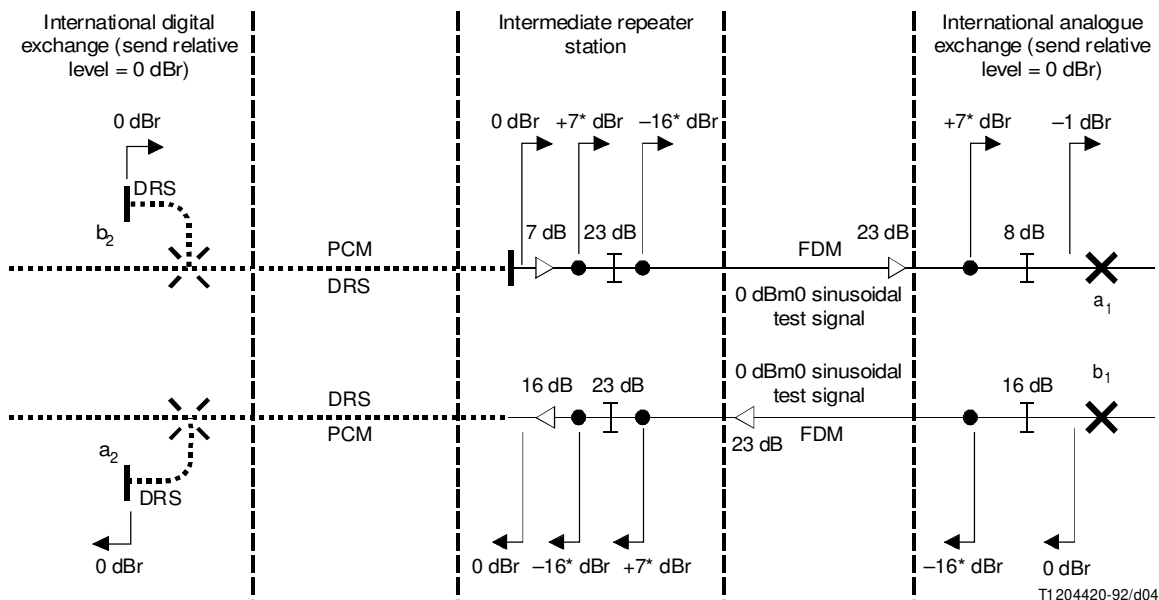

- DRS Digital reference sequence
- PCM PCM channel
- FDM FDM channel
- * one of the set of VF relative levels cited in Recommendation G.232
- x— for the purpose of illustration Multiplex VF input/output point

NOTE – For meaning of other symbols, see legend for Figure 10.

FIGURE 4/G.101
Use of digital reference sequence in the design and line-up of a type-2 international circuit

Figure 4 gives an example where all the analogue loss is introduced in the output direction at the analogue exchange. In this case the relative levels at the various codecs can be derived from either the DRS or the transmission reference point at the input of the international circuit with no ambiguity.

If, however, in Figure 4 the analogue circuit section is lined up so as to give an overall loss in the direction $b_1 - a_2$, care must be taken in the use of the DRS. In this case the 0 dBm0 sinusoidal reference signal and DRS may result in different levels at the point a_2 . Account should be taken of this effect when designing lining-up procedures for mixed analogue/digital circuits.

As a general principle, the relative levels on a mixed analogue/digital circuit should be referred to the transmission reference point at the input of the circuit. Where this is at a digital exchange, it will correspond to the “exchange test points” as defined in 1.2.1.1.2/Q.551.

2.10 The international chain of circuits: A complete international telephone connection consists of three parts, as shown in Figure 5. The division between these parts is determined by the Virtual International Connecting Points (VICPs) in the originating/terminating International Switching Centres (ISCs). These are theoretical points with specified relative levels (see 2.12 and 2.13).

The three parts of the connection are:

- Two national systems, one at each end. These may comprise one or more 4-wire national trunk circuits with 4-wire interconnection, as well as circuits with 2-wire connection up to the local exchanges and the subscriber sets with their subscriber lines.
- An international chain made up of one or more 4-wire international circuits. These are interconnected on a 4-wire basis in the international centres which provide for transit traffic and are also connected on a 4-wire basis to national systems in the international centres.

An international 4-wire circuit is delimited by its Virtual International Connecting Points in an International Switching Centre.

NOTE – The Virtual International Connecting Points may not be the same as the points at which the circuit terminates physically in the switching equipment. These latter points are known as the circuit terminals; the exact position of these terminals is decided in each case by the Administration concerned.

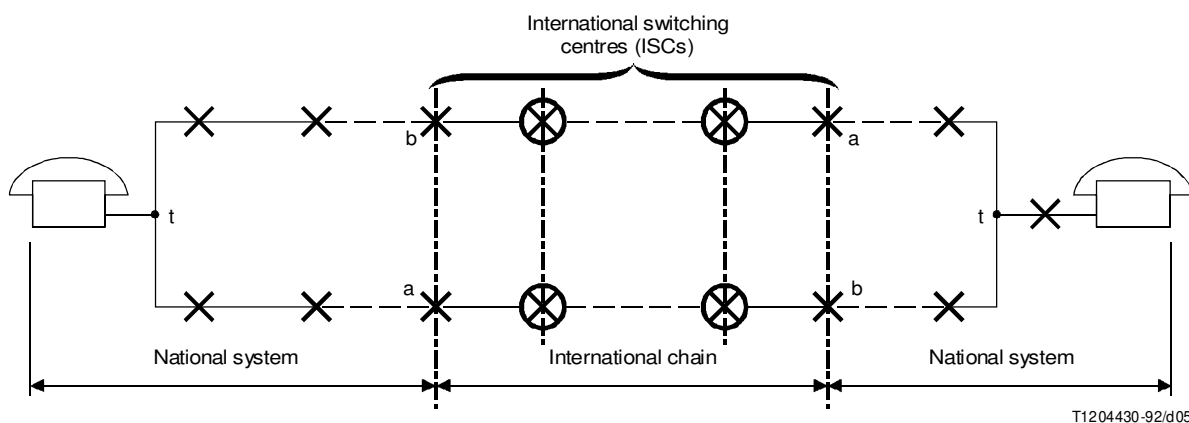
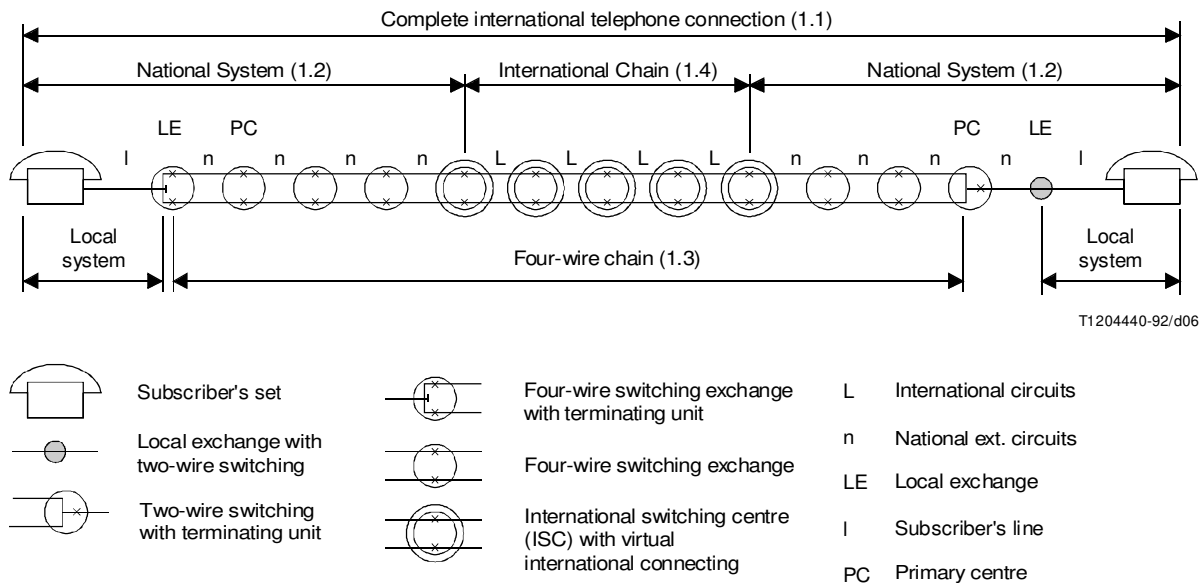

FIGURE 5/G.101

Definition of the constituent parts of an international connection

2.11 4-wire chain: The 4-wire chain (see Figure 6) denotes the whole unbroken chain of 4-wire national and international circuits in a complete telephone connection, including possible 4-wire circuits between the primary centre and the local exchange and on the subscriber line, e.g. ISDN access and 4-wire or digitally connected PBXs.



NOTE – The arrangements shown for the national systems are examples only. The numbers given in brackets refer to the subsections of section 1 (Fascicle III.1 of the *Blue Book*) in which Recommendations may be found relevant to that part of the connection. In addition, the circuits making up this chain must individually meet the requirements of subsection 1.5.

FIGURE 6/G.101

An international connection to illustrate the nomenclature adopted

2.12 virtual international connecting points (VICPs): The Virtual International Connecting Points define the boundary between the national and international parts of a connection; see Figure 5. The international connecting points are also used as reference points for transmission quantities recommended for the national and international part of a connection.

NOTE – Earlier the terms “virtual switching points” and “virtual analogue switching points” were used to define the boundary between the national and international part of a connection. These points, however, were assigned other relative levels.

2.13 Relative levels specified in the Virtual International Connecting Points

The Virtual International Connecting Points of an international 4-wire telephone circuit are by convention fixed to points in the circuit where the nominal relative levels are:

- sending: 0 dBr;
- receiving: 0 dBr for digital circuits or the very short circuits mentioned in Note 4;
 –0.5 dBr for analogue and mixed analogue digital circuits.

The nominal transmission loss of the international circuits is 0 dB for digital circuits and 0.5 dB for analogue and mixed analogue/digital circuits; see Figure 7.

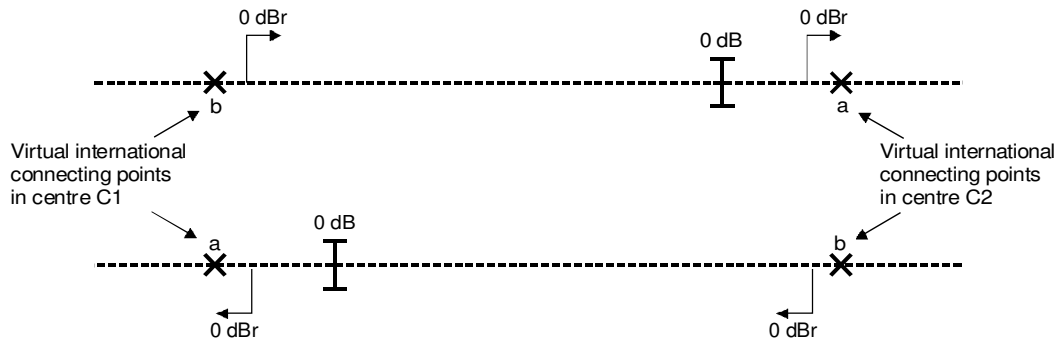

a) Definition of Virtual International Connecting Points for a digital international circuit between digital international centres

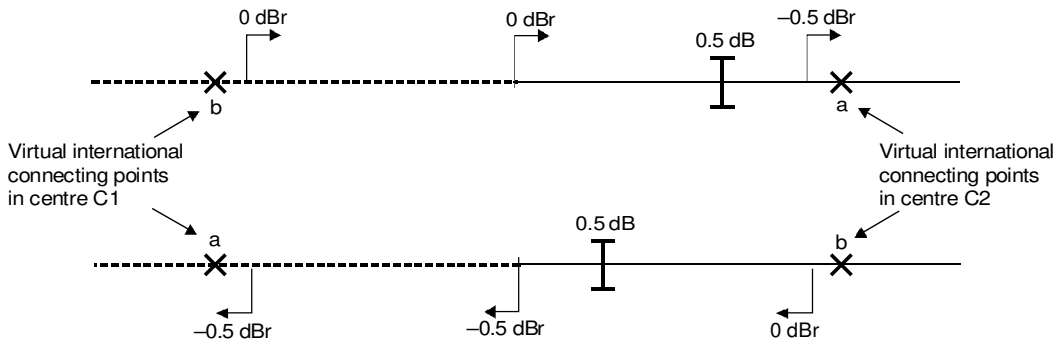

b) Definition of Virtual International Connecting Points for a mixed analogue/digital international circuit between an analogue and a digital international centre

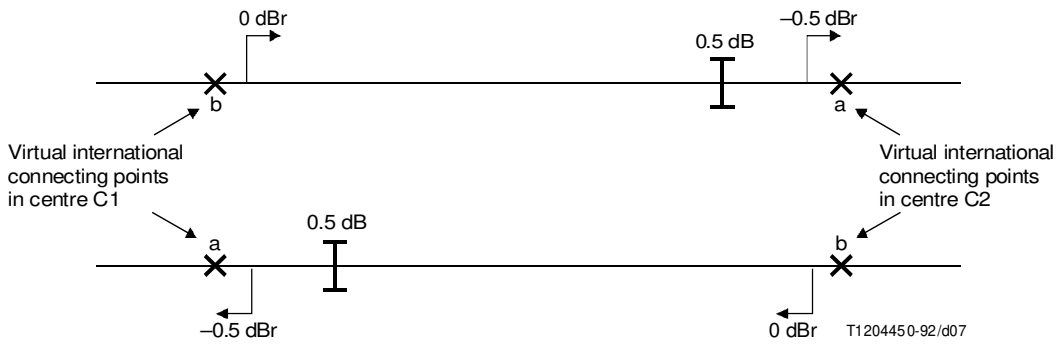

c) Definition of Virtual International Connecting Points for an analogue international circuit between analogue international centres

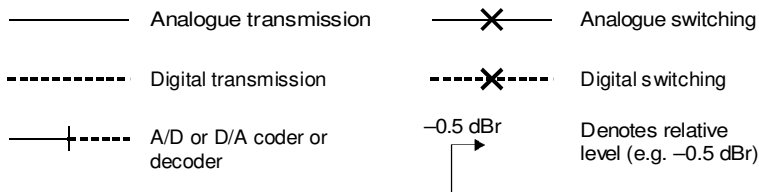

NOTE – The relative level at a point in a digital link is determined using ideal decoders as described in 2.8.

FIGURE 7/G.101
Definitions for international circuits

NOTES

1 Usually a 0.5 dB loss has to be introduced in the mixed analogue/digital circuit to satisfy the stability requirements.

2 The “virtual analogue switching points” used earlier had the relative levels:

- sending: –3.5 dBr;
- receiving: –3.5 dBr for digital circuits or the very short circuits mentioned in Note 4;
–4 dBr for analogue and mixed analogue/digital circuits.

3 The Virtual International Connecting Points in digital exchanges referred to a digital bit stream, e.g. the exchange test points. In analogue exchanges they often will not be accessible, and will differ from the switching levels nationally used in the ISC.

4 If a 4-wire analogue circuit forming part of the 4-wire chain contributes negligible delay and variation of transmission loss with time, it may be operated at zero nominal transmission loss between Virtual International Connecting Points. This relaxation refers particularly to short 4-wire tie-circuits between switching centres - e.g., circuits between two international switching centres in the same city.

2.14 circuit access point: The CCITT has defined circuit access points as being “4-wire access points so located that as much as possible of the international circuit is included between corresponding pairs of these access points at the two centres concerned” (see Recommendation M.565). These points, and their relative level (with reference to the transmission reference point), are determined in each case by the Administration concerned. They are taken as the basic reference points of known relative level to which other transmission measurements will be related. In other words, for measurement and lining-up purposes, the relative level at the appropriate circuit access point is the relative level with respect to which other levels are adjusted.

An example showing an actual arrangement is shown in Figure 8.

2.15 Measurement frequency

For all international circuits 1020 Hz is the recommended frequency for single-frequency maintenance measurements. However, by agreement between the Administrations concerned, 800 Hz may be used for such measurements on wholly analogue circuits.

NOTE – The frequency should be within 1020 (+ 2/ –7) Hz; see Recommendation O.6.

3 Number of circuits in a connection

3.1 National circuits

It seems reasonable to assume that in most countries any local exchange can be connected to the international network by means of a chain of four (or less) national circuits. Five national circuits may be needed in some countries, but it is unlikely that any country may need to use more than five circuits. Hence the CCITT has reached the conclusion that four circuits is a representative figure to assume for the great majority of international connections.

In most modern national networks, the four circuits will probably include three 4-wire circuits (usually set up on PCM or FDM transmission systems) and one 2-wire circuit often unamplified between the local exchange and the primary centre. However, more and more frequently, the circuit between the local exchange and the primary centre is 4-wire, usually set up on a PCM transmission system. The 4-wire circuits are assumed to be 4-wire switched, see 2.1/G.131.

NOTES

1 When the maximum distance between an international exchange and a subscriber who can be reached from it does not exceed about 1000 km or, exceptionally, 1500 km, the country concerned is considered as average size. In such countries, in most cases, not more than three national circuits are interconnected on a 4-wire basis between the primary centre and the international switching centre. These circuits should comply with the G.120-Series Recommendations.

2 In a large country a fourth and possibly a fifth national circuit may be included in the 4-wire chain, between the primary centre and the international switching centre, provided it has the nominal transmission loss and the characteristics recommended for international circuits used in a 4-wire chain.

3.2 International circuits

According to the International Telephone Routing Plan (see Recommendation E.171), the number of international circuits is restricted to four.

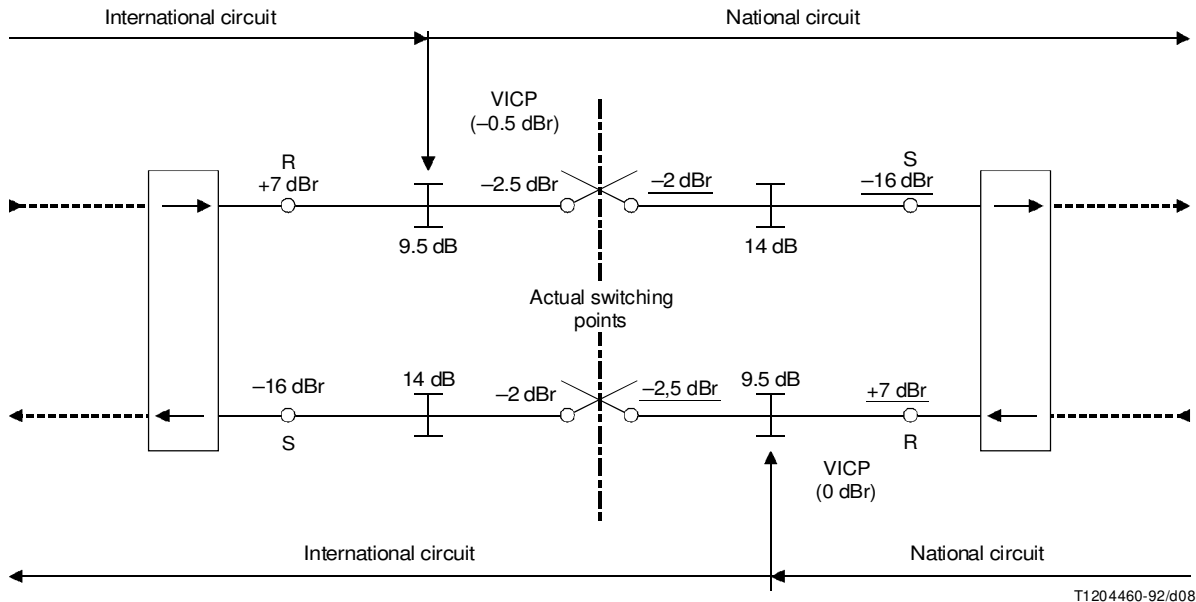

NOTES

- 1 Underlined values of relative levels refer to the national circuit. Values of relative levels not underlined refer to the international circuit. In an actual switching centre the international connecting points may not physically exist. As shown in diagram a) of Figure 7, the VICP is situated inside a 9.5 dB pad.
- 2 Each of the 9.5 and 14 dB pads include half the exchange loss.
- 3 In this example the national circuit has 0.5 dB loss, giving a 0.5 dB “level jump” in the switch at the input to the international circuit.

FIGURE 8/G.101

Example showing a simplified representation of a transit connection in an international switching centre

3.3 Hypothetical reference connections

See Recommendation G.103.

3.4 Number of circuits encountered in an international connection

Tables 1, 2 and 3 give the percentage relative and cumulative frequencies of the number of circuits encountered in an international connection calculated from a survey of about 270 million international telephone connections taken in 1973. These tables take traffic weighting into account.

4 Incorporation of unintegrated digital processes

4.1 General

The worldwide telephone network is now undergoing a transition from what is predominantly analogue operation to mixed analogue/digital operation. In the longer term, it is possible to foresee a continued transition to predominantly digital operation.

TABLE 1/G.101

**Relative frequencies of the number of circuits in the
two national extensions and the international chain
(expressed as percentages)**

Number of circuits	Originating LE-CT3	International CT3-CT3'	Terminating CT3'-LE'
1	33.8	95.1	32.9
2	38.9	4.5	39.5
3	20.2	0.3	20.4
4	6.0	–	6.1
5	1.0	–	1.0

NOTE – The relative frequencies of 6 and 7 circuits in the originating national system are 0.005% and 0.0005%, respectively. The relative frequencies of 4, 5 and 6 international circuits are 0.03%, 0.00007% and 0.00009%, respectively.

The means and modal numbers of national circuits are both equal to 2. This applies to both originating and terminating national extensions. The mean number of international circuits is 1.1 and the modal number is 1.

TABLE 2/G.101

**Relative and cumulative frequency of the total number of circuits
between local exchanges (expressed as percentages)**

Number of circuits LE to LE'	Relative frequency (%)	Cumulative frequency (%)
3	10.61	10.61
4	25.44	36.05
5	28.77	64.82
6	20.39	85.20
7	10.08	95.29
8	3.60	98.89
9	0.93	99.81
10	0.17	99.98
11	0.02	100.00

NOTE – The relative frequencies of connections with 12, 13 and 14 circuits are 0.0012%, 0.000088% and 0.0000049%, respectively. The mean value is equal to 5.1 and the modal value is equal to 5.

TABLE 3/G.101

**Relative and cumulative frequency of the number of circuits
in the 4-wire chain (expressed as percentages)**

Number of circuits in the 4-wire chain	Relative frequency (%)	Cumulative frequency (%)
1	2.65	2.65
2	14.16	16.81
3	27.49	44.30
4	26.43	70.73
5	17.28	88.01
6	8.33	96.34
7	2.83	99.18
8	0.70	99.88
9	0.11	99.99
10	0.0065	100.00

NOTE – The relative frequencies of 4-wire chains comprising 11 and 12 circuits are estimated to be 0.000475% and 0.0000322%, respectively. The mean value is equal to 3.8 and the modal value is equal to 4.

Notes to Tables 1, 2 and 3

1 The basic information, displayed in Table 1, derives from an analysis of the routing details of about 270 million telephone connections in 1973 in which 23 countries participated. LE signifies “local exchange”.

2 Table 2 is derived from Table 1 on the assumption that the three distributions of Table 1 are uncorrelated.

3 Table 3 is derived from Table 1 on the basis of the following assumptions:

- Of all the international traffic handled by primary centres, 30% originates from (or terminates at) local exchanges co-sited with the primary centre. The remaining 70% involves a trunk junction between the local exchange and the primary centre.
- In the case of routing over one national circuit, 50% of those circuits are assumed to be 4-wire and 4-wire switched at the CT3 and thus to be included in the 4-wire chain. The other 50% are assumed to be 2-wire switched at the CT3, and thus do not participate in the 4-wire chain. This is assumed to be the case for both national extensions, independently.
- Any national routing involving five to seven national circuits will incorporate a 2-wire switched trunk-junction.
- All the other routings (i.e. involving two to four national circuits) will be regarded as being with or without 2-wire switched trunk-junctions in the ratio 7:3.
- The routings in the two countries are uncorrelated.

Figure 9 is intended to demonstrate how unintegrated analogue/digital PCM processes can occur in the international network by illustrating a possible stage in the development of a national network as it progresses from all-analogue to all-digital. As indicated, subnetworks could arise in the country in which the transmission systems and the telephone exchanges are all-digital and fully integrated. Such subnetworks (referred to as “digital cells” by some) will require analogue/digital conversion processes in order to interface into the remainder of the network. Furthermore, some of the trunk-junctions (toll connecting trunks) and trunk-circuits (intertoll trunks) may be provided in some countries by 7-bit PCM systems, serving analogue exchanges. Conversely some digital exchanges may have to switch analogue circuits. Manual assistance switchboards, PBXs and subscribers’ multiplex systems using PCM digital techniques are also allowed for. Naturally, any of the circuits indicated as 7-bit PCM could be either analogue or 8-bit PCM; but one of the worst cases is illustrated.

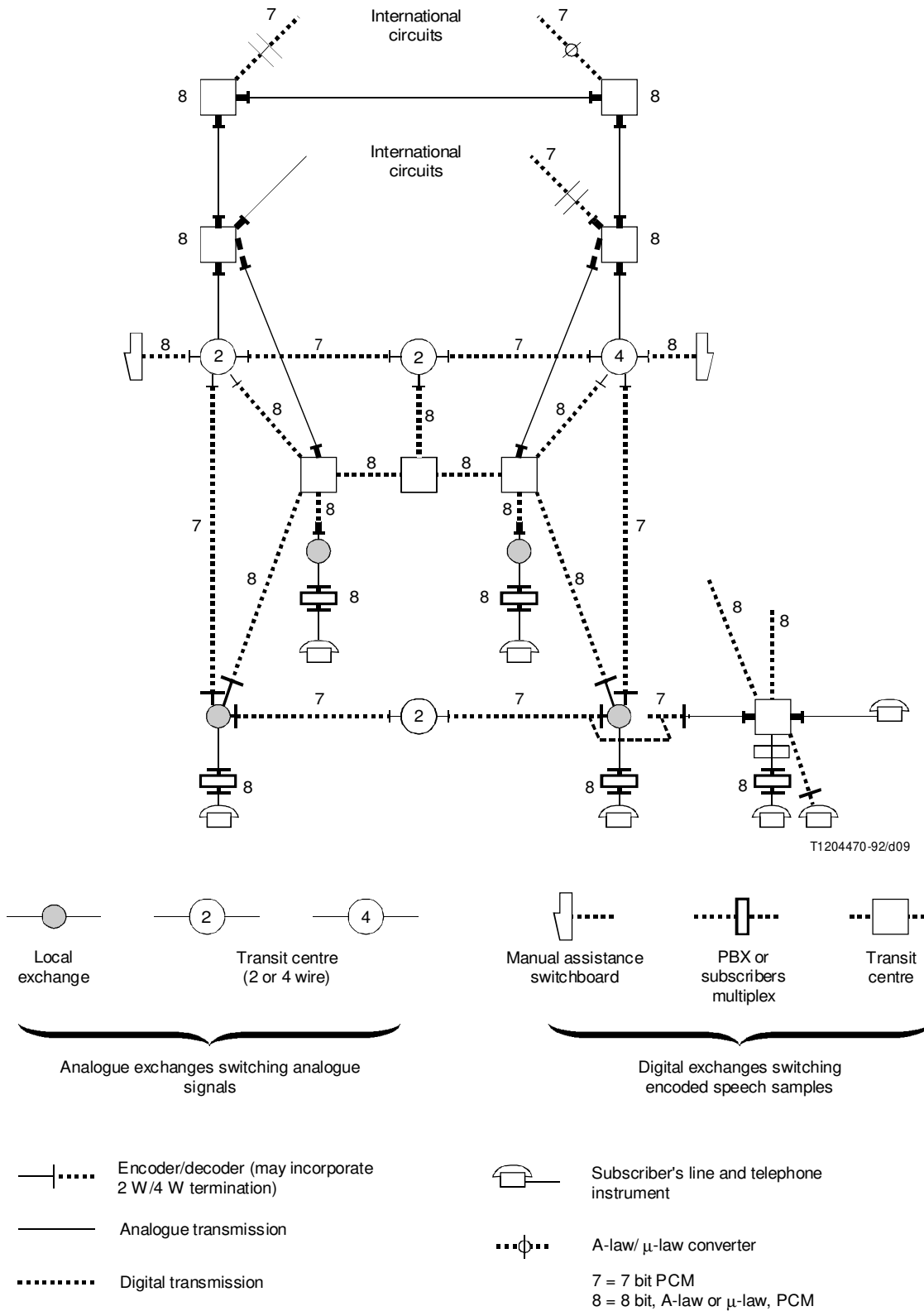

FIGURE 9/G.101

A possible intermediate stage of development in a national network

With regard to 7-bit PCM, it should be noted that such systems are not recommended by the CCITT. The only recommended analogue/digital (A/D) conversion processes for telephone services are 8-bit PCM processes (see Recommendation G.711). There are in some countries 7-bit PCM systems in operation which have been designed and installed prior to the appearance of Recommendation G.711 and, as existing systems, they should be taken into account, notwithstanding the fact that such systems are of a provisional nature as they will likely be removed from service as soon as their practical usefulness comes to an end.

In view of the foregoing, international telephone connections may for some time include one national 7-bit PCM trunk-junction (toll connecting trunk) or exceptionally two such 7-bit PCM circuits. In addition, international satellite circuits using 7-bit PCM coding may be encountered as well as A-law/ μ -law conversion processes and digital pads.

The mixed analogue/digital period is expected to last a considerable number of years. Consequently, it will be necessary to ensure that transmission performance in this period will be maintained at a satisfactory level.

4.2 Types of telephone circuits

In the mixed analogue/digital period, international circuits could, in particular, consist of the types indicated in Figure 10. In all cases, the Virtual International Connecting Points are identified (conceptually) and the relative levels at these points, specified.

Although the circuit types shown in Figure 10 are classed as international circuits, the configurations involved could also occur in national telephone networks. However, in national networks the relative levels of the circuits could be different from those indicated for international circuits.

The Type 1 circuit in Figure 10a) represents the case where digital transmission is used for the entire length of the circuit and digital switching is used at both ends. Such a circuit can generally be operated at a nominal transmission loss of 0 dB as shown because of the transmission properties exhibited by such circuits (e.g. relatively small loss variations with time).

The Type 2 circuit in Figure 10b) represents the case where the transmission path is established on a digital transmission channel in tandem with an analogue transmission channel. Digital switching is used at the digital end and analogue switching at the analogue end.

It might be possible, in some cases, to operate Type 2 circuits with a nominal loss of 0 dB in each direction of transmission. For example, where the analogue portion could be provided with the necessary gain stability and where the attenuation distortion would permit such operation.

The Type 3 circuit in Figure 10c) represents the case where the transmission path is established over a tandem arrangement consisting of digital/analogue/digital channels as shown. Digital switching is assumed at both ends.

The Type 4 circuit in Figure 10d) represents the case where the transmission path is established over a tandem arrangement consisting of analogue/digital/analogue channels as shown. Analogue switching is assumed at both ends.

The Type 5 circuit in Figure 10e) represents the case where analogue transmission is used for the entire length of the circuit and analogue switching is used at both ends.

International circuits of this type are usually operated at a loss L , where L is nominally = 0.5 dB between Virtual International Connecting Points.

NOTE – General remarks concerning the allocation of losses in the mixed analogue/digital circuits:

In circuit types 2, 3 and 4, the pads needed to control any variability in the analogue circuit sections (arising from loss variations with time or attenuation distortion) are shown in a symmetrical fashion in both directions of transmission. However, in practice, such arrangements may require non-standard levels at the boundaries between circuit sections. Administrations are advised that should they prefer to adopt an asymmetric arrangement, e.g., by putting all the loss into the receive direction at only one end of a circuit (or circuit section); then, provided that the loss is small, e.g., a total of not more than 1 dB, there is no objection on transmission plan grounds.

The small amount of asymmetry that results in the international portion of the connection will be acceptable, bearing in mind the small number of international circuits encountered in most actual connections.

As far as national circuits are concerned, Administrations may adopt any arrangements they wish provided that the requirements of 2.2/G.121, are complied with.

In some cases transmultiplexers may be used, in which case the circuits may not be available at audio-frequency at the point at which a pad symbol is used in the diagrams of Figure 10. Should the variability of the analogue portions merit additional loss, the precise way in which this loss can be inserted into the circuits is a matter for Administrations to decide bilaterally.

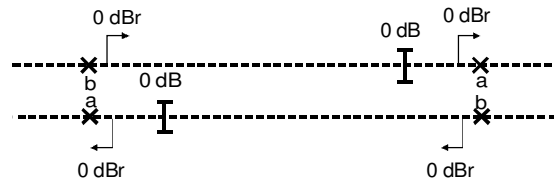

a) Type 1 circuit - All digital circuit with digital switching at both ends

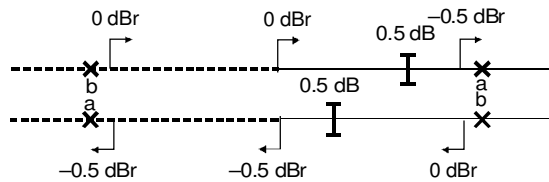

NOTE – The loss is required if the analogue circuit section introduces significant amounts of attenuation distortion or variation with time.

b) Type 2 circuit – Digital/analogue circuit with digital switching at one end and analogue switching at the other end

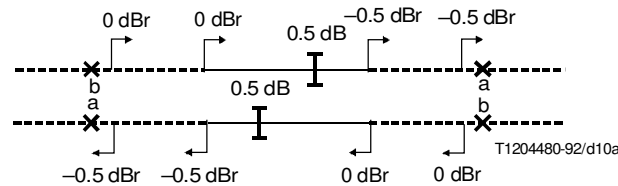

NOTE – The loss is required if the analogue circuit section introduces significant amounts of attenuation distortion or variation with time.

c) Type 3 circuit – Digital/analogue/digital circuit with digital switching at each end

FIGURE 10/G.101 (sheet 1 of 2)

Types of international circuits

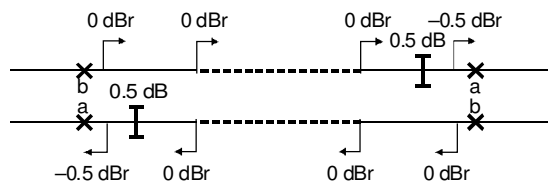

NOTE – The loss is required if the analogue circuit section introduces significant amounts of attenuation distortion or variation with time.

d) Type 4 circuit – Analogue/digital/analogue circuit with analogue switching at each end

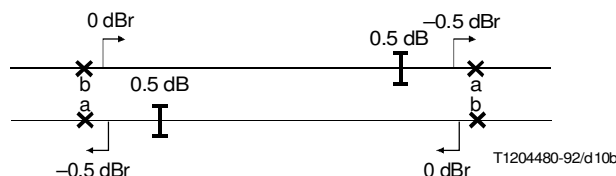

e) Type 5 circuit – All analogue circuit with analogue switching at both ends

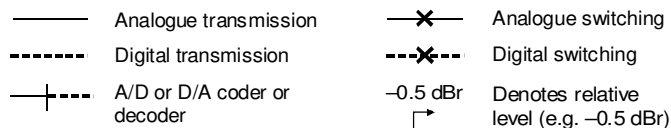

NOTES

- 1 The pad symbols in the circuits are not intended to imply that real attenuators are needed. They are a convention of transmission planning engineers.
- 2 The relative level at a point in a digital link is determined using ideal decoders as described in 2.8.

FIGURE 10/G.101 (sheet 2 of 2)
Types of international circuits

4.3 Number of unintegrated PCM digital processes

Restrictions due to transmission impairments

In the mixed analogue/digital period, it may be necessary to include a substantial number of unintegrated digital processes in international telephone connections. To ensure that the resulting transmission impairments (quantizing, attenuation and group-delay distortion) introduced by such processes do not accumulate to the point where overall transmission quality can be appreciably impaired, it is recommended that the planning rule given in clause 3/G.113 be complied with. The effect of this rule is to limit the number of unintegrated digital processes in both the national and international parts of telephone connections.

In the case of all-digital connections, transmission impairments can also accumulate due to the incorporation of digital processes (e.g. digital pads). The matter of accumulating such impairments under all-digital conditions is also dealt with in clause 3/G.113.

4.4 Transmission of analogue and digital data

In the mixed analogue/digital period, the presence in telephone connections of analogue/digital converters, encoding law converters, digital pads, or other types of digital processes, would not preclude the transmission of analogue data. However, on overall digital connections, digital type data could be adversely affected by devices such as encoding law converters and digital pads, since they involve signal recoding processes. Consequently, for the transmission of digital data, arrangements should be made to switch-out or bypass any device whose operation entails the recoding of digital data signals.

4.5 General principle

It is recognized that in the mixed analogue/digital period, there could be a considerable presence of unintegrated digital processes in the worldwide telephone network. Consequently, it is important that the incorporation of these processes should take place in such a way that when integration of functions can occur, unnecessary items of equipment would not remain in the all-digital network.

Annex A

The concepts of relative levels, dBm0, circuits and connections, and their use in transmission planning

(This annex forms an integral part of this Recommendation)

A.1 Introduction

Relative levels has been a very useful term in transmission planning for the last 30 years, and will continue to be so in the future. However, the public switched telephone networks have changed considerably in these years. Especially the introduction of digital exchanges which causes some uncertainty concerning the application of relative levels, and necessitates some changes in the traditional way of applying relative levels. Below, relative levels and associated terms have been explained and examples are shown to clarify these concepts.

A.2 Circuits and connections

The term circuit denotes the direct transmission path between two exchanges, including the associated terminating equipment in the exchanges. In transmission planning the circuit loss includes the exchange loss.

In analogue exchanges this means that "half" the exchange loss at each end of the circuit is included in the circuit loss. Therefore, the input of the circuit is in "the middle of" one exchange and the output of the circuit is "in the middle of" the other exchange. The input and output points of a circuit between analogue exchanges are not accessible points, but hypothetical points used for transmission planning.

In digital exchanges the input of the circuit will usually be a digital bit stream, e.g. at the exchange test points, and the loss in the different terminating equipment, hybrids etc. are considered to be part of the circuit.

Circuits are linked together in the exchanges, forming connections. A connection is a chain of circuits interconnected by switching points, between different points in the switched network. A complete connection is a connection between two terminal equipment connected to the switched network.

The loss of a connection is the sum of the losses of the circuits making up the connection. (Since the loss of the exchanges is included in the circuits, the switching points have no loss. There is no loss associated with the interconnecting point between two circuits, all loss is within the circuits.)

In some cases mainly in private networks, the definition of circuit is not applicable. Exchanges within a private network are normally interconnected via leased lines, specified at the interfaces of the transmission systems.

A.3 Relative levels

Relative levels are used to describe the signalling handling capacity of transmission systems, exchanges, and other types of equipment. Relative levels are also used to describe the loss between different points within a circuit, transmission system, exchange or another type of equipment.

The relative level at a point is defined as the composite gain between a hypothetical transmission reference point (0 dBr-point) and the point (or as the composite loss from the point to the transmission reference point) at the reference frequency 1020 Hz. As a rule, the transmission reference point is not accessible, but is a purely hypothetical point used to define the concept of relative level. When specifying and measuring transmission systems, exchanges, PBXs etc., the term "level reference point" is often used instead of transmission reference point.

In real life, the relative levels of different points in a circuit will be determined based on the fixed relative levels at the input and output of transmission systems or digital exchanges. The power handling capacity of these systems are defined, and the difficult task is to find the input relative level of the circuits that will ensure that the best possible loading of the transmission systems and exchanges are obtained.

The levels into the circuit will be determined by the SLR of the telephone sets used, the subscriber line and the loss in the circuits between the local exchange and the input of the circuit.

Traditionally, in transmission planning, each circuit has its own specific transmission reference point and the relative levels within a circuit are restricted only to that circuit and have no meaning outside that circuit. The loss between different points in a circuit may as a rule be found as the difference between the relative levels at the points. To find the loss between points in different circuits, it is necessary to know the transmission plan. (In networks where the circuits have no loss, e.g. digital networks, it is possible to have the same dBr-level at the output of a circuit as the dBr-level at the input of the interconnected circuit. In these special cases, the loss between different points in different circuits may be found directly as the difference in relative level. This means, however, that the transmission plan is known.)

The concept of relative levels is used for different applications, such as:

- 1) transmission planning;
- 2) setting up, lining up and maintenance of circuits;
- 3) specifying and measuring equipment, e.g. transmission systems, digital exchanges and PBXs.

These different applications all use the same basic concept of dBr, defined and described in this Recommendation. However, the different applications make use of the dBr in different ways, which in some cases may cause misunderstandings.

In transmission planning, the different points in the circuit are given dBr-levels to give the optimum performance of the circuit when the input levels and the performance of the different equipment being part of the circuit is taken into consideration. In some cases (especially for digital exchanges) this means that a point may have a different dBr-level when seen as part of the circuit, from what it has been assigned in specifications and test procedures. However, this should not cause problems if it is realized that this is merely because the different dBr-levels are used for different applications.

A.4 Digital pads and the designation of relative levels

When digital pads (or gain) are used within a circuit, the digital bit stream will have a change in the relative level as shown in Figure A.1. Here a 6 dB digital pad is introduced in a digital circuit between two digital exchanges. In this case the digital bit stream will have a level of -6 dBr on the right-hand side of the pad. If a Digital Reference Sequence (DRS) is applied at the right-hand side of the pad, it will give a level of 0 dBr. The use of the DRS should therefore be used with caution as described in 2.9.2.

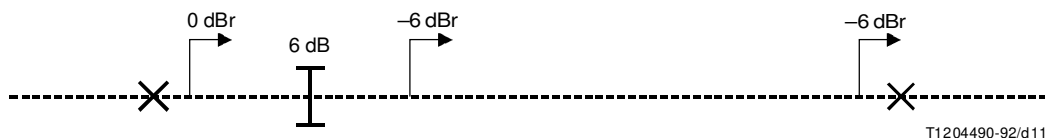

T1204490-92/d11

FIGURE A.1/G.101

A.5 Level jumps

The circuits are interconnected in the exchanges. In the analogue telephone network, where the circuits have to have loss to maintain the stability, this often means that the output of one circuit having a level of A dBr is connected to the input of another circuit having a different level B dBr. This level difference is often called a “level jump”. The “level jump” is the difference in level, i.e. B – A dB. The switching points have no loss, the “level jump” only shows that one goes from one set of dBrs particular to one circuit, to another set of dBrs particular for the other circuit. The loss will always be present within the circuits themselves. (See Example 1 below.)

A.6 Power handling capacity

In FDM transmission systems, it is the total loading resulting from the loading of all the channels in the system that may give rise to distortion because of overloading amplifiers, etc. These systems are therefore designed for a nominal mean power during the busy hour of -15 dBm0 ($32 \mu\text{W0}$) (see Recommendation G.223). (This is the mean with time and the mean of a large bunch of circuits.)

The mean power is assumed to consist of:

- 1) signalling and tones having a level of -20 dBm0 ($10 \mu\text{W0}$);
- 2) a power level of -16.6 dBm0 ($22 \mu\text{W0}$) due to:
 - speech currents, including echoes;
 - carrier leaks;
 - telegraph and phototelegraphy signals.

The contribution from carrier leaks may be as high as -26 dBm0. This gives a mean speech level of -17 dBm0. For speech, an activity factor of 0.25 is assumed. This corresponds to a mean active speech level (pauses not included) of -11 dBm0. (These relations do not account for voice-band data and facsimile transmission. This item is under study.)

PCM coders have a maximum level T_{max} of 3.14 dBm0 for A-law and 3.17 dBm0 for μ -law. This means that sinusoidal signals having r.m.s.-levels exceeding T_{max} will be clipped. This limitation applies to each channel.

In transmission planning, a main task is to ensure that the speech levels entering the transmission systems will not cause overloading of the FDM systems and that the clipping of the speech signals in PCM coders is within acceptable limits. At the same time the speech levels should be as high as possible, to give an acceptable signal-to-noise ratio.

NOTE – Active speech levels may be measured using an instrument in accordance with Recommendation P.56, method B. However, it should be noted that because the instrument has a hang-over-time of 200 ms, pauses shorter than 200 ms will not be registered, resulting in an activity factor larger than 0.25. During the measurements, precautions should be taken to avoid including voice-band data and facsimile transmission.

For measuring the activity factor, instruments having a hang-over-time less than 10 ms should be used.

A.7 Examples

Example 1

Figure A.2 shows an example of a connection consisting of two circuits. The loss of circuit 1 is 1 dB and of circuit 2 is 0.5 dB. The loss of the connection will be 1.5 dB. The loss between points A and B will be -2 dB (2 dB gain), while the difference in relative levels is -3 dB.

In exchange 2, one will have a “level jump” of $-0.5 - (-1.5) = 1$ dB.

The loss between points A and B can be found as:

$$(\text{dBr-level at A}) - (\text{dBr-level at B}) + \text{“level jump”} = -5 - (-2) + 1 = -2 \text{ dB.}$$

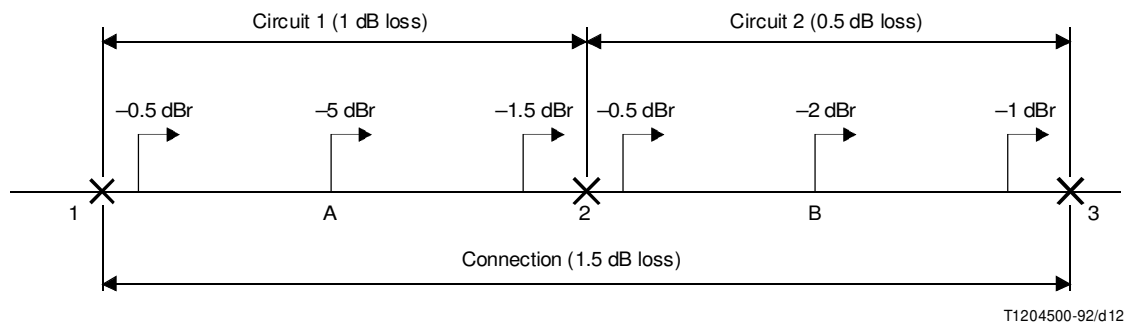

FIGURE A.2/G.101

Example 2

Figure A.3 shows an example where the circuits have no loss, and where they have the same input relative levels. In this exceptional case, the loss between the points A and B will be -3 dB, the same as the difference between the relative levels. It is possible to make a transmission plan where:

- all 4 wire circuits have 0 dB loss;
- all the circuits have the same input relative levels. In this case the whole 4-wire chain of circuits may be considered to have only one signal transmission reference point. It should be noted that this is the case only on the conditions a) and b) mentioned above. In the general case, each circuit will have its own specific transmission reference point.

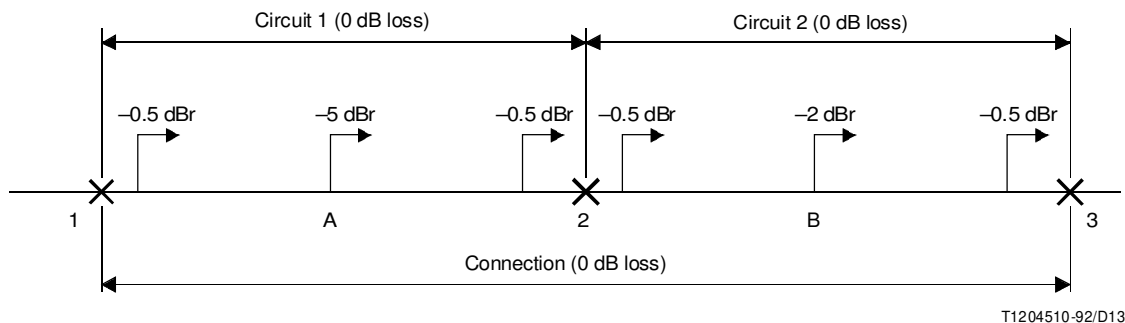

FIGURE A.3/G.101

Example 3

Figure A.4 shows an example where a circuit interconnects a digital and an analogue exchange via an analogue transmission system. For stability reasons, the circuit shall have 0.5 dB loss. The input level at the analogue exchange is 0 dBr.

The consequence of this is that on the receiving side, the digital bit stream in the digital exchange will have a level of -0.5 dBr. It should be noted that when specifying and measuring the digital exchange alone, the same digital bit stream is assigned a level of 0 dBr. This point will have another dBr-level when it is part of a circuit from what it has in specifications and equipment measurements.

NOTE – If the input relative level of the circuit had been changed to +0.5 dBr, this problem would have been avoided.

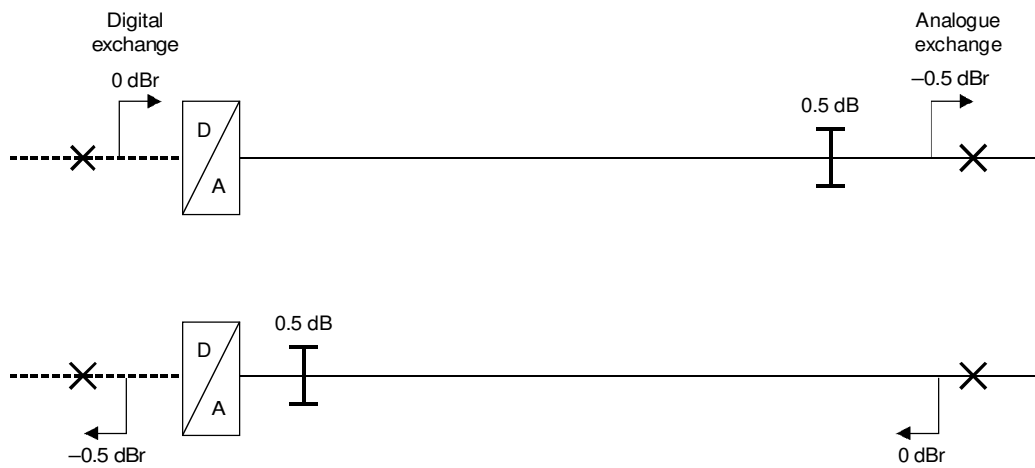

T1204520-92/d14

FIGURE A.4/G.101

Example 4

Figure A.5 shows an example where two digital exchanges are interconnected via an analogue and a digital transmission system. The relative levels specified for the transmission systems are as shown in the circles. In the transmission plan the mixed analogue/digital circuit shall have 0.5 dB loss. The relative levels of the circuit are as indicated by the arrows.

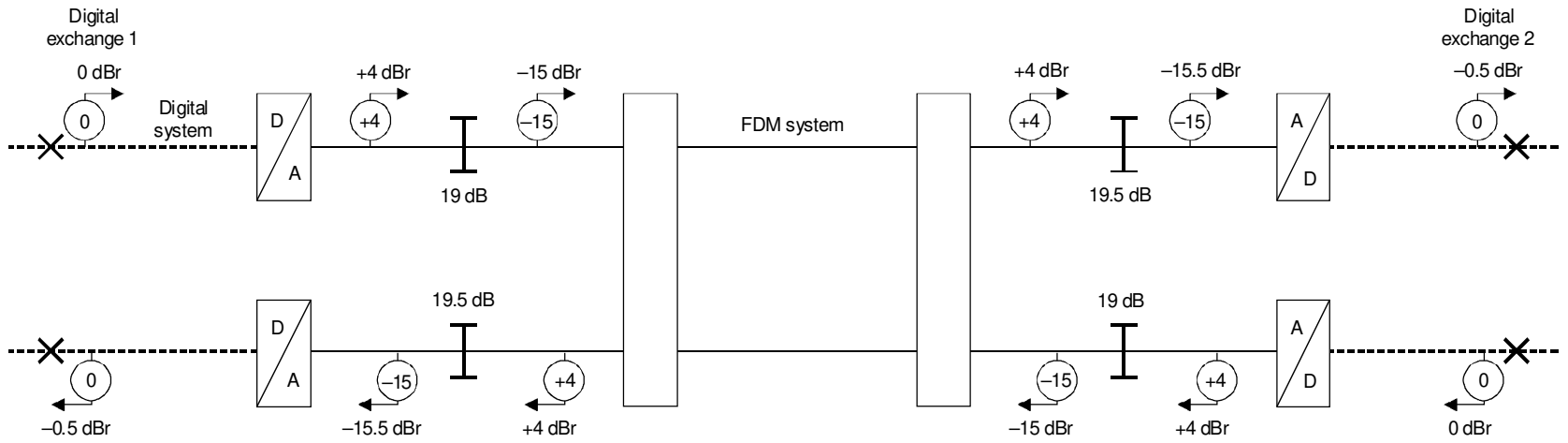

T1204530-92/d15

FIGURE A.5/G.101

References

- [1] CCITT Recommendation G.711 *Pulse Code Modulation (PCM) of Voice Frequencies*, Blue Book, Vol. III.4, Geneva, 1989.
- [2] CCITT Recommendation G.223 *Assumption for the Calculation of Noise on Hypothetical Reference Circuits for Telephony*, Blue Book, Vol. III, Geneva, 1989.
- [3] CCITT Recommendation G.371 *Carrier Systems for Submarine Cable*, Blue Book, Vol. III, Geneva, 1989.
- [4] CCITT Supplement No. 3.5 *Test frequencies on circuits routed over PCM systems*, Blue Book, Vol. IV, Geneva, 1989.