



INTERNATIONAL TELECOMMUNICATION UNION

CCITT

THE INTERNATIONAL
TELEGRAPH AND TELEPHONE
CONSULTATIVE COMMITTEE

F.423

(08/92)

MESSAGE HANDLING SERVICE

OPERATIONS AND DEFINITION OF SERVICE

**MESSAGE HANDLING SERVICES:
INTERCOMMUNICATION BETWEEN THE
INTERPERSONAL MESSAGING SERVICE
AND THE TELEFAX SERVICE**



Recommendation F.423

FOREWORD

The CCITT (the International Telegraph and Telephone Consultative Committee) is a permanent organ of the International Telecommunication Union (ITU). CCITT is responsible for studying technical, operating and tariff questions and issuing Recommendations on them with a view to standardizing telecommunications on a worldwide basis.

The Plenary Assembly of CCITT which meets every four years, establishes the topics for study and approves Recommendations prepared by its Study Groups. The approval of Recommendations by the members of CCITT between Plenary Assemblies is covered by the procedure laid down in CCITT Resolution No. 2 (Melbourne, 1988).

Recommendation F.423 was prepared by Study Group I and was approved under the Resolution No. 2 procedure on the 4th of August 1992.

CCITT NOTES

- 1) In this Recommendation, the expression "Administration" is used for conciseness to indicate both a telecommunication administration and a recognized private operating agency.
- 2) A list of abbreviations used in this Recommendation can be found in Annex B.

© ITU 1993

All rights reserved. No part of this publication may be reproduced or utilized in any form or by any means, electronic or mechanical, including photocopying and microfilm, without permission in writing from the ITU.

Recommendation F.423

MESSAGE HANDLING SERVICES: INTERCOMMUNICATION BETWEEN THE INTERPERSONAL MESSAGING SERVICE AND THE TELEFAX SERVICE

(1992)

The establishment in various countries of message handling services in association with public networks, creates the need to produce Recommendations covering the aspects of public message handling services.

TABLE OF CONTENTS

- 1 *Scope*
- 2 *Functional model*
- 3 *Service outline*
- 4 *Operational procedures*
- 5 *Quality of Service*

Annex A – Action to be taken by the PFAXAU

1 Scope

1.1 This Recommendation describes the service definition and general operational procedures for intercommunication between the public (Interpersonal Messaging) (IPM) service and the telefax services.

1.2 The intercommunication is based on store-and-forward principles and allows the users of one service to exchange messages with the users of the other service.

1.3 For facsimile users who are also registered as users of the IPM service, see Recommendation F.420.

2 Functional model

2.1 The IPM service is a messaging service which may be provided on a variety of networks and allows several forms of address, whereas the telefax services provide direct connection between user terminals in the public switched networks.

2.2 Therefore, to match the dissimilar characteristic of the services, it is necessary to provide intercommunication via a public facsimile access unit (PFAXAU). In both the IPM service to the telefax service, and the telefax service to the IPM service directions, the complete message is deposited in the PFAXAU for onward transmission.

2.3 The functional model for intercommunication described in this Recommendation is shown in Figure 1/F.423.

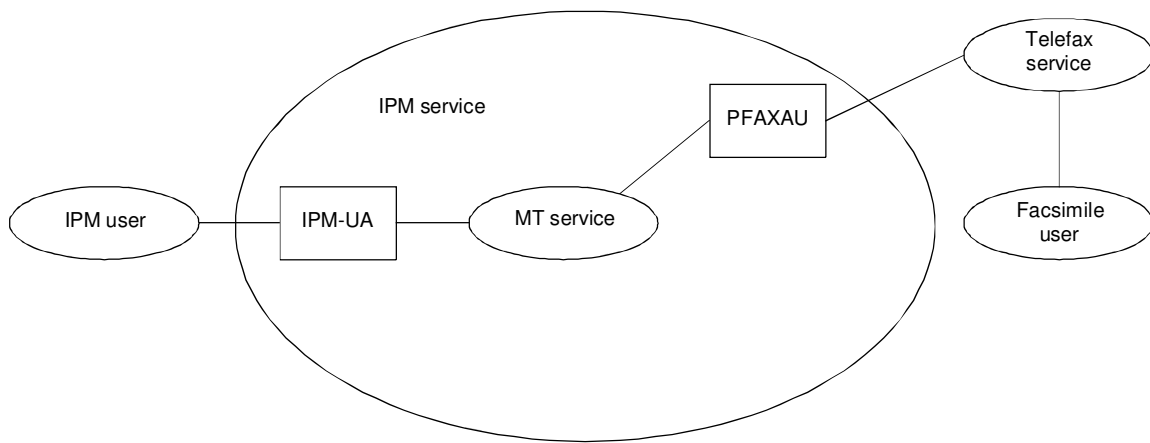

T0101630-90

UA User agent

FIGURE 1/F.423
Functional model

3 Service outline

3.1 Delivery of message to telefax service users from the IPM service and vice versa is provided by means of a PFAXAU.

3.2 The PFAXAU belongs to the message handling system (MHS) domain.

3.3 In the IPM service to telefax service direction, the IPM service PFAXAU is responsible for the message until delivery to the telefax service user terminal has been completed.

3.4 In the telefax service to IPM service direction, the IPM service PFAXAU is responsible for the delivery of the message to the IPM service user terminal, once the input is completed under normal conditions.

3.5 The PFAXAU may be located in the country of origin or country of destination as shown in Figure 2/F.423. Where two Administrations offer an IPM service, the international exchange of messages should be via the IPM service.

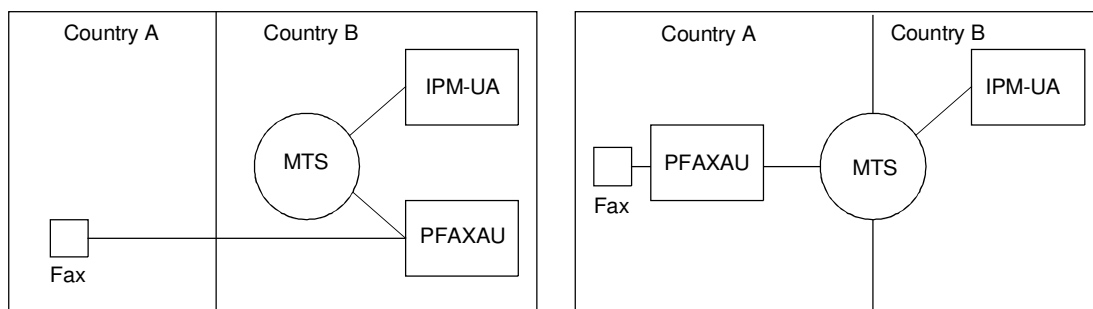

MTS Message transfer system

T0101640-90

FIGURE 2/F.423
Location of PFAXAU

3.6 Where an Administration does not provide an IPM service, then connections between the telefax service user and the PFAXAU should be via the international public switched networks.

3.7 The elements of service applicable to this intercommunication should follow Recommendation F.420.

4 Operational procedures

4.1 IPM service to telefax service direction

4.1.1 Messages from an IPM service user to a telefax user are sent as normal interpersonal (IP)-messages with the appropriate IPM elements of service, in accordance with Recommendation F.420.

4.1.2 The terminal originator/recipient (O/R) address of the telefax service user, as defined in Recommendation F.401, should be used to route a message to the telefax service user terminal.

4.1.3 When a message is received by the PFAXAU, the IP-message will be converted into the group 3 format defined for the telefax service. The delivery of IP-message to group 4 terminals is for further study.

Note – The conversion may take place in the message transfer agent (MTA) associated with the PFAXAU.

4.1.4 The PFAXAU shall be responsible for the action to be taken for IPM elements of service received in accordance with Recommendation F.420. Annex A shows the examples of the elements of service and the proposed action to be taken by the PFAXAU.

4.1.5 Call establishment to the telefax user and delivery of the facsimile message should be in accordance with normal telefax service procedures (see Recommendation T.30).

4.1.6 The IP-message sent to the telefax user terminal may be preceded by a PFAXAU identification. The content of this identification is a local matter.

4.1.7 A general layout of an IP-message delivered to a telefax user is shown in Figure 3/F.423.

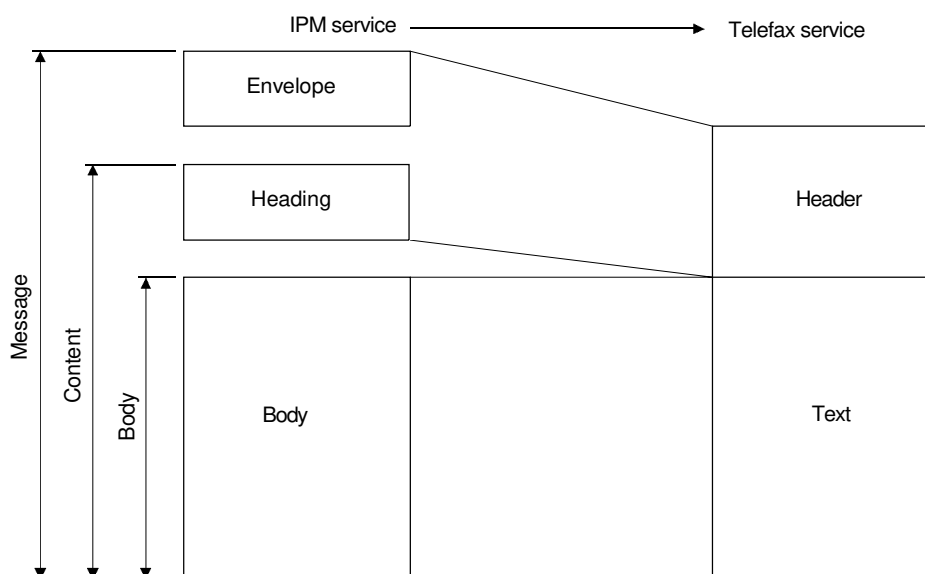

T0101650-90

FIGURE 3/F.423
IP-message to a telefax format

4.1.8 The elements of service related to the IP-message envelope and heading shall be converted into readable header. The PFAXAU shall deliver the header to a telefax user. The format and the language of this header is a local matter. The PFAXAU shall transmit the originator O/R address in a form suitable for recall.

4.1.9 Upon delivery of the message to the telefax user terminal, a delivery notification should be sent back to the originating IPM service user if requested. In the event of non-delivery of the message to the telefax user terminal, a non-delivery notification should be sent back to the IPM service user.

4.1.10 If a notification cannot be delivered to the originating IPM service user terminal, it is the responsibility of the operator of the MHS domain providing the PFAXAU to advise the originator via other suitable means.

4.2 *Telefax to IPM service direction*

4.2.1 The general selection procedures for telefax service users is for further study.

4.3 *Construction of IPM message*

For further study.

5 Quality of Service

5.1 Provision of intercommunication between the IPM service and the telefax services should maintain, as far as possible, the Quality of Service objectives of each individual service.

5.2 The PFAXAU shall be capable of supporting the basic requirements of the facsimile terminal equipment as defined in the T-Series Recommendations. The support of standardized optional user facilities is for further study.

5.3 The PFAXAU design, dimensioning and retry algorithm is a local matter.

5.4 The method of recovery when the transmission of a message from the PFAXAU to the destination telefax user terminal is interrupted, should be in accordance with store and forward facsimile service (see Recommendation F.162).

ANNEX A

(to Recommendation F.423)

Actions to be taken by the PFAXAU

Basic IPM elements of service and essential optional IPM user facilities which have to be processed by the PFAXAU in the case where a message is sent from the IPM service to the fax service direction (see Table A-1/F.423).

TABLE A-1/F.423

References Rec. F.400 Annex B	Elements of service	Action to be taken by the PFAXAU
B.5	Authorizing users indication	Display in header
B.6	Auto-forwarded indication	Ignore
B.8	Blind copy recipient indication	Display the O/R descriptor information to the blind copy recipient(s) but not disclose to either primary or copy recipients
B.9	Body part encryption indication	The PFAXAU shall send a non-delivery notification to the originator
B.12	Content type indication	National matter for content types different than P2 and P22
B.13	Conversion prohibition	If G3 fax body part, ignore; otherwise the PFAXAU generate a non-delivery notification
B.15	Converted indication	Local matter
B.18	Cross referencing indication	Display in header
B.21	Delivery notification	The PFAXAU shall send a delivery notification to the originator
B.22	Delivery time stamp indication	Local matter
B.26	DL expansion history indication	Ignore
B.29	Expiry date indication	Display in header
B.31	Forwarded IP-message indication	The PFAXAU shall display all headers
B.32	Grade of delivery selection	Local matter
B.35	Importance indication	Display in header
B.37	IP-message identification	Display in header
B.38	Language indication	Ignore
B.39	Latest delivery designation	PFAXAU should honour
B.41	Message identification	Local matter
B.45	Multi-destination delivery	Deliver the message to all recipients
B.46	Multi-part body	Messages containing not supported body parts are not delivered. Send back a non-delivery notification to the originator

Table A-1/F.423 (cont.)

References Rec. F.400 Annex B	Elements of service	Action to be taken by the PFAXAU
B.47	Non-delivery notification	The PFAXAU shall generate a delivery report
B.48	Non-receipt notification request indication	Note 1
B.52	Obsoleting indication	Local matter
B.54	Original encoded information types indication	Local matter
B.55	Originator indication	Display in header
B.56	Originator requested alternate recipient	Local matter
B.62	Primary and copy recipients indication	Display the O/R descriptor information of the recipients in the header
B.63	Probe	Local matter
B.67	Receipt notification request indication	Note 2
B.72	Reply request indication	Display in header
B.73	Replying IP-message indication	Local matter
B.80	Sensitivity indication	Local matter
B.88	Subject indication	Display in header
B.89	Submission time stamp indication	Display in header
B.90	Typed body	Local matter

Note 1 – Non-delivery notification is returned when transmission to the destination facsimile terminal is not successful.

Note 2 – Receipt notification may be returned according to the request in the subject message when message transmission to the destination facsimile terminal is completed. In this context, the use of receipt notification has an equivalent meaning to positive delivery notification for PFAXAU as described in § 4.1.9 of this Recommendation.

ANNEX B

(to Recommendation F.423)

Alphabetical list of abbreviations used in this Recommendation

IP	Interpersonal
IPM	Interpersonal messaging
MHS	Message handling system
MT	Message transfer
MTA	Message transfer agent
MTS	Message transfer system
O/R	Originator/recipient
PFAXAU	Public facsimile access unit