



INTERNATIONAL TELECOMMUNICATION UNION

CCITT

THE INTERNATIONAL
TELEGRAPH AND TELEPHONE
CONSULTATIVE COMMITTEE

E.170

(10/92)

**TELEPHONE NETWORK AND ISDN
OPERATION, NUMBERING, ROUTING
AND MOBILE SERVICE**

TRAFFIC ROUTING



Recommendation E.170

FOREWORD

The CCITT (the International Telegraph and Telephone Consultative Committee) is a permanent organ of the International Telecommunication Union (ITU). CCITT is responsible for studying technical, operating and tariff questions and issuing Recommendations on them with a view to standardizing telecommunications on a worldwide basis.

The Plenary Assembly of CCITT which meets every four years, establishes the topics for study and approves Recommendations prepared by its Study Groups. The approval of Recommendations by the members of CCITT between Plenary Assemblies is covered by the procedure laid down in CCITT Resolution No. 2 (Melbourne, 1988).

Recommendation E.170 was revised by Study Group II and was approved under the Resolution No. 2 procedure on the 30th of October 1992.

CCITT NOTES

- 1) In this Recommendation, the expression "Administration" is used for conciseness to indicate both a telecommunication administration and a recognized private operating agency.
- 2) A list of abbreviations used in this Recommendation can be found in Annex A.

© ITU 1993

All rights reserved. No part of this publication may be reproduced or utilized in any form or by any means, electronic or mechanical, including photocopying and microfilm, without permission in writing from the ITU.

Recommendation E.170

TRAFFIC ROUTING

(revised 1992)

1 Introduction

1.1 Objective of traffic routing

The objective of routing is to establish a successful connection between any two exchanges in the network. The function of traffic routing is the selection of a particular circuit group, for a given call attempt or traffic stream, at an exchange in the network. Thus, the selection of individual circuits within a circuit group is not considered in this Recommendation. The choice of a circuit group may be affected by information on the availability of downstream elements of the network.

1.2 Scope of Recommendation

This Recommendation takes account of the range of new traffic routing and control techniques which are provided by stored program controlled (SPC) exchanges and common channel signalling systems.

Additional routing information is contained in Recommendation E.171 (International telephone routing plan) and Recommendation E.172 (Call routing in the ISDN era).

Failure or overload conditions may require temporary changes to routing patterns or algorithms. This is considered to be a network management action and is described in the E.400-Series Recommendations.

1.3 Network topology

1.3.1 Network elements

A network comprises a number of nodes (switching centres) interconnected by circuit groups (engineering routes). There may be several direct circuit groups between a pair of nodes and these may be unidirectional or bothway. Figure 1/E.170 illustrates a number of possible situations.

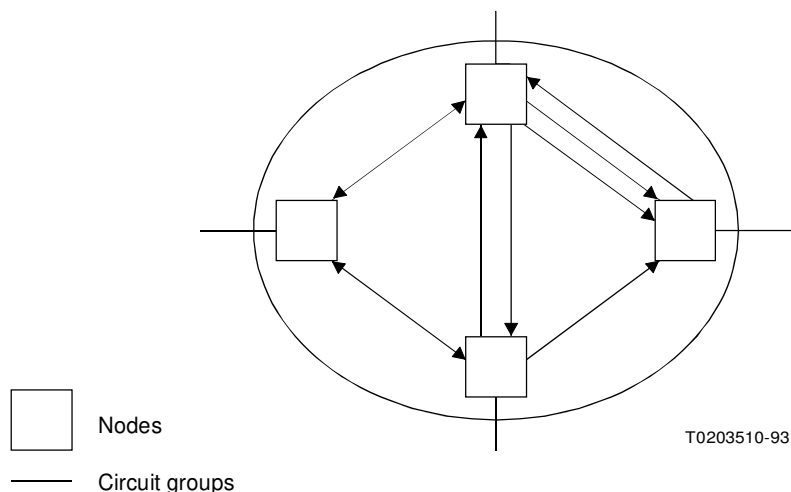

FIGURE 1/E.170

A direct route consists of one or more circuit groups connecting adjacent nodes. An indirect route is a series of circuit groups connecting two nodes providing an end-to-end connection via other nodes.

1.3.2 Network architecture

Within national networks it is often appropriate to adopt a hierarchy of switching units (e.g. local, area, trunk, regional trunk, international) with each level of the hierarchy performing different functions. For the international network, there is no recommended hierarchy for international switching centres (ISCs) with Administrations being free to determine the most suitable utilization of their individual ISCs. (Recommendation E.171 refers.)

2 Logic of routing

2.1 Routing structure

It is important to note that the concept of hierarchical routing need not be directly related to the concept of a hierarchy of switching centres (as described above).

A routing structure is hierarchical if, for all streams, all calls offered to a given route, at a specific node, overflow to the same set of routes irrespective of the routes already tested. The routes in the set will always be tested in the same sequence although some routes may not be available for certain call types. The last choice route is final in the sense that no traffic streams using this route may overflow further.

A routing structure is non-hierarchical if it violates the above-mentioned definition (e.g. mutual overflow between circuit groups originating at the same exchange).

An example of hierarchical routing in a non-hierarchical network of exchanges is illustrated in Figure 2/E.170.

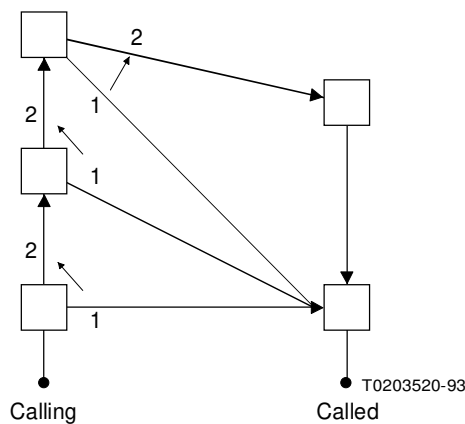

Note – All nodes are of equal status.

FIGURE 2/E.170

2.2 Routing scheme

The routing scheme defines how a set of routes is made available for calls between a pair of nodes.

Fixed: The set of routes in the routing pattern is always the same.

Dynamic: The set of routes in the routing pattern varies.

2.2.1 Fixed routing scheme

Routing patterns in the networks may be fixed, in that changes to the route choices for a given type of call attempt require manual intervention. Changes then represent a “permanent change” to the routing scheme (e.g. the introduction of new routes require a change to a fixed routing scheme).

2.2.2 Dynamic routing schemes

Routing schemes may also incorporate frequent automatic variations. Such changes may be time dependent, state dependent and/or event dependent.

The updating of routing patterns may take place periodically or aperiodically, predetermined, depending on the state of the network or depending on whether calls succeed or fail.

2.2.2.1 Time-dependent routing

Routing patterns will be altered at fixed times during the day (or week) to allow changing traffic demands to be provided for. It is important to note that these changes are pre-planned and will be implemented consistently over a long time period.

2.2.2.2 State-dependent routing

Routing patterns will vary automatically according to the state of the network. Such routing schemes are said to be adaptive.

In order to support this type of routing scheme, it is necessary to collect information about the status of the network. For example, each exchange may compile records of successful calls or outgoing trunk group occupancies. This information may be distributed through the network to other exchanges or passed to a centralized database.

Based on this network status information, routing decisions will be made either in each exchange or at a central processor serving all exchanges. See Figure 3/E.170.

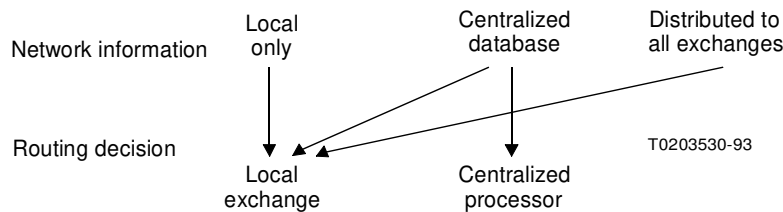

FIGURE 3/E.170

2.2.2.3 Event-dependent routing

Routing patterns will be updated locally on the basis of whether calls succeed or fail on a given choice. Each exchange will have a list of choices and the updating will favour those choices which succeed and discourage those which suffer congestion.

2.3 Route selection

Route selection is the action to actually select a definite route for a specific call.

Sequential: The routes in a set are always tested in sequence and the first available route is chosen.

Non-sequential: The routes in a set are tested in no specific order.

The decision to select a route can be based on the state of the outgoing circuit group or the states of the series of circuit groups in the route. In either case, it can also be based on the incoming path of entry, class of service, or type of call to be routed. One example of the above is selective trunk reservation.

3 Call control procedures

Call control procedures define the entire set of interactive signals necessary to establish, maintain and release a connection between exchanges. Described below are two main types of call control procedures:

3.1 Progressive call control

Progressive call control uses link-by-link signalling to pass supervisory controls sequentially from one exchange to the next. This type of call control can be either irreversible or reversible. In the irreversible case, call control is always passed downstream towards the destination exchange. Call control is reversible when it can be passed backwards (maximum one node), towards the originating exchange, using automatic rerouting or crankback possibilities.

3.2 Originating call control

Originating call control requires that the originating exchange maintain control of the call set-up until a connection between the originating and terminating exchanges has been completed.

4 Applications

4.1 Automatic alternative routing

A particular type of progressive (irreversible) routing is automatic alternative routing (AAR). When an exchange has the option of using more than one route to the next exchange, an alternative routing scheme can be employed.

Two main types are available:

- when there is a choice of direct circuit groups between the two exchanges;
- when there is a choice of direct and indirect routes between the two exchanges.

Alternative routing takes place when all appropriate circuits in a group are busy. Several circuit groups may be tested sequentially. The testing order will be fixed or time-dependent.

4.2 Automatic rerouting (crankback)

Automatic rerouting (ARR) is a routing facility enabling connection of call attempts encountering congestion during the initial call setup phase.

Thus, if a signal indicating congestion is received from Exchange B (see Figure 4/E.170), subsequent to the seizure of an outgoing trunk from Exchange A, the call can be rerouted at A.

It is, however, possible to improve the situation through the use of different signals indicating congestion, S1 and S2:

- S1 indicates that congestion has occurred on outgoing trunks from Exchange B;
- S2 indicates that congestion has occurred further downstream, e.g. on outgoing trunks from D.

The action to be taken at Exchange A upon receiving S1 or S2 may be to either block the call or reroute it. The choice of action at Exchange A is subject to bilateral agreement.

In the example of Figure 4/E.170, a call from A to D is routed via C because the circuit group B-D is congested (S1-indicator) and a call from A to F is routed via E because the circuit group D-F is congested (S2-indicator)

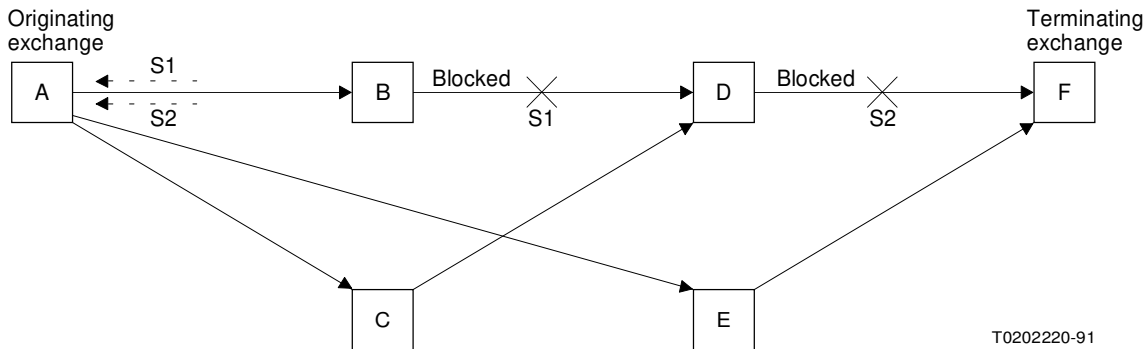

Note – Blocking from B to D activates signal S1 to A. Blocking from D to F activates signal S2 to A.

FIGURE 4/E.170

Administrations may wish to consider the increase in signalling load and the number of call set-up operations resulting from the use of these signals. If the increase is unacceptable, administrations may restrict the number of recoutings or limit the signalling capability to fewer exchanges.

Finally, care must be taken to avoid circular routings which return the call to the point at which blocking previously occurred during the call set-up.

4.3 Load sharing

All routing schemes result in the sharing of traffic load between network elements. Routing schemes can however be developed to ensure that call attempts are offered to route choices according to a preplanned distribution.

Figure 5/E.170 illustrates this application of load sharing which can be made available as a software function of SPC exchanges. The system works by distributing the call attempts to a particular destination in a fixed ratio between the specified outgoing routing patterns.

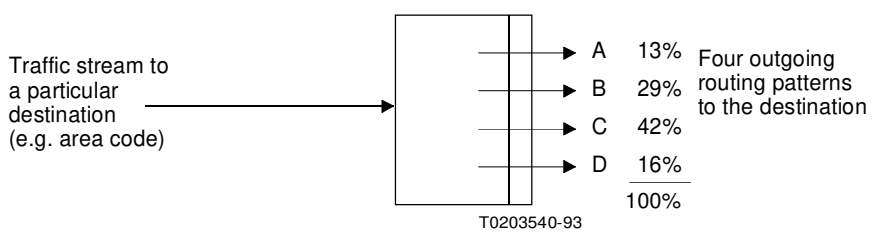

Note – Each outgoing routing pattern (A, B, C, D) may include alternative routing options.

FIGURE 5/E.170

4.4 *Dynamic routing*

4.4.1 *Example of state-dependent routing*

A centralized routing processor is employed to select optimum routing patterns on the basis of the actual occupancy levels of the circuit groups and exchanges in the network which are monitored on a periodical basis (e.g. 10 s), see Figure 6/E.170. In addition, qualitative traffic parameters may also be taken into consideration in the determination of the optimal routing pattern.

This routing technique inherently incorporates fundamental principles of network management in determining routing patterns. These include:

- avoiding occupied circuit groups;
- not using overloaded exchanges for transit;
- in overload circumstances, restriction of routing direct connections.

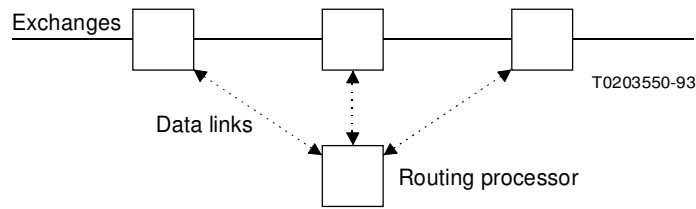
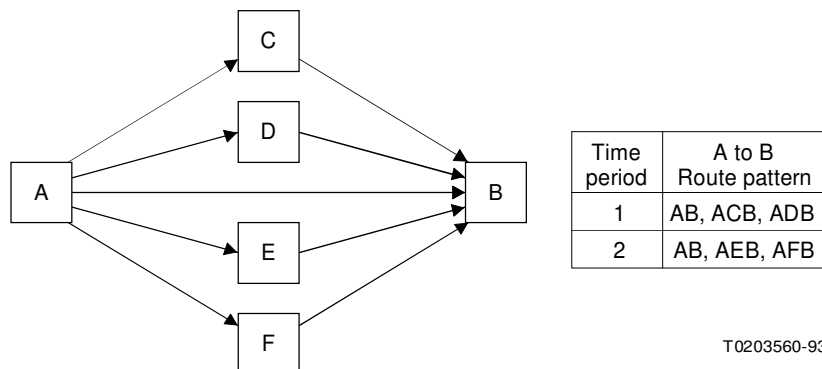

FIGURE 6/E.170

4.4.2 *Example of time-dependent routing*

For each originating and terminating exchange pair, a particular route pattern is planned depending on the time of day and day of week, see Figure 7/E.170. A weekday, for example, can be divided into different time periods, with each time period resulting in different route patterns being defined to route traffic streams between the same pair of exchanges.

This type of routing takes advantage of idle circuit capacity in other possible routes between the originating and terminating exchanges which may exist due to non-coincident busy periods. Crankback may be utilized to identify downstream blocking on the second link of each two-link alternative path.



T0203560-93

FIGURE 7/E.170

4.4.3 Example of event-dependent routing

In a fully connected network, calls between each originating and terminating exchange pair try the direct route with a two-link alternative path selected dynamically. Whilst calls are successfully routed on a two-link path, that alternative will be retained. Otherwise a new two-link alternative path will be selected. This updating, for example, could be at random or weighted by the success of previous calls.

This type of routing scheme routes traffic away from congested links by retaining routing choices where calls are successful. It is simple, adapts quickly to changing traffic patterns and requires only local information.

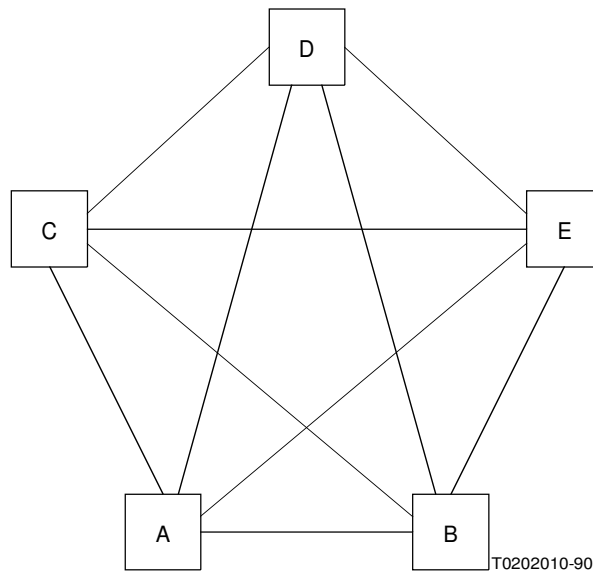

A to B route pattern		
Choice	Current	After call failure
1	AB	AB
2	AEB	ACB

5 History

First published in 1988 (*Blue Book*).

Revised in 1992.

ANNEX A

(to Recommendation E.170)

**Alphabetical list of abbreviations
used in this Recommendation**

AAR	Automatic alternative routing
ARR	Automatic rerouting
ISC	International switching centre
SPC	Stored program controlled